

Northumbria Research Link

Citation: Ajao, Kajogbola R., Ibitoye, Segun E., Adesiji, Adedire D. and Akinlabi, Esther (2022) Design and Construction of a Low-Cost-High-Accessibility 3D Printing Machine for Producing Plastic Components. Journal of Composites Science, 6 (9). p. 265. ISSN 2504-477X

Published by: MDPI

URL: <http://dx.doi.org/10.3390/jcs6090265> <<http://dx.doi.org/10.3390/jcs6090265>>

This version was downloaded from Northumbria Research Link:
<https://nrl.northumbria.ac.uk/id/eprint/50333/>

Northumbria University has developed Northumbria Research Link (NRL) to enable users to access the University's research output. Copyright © and moral rights for items on NRL are retained by the individual author(s) and/or other copyright owners. Single copies of full items can be reproduced, displayed or performed, and given to third parties in any format or medium for personal research or study, educational, or not-for-profit purposes without prior permission or charge, provided the authors, title and full bibliographic details are given, as well as a hyperlink and/or URL to the original metadata page. The content must not be changed in any way. Full items must not be sold commercially in any format or medium without formal permission of the copyright holder. The full policy is available online: <http://nrl.northumbria.ac.uk/policies.html>

This document may differ from the final, published version of the research and has been made available online in accordance with publisher policies. To read and/or cite from the published version of the research, please visit the publisher's website (a subscription may be required.)



**Northumbria
University**
NEWCASTLE



UniversityLibrary



Article

Design and Construction of a Low-Cost-High-Accessibility 3D Printing Machine for Producing Plastic Components

Kajogbola R. Ajao¹, Segun E. Ibitoye^{1,2,*} , Adedire D. Adesiji¹ and Esther T. Akinlabi³

¹ Department of Mechanical Engineering, Faculty of Engineering and Technology, University of Ilorin, PMB 1515, Ilorin 240222, Nigeria

² Department of Mechanical Engineering Science, Faculty of Engineering and the Built Environment, University of Johannesburg, P.O. Box 524, Auckland Park 2006, South Africa

³ Department of Mechanical and Construction Engineering, Faculty of Engineering and Environment, Northumbria University, Newcastle NE1 8ST, UK

* Correspondence: ibitoye.s@unilorin.edu.ng

Abstract: The additive manufacturing process creates objects directly by stacking layers of material on each other until the required product is obtained. The application of additive manufacturing technology for teaching and research purposes is still limited and unpopular in developing countries, due to costs and lack of accessibility. In this study, an extruding-based 3D printing additive manufacturing technology was employed to design and construct a low-cost-high-accessibility 3D printing machine to manufacture plastic objects. The machine was designed using SolidWorks 2020 version with a $10 \times 10 \times 10 \text{ cm}^3$ build volume. The fabrication was carried out using locally available materials, such as PVC pipes for the frame, plywood for the bed, and Zinc Oxide plaster for the bed surface. Repetier firmware was the operating environment for devices running on the computer operating system. Cura was used as the slicing software. The fabricated machine was tested, and the printer produced 3D components with desired structural dimensions. The fabricated 3D printer was used to manufacture some plastic objects using PLA filament. The recommended distance between the nozzle tip and the bed is 0.1 mm. The constructed 3D printer is affordable and accessible, especially in developing nations where 3D printing applications are limited and unpopular.

Keywords: 3D printer; additive manufacturing; slicing software; firmware



Citation: Ajao, K.R.; Ibitoye, S.E.; Adesiji, A.D.; Akinlabi, E.T. Design and Construction of a Low-Cost-High-Accessibility 3D Printing Machine for Producing Plastic Components. *J. Compos. Sci.* **2022**, *6*, 265. <https://doi.org/10.3390/jcs6090265>

Academic Editors: Yuan Chen and Francesco Tornabene

Received: 29 June 2022

Accepted: 1 August 2022

Published: 9 September 2022

Publisher's Note: MDPI stays neutral with regard to jurisdictional claims in published maps and institutional affiliations.



Copyright: © 2022 by the authors. Licensee MDPI, Basel, Switzerland. This article is an open access article distributed under the terms and conditions of the Creative Commons Attribution (CC BY) license (<https://creativecommons.org/licenses/by/4.0/>).

1. Introduction

For decades, machines and parts have been constructed using traditional (subtractive) methods, such as welding, folding, soldering, machining, etc. The conventional machining methods include milling, drilling, grilling, and turning [1,2]. The methods fabricate products and parts by removing material from a block of material to achieve the required geometry. The machining methods have helped humankind to create different things [3]. However, several constraints have limited its performance and efficiency—it is challenging to produce intricate parts, fixtures, time and energy-consuming, low precision and accuracy, expensive, and waste materials. The introduction of non-conventional machinings, such as electric discharge and chemical machining and the utilization of computer technology, helps to minimize these drawbacks [1,4].

In contrast, additive manufacturing is constructing an object by making a successive layer of materials to form the object [5–8]. An example of additive manufacturing is a three-dimensional (3D) printing process - a process of fabricating 3D objects from a numerical file [1,9]. Three-dimensional printing consists of computer-assisted design, added material, and the machine [10]. The printing process starts by making a digital object design using computer-aided design (CAD) software or capturing the object with a 3D scanner. Popular software choices include SolidWorks, AutoCAD, Inventor, etc. [11–13]. The CAD design defines the geometry of the object [1,14], and the CAD design quality significantly affects

the printer's production and precision [3]. CAD designs are prepared for printing by slicing the design into a series of horizontal layers using slicing software while uploading into the 3D printer. The slicing software also generates a G-code for each sliced layer and creates a specific tool-path instruction for the extruder head that deposits the material layer by layer [8,15,16]. The American Society for additive manufacturing established standards that categorize the additive manufacturing processes into seven bases: material extrusion, directed energy deposition, vat photopolymerization, binder jetting, sheet lamination, material jetting, and powder bed fusion [17].

Three-dimensional printers use different technology to fabricate the final product layer by layer. Some technology melts the material, while some employ a high-powered ultraviolet laser to cure photo-reactive resin, creating the layer to manufacture the final products [1,17]. Examples of this technology include fused deposition modeling, stereolithography, and selective laser sintering [1,3,10]. The 3D printing technology allows the fabrication of complex and intricate objects without assembly. It saves time, labor, cost, and energy. Three-dimensional printing was initially used for prototyping, but recently it has found more applications in manufacturing processes [14]. Applications of 3D printing can be found in medicine, entertainment, maquettes, industrial and biomedical engineering, architectural model, aerospace, defense, automotive, etc. [1,18].

Several research efforts on manufacturing 3D printers and printing 3D objects have been reported in the literature, including studies on the mechanics and materials characteristics [19–23]. Raja et al. [24] fabricated a calcium-deficient hydroxyapatite bone scaffold at low temperature. The 3D printer conditions were optimized, and outstanding mechanical characteristics were achieved at 70% porosity without sintering after the 3D printing. The essential factor required to complete low-temperature fabrication of calcium phosphate via 3D printing were enumerated in the report. A similar study was conducted by Xiao et al. [25]. They fabricated porous polycaprolactone scaffolds through 3D printing at low temperatures. Polymer printing inks were prepared, and their rheological characteristics printing inks were assessed. The performance of the printing was evaluated. Different porous polycaprolactone scaffolds were constructed using printing inks at different feed ratios. Analyses of the results revealed that the printing ink formulation is significantly affected by the performance of the 3D printer.

A surface made of a flexible antiadhesive polymer was constructed using a 3D printer [15]. A fused deposition model type was used to make the molds with microgrid arrangements. The shape of the arrangement was controlled by moving the mold (where the filament is printed) circularly. Twelve different antiadhesive surfaces were fabricated by changing the direction of the mold. The adhesive characterization showed that mold with microgrid Y with an internal angle and resolution of 60° and 800 μm, respectively, displayed the best adhesive characteristics. A reduction in adhesive forces of 92.6% and 99.5% was recorded when the Kapton tape was immediately attached and detached, and when the Kapton tape was separated after eighteen days, respectively.

Sevvel et al. [26] designed and constructed a desktop 3D printer by adopting the Fused Deposition Modeling (FDM) principle. The major component of the machine includes an x-y component, timer, extruder, Arduino board, extruder nozzle, extruder head, and fin-fitted extruder nozzle. The display system could show the timer, extruder temperature, and axis position. It functions by utilizing three software: Cura, SolidWorks, and Pronterface. It was reported that the machine performed satisfactorily.

A comprehensive review composed of the basics, types, techniques, advantages and disadvantages of 3D printing can be found in Bhusnure et al. [3]. Also, a detailed report on the comparison of different kinds of 3D printing technologies can be found in Jasveer and Jianbin [2], while a review on the prospects in 3D printing for nanocomposite materials is presented in Patel et al. [27].

Low-cost 3D printers range from \$100 to \$1000, whereas budget printers cost less than \$300, and advanced hobbyist printers' prices are between \$300 and \$1000 [28]. On the other side of the spectrum, professional printers cost between \$1000 and \$5000, and

industrial printers cost over \$5000. The high-end printers offer more speed, print quality, and reliability. The use of low-cost desktop 3D printers is increasing due to their applications in research, education, and sustainable manufacturing [28]. The most common FDM 3D printing materials are polylactic acid (PLA), acrylonitrile butadiene styrene (ABS), and their different fusions. High-end printers utilize more advanced materials with better properties, such as higher heat resistance, flexural strength, tensile strength, impact resistance, and rigidity.

Ozsoy et al. [29] investigated the mechanical properties of PLA and ABS. A tensile, compression, and 3-point bending test was conducted. It was discovered that both materials' mechanical properties depend on the infill settings. The mechanical properties were greatly improved by increasing the filling density. PLA had higher compressive strength than ABS, however, ABS showed more ductility due to their difference in molecular structure. Raj et al. [30] studied PLA components to determine if they can be a suitable replacement for ABS components. The PLA components were subjected to various mechanical and degradation tests. It was concluded that PLA was eco-friendly and possessed the strength needed to produce plastic components, especially biomedical ones.

Surface finish is a concern when it comes to using Fused Deposition Modeling (FDM) 3D printers. Objects printed usually need post-processing surface finishing, such as sanding. Optimization of print parameters from the slicing software settings can substantially improve the object surface finish. Gordeev et al. [31] evaluated the impact of significant printing parameters on the surface quality of the resulting print. The parameters considered were wall thickness, type of the internal filling of the walls, print speed, extrusion temperature, and filament flow rate. The experiment showed that thin-walled printed objects needed infills to have a better surface finish. Conclusively, different print parameters need to be tweaked based on the object's geometry to have a great surface finish that will not require much post-processing.

There are still just a few applications of additive manufacturing, such as 3D printing, in developing nations, despite the growing global switch from subtractive to additive manufacturing. This is because teaching and research in additive manufacturing are unpopular and challenging in higher education institutions in underdeveloped countries, due to the high cost of purchasing and importing 3D printing machines. It is also frequently challenging to maintain imported 3D printing equipment and replace damaged parts. When the need occurs, people often struggle to repair and replace accessories, particularly plastic ones that deteriorate quickly. Therefore, it is necessary to design and build low-cost, highly accessible 3D printing machines utilizing readily available materials to create plastic components and accessories for teaching and research purposes in higher education institutions in developing countries.

2. Methodology

2.1. Materials

Table 1 presents the specifications of the component and materials used to fabricate the 3D printing machine. The components were selected based on design specifications, durability, and availability.

Table 1. Component and material used for the fabrication of the 3D printing machine.

Item	Quantity	Specification	Function
Frame (PVC pipe and fittings)	17	As determined by the calculations and print volume	Serves as chassis on which components are placed
Stepper motor	5	NEMA 17, 420N mm, 600 rpm	Generates torque for the movement of parts
Filament	1 Spool	Poly-lactic Acid (PLA)	Material from which part is printed
Extruder	1	MK8, 0.4 mm	Deposits the plastic filament on the bed

Table 1. Cont.

Item	Quantity	Specification	Function
Bed	1	150 × 120 × 10 mm of wood	A platform where the molten plastic is deposited
Timing belt	2	V-Belt, 5 mm wide	Transfers motor drive to move bed and extruder along y and x-axis, respectively
Pulley	2	2 mm pitch, 12.5 diameter	Serves as a point of attachment to transfer motion to the belt
Leadscrews	2	2 mm lead, 240 mm	To move the extruder head along z-axis
Steel rods	6	8 mm and 6 mm	Serves as a rail on which the bed and extruder move
Ball bearings	2	5 × 16 × 5 mm	Supports rotating belt
Linear bearings	7	8 mm and 6 mm	Carriage is mounted upon them and slides along a steel rod
Coupler	2	5 mm to 8 mm	Transfers the motor drive to the leadscrew
End stop	3	Mechanical type	Prevents the bed and extruder from moving past their range
Fan	1	DC 12V	Provides active cooling of the top printed layer
User interface and connectivity	1	LCD	Controls the 3D printer without a computer connection
Controller board	1	ATMEGA1284P	Directs the motion components based on commands sent from a computer and interprets input from the sensors
Printed Parts	1 set	As determined by the structure of the attached components	Holds components in place

2.2. Methods

2.2.1. Design Consideration

The essential factors considered in the design of the 3D printing machine are the cost of construction, size, sturdiness, assembling, availability of materials, and application. The machine’s overall cost must be low to be affordable for people in developing countries. The design of the 3D printer was carried out considering the print build volume of 10 × 10 × 10 cm³, which is the maximum geometry size of an obtained object. The machine was designed to print objects with polylactic acid (PLA), a bio-plastic and thermoplastic monomer made from agricultural produce, such as corn starch or sugar cane. Since it does not emit toxic fumes when heated, PLA is considered safer to use for experiments on 3D printing in schools and colleges.

Semi-permanent assembly method was adopted in the design. This ensures the machine’s structural stability, easy maintenance, and durability. Materials that are readily and locally available were considered for the fabrication of the machine. This is to ensure the easy replacement of parts when the need arises. Also, materials that can withstand the vibratory forces due to the motion of the electric motion were considered. The design stage also considered the machine’s durability and structural stability.

2.2.2. Design Calculation

Design of the Stepper Motor

The linear velocity *v* of the stepper motor is calculated using Equation (1) [32].

$$v = r\omega; \omega = \frac{2\pi N}{60} \tag{1}$$

where *r* is the radius of curvature of circular path = 6.25 mm; ω is the angular speed of the motor; *N* is the constant speed of the motor = 600 rpm. By computation, *v* = 392.69 mm/s.

The force due to the electric motor is calculated using Equation (2).

$$\text{Force} = \frac{\text{Torque}}{\text{The radius of curvature of the circular path}} \tag{2}$$

By computation, force = 67.2 N.

Therefore 6.72 kg can be pulled over a distance of 392.69 mm in one second using NEMA 17.

2.2.3. Design of Timing Belt

The width of the belt is calculated using Equation (3) [32].

$$w = \frac{Ff}{\sigma t} \quad (3)$$

where w is the width of the belt; σ is the ultimate strength of polyurethane = 20.77 MPa; F is the force of the electric motor; f is the factor of safety = 2; t is the belt thickness = 1.3 mm. By computation, $w = 4.98$ mm. The standard width = 5 mm.

The allowable tensile load on this belt is 134.4 N, and since the force exerted by the motor is 67.2 N, which is far less than the allowable tensile load, the selected belt would not fail under the design conditions.

The length of each belt is calculated using Equation (4) [32].

$$L = \frac{\pi}{2}(D + d) + \sqrt{4c^2 + D^2 + d^2} \quad (4)$$

where D is the diameter of pulley; d = diameter of bearing; c = centre distance between two pulleys; L = length of timing belt; T = thickness of timing belt.

For belt 1 (x-axis), $D = 16$ mm, $d = 12.5$ mm, $c = 310$ mm, and $T = 1.3$ mm. Using Equation (4), L_1 (x-axis belt) = 665.10 mm.

Belt 2 (y-axis) has slightly different dimensions ($D = 16$ mm, $d = 12.5$ mm, $c = 290$ mm, and $T = 1.3$ mm). Using Equation (4), L_2 (y-axis belt) = 625.12 mm.

2.2.4. Deflection of Frame

The 3D printer frame was analyzed, and reaction forces in the frame section was determined. The maximum deflection occurred at the x-axis movement assembly section, which carries the extruder head. The natural frequency of a body is directly proportional to the square root of stiffness, and stiffness is inversely proportional to deflection. In other words, deflection is inversely proportional to the natural frequency. The maximum deflection was determined to be 14.3 microns, which is considered negligible [13]. Hence, vibratory forces were ignored.

2.2.5. Slicing Software and Firmware

Firmware is a computer program that provides an operating environment that allows devices to run on the operating system. It helps the device perform all monitoring functions associated with the 3D printing machine. Repetier, open-source firmware for most RepRap family 3D printers, was used as the firmware of the 3D printer. The firmware supports printing from both USB and SD cards with folders, and utilizing look-ahead trajectory planning. It runs via the printer's mainboard. It controls all the activities on the machine and coordinates the buttons, heaters, steppers, lights, sensors, LCD, etc., using G-code as the control language.

Cura, produced by Ultimaker, was used as the slicing software. The software was selected because it supports STL, 3MF, and OBJ 3D file formats. Also, Cura can import and convert 2D images (.JPG, .PNG, .BMP, and .GIF) to 3D extruded models. It allows the user to work and print multiple models. Figures 1 and 2 show the CAD model of the 3D printing machine.

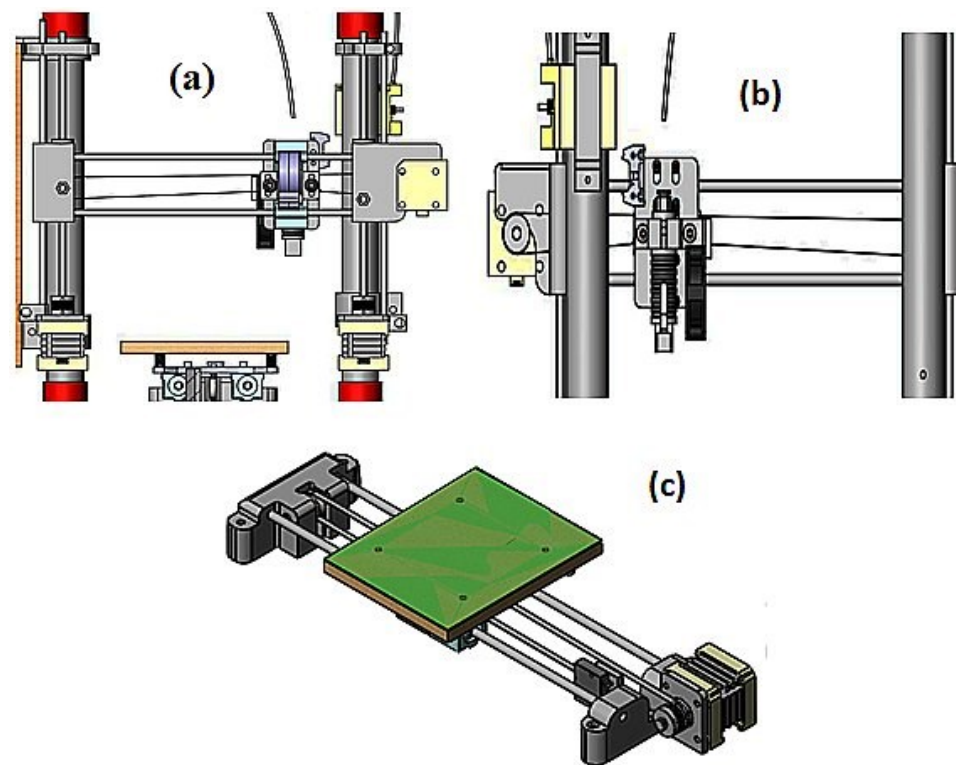

Figure 1. Assembly CAD Model- (a) z-axis Movement, (b) x-axis Movement, and (c) y-axis Movement.

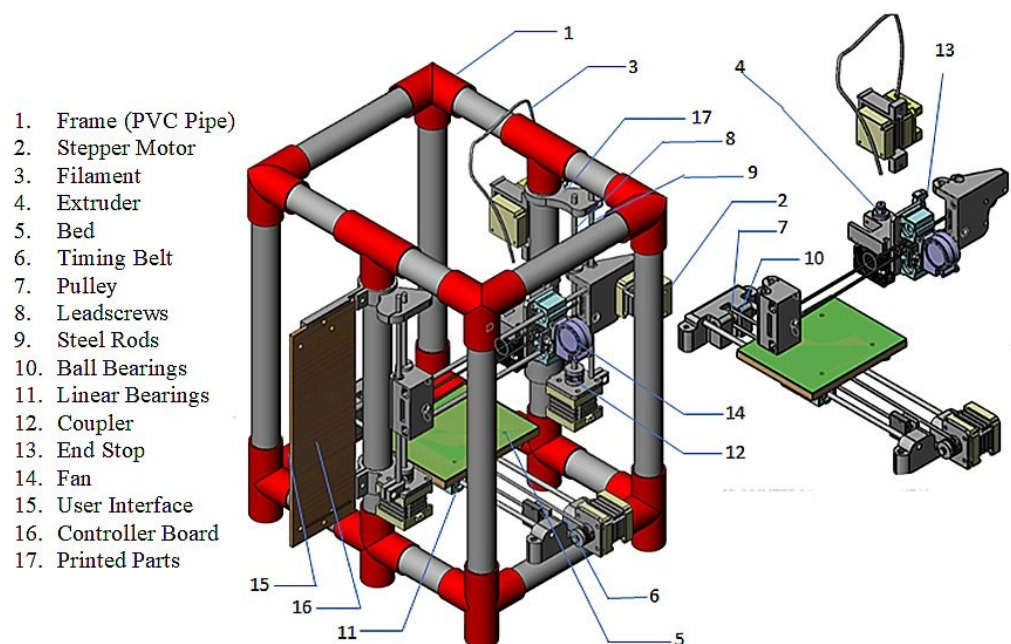

Figure 2. The isometric view of the 3D printer CAD model.

3. Results and Discussion

Figure 3 shows pictorial views of the constructed 3D printer. The machine was first tested by verifying the motion system, followed by printing an object. While testing the printer’s motion system, it was discovered that the primary method of checking the correctness of the x, y, and z axes motion system is to manually move the print head and bed fully through the x, y, and z axes, respectively. A smooth movement with no obstruction shows that the axes’ positioning is correct, provided the frame holding the elements is in position.

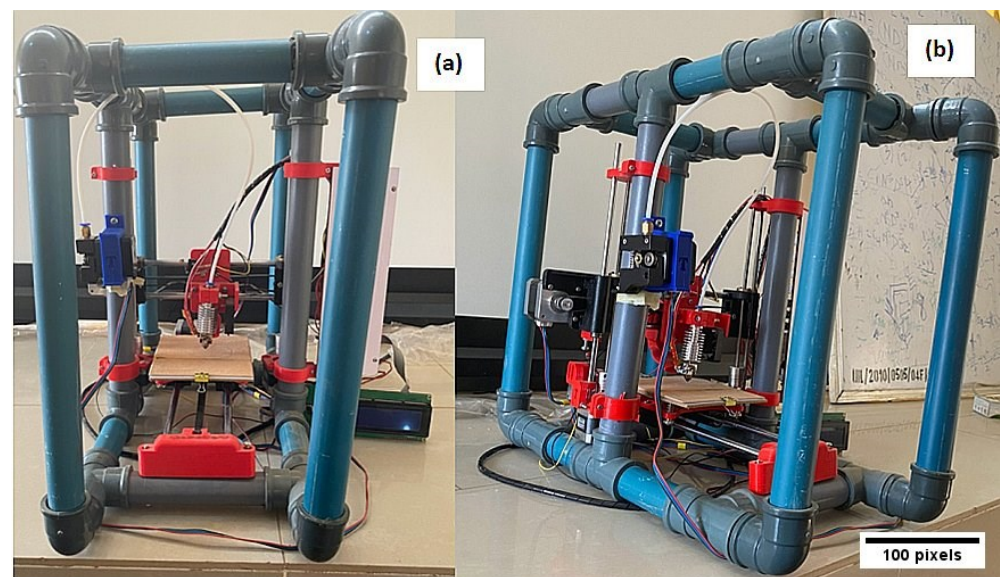

Figure 3. The constructed 3D Printer—(a) front view and (b) side view.

Operation of the Fabricated 3D Printer

These steps can be followed to print an object using this 3D printer:

- i. design the model using any Computer-Aided Design (CAD) software and ensure the model is exported in a 3D printing compatible format such as .STL or .OBJ;
- ii. load the model file into a slicing software with the necessary settings, such as the speed, temperature, layer height, shell, thickness, fill, support, and filament settings;
- iii. save the model G-Code, and automatically the G-Code of the model following earlier inputted settings will be generated and saved as a file;
- iv. transfer the saved file to an SD card and then insert it into the slot on the printer's motherboard;
- v. connect the printer to the power source and calibrate the printer by ensuring the bed is leveled and all axes movement mechanisms are functioning correctly;
- vi. insert the filament and print the model from the file on the SD card and after the model has finished printing, retrieve it from the bed and, if necessary, post-process the print.

Different test models were printed to determine the accuracy and efficiency of the 3D printer, and its suitability for replacing the imported 3D printers. Objects and parts from different fields of studies (engineering - gears; medical - prosthetics and nose masks) were printed to evaluate the applicability of the printer, and components of the 3D printer were printed to test the printer's self-replication. All the printer's parts, except for the electrical components, could be printed.

There are certain geometries that are difficult to print. This is because an FDM 3D printer functions by depositing semi-molten plastic layer by layer to create an object, and the layer supports each new layer underneath it. Therefore, if the preceding layer does not support an overhang structure, the new layer falls, resulting in a catastrophic print. Before printing starts, the object design and geometry are analyzed to determine the need for a support structure. If support is needed, it can be simply incorporated from the slicing software input settings. After the printing, the support structure is carefully removed from the object. The support structures are designed to be broken off easily. Figure 4 shows the human foot and outer ear with their support structures. Samples of other printed objects are shown in Figure 5. The specification of the constructed 3D printing machine is presented in Table 2, while the bill of engineering materials and evaluation is shown in Table 3.

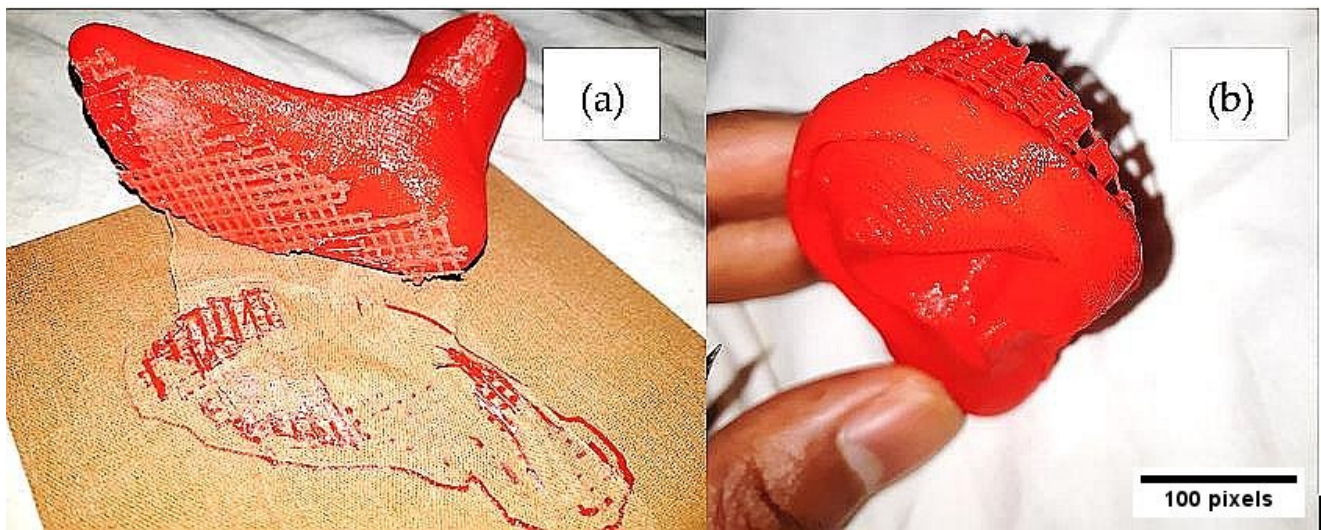

Figure 4. Illustration of overhangs: (a) human foot with a support structure; (b) human outer ear with a support structure.

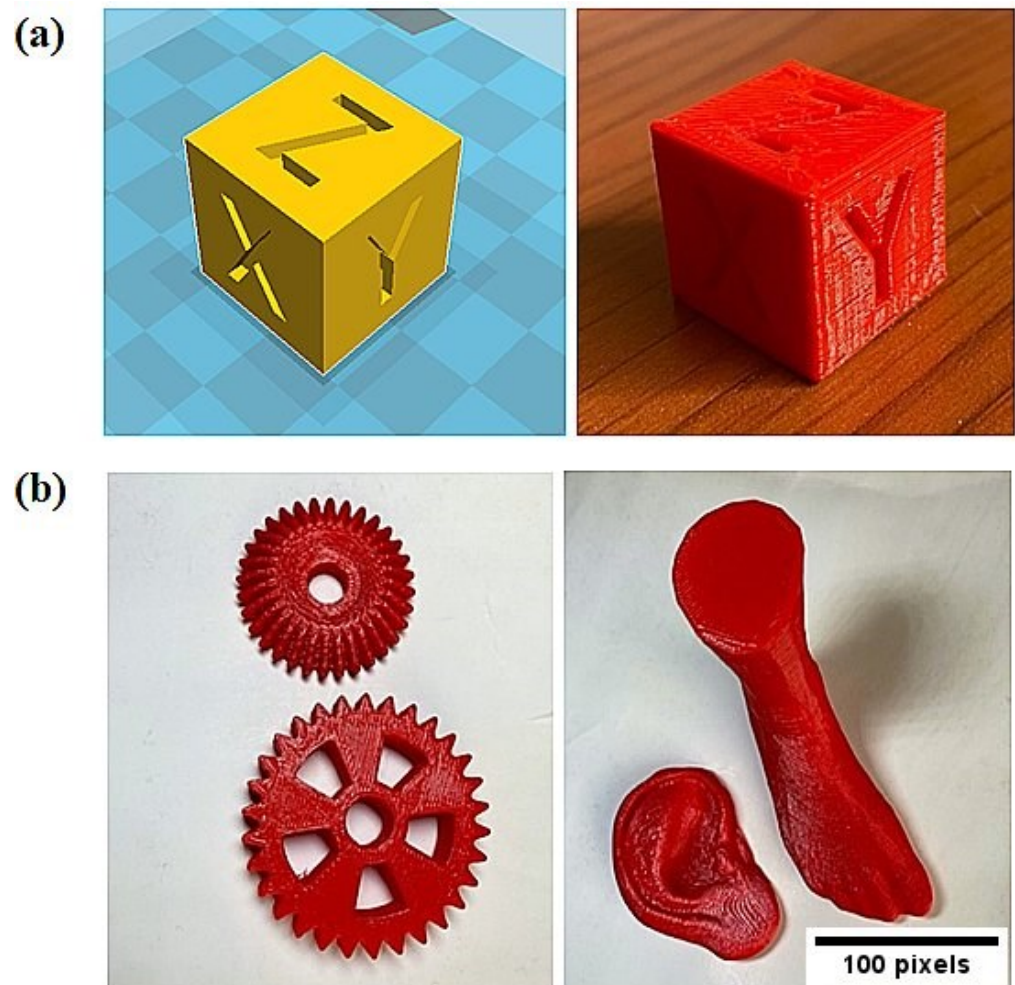

Figure 5. Cont.



Figure 5. Designed objects printed using the fabricated 3D printing machine: (a) calibration cube; (b) bevel gear, spur gear, outer human ear, and foot; (c) nose mask; (d) fixture holding the electric motor controlling the z-axis.

Table 2. Specification of the constructed 3D printer.

Items	Specifications
Build volume	100 × 100 × 100 mm ³
Method	Fused deposition modelling
Printer size	500 mm (L) × 380 mm (W) × 425 mm (H)
Printer weight	3.95 kg
Number of extruders	1
Filament diameter	1.75 mm
Nozzle diameter	0.4 mm
Filament type	PLA
Layer resolution height	100 microns
Power supply	DC12 V, 5.0 A
Power consumption	240 V, 50-60 Hz
Connectivity	USB, SD card

Table 3. The bill of engineering material and evaluation.

Material	Quantity	Cost (Naira, ₦)
Frame (PVC pipe and fittings)	17	4200
NEMA 17 stepper motor	5	15,000
PLA filament	1 Spool	17,000
MK8 extruder	1	3300
Bed	1	1000
Timing belt and pulley	2	1500
Leadscrews	2	3000
Steel rods	6	7200

Table 3. Cont.

Material	Quantity	Cost (Naira, ₦)
Ball bearings	2	500
Linear bearings	7	8750
Coupler	2	1000
End stop	3	2200
DC fan	1	500
User interface and connectivity	1	15,500
Printed parts	1 Set	20,000
Screws, bolts, nuts, and springs	1 Set	1000
Miscellaneous		3000
Total		104,650

Total price equivalence in dollars is \$233 (\$1 = ₦450). It should be noted that these are retail prices, and the cost of fabrication could be about 50% cheaper when parts are purchased in bulk for mass production.

4. Conclusions

A low-cost-high-accessibility fused deposition modeling 3D printer was designed and constructed in this study using locally available materials. The following conclusions could be drawn from the study:

- i. The design of the frame was made robust using PVC pipes, and commercial off-the-shelf components were used where possible, especially for the electrical parts.
- ii. The 3D printer is self-reproducible, which means all parts of the machine may be manufactured using the same 3D printer since the fixtures are made of PLA plastic, except for the PVC frame, wooden bed, and electrical parts.
- iii. The recommended distance between the nozzle tip and the bed is 0.1 mm.
- iv. The printer's accuracy level was shown by the printed object's dimensions correctness compared to the digital design, which gave a percentage error of 0.74%.
- v. The machine performed satisfactorily with a total cost of ₦104,650 (\$233) and can be used in place of imported 3D printers in developing nations.

Author Contributions: A.D.A. conceptualized and carried out the construction of the printer. K.R.A. supervised the research. S.E.I. and A.D.A. wrote the article. E.T.A. review and edit the article. All authors have read and agreed to the published version of the manuscript.

Funding: This research received no external funding.

Data Availability Statement: The data supporting this study's findings are available within the article.

Conflicts of Interest: The authors declares no conflict of interest.

References

1. Huang, W.; Zhang, L.; Li, W.; Sun, J.; Liang, W.; Song, X.; Mao, X.; Wang, Z. Various Types and Applications of Additive Manufacturing. *Int. Conf. Appl. Math. Model. Simul. Optim.* **2019**, 377–381. [[CrossRef](#)]
2. Jasveer, S.; Jianbin, X. Comparison of Different Types of 3D Printing Technologies. *Int. J. Sci. Res. Publ.* **2018**, *8*, 1–9. [[CrossRef](#)]
3. Bhusnure, O.G.; Gholve, S.V.; Sugave, B.K.; Dongre, R.C.; Gore, S.A.; Giram, P.S. 3D Printing & Pharmaceutical Manufacturing: Opportunities and Challenges. *Int. J. Bioassays* **2016**, *5*, 4723–4738.
4. Prabhu, T. Modern Rapid 3D printer—A Design Review. *Int. J. Mech. Eng. Technol.* **2016**, *11*, 29–37.
5. Pekgor, M.; Nikzad, M.; Arablouei, R.; Masood, S. Materials Today: Proceedings Sensor-based filament fabrication with embedded RFID microchips for 3D printing. *Proceedings* **2021**, *46*, 124–130.
6. Carrasco-correa, E.J.; Francisco, E. The emerging role of 3D printing in the fabrication of detection systems. *Trends Anal. Chem.* **2021**, *136*, 116177. [[CrossRef](#)]
7. Ruberu, K.; Senadeera, M.; Rana, S.; Gupta, S.; Chung, J.; Yue, Z.; Venkatesh, S.; Wallace, G. Coupling machine learning with 3D bioprinting to fast track optimisation of extrusion printing. *Appl. Mater. Today* **2021**, *22*, 100914. [[CrossRef](#)]

8. Farhan, M.; Alam, A.; Ateeb, M.; Saad, M. Materials Today: Proceedings Real-time defect detection in 3D printing using machine learning. *Mater. Today Proc.* **2021**, *42*, 521–528. [[CrossRef](#)]
9. Popovski, F.; Mijakovska, S.; Popovska, H.D.; Nalevska, G.P. Creating 3D Models with 3D Printing Process. *Int. J. Comput. Sci. Inf. Technol.* **2021**, *13*, 59–68. [[CrossRef](#)]
10. Fettig, A. Purposes, Limitations, and Applications of 3D Printing in Minnesota Public Schools. *Culminating Proj. Inf. Media.* **2017**, *1*, 1–52.
11. Ilhan, E.; Ulag, S.; Sahin, A.; Karademir, B.; Ekren, N.; Kilic, O.; Sengor, M.; Kalaskar, D.M.; Nuzhet, F.; Gunduz, O. Fabrication of tissue-engineered tympanic membrane patches using 3D-Printing technology. *J. Mech. Behav. Biomed. Mater.* **2021**, *114*, 104219. [[CrossRef](#)]
12. Xenikakis, I.; Tsongas, K.; Tzimtzimis, E.K.; Zacharis, K.; Theodoroula, N.; Kalogianni, E.P.; Demiri, E.; Vizirianakis, I.S.; Tzetzis, D.; Fatouros, D.G. Fabrication of hollow microneedles using liquid crystal display (LCD) vat polymerization 3D printing technology for transdermal macromolecular delivery. *Int. J. Pharm.* **2021**, *597*, 120303. [[CrossRef](#)]
13. Adesiji, A.D. Design and Construction of a 3d Printer. Bachelor's Thesis, Department of Mechanical Engineering, University of Ilorin, Ilorin, Nigeria, 2021.
14. Rayna, T.; Striukova, L. From rapid prototyping to home fabrication: How 3D printing is changing business model innovation. *Technol. Forecast. Soc. Chang.* **2016**, *102*, 214–224. [[CrossRef](#)]
15. Sung, J.; So, H. 3D printing-assisted fabrication of microgrid patterns for flexible antiadhesive polymer surfaces. *Surf. Interfaces* **2021**, *23*, 100935. [[CrossRef](#)]
16. Zhou, X.; Zhou, G.; Junka, R.; Chang, N.; Anwar, A.; Wang, H.; Yu, X. Fabrication of polylactic acid (PLA) -based porous scaffold through the combination of traditional bio-fabrication and 3D printing technology for bone regeneration. *Colloids Surf. B Biointerfaces* **2021**, *197*, 111420. [[CrossRef](#)]
17. Al-maliki, J.Q.; Al-maliki, A.J.Q. The Processes and Technologies of 3D Printing. *Int. J. Adv. Comput. Sci. Technol.* **2015**, *4*, 161–165.
18. Burleson, J.; Dipaola, C. 3D Printing in Spine Surgery. In *3D Printing in Orthopaedics: Subspecialties*; Elsevier: Amsterdam, The Netherlands, 2019; pp. 105–122. [[CrossRef](#)]
19. Zaghoul, M.Y.M.; Zaghoul, M.M.Y.; Zaghoul, M.M.Y. Developments in polyester composite materials—An in-depth review on natural fibres and nano fillers. *Compos. Struct.* **2021**, *278*, 114698. [[CrossRef](#)]
20. Zaghoul, M.M.Y.; Mohamed, Y.S.; El-Gamal, H. Fatigue and tensile behaviors of fiber-reinforced thermosetting composites embedded with nanoparticles. *J. Compos. Mater.* **2019**, *53*, 709–718. [[CrossRef](#)]
21. Zaghoul, M.M.Y.; Zaghoul, M.M.Y. Influence of flame retardant magnesium hydroxide on the mechanical properties of high density polyethylene composites. *J. Reinf. Plast. Compos.* **2017**, *36*, 1802–1816. [[CrossRef](#)]
22. Zaghoul, M.M.Y.; Zaghoul, M.Y.M.; Zaghoul, M.M.Y. Experimental and modeling analysis of mechanical-electrical behaviors of polypropylene composites filled with graphite and MWCNT fillers. *Polym. Test.* **2017**, *63*, 467–474. [[CrossRef](#)]
23. Zaghoul, M.Y.; Zaghoul, M.M.Y.; Zaghoul, M.M.Y. Influence of Stress Level and Fibre Volume Fraction on Fatigue Performance of Glass Fibre-Reinforced Polyester Composites. *Polymers* **2022**, *14*, 2662. [[CrossRef](#)]
24. Raja, N.; Sung, A.; Park, H.; Yun, H. Low-temperature fabrication of calcium deficient hydroxyapatite bone scaffold by optimization of 3D printing conditions. *Ceram. Int.* **2021**, *47*, 7005–7016. [[CrossRef](#)]
25. Xiao, X.; Jiang, X.; Yang, S.; Lu, Z.; Niu, C.; Xu, Y.; Huang, Z.; Kang, Y.J.; Feng, L. Solvent evaporation induced fabrication of porous polycaprolactone scaffold via low-temperature 3D printing for regeneration medicine researches. *Polymers* **2021**, *217*, 123436. [[CrossRef](#)]
26. Sevel, P.; Srinivasan, D.; Balaji, A.J.; Gowtham, N. Design & Fabrication of Innovative Desktop 3D Printing Machine. *Mater. Today Proc.* **2020**, *22*, 3240–3249.
27. Patel, V.; Joshi, U.; Joshi, A. Opportunities in 3D Printing for Nanocomposite Materials: A Review. *J. Emerg. Technol. Innov. Res.* **2019**, *6*, 367–372.
28. O'Connell, J.; Haines, J. How Much Does a 3D Printer Cost in 2022? 2022. Available online: <https://m.all3dp.com/2/how-much-does-a-3d-printer-cost/> (accessed on 20 July 2022).
29. Ozsoy, K.; Ercetin, A.; Cevik, Z.A. Comparison of Mechanical Properties of PLA and ABS Based Structures Produced by Fused Deposition Modelling Additive Manufacturing. *Eur. J. Sci. Technol.* **2021**, *27*, 802–809.
30. Raj, S.A.; Muthukumaran, E.; Jayakrishna, K. A Case Study of 3D Printed PLA and Its Mechanical Properties. *Mater. Today Proc.* **2018**, *5*, 11219–11226. [[CrossRef](#)]
31. Gordeev, E.G.; Galushko, A.S.; Ananikov, V.P. Improvement of quality of 3D printed objects by elimination of microscopic structural defects in fused deposition modeling. *PLoS ONE* **2018**, *13*, e0198370.
32. Kuurmi, R.S.; Gupta, J.K. *A Textbook of Machine Design*, 1st ed.; EURASIA Publishing House (PVT.) Ltd: Kolkata, India, 2005.