

Development of a Wheelchair Lifting System with Height Levelling and Side Transfer

Kian Sek Tee^{1*}, Muhamad Amirul Yusman Bin Yazid¹, Eugene Low¹, Elmy Johana Mohamad¹, Chin Fhong Soon¹, Toong Hai Sam², Jaysuman Bin Puspanathan³

¹Faculty of Electrical and Electronic Engineering, Universiti Tun Hussein Onn Malaysia, Parit Raja, Batu Pahat, Johor, 86400, MALAYSIA

²Faculty of Business, Communications and Law (FOBCAL), INTI International University, Persiaran Perdana BBN, Putra Nilai, Nilai, Negeri Sembilan, 71800, MALAYSIA

³School of Biomedical Engineering & Health Science, Universiti Teknologi Malaysia, Skudai, Johor, MALAYSIA

Corresponding author* email: xxx@xxx.my

Accepted 3 March 2021, available online 31 March 2021

ABSTRACT

Wheelchair Lifting System is one of the alternative solution to help the disabled person which have difficulties in moving from the wheelchair into the car easily. The transferring process of these disabled person from getting in or out of the car is a delicate process. Most of the situation, two or more caregivers are required, and they also need a lot of energy and time to complete that process. It is also reported that 1 in 3 caregivers might develop back injuries. Most of the injuries were occurring because the patient is heavy to lift. Besides that, the caregivers may exposed to awkward positions during the transferring process from the wheelchair to the car seat. The support device such as mechanism lifting system is needed to move the disabled person. Various tests have been done to verify the functionality of the device. The results show that wheelchair is able to carry the maximum weight of 100kg to the car seat successfully.

Keywords: Wheelchair lifting system, wheelchair, disabled person, screw mechanical jack

1. Introduction

People with Disabilities (PWD) associated with lower limbs are in upward trend all around the world. According to the Ministry of Health, Labour and Welfare of Japan, about a number of 3,480,000 of disabled persons are reported and a number of 760,000 persons among them are severely disabled [1]. In order to improve mobility of the disabled person, most of them has chosen to use wheelchair as an aid to their mobility impairment

The wheelchair is the type of chair that come out with wheels and used by people that have difficulties in walking because they are injured, sick and disabled. The first wheelchair was introduced in 1595 and King of Spain which is Phillip II is the first person that own rolling chair with footrests [2]. After centuries of improvement on the wheelchair, current general medical wheelchairs are constructed with a seat and seat back supported on a rectangular frame with two large wheels at both sides and two small front wheels which may swivel and have a footrest [3]. This device comes with a various design that allowing the user to turning the rear wheels either by electric propulsion by motors or by hand. There are also have back handles behind the seat to allow it to push by another person.

Besides that, engineering science has also come up with a lot innovative ideas in order to further improve the mobility for the disabled persons. Assistive technology for mobility includes wheelchairs, exoskeletons, walking devices, lifting aids and so on [4-9]. In real life, the patient required the help of an assistance to use the device. This situation includes someone help to push a wheelchair, to help in lifting from the bed, to support using the toilet or to help in lifting for them getting in or out from the car [10]. This paper presents a lifting mechanism which enable the disabled person to transfer from the wheelchair into the vehicle without much external aid given.

2. Methodology

2.1 System Overview

The main concept of the proposed wheelchair lifting system is that the user can transfer him or herself from the wheelchair seat to the car seat without the aid from anybody. In this project, car model Perodua Axia is selected as the destination of the transferring process. Figure 1 illustrates the overview on the wheelchair lifting system. Firstly, the wheelchair is stopped next to the car seat as shown in figure 1(a). Next, the user is lifted up by the mechanical jack using the control button to control the wheelchair seat's height as shown in figure 1(b). Then, the armrest is folded to create the bridge in between the wheelchair and the car seat in order for the user to be transferred as shown in figure 1(c). Lastly, figure 1(d) shows that the user has completely and successfully transferred to the car seat.

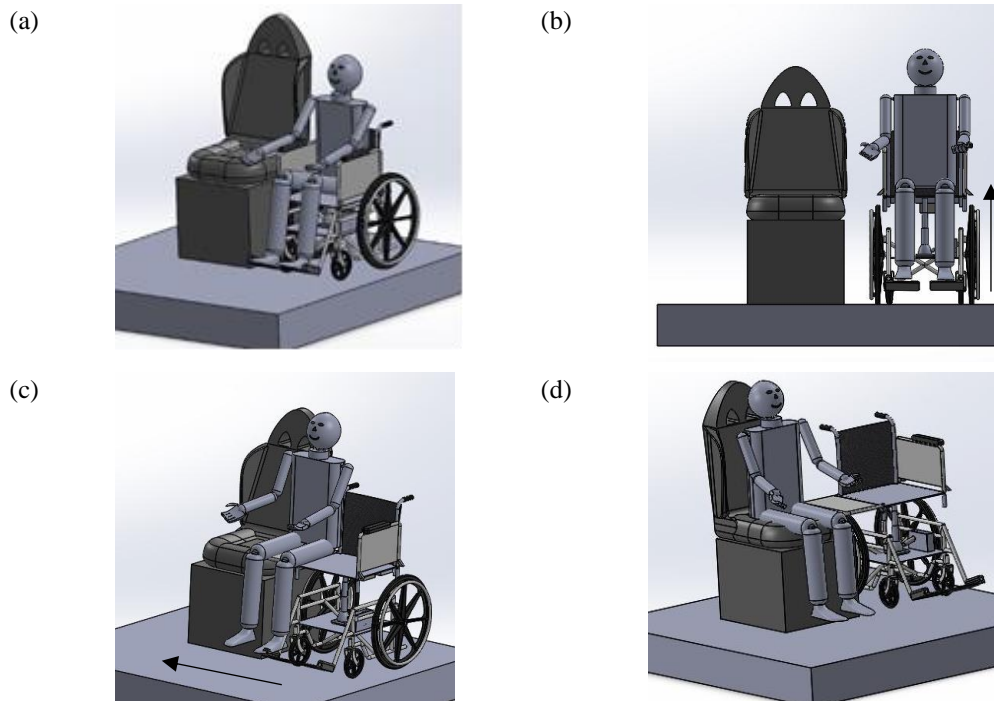

Figure 1. Overview on the wheelchair lifting system; (a) The wheelchair is stopped next to the car seat; (b) The user is lifted upward by mechanical jack; (c) The armrest is folded and the transfer process is started; (d) The user is successfully transferred to the car seat

2.2 Mechanical Design

The medical wheelchair is essential to produce the good performance and provide the proper fit with posture support for the disabled person. In this project, normal medical wheelchair is selected to be modified. For modification on the wheelchair, it is distributed into two main parts which are bottom part and upper part.

The bottom part is the most important part of modification since the bottom part carry the whole weight of the wheelchair and the user. In order to enable the mechanical jack to lift up the whole upper part of the wheelchair to the desired height safely, the material for the body frame of the bottom part need to be strong enough to carry the range of weight between 70kg-100kg. In this case, metal is used to modify the body frame of the wheelchair. The design of the bottom part of the wheelchair is as shown in figure 2. The metal base plate with a thickness of 10mm is installed at the middle of the bottom part to locate and support the weight of mechanical jack, motor driver and battery supply.

The upper part contains backrest, armrest, cushion, push handle and seat. Metal is also selected as the material used for modification. For the cushion cover and back rest, the material used is semi leather to increase the comfort of the user comfortable. The square metal plate below the seat of the wheelchair will act as the support for the mechanical jack cylinder to lift up the whole upper part. The armrest will modified to foldable type in which it able to act as the bridge during the transfer process. The design of the upper part of the wheelchair is shown in figure 3.

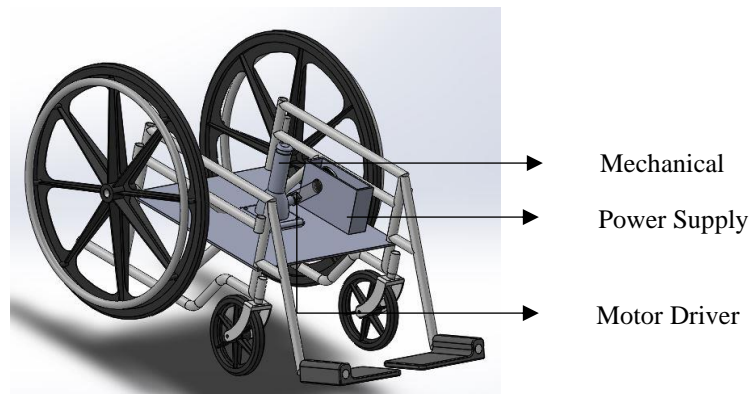

Figure 2. Bottom part of wheelchair

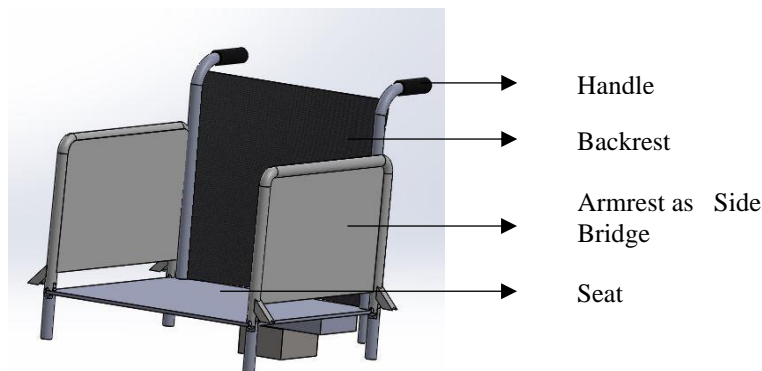

Figure 3. Upper part of wheelchair

The screw mechanical jack is a portable device with great force to raise up and lower down the heavy load which consist of the screw mechanism in it. There are two types screw mechanical jack available in the market such as mechanical jack and hydraulic jack. The mechanical jack can be operated by power driven or by the user's strength themselves. The hydraulic jack raised or lowered the load by hydraulic force in which the hydraulic jack consists of piston mechanism and cylinder. In this project, the mechanical jack is used because it has lower cost as compared to the hydraulic jack. Besides that, in terms of space available at the base of the wheelchair, the hydraulic jack is less suitable since it is larger in size. Figure 4(a) shows the mechanical jack in fully retract position and figure 4(b) shows the mechanical jack in fully extend position. Table 1 shows the specification of the mechanical jack.

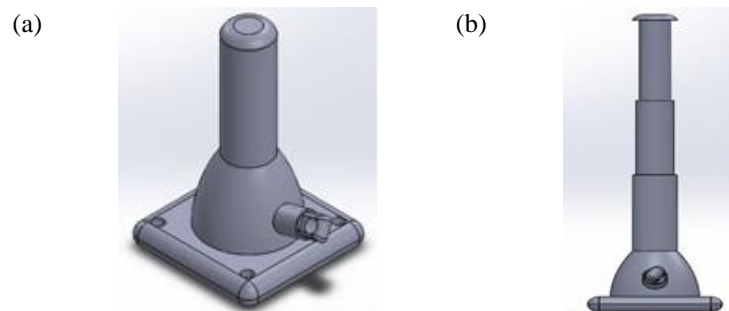

Figure 4. Mechanical Jack. Fully (a) retract; (b) extend

Table 1. Specification of mechanical jack

Detail	Value
Minimum height (Fully Retract)	180mm
Minimum height (Fully Extend)	390mm
Maximum weight supported	2 tons

2.3 Mechanical Design

Power window motor is a device which raise and lower the car window level. In this project, power window motor is selected as the driven power to the mechanical jack since it has higher torque to drive the mechanical jack as compare to other DC motor available. The specification of the power window motor is shown in Table 2.

Table 2. Specification of power window motor

Detail	Value
Voltage rating	12VDC
No load speed	85 ± 15RPM
Rated speed	60 ± 15RPM
Current (No load)	5A
Rated current (load)	15A
Stall current (locked)	28A at 12V
Rated torque	30Kgcm (2.9Nm)
Stall torque (locked)	100 ± 15Kgcm (~10Nm)

The power window motor was located beside the mechanical jack which a customized joint is used to connect the gear of the motor and the screw of the mechanical jack. Figure 5 shows the connection between the power window motor and the mechanical jack by using the customized joint.

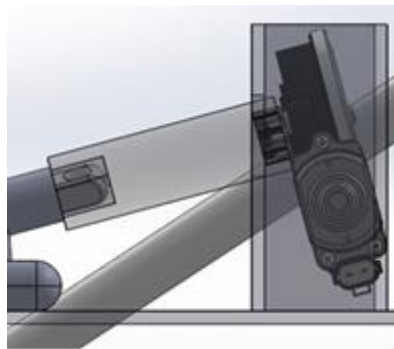

Figure 5. Connection between the power window motor and the mechanical jack

A schematic diagram is created to control the movement of mechanical jack. The schematic diagram is shown in figure 6. A 12V DC battery is used as the power supply to power up the whole circuit. Both up and down electromechanical relays switch are important to control the direction of power window motor either in clockwise or anticlockwise.

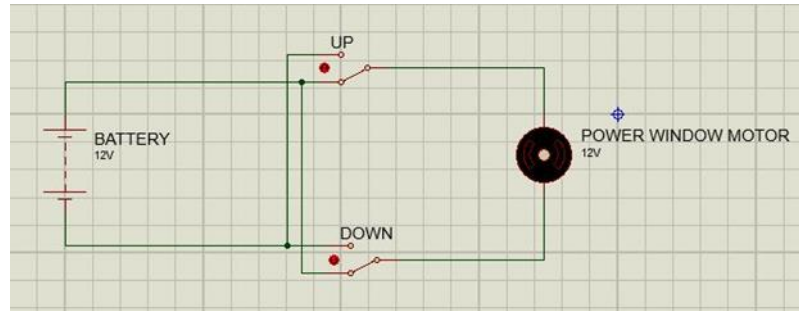

Figure 6. Schematic Diagram

2.1 Final 3D Model Design

Figure 7 shows the final 3D model design of the whole wheelchair lifting system. This design is drawn accordingly to the actual standard wheelchair dimension and the actual size of mechanical jack. The 3D model of the system is designed using SolidWorks before the hardware assembly process. It is vital as SolidWorks able to guide the construction of hardware according to many aspects such as calculation, components and material that need to use in constructing hardware. The user also can do measurement and avoid any error before proceeding with hardware design.



Figure 7. 3D model of wheelchair lifting system using SolidWorks

3. Results and Discussion

3.1 Hardware Assembly

Figure 8 shows the complete wheelchair lifting system. All the welding process are done properly and carefully to avoid any defects occur before any test is carried out. All the components are connected and assembled accordingly to prevent any bad connections between the components. Some physical properties have been measured and calculated since the wheelchair has been modified from the original product. Table 3 shows the dimension of the wheelchair before and after lifted. Table 4 shows the weight of the wheelchair before and after parts assembly.

3.1 Time Response

In this test, five weights at 60kg, 70kg, 80kg, 90kg and 100kg are used to determine the time response of the wheelchair lifting system to the different weight. The weight is located at the centre of the seat and it's lifted upwards to the maximum height. The time taken for the weight to reach to the maximum height is recorded as shown in Table 5 and the graph is plotted as shown in figure 9. According to the results obtained, the heavier the weight of the sample, the longer the time response for the weight to achieve maximum height.



Figure 8. Complete wheelchair lifting system

Table 3. Dimension of the wheelchair

Detail	Dimension
Normal situation	L: 939mm x W: 533mm x H: 863mm
After lifting process	L: 939mm x W: 533mm x H:137 mm

Table 4. Weight of the wheelchair

Detail	Weight
Normal situation	15kg
After assembly components	23.5kg

Table 5. Time response of lifting

Sample	Weight (kg)	Time (s)
1	60	30
2	70	45
3	80	54
4	90	66
5	100	73

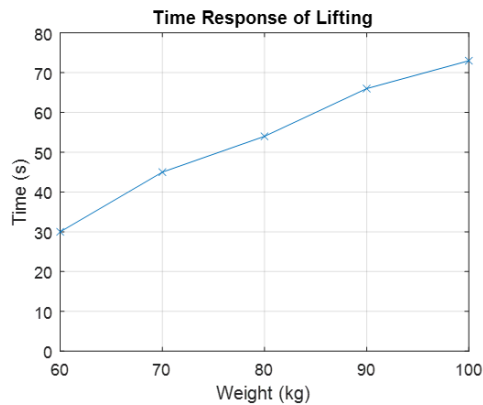

Figure 9. Graph of time response of lifting

3.1 Stability Change

The stability of the wheelchair is evaluated and compared between retract and extend position. The area of the base of the wheelchair calculated is 49354mm² in which the length and width are 114.3mm and 431.8mm respectively. The stability comparison ratio is calculated by using the formula as stated in Eq. 1 and the data are tabulated in Table 6. According to the results, it shows that the mechanical jack in retract position it is more stable than extend position.

$$\text{Stability comparison ratio} = \text{height (mm)} : \text{base (mm}^2\text{)} \quad (1)$$

Table 6. Stability comparison ratio

Detail	Height (mm)	Base (mm ²)	Ratio
Before lifting (Retract)	180	49354	274 : 1
After lifting (Extend)	390	49354	127 : 1

4. Conclusion

In conclusion, the wheelchair lifting system is an innovative technology which benefits the disabled person that use the wheelchair in their daily lives. It is able to transfer the user with a maximum weight of 100kg from the wheelchair into the car independently without any external help from the caregiver. In other words, it also reduces the risk of the caregiver from suffering the back pain due to heavy lifting and bad postures. The wheelchair lifting system could be improved by adding a slider to the side bridge for the user to slide into the car seat and deploying the side bridge for both side of the wheel chair.

Acknowledgement

The authors are grateful to the financial support by Postgraduate Research Grant (GPPS), Vote: U798, Universiti Tun Hussein Onn Malaysia.

References

- [1] Y. Mori, N. Sakai, and K. Katsumura, "Development of a Wheelchair with a Lifting Function," *Advances in Mechanical Engineering*, vol. 4, p. 803014, 2012.
- [2] H. L. Kamenetz, "A brief history of the wheelchair," *Journal of the history of medicine and allied sciences*, vol. 24, pp. 205-210, 1969.
- [3] S. Y. Araki, P. Florentino, M. Saito, M. Hernandez, E. Bock, L. Fuentes, I. Fujita, R. L. Stoeterau, D. Martins, and A. C. F. d. Arruda, "Computational modelling of an automatic wheelchair lift system for assistive technology," in *2017 3rd International Conference on Control, Automation and Robotics (ICCAR)*, 2017, pp. 448-452.
- [4] U. Onen, F. M. Botsali, M. Kalyoncu, M. Tinkir, N. Yilmaz, and Y. Sahin, "Design and actuator selection of a lower extremity exoskeleton," *IEEE/ASME Transactions on Mechatronics*, vol. 19, pp. 623-632, 2014.
- [5] A. Škraba, R. Stojanović, A. Zupan, A. Koložvari, and D. Kofjač, "Speech-controlled cloud-based wheelchair platform for disabled persons," *Microprocessors and Microsystems*, vol. 39, pp. 819-828, 2015.
- [6] V. V. Pande, N. S. Ubale, D. P. Masurkar, N. R. Ingole, and P. P. Mane, "Hand gesture based wheelchair movement control for disabled person using MEMS," *International Journal of Engineering Research and Applications*, vol. 4, pp. 152-8, 2014.
- [7] F. B. Taher, N. B. Amor, and M. Jallouli, "EEG control of an electric wheelchair for disabled persons," in *Individual and Collective Behaviors in Robotics (ICBR), 2013 International Conference on*, 2013, pp. 27-32.
- [8] M. E. Daud, Z. Hamid, and A. M. Desa, "Development of Multi-Purpose Wheelchair," in *Innovation & Commercialization of Medical Electronic Technology Conference (ICMET), 2015*, 2015, pp. 22-25.
- [9] T. Mo, Y. Sun, and Y. Yang, "New Mechanism Used in Standing Wheelchair," ed, 2014.
- [10] K. Rashid Ahmed, S. A. Razack, S. Salam, K. Vishnu Prasad, and C. Vishnu, "Design and Fabrication of Pneumatically Powered Wheel Chair-Stretcher Device," *International Journal of Innovative Research in Science, Engineering and Technology*, vol. 4, 2015.