

# The Variable Polarization XUV Beamline P04 at PETRA III: Optics, Mechanics and their Performance

Jens Viefhaus<sup>a</sup>, Frank Scholz<sup>a</sup>, Sascha Deinert<sup>a</sup>, Leif Glaser<sup>a</sup>,  
Markus Ilchen<sup>a</sup>, Jörn Seltmann<sup>a</sup>, Peter Walter<sup>a</sup>, Frank Siewert<sup>b</sup>

<sup>a</sup>*Deutsches Elektronen-Synchrotron DESY, Notkestraße 85, 22607 Hamburg, Germany*

<sup>b</sup>*Helmholtz-Zentrum Berlin (HZB) für Materialien und Energie,  
Albert-Einstein-Straße 15, 12489 Berlin, Germany*

---

## Abstract

The layout of the Variable Polarization XUV Beamline P04 at PETRA III is described with emphasis on selected examples of optics, mirrors and gratings. A precise characterization of the substrate or work piece, its performance inside the holder and of the surrounding mechanics is presented. This also includes a detailed characterization of the different beamline mechanics as a whole (grating unit, exit slit unit, re-focusing unit) including the environment.

*Keywords:* synchrotron radiation, x-ray optics, optic metrology, VLS-PGM

---

## 1. Introduction

The 6 GeV storage ring PETRA III [1] started operation in 2009 as one of the most powerful hard x-ray synchrotron radiation sources in the world. One of its 14 operating beamlines, the Variable Polarization XUV Beamline P04 provides XUV radiation in the photon energy range from 250 to 3000 eV. Due to the low emittance of the storage ring of 1 nmrad and the 5m APPLE-II-type undulator installed at beamline P04, the radiation is of very high quality in terms of brightness and coherence. In order to exploit these possibilities a

---

\*Principal corresponding author

\*\*Corresponding author

*Email addresses:* [jens.viefhaus@desy.de](mailto:jens.viefhaus@desy.de) (Jens Viefhaus),  
[frank.siewert@helmholtz-berlin.de](mailto:frank.siewert@helmholtz-berlin.de) (Frank Siewert)

selection of scientific fields and techniques has been identified in the planning stage of the PETRA III project. The selection contains:

- Gas phase studies
- Soft x-ray scattering
- Magnetic spectroscopy
- High-resolution photoelectron spectroscopy
- Surface chemistry
- Spectro-microscopy

In order to achieve the associated scientific goals certain beamline specifications have been defined during a number of user workshops. The required specifications are:

- Photon energy range: (<100) 250 - 3000 eV
- Resolving power:  $> 10^4$  (up to  $> 3 \times 10^4$  @ 1 keV)
- Photon flux:  $> 10^{12}$  photon/s (up to  $5 \times 10^{12}$  photons/s)
- Spot size at sample:  $10 \times 10 \mu\text{m}^2 / 50 \times 50 \mu\text{m}^2$
- Polarization: circular, linear (hor./vert.) (<0.1 Hz switching rate)

## 2. Beamline design

The combination of all these parameters are quite unique for a XUV beamline, therefore we had to adopt the optical design given in figure 1 especially to be able to cover the large range of photon energies. As there is no standard coating material available which has no absorption edge in this photon energy range we had to use at least two coatings on the optical elements. This in turn favored the use of plane optical elements in order to use a simple translation for a change of the coating without the need for re-alignment. As the divergence and also the vertical source size is already diffraction limited in the full energy range one can use the un-collimated beam up to the focusing optics in front of the experiment. Therefore the first two optical elements can be plane mirrors.

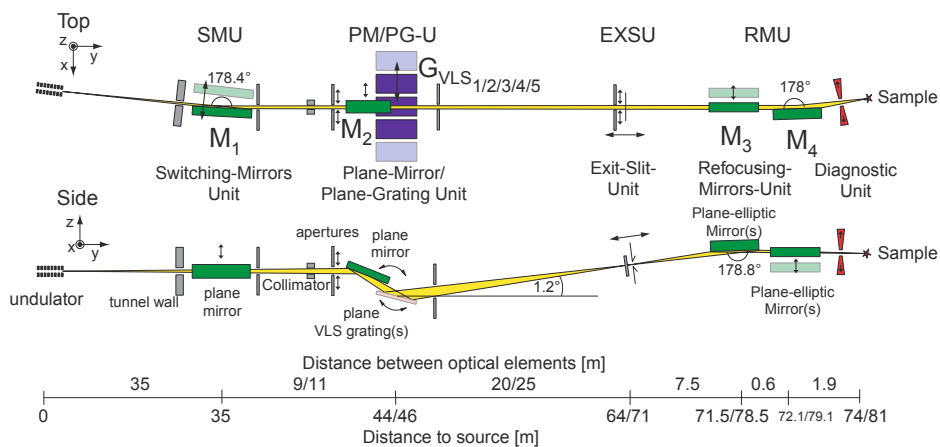

Figure 1: Schematic layout of the Variable Polarization XUV Beamline P04 at PETRA III. The main opto-mechanical components are labeled. This includes the switching mirrors unit (SMU) which distributes the radiation in one of the two branch lines. As a consequence of this all following components have to be realized twice: the plane-mirror/plane-grating-units (PM/PG-U), the exit slit units (EXSU) as well as the refocusing mirrors units (RMU). Both RMU can operate two sets of fixed KB-focusing mirror pairs each having two different foci. All optical elements have to be translatable in order to access the two different coatings (Au/Pt or Rh, respectively) required to cover the full range of photon energies.

Mirror  $M_1$  is situated inside the switching mirrors unit (SMU) which allows to serve two branch lines of the beamline P04 enabling a fast switching between two independent experiments. As this mirror has to withstand a rather high power of up to 1.5 kW (at 100 mA storage ring current) power(density)-[2, 3] and FEM-calculations showed that only internal  $\text{LN}_2$  cooling keeps the deformations due to the heat load within acceptable limits. In contrast to this internal water cooling was found to be sufficient for mirror  $M_2$  which is the pre-mirror in front of the grating and is expected to absorb more than one order of magnitude less power (up to 48 at 100 mA). Focusing onto the exit slit is performed by a varied line-space (VLS) plane grating. Due to the long exit arm length only a modest variation of the line density is required. The focusing at the exit slit remains at a constant position if the so-called fixed focus constant  $c_{ff}$  is varied accordingly with varying photon energy [4]. A further modification of the  $c_{ff}$  parameter could allow to compensate changes of the optics due to thermal deformation [5]. In any case this constant is fully determined for a particular grating and different modes of operation e.g. normal vs. high resolution can only be obtained with different gratings. To allow for different modes of operation up to five gratings ( $G_{1-5}$ ) can be installed in the plane-mirror/plane grating-unit (PM/PG-U). Focusing onto the different sample areas is performed via two different pairs of mirrors ( $M_3$  and  $M_4$ ) having a fixed shape in Kirkpatrick-Baez(KB)-geometry [6] in order to achieve simultaneously a vertical and horizontal focus at the given sample plane.

### 3. Mechanics

The anticipated beamline properties impose also very stringent stability requirements on the mechanics of the optics as well as the overall stability of the facility. The latter one is based on a 1 m thick concrete foundation covering the entire floor of the experimental hall 280 m in length and 24 m in width [7]. In this way both the storage ring section including the undulators as well as all beamlines are based on the same single piece of concrete resulting in a damping of the vibrations due to cultural noise by one order of magnitude [8].

The mechanics which are placed inside ultra-high-vacuum vessels have been designed for high accuracy and stability of the required movements. All mechanics have been thoroughly tested prior, during and after the installation. In all cases the required specifications have been met. As an

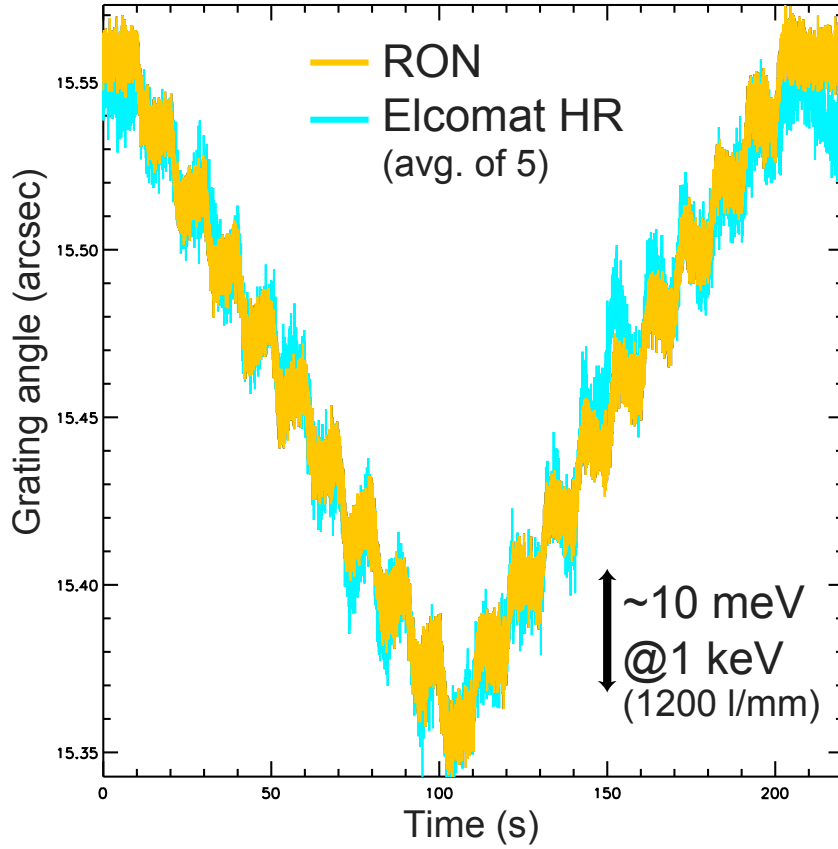

Figure 2: Mechanical performance of the rotational movement of the grating inside the PM/PG-U vessel of beamline P04. The curves showing the internally (RON) as well as externally (Elcomat HR) measured rotation are obtained by a stepwise rotation of the grating. Each step corresponds to 0.02 arcsec with an interval of 10 s between each consecutive step. An arrow indicates the corresponding rotation of the 1200 l/mm grating for a 10 meV energy step at 1 keV photon energy.

example the mechanical performance of the plane-mirror/plane-grating unit (PM/PG-U) is shown in figure 2 for the case of the rotational movement of the plane grating. The measurement is performed simultaneously by the internal in-vacuum angular measuring system (Heidenhain RON 905 UHV, interpolated resolution 0.002 arcsec) which is also used for the closed-loop control as well as an external measurement using an autocollimator outside of the vacuum (Elcomat HR, noise floor 0.004 arcsec, 0.01 arcsec specified accuracy). The results in figure 2 show clearly resolved steps of 0.02 arcsec which are necessary in order to utilize the specified resolution of the beamline P04. Because of the fact that the external device is fixed to the base of the PM/PG-U with an aluminum frame support, certain influences from external vibrations can not be completely ruled out. Therefore more precise measurements with sub-0.01-arcsec steps - which are at the limits of the present setup in ideal situations during the night at weekends - would have to use a different setup, e.g. using in vacuum interferometers. Nevertheless the overall results of the mechanics test were quite satisfactory. For the exit-slit unit (EXSU) having an vertical exit slit opening of 0-2000  $\mu\text{m}$  we verified a repeatability of the slit setting in the order of 100 nm in the range up to 100  $\mu\text{m}$  and less than 1% deviation above. The refocusing mirrors units based on two out-of-vacuum hexapods for each of the KB-mirrors showed a stability of the mirror movement better than 1  $\mu\text{m}$  and an angular precision in the order of 1  $\mu\text{rad}$  which can be further improved down to about 0.1  $\mu\text{rad}$  for the case of the two pitch angles of the mirrors  $M_3$  and  $M_4$  using in-vacuum piezo-actuators. In all cases it turned out to be necessary that all of the mechanics are inside a separate climatization hutch which is controlled to a temperature stability of less than 0.1°C which is an order of magnitude better than the experimental hall at PETRA III.

#### 4. Optics

For achieving the beamline performance correspondingly high quality optics at the limit of present technology have to be obtained. This is both a challenge for the manufacturer as well as quality control. All optics have been characterized at the BESSY II Optics Laboratory of the Helmholtz Zentrum Berlin using the nanometer optical component measuring machine (NOM) for shape measurements [9] as well as an AFM for roughness determination. A collection of the results obtained so far together with the required specifications is presented in table 1. The results show that in all cases the

specifications have been met.

Table 1: Properties of the P04 optics

Item	Size	Figure	Roughness	( $\sigma$ in nm)	Slope error	( $\sigma$ in arcsec)
	(l×w×h, mm)		Specs	Measured	Specs	Measured
M <sub>1</sub>	400×60×60	plane	0.5		0.1	0.06
M <sub>2</sub>	560×60×60	plane	0.5		0.05	
G <sub>1</sub>	145×32×23	plane	0.5	0.3-0.4	0.05	0.037
G <sub>2</sub>	130×32×23	plane	0.5	0.5-0.7	0.05	0.024
M <sub>3b1</sub>	500×30×60	plane-ellipse	0.5	<0.1	0.2	0.2
M <sub>4b1</sub>	600×30×60	plane-ellipse	0.5		0.2	
M <sub>3b2</sub>	500×30×60	cylinder	0.5	0.1	0.2	0.09
M <sub>4b2</sub>	600×30×60	cylinder	0.5	0.1	0.2	0.13

For a detailed assessment however is necessary to check the expected performance based on ray-tracing calculations which had been used to derive the required optical performance a-priori. The calculations have been performed using the software package SHADOW/XOP [10] together with additional procedures developed to automatize repetitive tasks in order to calculate many different photon energies and taking into account mis-alignments. Using the surface data obtained by the metrology after the manufacturing process we obtained the results shown in figure 3. For those optics where we have not yet obtained the final data we have used the data of a similar piece of optics. The results are quite encouraging as they show that one can match or even exceed the required beamline performance.

At the time of writing beamline P04 is in operation with preliminary optics for the M<sub>1</sub> and M<sub>2</sub> mirror, therefore we can not have a final answer on the photon energy resolution. As only three of four KB-mirrors have been delivered yet we can also not give quantitative results on the obtained focus dimensions. However we can state that the photon flux as well as the overall stability of the beamline and its components is well in accordance with the specifications. As soon as the missing optics are delivered, characterized and installed we can expect that the intended science program will quickly take advantage of the unique set of photon properties offered by beamline P04 at PETRA III.

It is a pleasure to acknowledge the great support by the PETRA III team and all DESY-FS service groups and work shops. In addition we

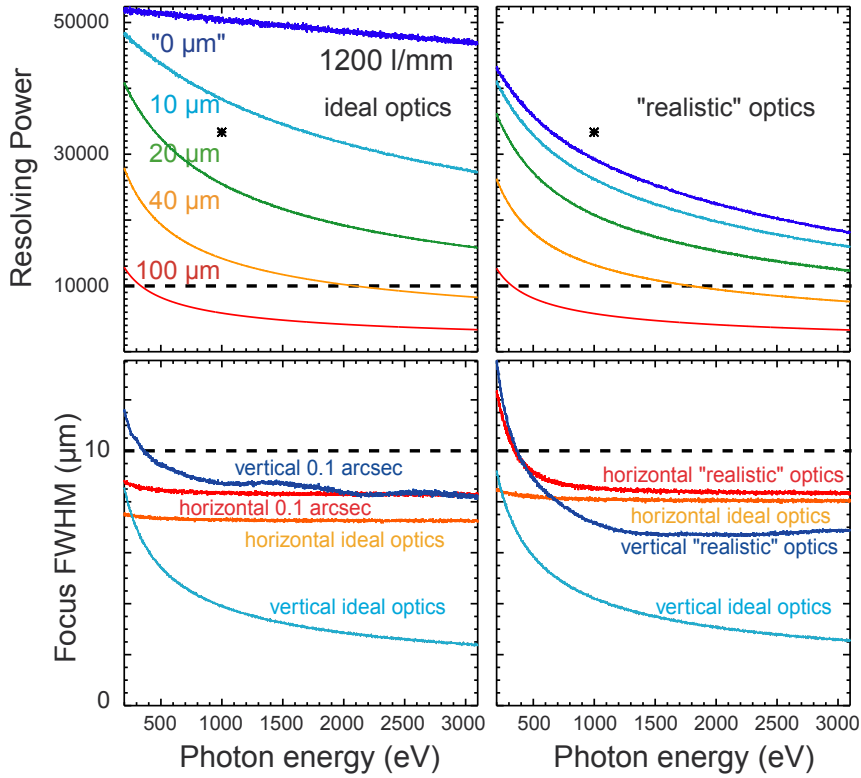

Figure 3: Expected resolving power (top) and focus size at the sample position (bottom) for beamline P04. The results on the left hand side are calculated for perfect optics whereas the results on the right hand side take into account the actually determined shapes of the optics. The dashed line indicates the requested performance by the user groups. The star in the resolving power plots indicates a photon energy resolution of 30 meV at a photon energy of 1 keV which represents a special user demand.



warmly thank Jana Buchheim for valuable assistance during the metrology process as well as the inspiring advice from the P04 review team consisting of Nick Brookes (ESRF), Rolf Follath (HZBerlin), Hermann Franz (DESY), Michael Martins (Uni Hamburg), Ruben Reininger (SAS), Fred Senf (HZBerlin), Edgar Weckert (DESY) and Wilfried Wurth (Uni Hamburg).

## References

- [1] H. Franz, O. Leupold, R. Röhlsberger, S. Roth, O. Seeck, J. Spengler, J. Strempler, M. Tischer, J. Viefhaus, E. Weckert, T. Wroblewski, *Synchrotron Radiation News* 19 (2006) 25–29.
- [2] T. Tanaka, H. Kitamura, *Journal of Synchrotron Radiation* 8 (2001) 1221–1228.
- [3] R. Reininger, SRcalc software (2005) v1.4.0.
- [4] R. Reininger, A. de Castro, *Nuclear Instruments & Methods in Physics Research Section A-Accelerators Spectrometers Detectors and Associated Equipment* 538 (2005) 760–770.
- [5] R. Reininger, K. Kriesel, S. L. Hulbert, C. Sanchez-Hanke, D. A. Arena, *Review of Scientific Instruments* 79 (2008) 033108.
- [6] P. Kirkpatrick, A. Baez, *Journal of the Optical Society of America* 38 (1948) 766–774.
- [7] H. Franz, L. Hänisch, J. Spengler, *HASYLAB annual report* (2006) 145–148.
- [8] J. Spengler, H. Franz, G. Wellenreuther, *11th International Conference on Synchrotron Radiation Instrumentation* (2012) TH–G–P–06.
- [9] F. Siewert, J. Buchheim, T. Hoeft, S. Fiedler, G. Bourenkov, M. Cianci, R. Signorato, *Measurement Science & Technology* 23 (2012) 074015.
- [10] M. S. del Rio, N. Canestrari, F. Jiang, F. Cerrina, *Journal of Synchrotron Radiation* 18 (2011) 708–716.