

# Enhancement of A Road Sign Board Using Wireless Sensors

Vaishali Gatty<sup>1</sup>, Mayuri Kadam<sup>2</sup>, Bhagyashree Dighe<sup>3</sup>

: MCA Department,

Vivekananda Education Society's Institute of Technology,  
Mumbai, India

vaishali.gatty@ves.ac.in, mayuri.kadam@ves.ac.in, bhagyashree.dighe@ves.ac.in

**Abstract:-** Road sign Detection and recognition is a real time system. It is also known as a Driver Assistant System(DAS) and it is one of the key technologies of Intelligent Transportation Systems (ITS). This System is being more and important with improving urban scale and increasing number of vehicles. Previous researches on this topic focus mainly on sign board detection with its color or shape.

In this work, we present results of an attempt to locating traffic signs with wireless sensor networks which is useful to the driver to provide information regarding the traffic rules, instructions and information given on the road at the time of driving irrespective of the weather condition or any obstacle which may make sign boards difficult to see for drivers.

**Key words—** Driver Assistant System , Intelligent Transportation, wireless sensor networks ,Road sign board, Sensor communication, Intelligent Processing, Sensor Data acquisition.

\*\*\*\*\*

## I. INTRODUCTION

In the absence of proper signboards, barricades and speed breakers driving requires extra caution. Any miscalculation on the part of the driver results in an accident.

Signboards alerting the drivers on diversions ahead have not been placed at several areas, which is the main reason for accidents, drivers feel.

Since the van driver took the wrong diversion due to non-availability of a signboard, it led him to the wrong lane that ultimately resulted in the accident and loss of lives.

Efforts are being given to improve the stability of the sign board system by introducing new technologies.

Intelligent Transport Systems (ITS) have great potential to save time, to save money, to save lives, and to improve our environment. [4]

ITS's have considerable potential to be a future commercial success. These systems are also closely linked to other major emerging technologies; the internet, mobile data services, smart sensors, artificial intelligence, position technologies, geographical information systems (GIS).

Road and traffic sign recognition is one of the important fields in the ITS. This is due to the importance of the road signs and traffic signals in daily life. They define a visual language that can be interpreted by the drivers. They represent the current traffic situation on the road, show the danger and difficulties around the drivers, give warnings to them, and help them with their navigation by providing useful information that makes the driving safe and convenient.

The concept of road sign board recognition is not very old; the first paper appeared in Japan in 1984. [6] The aim was to try various computer vision methods for the detection of objects in outdoor scenes.

Different techniques have been used, and big improvements have been achieved during the last decade.

The road sign boards are identified using image processing method by two main stages: detection, and recognition of images.

And the image processing is done by color and shape of sign boards But now in many cases shape of sign board may get damaged and not in a proper shape(eg: triangle) and color of that sign board may get blur because of many other reasons.

So this paper is to implement a new concept for sign board detection and recognition by using wireless sensor communication between vehicle and each sign board on a road.

## II. PROBLEM DEFINITION

Because of the complex environment of the roads and the scenes around them, road signs can be found in different conditions, and hence the detection and recognition of these signs may face one or more of the following difficulties. The colour of the sign fades with time as a result of the long exposure to the sun light, and the reaction of the paint with the pollutants in the air. [5]

The visibility of traffic signs is affected by the weather conditions like fog, rain, clouds and snow , and other parameters like local light variations such as the direction of light, the strength of the light depending on time of the day and season, and shadows generated by other objects(fig 1.1)



fg:1.1

Visibility is affected by the weather conditions such as the fog, rain, clouds and snow, as shown in Figure 1.2



fig1.2

Visibility can be affected by local light variations such as the direction of the light, the strength of the light depending on the time of the day and the season, and the shadows generated by other objects, Figure 1.3



fig :1.3

The presence of the obstacles in the scene, like trees, buildings, vehicles and pedestrians (fig:1.4).



fig:1.4

Signs may be found disoriented, damaged (Figure 3.7), or occluded by any kind of obstacles, even by some other signs(fig:1.5)



fig: 1.5

By above points explained it is extremely important for the algorithms to be developed for the detection and recognition of road and traffic signs to have high robustness of colour segmentation, high insensitivity to brightness variations, and should be invariant to geometrical effects such as translation, in-plane .

### III. WORKING OF PROPOSED SYSTEM

According to study of previous system there is a need of enhancement in detection of road sign boards to reduce road accidents. [3] Already there are some systems existing for purpose of image acquisition by color detection and shape detection. As we discussed previously to solve the problem of existing system we have come up with wireless sensor communication between sign boards and vehicles which will definitely overcome the problem of existing system.

In the proposed system both the vehicle and sign board should have sensor node which will communicate with each other to transfer the sign board data which indicates traffic signs to the vehicle irrespective of its condition in terms of color ,shape or may be damaged by any obstacle. [7]

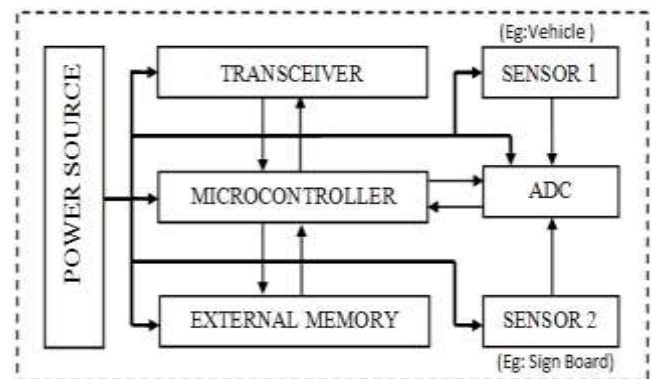

Total working of wireless sensor networking is based on its construction. Sensor network initially consists of small or large nodes called as sensor nodes. These nodes are varying in size and totally depend on the size because different sizes of sensor nodes work efficiently in different fields.

Wireless sensor networking have such sensor nodes which are specially designed in such a typical way that they have a microcontroller which controls the monitoring, a radio transceiver for generating radio waves, different type of wireless communicating devices and also equipped with an energy power source such as battery. [1]

The entire network worked simultaneously by using different dimensions of sensors and worked on the phenomenon of multi routing algorithm which is also termed as wireless ad hoc networking.

### IV . ALGORITHM FOR PROPOSED SYSTEM

- Step 1:  
Vehicle sensor detects Road sign board sensor to communicate.
- Step 2:  
Vehicle's sensor requests for sign data to the sensor attached with sign board .
- Step 3:

Signboard sensor returns the data constant to vehicle which is always a unique constant assigning particular sign.

Step 4 :

Each sign is assigned by a unique constant to recognized as shown in following table

<b>Take a right</b>	“1”
<b>Take a left</b>	“2”
<b>Speed Breaker</b>	“3”
<b>Go slow</b>	“4”
<b>Tunnel ahead</b>	“5”

Step 5:

Sensor at vehicle side once received data constant will now make a Intelligent Decision as shown in above table.

Step 6:

Now sensor with vehicle will pass the correct result showing message according to sign board instructions.

#### V. MECHANISM OF WSN COMMUNICATION FOR ENHANCED SYSTEM

Proposed mechanism consist of three steps as follows

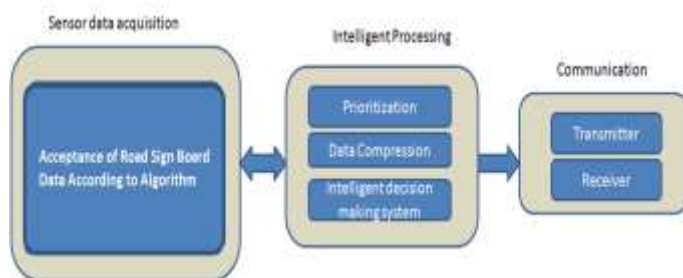

- a) Communication
- b) Intelligent Processing
- c) Sensor Data acquisition

#### Communication:

- A transmitter (or radio transmitter) is an electronic device which produces radio waves with the help of an antenna. A transmitter generates a radio frequency current applied to the antenna, which in turn radiates radio waves.
- In this mechanism, Transmitter can road sign board data signal.
- The receiver will detect the signal using a Radio receiver sensor that is tuned to detect that frequency and turn the vehicle message on.

#### Intelligent Processing :

- Prioritization deals with selection of the particular transmitter of the current wireless network and avoiding interference of other sensor nodes which are not participated in current networks.

- Wireless sensor networks (WSNs) are resource constraint: limited power supply, bandwidth for communication, processing speed, and memory space. One possible way of achieve maximum utilization of those resource is applying data compression on sensor data. Usually, processing data consumes much less power than transmitting data in wireless medium, so it is effective to apply data compression before transmitting data for reducing total power consumption by a sensor node. [2].
- Each wireless network works on basic algorithm or a set of instructions which is its intelligent decision making system. In this case recognizing or identifying road sign on the basis of data constant received from transmitter

#### Sensor data acquisition:

- Intelligent Decision making results into final message passed to person controlling the vehicle this procedure is sensor data acquisition. In this case sensor at vehicle side with final decision converts the data constant into instruction of the sign board and passes to the vehicle driver

#### VI. ADVANTAGES OF ENHANCED SYSTEM

- In any weather condition like rain or fog if driver is unable to see sign board then also sensor will pass instruction to the driver according to road conditions.
- Due to any reason if color or shape of sign board gets damaged in this case also sensor will pass instruction to the driver according to road conditions.
- If sign board gets hide due to any obstacles (eg: trees) in this case sensor can communicate with vehicle and direct the driver.
- If visibility of sign board is affected by local light variations such as the direction of the light, the strength of the light depending on the time of the day and the season, and the shadows generated by other objects then also sensors are useful to direct the driver.
- This mechanism reduces the average rate of road accidents due to bad conditions of sign board.

#### VII. CONCLUSION

Hence it concludes that instead of using the existing mechanism (Which includes traditional road sign boards and leads to road accidents ) now we can use the newly proposed system which has many advantages (As stated) over the existing system.

#### VIII. REFERENCES

- [1] [https://books.google.co.in/books?id=3ad7AAAAQBAJ&pg=PA65&lpg=PA65&dq=how+two+sensors+communicate+with+each+other&source=bl&ots=HJZ4ln5\\_qr&sig=MIUIGzqa7KivMXrgIjGP6DczVvs&hl=en&sa=X&ei=mCpBVfjcD4PmuQSBY4HYCg&ved=0CEwQ6AEwBg#v=onepage&q=how%20two%20sensors%20communicate%20with%20each%20other&f=false](https://books.google.co.in/books?id=3ad7AAAAQBAJ&pg=PA65&lpg=PA65&dq=how+two+sensors+communicate+with+each+other&source=bl&ots=HJZ4ln5_qr&sig=MIUIGzqa7KivMXrgIjGP6DczVvs&hl=en&sa=X&ei=mCpBVfjcD4PmuQSBY4HYCg&ved=0CEwQ6AEwBg#v=onepage&q=how%20two%20sensors%20communicate%20with%20each%20other&f=false)

- 
- [2] Kimura, N. ; Dept. of Electr. & Comput. Eng., Nevada Univ., Las Vegas, NV, USA ; Latifi, S. "A survey on data compression in wireless sensor networks".
  - [3] W.K.I.L. Wanniarachchi , D.U.J. Sonnadara and M.K. Jayananda (Department of Science and Technology, Uva Wellassa University, Badulla, Department of Physics, University of Colombo)“ Detection and Extraction of Road Traffic Signs”
  - [4] Hisaka, S. ; Inst. of Ind. Sci., Univ. of Tokyo, Tokyo, Japan ; Kamijo, S. “On-board wireless sensor for collision avoidance: Vehicle and pedestrian detection at intersection” [5]
  - [5] Hasan FLEYEH , Mark DOUGHERTY “ROAD AND TRAFFIC SIGN DETECTION AND RECOGNITION”
  - [6] M. Lalonde and Y. Li, "Road sign recognition. Technical report, Center de recherché informatique de Montréal, Survey of the state of Art for sub-Project 2.4, CRIM/IIT,"1995.
  - [7] S. Lu, "Recognition of traffic signs using a multilayer neural network," presented at 1994 Canadian Conf. Electrical and Computer Engineering, Halifax, NS, Canada,1994.