

Stress Analysis of Bell Crank Lever

Mr. M. M. Dange^{*1}

^{*}Pg. student of Department of
Mechanical Engineering
R.C.E.R.T. Chandrapur, India
¹dangemilind@rediffmail.com

Prof. S. R. Zaveri^{**2}

^{**}Associate Professor Department of
Mechanical Engineering
R.C.E.R.T. Chandrapur, India
²srzaveri53@rediffmail.com

Prof.S.D.Khamankar^{***3}

^{***}Associate Professor Department of
Mechanical Engineering
R.C.E.R.T. Chandrapur, India
³sdkhamankar@gmail.com

Abstract - Bell Crank Lever is important components from safety point of view since they are subjected to large amount of stresses. Hence to study the stress pattern in bell crank lever, analytical, numerical and photoelasticity methods are used. For analysis purpose virtual model of bell crank lever is prepared by picking data from design data book. Bending stresses in lever formula is used for determination of stresses in bell crank lever analytically. For numerical analysis bell crank lever is prepared using ANSYS and this model of bell crank lever in ANSYS where stress analysis is done by FEM. Finite Element Analysis(FEA) have been performed on various models of varying fillet radius, optimization for volume and reduction of materials form bell crank lever and by using photoelasticity of bell crank lever. Also for bell crank lever stress analysis is done by using method of FEM. From the output of these analyses it is observed that results obtained are in close agreement with each other and maximum failures stress concentration occurs at maximum bending surface. Comparison between numerical, FEM and experimentally are observed that results obtained are in close agreement with each other.

Keywords: bell crank lever, bending Stresses in lever, FEA, Photo-elasticity.

I. INTRODUCTION

The most important task before design engineer is to maintain the working stresses within predetermined specific limits, in order to avoid the failure of a member. To improve the product quality, it is necessary to determine the stresses in various components. It is also necessary to know the stress distribution in order to predict the failure of component.

Bell crank lever is used to reduce a load by applying of a small effort. Bell crank lever is used in the machine to lift a load by the application of a small effort. In a bell crank lever load (W) and force (P) acts at right angles. The cross-section of the lever is obtained by considering the lever in bending.

II. INTRODUCTION TO PROBLEM, SCOPE AND METHODOLOGY

The objectives of the project include modelling and analysis of bell crank lever using software packages. Also analytical calculation of the induced stresses and comparing them with results obtained through software. So that we can suggest best method for analysis and best cross section for the bell crank lever.

The objectives of this study is to

- Analysis the bell crank lever using finite element method.
- Determine stresses on bell crank lever.
- Determine Stresses on bell Crank lever experimentally.
- Determine maximum failure occur in the bell Crank lever

METHODOLOGY

In this project work stress analyses of bell crank lever with varying fillet radius, optimization of volume, reducing materials of bell crank lever and for the safe working load 100N. Properties of material used for bell crank lever are given in Table 1.1.

Table1. Properties of material SAE 1030

Property	Symbol	Value
Modulus of Elasticity	E	2×10^5 MPa
Poisson's ratio	μ	0.30

III. ANALYTICAL ESTIMATION OF STRESSES

Length of lever in mm.(FB) = 210 mm ;
Load applied on the lever (W) = 100 N ;
Length of lever in mm (FA) = 70 mm ;
Tensile stress of lever, in N/mm² (σ) = 75 M Pa
= 75 N/mm² ;
Shear stress of lever, in N/mm² (τ) = 60 Mpa
= 60 N/mm² ;

Calculate the effort (P) required to raise the load (W)100 N.

Taking moments about the fulcrum (F)

$$W \times 210 = P \times 70$$

$$100 \times 210 = P \times 70$$

$$\therefore P = 300 \text{ N}$$

Reaction at the fulcrum at F,

$$R_F = (W^2 + P^2)$$

$$= 316.22 \text{ N}$$

1. Design of fulcrum

Let d = Diameter of the fulcrum.

And l = Length of the fulcrum.

The bending stress induced in the lever arm at the fulcrum.

$$M = W \times FB$$

$$= 100 \times 210$$

$$= 21000 \text{ N-mm}$$

Section modulus (Z)

$$Z = 1/6 \times t \times b^2$$

$$= 1/6 \times 6 \times 18^2$$

$$= 324 \text{ mm}^3$$

∴ Bending stress,

$$fb = M/Z$$

$$= 21000/324$$

$$= 64.81 \text{ N/mm}^2$$

2. Stress on effort arm

Let t = Thickness of the lever at X-X, and

b = Width or depth of the lever at X-X.

Maximum bending moment at X-X,

$$= 100(210 - 18)$$

$$= 19200 \text{ N-mm}$$

and section modulus,

$$Z = (t \times b^2)/6$$

$$= t(3t \times t)/6 = 1.5 t^3 \dots (\text{Assuming } b = 3 t)$$

We know that the bending stress (fb),

$$Fb = M/Z$$

$$= 19200/324$$

$$= 59.25 \text{ N/mm}^2$$

3. Stress on load arm

Let t = Thickness of the lever at Y-Y, and

b = Width or depth of the lever at Y-Y.

Taking distance from the centre of the fulcrum to Y-Y as 18 mm, therefore maximum bending moment at Y-Y,

$$= 300(70 - 18)$$

$$= 15600 \text{ N-mm}$$

and section modulus,

$$Z = (t \times b^2)/6$$

$$= t(3t \times t)/6 = 1.5 t^3 \dots (\text{Assuming } b = 3 t)$$

We know that the bending stress (fb),

$$Fb = M/Z$$

$$= 15600/324$$

$$= 48.14 \text{ N/mm}^2$$

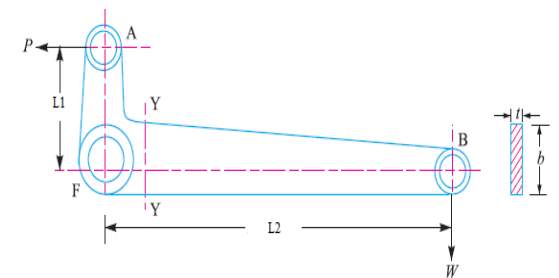

Figure1- Bell Crank Lever

Table No. 2 - Analytical Calculation for Volume Optimization of Bell Crank Lever.

Sr. No	Volume Optimization	Section of modulus (mm ³)	Maximum Principal Stresses $Fb = M/Z$ (MPa)
1	Shape-1	$Z_1=324$	$Fb_1=100(210-18)/324=59.25$
2	Shape-2	$Z_1=324$	$Fb_1=100(140-18)/324=37.65$
		$Z_2=196$	$Fb_2=100(70-18)/196=26.53$
3	Shape-3	$Z_1=324$	$Fb_1=100(70-18)/324=16.04$
		$Z_2=256$	$Fb_2=100(70-18)/256=20.31$
		$Z_3=196$	$Fb_3=100(70-18)/196=26.51$

Table 3 - Analytical Calculation of Bell Crank Lever Removing Number of Hole.

Sr. No.	Removing Number of Hole	Section of modulus (mm ³)	Maximum Principal Stresses $Fb = M/Z$ (MPa)
1	Original Shape	$Z=324$	$100(210-18)/324 = 59.25$
2	1 Hole	$Z=12.26$	$100(140-18)/(324-12.26) = 37.65$
3	2 Holes	$Z=24.56$	$100(140-18)/(324-24.56) = 64.11$
4	3 Holes	$Z=36.78$	$100(140-18)/(324-36.78) = 66.84$
5	Longitudinal Groove	$Z=71.96$	$100(140-18)/(324-71.96) = 71.96$

Table No. 4- Analytical Calculation of Bell Crank Lever by Applying Forces.

Sr. no.	Force (N)	Bending stresses (N/mm ²)
1	10	$10(210-18)/324=5.92$
2	15	$15(210-18)/324=8.88$
3	20	$20(210-18)/324=11.85$
4	25	$25(210-18)/324=14.81$

4. Preparation of ANSYS Model of bell crank lever

A model of a bell crank lever is prepared by using ANSYS software as per the dimensions. Some features are approximated for simplification ANSYS software is used for creating solid model of bell crank lever. Complete Solid ANSYS model is prepared which is shown in fig. 2 similarly for all required cross section solid ANSYS model is generated.

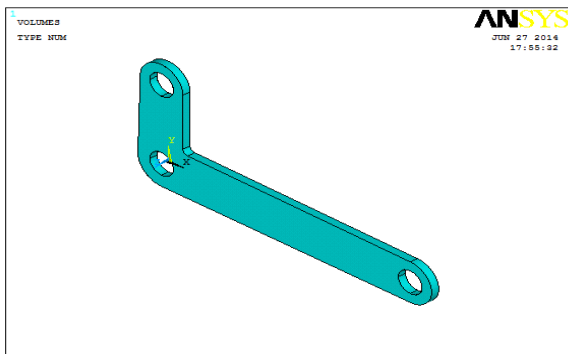

Figure2-ANSYS Model of Bell Crank Lever.

V. STRESS ANALYSIS USING FEM

The solid bell crank lever model is prepared in ANSYS for FEA. A structural 20 node Tetrahedral Solid 186 element is selected for creating FE model of the bell crank lever. Material properties as shown in table 1 are assigned and model is meshed using free meshing and smart size option. The FE model created is shown in fig.3.

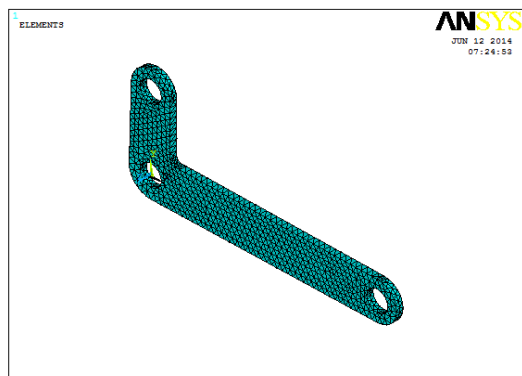

Figure3-Finite Element Model of Bell Crank Lever

For imposing boundary condition all degrees of freedom are restricted at the top end of load arm and the force of 100 N is applied on effort arm of nodes at lower centre of arm in downward direction. Then model is submitted to the ANSYS solver where it is solved. This is called as solution phase. Then results are presented by general post processor in graphical as well as table format. The pattern of first principal stress distribution in bell crank lever is shown in figure 4.

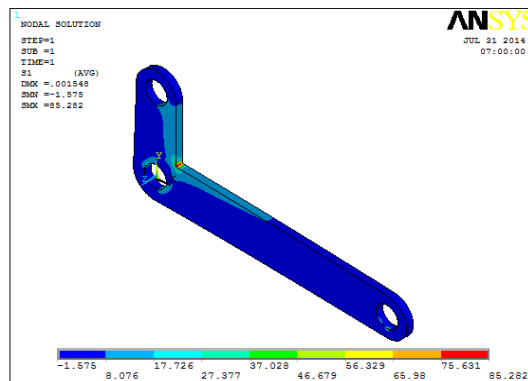

Figure4 - 1st Principal Stress of Bell Crank Lever with Fillet Radius 2 mm.

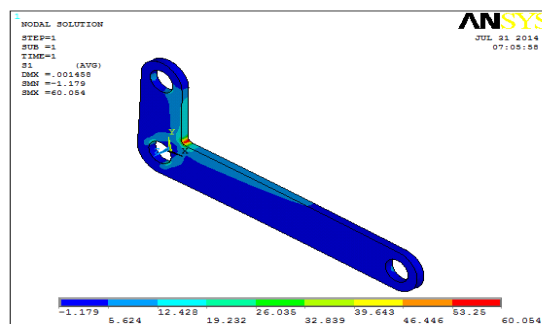

Figure5.- 1st Principal Stress of Bell Crank Lever with Fillet Radius 4 mm.

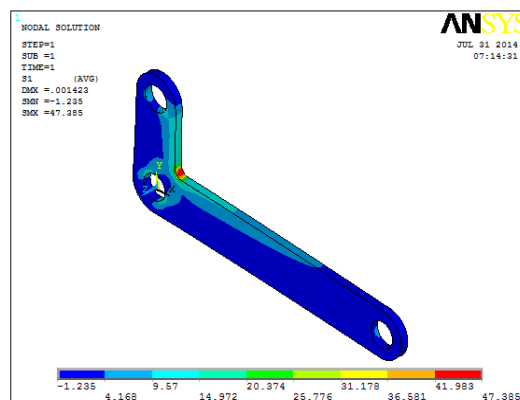

Figure 6 - 1st Principal Stress of Bell Crank Lever with Fillet Radius 6 mm.

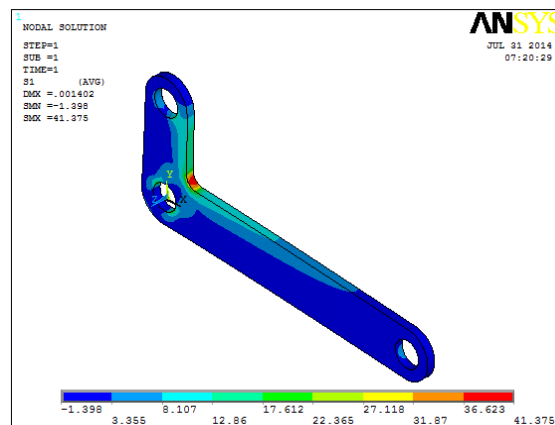

Figure 7 - 1st Principal Stress of Bell Crank Lever with Fillet Radius 8 mm.

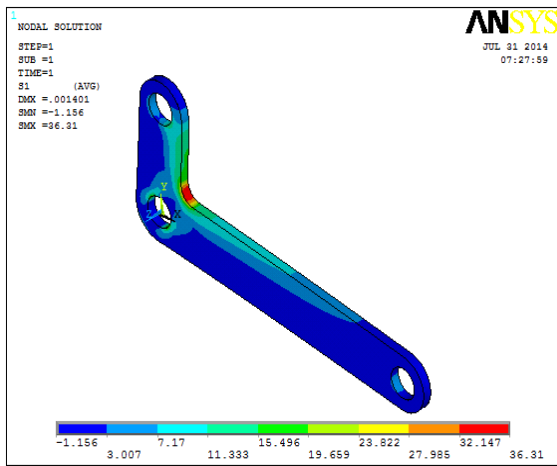

Figure8 - 1st Principal Stress of Bell Crank Lever with Fillet Radius 10 mm.

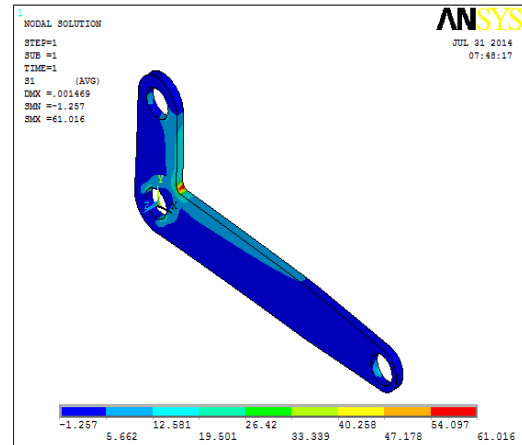

Figure 10 - 1st Principal Stress Optimization for Volume of Bell Crank Lever.

Table No.5- 1st Principal Stress of Bell Crank Lever with Varying Fillet Radius.

Sr. No.	Fillet Radius(mm)	Max. FE Stress (MPa)	Corresponding Fig.
1	2	85.28	Fig.4
2	4	60.05	Fig.5
3	6	47.38	Fig.6
4	8	41.37	Fig.7
5	10	36.31	Fig.8

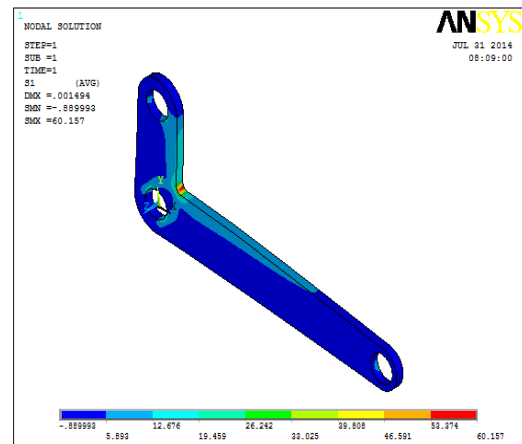

Figure11- 1st Principal Stress Optimization for Volume of Bell Crank Lever.

Table No. 6 - 1st Principal Stress Optimization for Volume of Bell Crank Lever.

Sr. No.	Volume Optimazati on	Max. FE Stress (MPa)	Corresponding Fig.
1	SHAPE 1	60.05	Fig.9
2	SHAPE 2	61.01	Fig.10
3	SHAPE 3	60.15	Fig.11

CASE-II

FEM STRESS ANALYSIS FOR VOLUME OPTIMAZATION OF BELL CRANK LEVER.

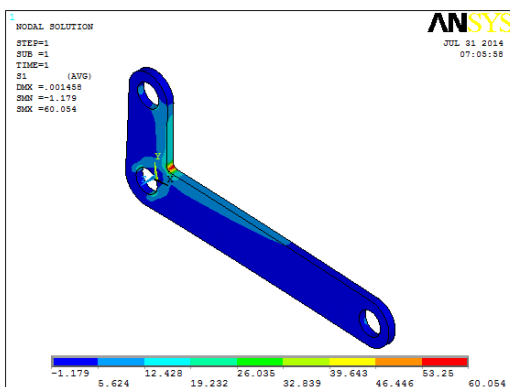

Figure9 - 1st Principal Stress Optimization Volume of Bell Crank Lever.

CASE –III

FEM Stress Analysis of Increasing Number of Holes in Bell Crank Lever.

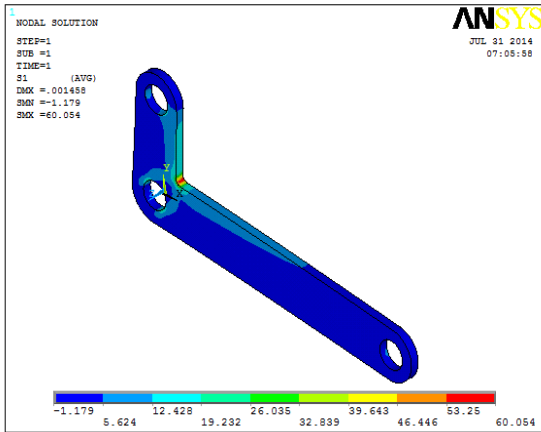

Figure 12- 1st Principal Stresses of Bell Crank Lever.

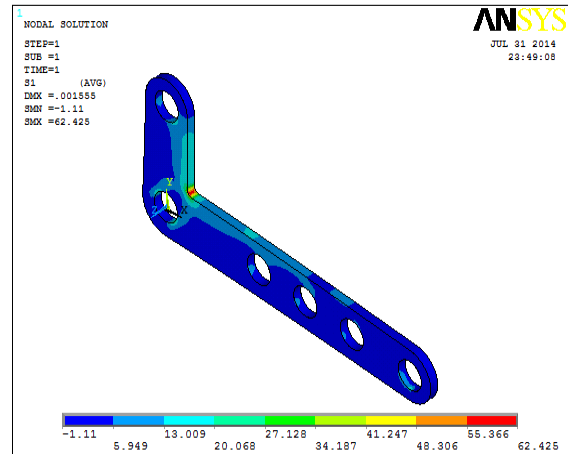
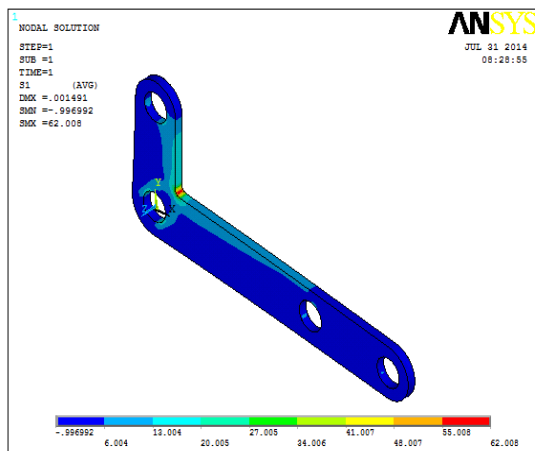

Fig. 15- 1st Principal Stresses of Bell Crank Lever Increasing 3 Holes.



1st Principal Stresses of Bell Crank Lever Increasing 1 Hole.

Figure13 -

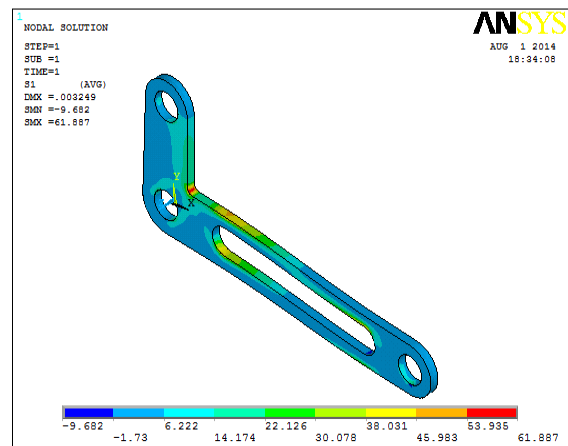
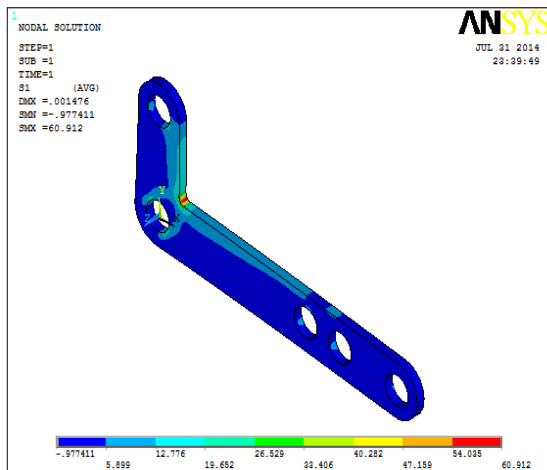

Figure16 - 1st Principal Stresses of Bell Crank Lever Removing longitudinal groove Material.



- 1st Principal Stresses of Bell Crank Lever Increasing 2 Holes.

Figure14

Table No. 7 - 1st Principal Stresses Increasing number of Holes.

Sr. No.	Max. FE Stress (MPa)	Corresponding Fig.
1	60.05	Fig.12
2	62.00	Fig.13
3	60.91	Fig.14
4	62.42	Fig.15
5	61.88	Fig.16

VI. STRESS ANALYSIS OF BELL CRANK LEVER USING PHOTOELASTICITY

For the verification of the results obtained from FEM, the experimentation is conducted using photoelasticity. Photoelastic model of bell crank lever is prepared from 6 mm thick sheet casted from epoxy resin (mixture of Araldite CY 230 and hardener HY951). Also circular shaped disc (calibration disc) of 65 mm diameter is prepared from the same sheet. Calibration of disc is done to find material fringe value, F_{σ} . This disc is taken and subjected to compressive load in the circular Polariscope setup as shown in fig.17.

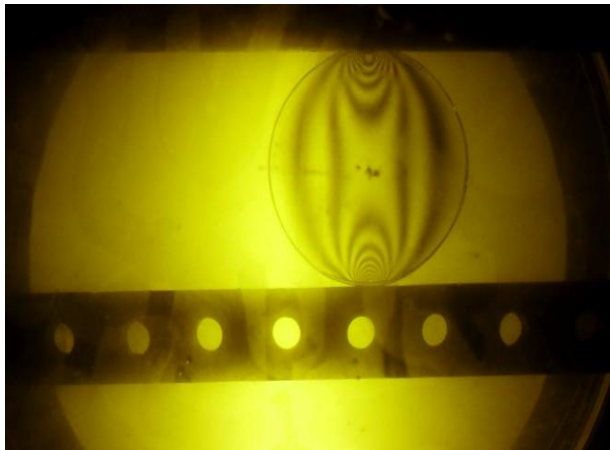

Figure.17. Isochromatic fringe pattern developed in circular disc under compression

Values of fringe order are noted down for different loads as shown in table 2. Using formula $F_{\sigma} = 8P/\pi DN$, material fringe value is determined and average is taken as 13.51 N/mm. where P=Load in N, N= Fringe order and D= diameter of disc=65 mm.

Table No. 8- Determination of material fringe value

S N	Load (N)	Fringe order			Fringe Value(F_{σ})		Avg. (F_{σ})
		Low er	Hig her	Avg .	F_{σ}		
1	7	0.64	0.72	0.68	13.00	13.51 N/mm	
2	8	0.73	0.81	0.77	13.18		
3	9	0.83	0.87	0.85	13.48		
4	10	0.91	0.93	0.92	13.65		
5	11	0.99	1.01	1.00	13.82		
6	12	1.07	1.11	1.09	13.96		

Isochromatic fringe pattern developed in photoelastic model of bell crank lever is shown in fig.18. Readings are taken for various loading conditions as depicted and stresses are determined using formula, $\sigma = NF_{\sigma}/h$.



Figure18. Isochromatic fringe pattern developed in photoelastic model of bell crank lever

Table 9. Readings for Determination of Stresses using photoelasticity

S N	Load (kg)	Fringe Order , N			Avg	$\sigma =$ NF σ /h (MPa)
		Lower Order	Higher Order			
1	1	2.5+0.15 =2.65	3.5-0.99 =2.51	2.58	5.80	
2	1.5	3.5+0.92 =4.42	4.5-0.28 =4.22	4.03	4.03	
3	2.0	5.5+0.05 =5.55	5.5-0.03 =5.47	5.39	12.12	
4	2.5	6.5+0.26 =6.76	6.5-0.13 =6.37	6.56	14.76	

CASE-IV-

FEM Stresses at Various Load Condition of Bell Crank Lever.

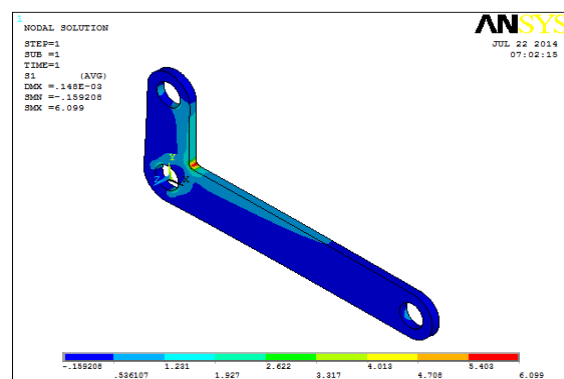

Figure. 19 - 1st Principal Stresses of Bell Crank Lever by Applying 10 N.

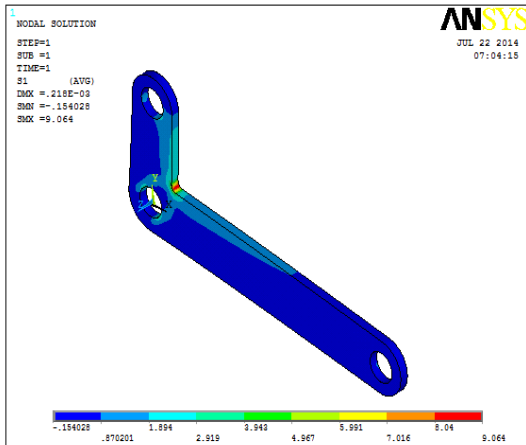

Figure20 - 1st Principal Stresses of Bell Crank Lever by Applying 15 N.

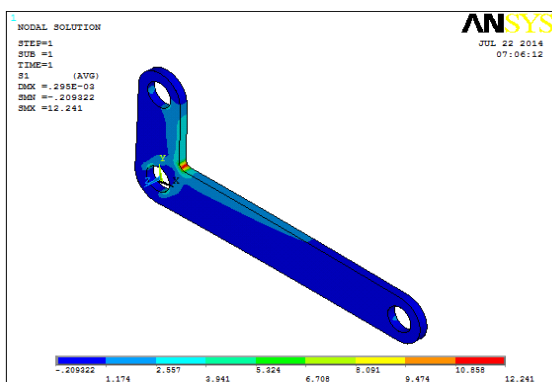

Figure21 - 1st Principal Stresses of Bell Crank Lever by Applying 20 N.

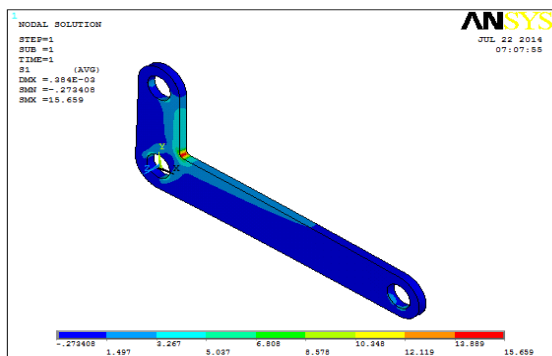

Figure22 - 1st Principal Stresses of Bell Crank Lever by Applying 25 N.

Table No. 10 - FEM Stresses at Various Force Condition of Bell Crank Lever.

Sr. No.	Force (N)	Max. FE Stress (MPa)	Corresponding Fig.
1	10	6.09	Fig.-19
2	15	9.06	Fig.-20
3	20	12.24	Fig.-21
4	25	15.69	Fig.-21

VII. RESULT & DISCUSSIONS

Table No.11- 1st Principal Stress of Bell Crank Lever with Varying Fillet Radius.

Sr. No.	Fillet Radius(mm)	Max. FE Stress (MPa)	Corresponding Fig.
1	2	85.28	Fig.4
2	4	60.05	Fig.5
3	6	47.38	Fig.6
4	8	41.37	Fig.7
5	10	36.31	Fig.8

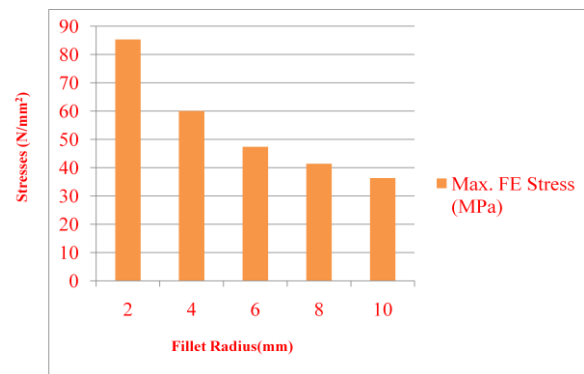

Figure23- Max. Stresses of Varying Fillet Radius.

Table No.12- FEM Stress Analysis for Optimising Volume of Bell Crank Lever.

Sr. No.	Volume Optimisation	Analytical Stresses	Max. FE Stresses	% Error
1	Fig.9	59.25	60.05	1.33
2	Fig.10	64.18	61.01	4.93
3	Fig.11	62.86	60.15	4.31

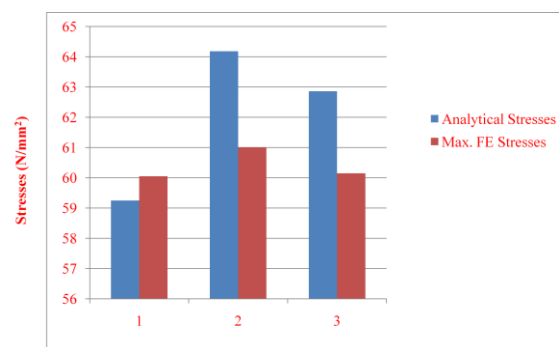

Figure.24-FEM Stress Analysis of volume Optimization

Table No.13 -FEM Stress Analysis of Increasing Number of Holes in Bell Crank Lever.

Sr. No.	Analytical Stresses	Max. FE stresses	Fig. No.
1	59.25	60.05	Fig.12
2	61.58	62.00	Fig.13
3	64.11	60.91	Fig.14
4	66.84	62.42	Fig.15
5	69.63	61.88	Fig.16

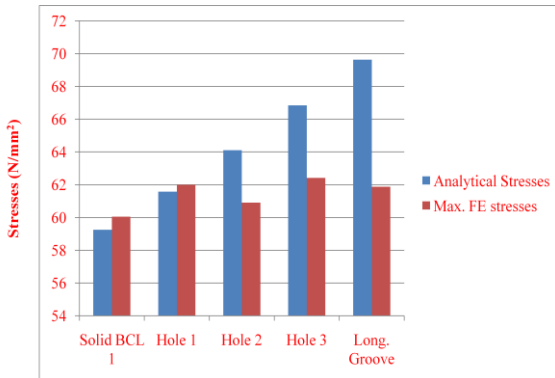

Figure.25- FEM Stress Analysis of Increasing Number of Holes.

Table No.14 - Comparison Between Analytical, FEM And Photoelasticity Results

Sr. No.	Force (N)	Analytical Stress (MPa)	FEM Stresses (MPa)	Experimental Stresses (MPa)
1	10	5.92	6.09	5.80
2	15	8.88	9.06	9.06
3	20	11.85	12.24	12.12
4	25	14.81	15.69	14.76

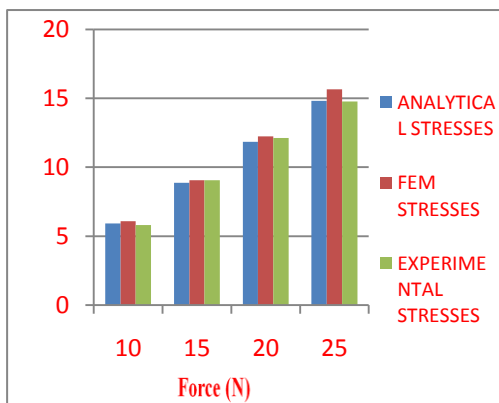

Figure26 - Comparison of Maximum Stresses Analysis by Analytical, FEM and Photoelasticity of Bell Crank Lever.

VIII. CONCLUSION

From the above results it is concluded that the maximum stress evaluated in bell crank lever increasing fillet radius at critical position than decrease maximum bending stresses as shown in fig. 5.3, 5.4, 5.5, 5.6 and 5.7.

For optimising the volume of bell crank lever, the volume is reduced by changing the shape of effort arm as shown in fig. 5.8, 5.9, 5.10 as well as increasing the number of holes as shown in fig. 5.11, 5.12, 5.13, 5.14 and 5.15. In effort arm it is observed that though the volume is reduce the maximum principal stresses at the corner of bell crank lever remains nearly constant and it is found to be equal to that of stresses in original model of bell crank lever.

Comparison between results obtained by analytically, FEM and photoelasticity reveals that they are in close harmony with each other with minimum percentage of error. Comparison between results obtained by analytically, FEM and photoelasticity are graphically shown in fig. 26.

REFERENCES

- [1]. Muhammad sahal bin zainol abidin-universiti teknikal,malaysia May-20011“Design and development of a bell crank for monoshock front suspension for formula varsity race car”.
- [2]. R. C. Patel, S.S. Sikh, H.G. Rajput (1992-93) “ Machine Design”
- [3]. J.grigoniene* a.masiulis† klaipeda university 19-25 june, 2012. “Non dimensional analysis of a crank-slide-block mechanism”.
- [4]. S. D. Shelare, P. S. Thakare, Dr. C.C. Handa international journal of scientific & technology research volume 1, issue 5, june 2012 “Computer Aided Modeling”.
- [5]. Anjali S.Joshi and Dr. Jayant V. Modak, Volume : 3 | Issue : 2 | February 2013 | ISSN - 2249-555X. “Design and development of a Small Capacity Stone Crusher Mechanism”
- [6]. Kelly Sandoval (2004). “Purposes and Organization of a Collaborative Design-Based Research”.
- [7]. Lucas V. Fornace University of California, San Diego, 2006. “An Investigation in Topology Optimization Weight Reduction Techniques Applied to Formula Vehicle Design”IAS Design Data