

A Review: Analysis of White Space for Designing Communication Module

Miss. Shruti S. Kshirsagar

Department of Information Technology
T.G.P.C.E.T.
Nagpur, India
sshrutigk@gmail.com

Prof. Amit G. Fulsunge

Department of Information Technology
T.G.P.C.E.T.
Nagpur, India
amitgfulsunge@gmail.com

Abstract- In this paper we propose the literature review related to analysis of White Space for Designing Communication Module. The radio frequency spectrum is an essential factor in communication network. With demand for wireless connectivity increasing, the exploitation of white space is an attractive way of making more efficient use of radio spectrum. This paper is based on the detecting the unutilized spectrum that can safely be used for broadband communication networks.

Keywords- communication modules; UART; review; White spaces; wireless connectivity

I. INTRODUCTION

White Space is the common term used when referring to the reuse of the guard bands (white space) in the digital TV spectrum for the purpose of broadband networking. With demand for wireless connectivity increasing, the exploitation of white space is an attractive way of making more efficient use of radio spectrum. Now days, there is growing demand for bandwidth of broadband network. Thus reduce the anticipated strain on the network by taking advantage of underutilized spectrum, such as TV white space (TVWS) [2]. TV signals rarely occupy the full spectrum allocated to them. In many regions, the subsequent white space between channels could be used by other communications devices. This sensing devices support multimode operation that includes mobile communications, machine-to-machine (M2M), and Wi-Fi operations. The aim of this synopsis is to develop and demonstrate the real-time coding to detect unutilized spectrum which can be safely used for broadband communication. Also the focusing of project is on bandwidth aggregation and dynamic spectrum management of communication network [5].

A. Overview of "white spaces"

'White Spaces' are portions of radio spectrum which are not used by existing licensees at all times or in all locations. Figure 1 illustrates the concept, showing unused 'white spaces' between licensed transmissions [7]. With demand for wireless connectivity increasing, the exploitation of white space is an attractive way of making more efficient use of radio spectrum.

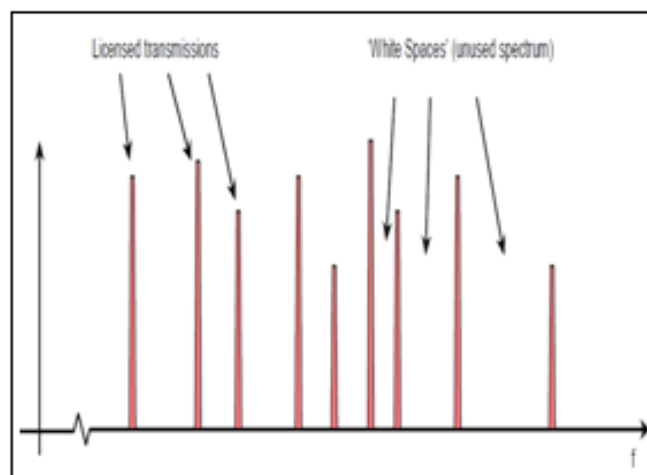

Figure 1: Graphic illustration of licensed transmissions at certain frequencies, with 'white spaces' between them.

In many countries, analogue television broadcasts are being switched off and replaced by more spectrally efficient digital television transmissions, and the white spaces that exist in the UHF TV band (470 MHz - 790 MHz in ITU Region 1) have good propagation and building penetration characteristics [1]. This potentially makes them suitable for use in rural broadband applications, where transmission links may be several kilometers in length and may involve challenging terrain such as hills, foliage, and water [6].

II. LITERATURE REVIEW

Sr. No	Name of Author	Paper Title	Publication	Approach & concept about Work	Advantages	Limitation of Work
1	Jihye Lee and Taehyun Jeon	FPGA Based Implementation of Gain Control Block for OFDM System	International Journal of Control and Automation Vol.7, No.2 (2014)	They implemented AGC with four different gain loops, the RTL level simulation is performed first. The design is carried out using the Verilog HDL. The resulting hardware design is compiled to fit into the FPGA hardware device. In their design Spartan 3E series FPGA device from Xilinx is used to test the functional operation at the physical hardware circuit level. With the chip design analysis tool the actual operation of the digital logic circuit can be also monitored and confirmed.	The proposed design is shown to provide the enhanced convergence speed and reduced processing time.	hardware complexity is increased marginally compared with the conventional system
2	Joseph Camp	White Space Networking with Wi-Fi like Connectivity	ACM SIGCOMM Computer Communication Volume 43, Number 5, October 2013	WhiteFi builds on a simple technique, called SIFT Algorithm that reduces the time to detect transmissions in variable channel width systems by analyzing raw signals in the time domain.	Speedily identification and measurement of locations, Manage traffic and disconnection.	WhiteFi does not use a static control channel.
3	Matthias John, Max Ammann	A Compact Shorted Printed Monopole Antenna for TV White Space Trials	European Conference on Antennas and Propagation - EuCAP, Gothenburg, Sweden, 08/04/2013	This paper presents a compact shorted printed monopole antenna with an omnidirectional radiation characteristic for use on spectrum-sensing software-defined-radio equipment in TVWS.	The antenna is demonstrated with good radiation performance and high efficiency.	Designed system limited only 470 MHz to 1050 MHz frequency band
4	Xuhang Ying, Jincheng Zhang, Lichao Yan	Exploring Indoor White Spaces in Metropolises	International Conference, MobiCom'13, Miami, FL, USA. 30 September – 4 October 2013	They first explore the design space of an indoor white space identification system then present WISER's architecture, which consists of real-time sensing module, white space database, and indoor positioning module. They developed Algorithms for Channel Clustering, Location Clustering, Indoor Sensor Placement and Candidate Location Ranking.	Strong channels, easy Location and channel correlation.	They used RF sensors which is more expensive.
5	Professor William Webb	Spectrum sharing: The way to finally realize the M2M vision	IEEE Transaction on Telecommunication, VOL. 23, NO. 7, 2012	Shared access algorithm to the TV band is an unlicensed user which allowed mixing with licensed users as long as they do not cause any interference to users. Weightless is Designing the standard for M2M in white space requires many trade-offs and iterations.	Low cost, Excellent coverage, Ultra low-power operations, Secure and guaranteed message delivery.	M2M traffic is often characterized by very short Messages.
6	Santosh	Broadband	IEEE Globecom	The proposed architecture	They offered a	The performance

	Kawade, Maziar, Nekovee.	Wireless Delivery Using An Inside-Out TV White Space Network Architecture	2011	of the TVWS is based on the use of geolocation technology for location determination combined with database look-up. TVWS spectrum availability data stored in a centrally managed TVWS database. Users with a TVWS modem, or dongle, can connect from outside to community access points via a TVWS channel.	powerful, fast and cost-effective broadband wireless delivery platform.	of TVWS Architecture is limited due to interference and higher attenuation losses.
7	V. Galetic, I. Bojic, M. Kusek, G. Jezic, S. Desic And D. Huljenic	Basic principles of Machine-to-Machine communication and its impact on telecommunications industry and Home Appliances	International Journal of Engineering and Technology, Vol. 3, 2010	They gave a short overview of M2M communication principles and basic architecture. Also present different standardization bodies and their recommendations concerning open issues in the M2M field. Additionally, they gave introduction to Ericsson's 50 Billion Connected Devices strategy for M2M based solutions from various leading telecommunications industry participants such as Ericsson, Nokia, Siemens and Motorola.	They gave brief introduction about M2M communication principles and their architectures.	They produced only theoretical overview of M2M communication.

III. COMMUNICATION MODULE

A universal asynchronous receive/transmit (UART) is an integrated circuit which plays the most important role in serial communication. It handles the conversion between serial and parallel data. Serial communication reduces the distortion of a signal, therefore makes data transfer between two systems separated in great distance possible. It contains a parallel to serial converter for data transmitted from the computer and a serial to parallel converter for data coming in via the serial line [8]. The UART also has a buffer for temporarily storing data from high speed transmissions [10]. In addition to the basic job of converting data from parallel to serial for transmission and from serial to parallel on reception, a UART will usually provide additional circuits for signals that can be used to indicate the state of the transmission media and to regulate the flow of data in the event that the remote device is not prepared to accept more data. UART must have a larger internal buffer to store data coming from the modem until the CPU has time to process it [9].

The UART serial communication module is divided into three sub modules: the baud rate generator, receiver module and transmitter module. Therefore, the implementation of the UART communication module is actually the realization of the three sub modules [11]. The baud rate generator is used to produce a local clock signal which is much higher than the baud rate to control the UART receive and transmit; The UART receiver module is used to receive the serial signals at RXD, and convert them into parallel data; The UART transmit module converts the

bytes into serial bits according to the basic frame format and transmits those bits through TXD [12].

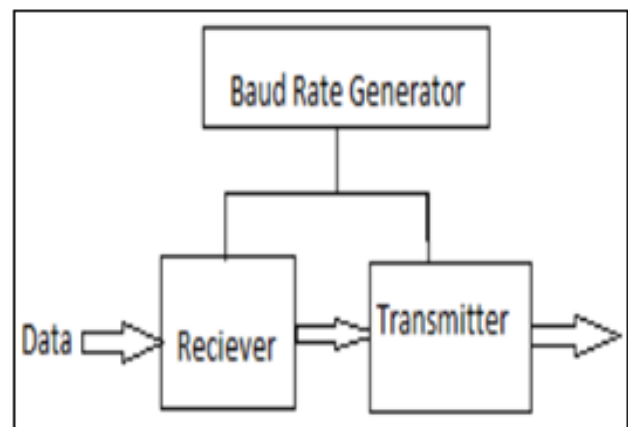

Figure 2: UART Module

A. Baud rate generator

Baud Rate Generator is actually a kind of frequency divider. The baud rate frequency factor can be calculated according to a given system clock frequency and the required baud rate. The calculated baud rate frequency factor is used as the divider factor. Assume that the system clock is 50MHz, baud rate is 9600bps, and then the output clock frequency of baud rate generator should be $1 * 9600\text{Hz}$. Therefore the frequency coefficient (M) i.e. counts value of the baud rate generator is: $M = 50\text{MHz} / 1 * 9600\text{Hz} = 5208$. When the UART receives serial data, it is very critical to determine where to

sample the data information. The ideal time for sampling is at the middle point of each serial data bit.

$$\text{Count} = \frac{\text{System click}}{\text{Baud rate} \times \text{sampling rate}}$$

As system clock frequency can be internally divided by factor two so that the count will be for 9600 is $5208/2=2604$. Similarly we can calculate count for other standard baud rates as follows

TABLE 1- Standard baud rates

S0	S1	Baud Rate(BPS)
0	0	2400
0	1	4800
1	0	19200
1	1	9600(default)

B. Receiver

In UART serial communication, receiver accepts the data serially and sends at the output in parallel manner. Basically receiver has clk_out, reset and RxD input lines where clk_out gives continuous clock to receiver and from RxD line serial data can be given. At the output level received data can be obtained in parallel manner. The UART communication format consists of a start bit followed by 8 data bits and one stop bit indicating the end of the communication. This block monitors the input line for new data which is indicated by the start bit. When the load signal is high it will get the start bit from the transmitter which assures that the original data is now being send by the transmitter. Once the shift signal is becomes high with no load signal, the data coming from the transmitter gets shifted into the intermediate register of the receiver and provides the 8 bit serial data which we have given as an input to the transmitter. Once the entire data has been sent the parity error and the CRC errors has been checked out and are served as the input to the transmitter. If parity error and CRC errors occur or are at logic 1, it means that our transmission is having some errors.

C. Transmitter

The function of transmit module is to convert the sending 8-bit parallel data into serial data, adds start bit at the head of the data as well as stop bits at the end of the data. The function of the transmitter module is to convert the 8 bit serial data into the single bit data. In this module, when our load signal is high the data in stored into the holding register. The data in the holding register is shifted to the intermediate register with the start bit of zero and this intermediate register is of 9 bits. Once the shift signal is high the least significant bit of the intermediate register i.e. the start bit comes at the output of the transmitter and served as the input to the receiver. When the entire data has been sent, the transmitter provides a parity bit which is served as the input to the receiver.

IV. NEED OF STUDY

Now days, there is growing demand for bandwidth of broadband network. Thus reduce the anticipated strain on the network by taking advantage of unutilized spectrum, such as TV white space (TVWS). TV signals rarely occupy the full spectrum allocated to them. Thus many times much more spectrum is unutilized. So there is wastage of communication spectrum.

CONCLUSION

The white space techniques are widely used in communication systems, and for constructing communication module with equal input and output frequency. Various communication design techniques provide that the overall detection characteristic is shared between several simplified sub modules that operate at the lowest possible unused frequency. Hence, by using the white spaces, the total number of coefficients is significantly reduced. Also there are some white space techniques that are providing the excellent frequency response with consuming less power.

ACKNOWLEDGEMENT

We would like to acknowledge the Faculties of Information Technology Department, Tulsiramji Gaikwad-Patil College of Engineering & Technology, Nagpur for their support. I Shruti S. Kshirsagar specially want to thank my guide Professor and A. G. Fulsunge sir for their valuable guidance and constant encouragement towards the work.

REFERENCES

- [1] Jihye Lee and Taehyun Jeon, "FPGA Based Implementation of Gain Control Block for OFDM System", International Journal of Control and Automation Vol.7, No.2 (2014).
- [2] Joseph Camp, "White Space Networking with Wi-Fi like Connectivity", ACM SIGCOMM Computer Communication Volume 43, Number 5, October 2013.
- [3] Matthias John, Max Ammann, "A Compact Shorted Printed Monopole Antenna for TV White Space Trials", European Conference on Antennas and Propagation - EuCAP, Gothenburg, Sweden, 30 September -4 October 2013,08/04/2013.
- [4] Xuhang Ying, Jincheng Zhang, Lichao Yan, "Exploring Indoor White Spaces in Metropolises", International Conference, MobiCom'13, Miami, FL, USA.
- [5] Professor William Webb, "Spectrum sharing: The way to finally realize the M2M vision", IEEE Transaction on Telecommunication, VOL. 23, NO. 7, 2012.
- [6] Santosh Kawade, Maziar Nekovee, "Broadband Wireless Delivery Using Inside-Out TV White Space Network Architecture", IEEE Globecom 2011.
- [7] V. Galetic, I. Bojic, M. Kusek, G. Jezic, S. Desic And D. Huljenic, "Basic principles of Machine-to-Machine communication and its impact on telecommunications industry and Home Appliances", International Journal of Engineering and Technology, Vol. 3, 2010.
- [8] P. D. Sutton, B. Ozgul, K. E. Nolan, and L. E. Doyle, "Bandwidth adaptive waveforms for dynamic spectrum access networks," in *IEEE International Symposium on New Frontiers in Dynamic Spectrum Access Networks (DySPAN)*, Chicago, USA, Oct. 2014.

-
- [9] Federal Communications Commission, “*Mobile Broadband: The Benefits of Additional Spectrum*”, www.fcc.gov, October 2010.
- [10] Peter Flynn, “*White Space – Potentials and Realities*”, Texas Instruments. August 2013.
- [11] Naroa Zurutuza, “*Cognitive Radio and TV White Space Communications*”, Norwegian University of Science and Technology, June 2011.
- [12] BBC R&D, “*White Paper: Isle of Bute TVWS Trial Network Architecture and Interference Studies*”, November 2012.