

RED TACTON

An innovative Human Area Networking technology.

Ajay Rathore, Mukesh Agarwal, Gajendrav Sharma, Monika Sharma

1 B.Tech, Computer Science and Engineering, JECRC, Jaipur, Rajasthan, India, ajrathore09@gmail.com

2 Professor, Computer Science and Engineering, JECRC, Jaipur, Rajasthan, India, mukeshsir@gmail.com

3 Assistant Professor, CSE, JECRC, Jaipur, Rajasthan, India, Sharma.Gajendra5@gmail.com

4 Lecturer, CSE, JECRC, Jaipur, Rajasthan, India, monikanaina.sharma@gmail.com

Abstract

As electronic devices become smaller, lower in power requirements, and less expensive, we have begun to adorn our bodies with personal information and communication appliances. Such devices include cellular phones, personal digital assistants(pdas), pagers and many more. Currently there is no method for these devices to share data. Networking these devices can reduce functional I/O redundancies and allow new conveniences and services.

RedTacton was introduced by Nippon Telegraph and Telephone Corporation(NTT).

RedTacton is a break-through technology that, uses the surface of the human body as a safe, high speed network transmission path. So we, in this paper are explaining the unique new functional features and enormous potential of RedTacton as a Human Area Networking technology.

In this paper I have described features, applications advantages , disadvantages of redtacton.

evels of connectivity: Wide Area Networks(WAN), Local Area Networks(LAN), and Human Area Networks(HAN) for connectivity to personal information, media and communication appliances within the much smaller sphere of ordinary daily activities[6].

-----***-----

1. INTRODUCTION

We are heading toward an electronic future where information will be accessible at our fingertips, whenever and wherever needed. Some of the computing and communication equipment required to provide this intimate and immediate access to information will be incorporated into our attire. Just as a glance at today's wristwatch saves a trip to the nearest clock, a glance at tomorrow's wristwatch will replace finding a terminal to check e-mail.

RedTacton is a new Human Area Networking technology introduced by Nippon telegraph and Telephone Corporation(NTT's) that uses the surface of the human body as a safe, high speed network transmission path[7]. RedTacton is a break-through technology that, for the first time, enables reliable high-speed HAN. In the past, Bluetooth, infrared communications(IrDA), radio frequency ID systems(RFID), and other technologies have been proposed to solve the "last meter" connectivity problem[7]. However, they each have various

fundamental technical limitations that constrain their usage, such as the precipitous fall-off in transmission speed in multi-user environments producing network congestion.

1.1 WHAT IS REDTACTON?

RedTacton was introduced by Nippon Telegraph and Telephone Corporation(NTT) who combined TACTON - "touch-act-on" Meaning "action triggered by touching" and RED - It is an auspicious color according to Japanese culture for warmth and love creating the name RedTacton[1]. It is a technology that, uses the surface of the human body as a safe, high speed network transmission path. The study of Human Area Networking,

- i.) RedTacton uses the minute electric field emitted on the surface of the human body. Technically, it is completely distinct from wireless and infrared.

- ii.) A transmission path is formed at the moment a part of the human body comes in contact with a RedTacton transceiver. Physically separating ends the contact and thus ends communication.
- iii.) Using RedTacton, communication starts when terminals carried by the user or embedded in devices are linked in various combinations according to the user's natural, physical movements.
- iv.) Communication is possible using any body surfaces, such as the hands, fingers, arms, feet, face, legs or torso. Red Tacton works through shoes and clothing as well.

1.2 FEATURES

RedTacton has three main functional features:

- i.) Touch: Touching, gripping, sitting, walking, stepping and other human movements can be the triggers for unlocking or locking, starting or stopping equipment, or obtaining data.
- ii.) Broadband & Interactive: Bandwidth does not deteriorate even with duplex operations and simultaneous access by many users! Duplex, interactive communication is possible at a maximum speed of 10Mbps. Because the transmission path is on the surface of the body, transmission speed does not deteriorate in congested areas where many people are communicating at the same time.
- iii.) Any media: In addition to the human body, various conductors and dielectrics can be used as transmission media. Conductors and dielectrics may also be used in combination[4].

1.3 PREVIOUS WORK ON ELECTRIC FIELD SENSING

The development of the Human Area Network(HAN) grew out of a meeting between Professor Mike Hawley's Personal Information Architecture Group and Professor Neil Gershenfeld's Physics and Media Group, both at the MIT Media Laboratory. Professor Hawley's group needed a means to interconnect body-borne information appliances, and Professor Gershenfeld's group had been applying electric field sensing to position measurement[5].

1.4 RedTacton Transciever

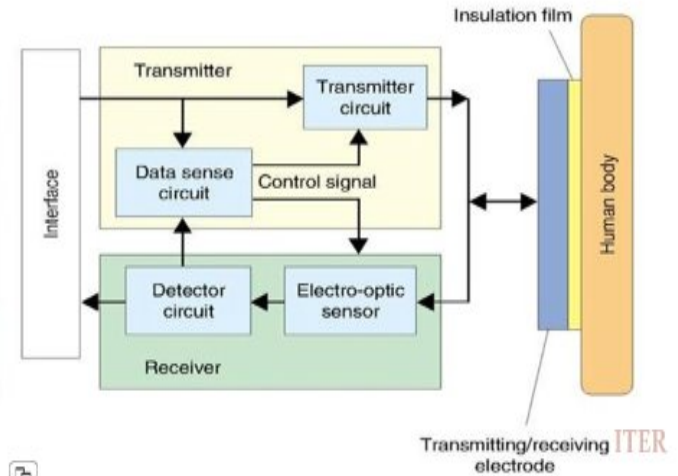

Fig 1. Block diagram of redtacton transceiver[2]

The transmitter consists of a transmitter circuit that induces electric fields toward the body and a data sense circuit, which distinguishes transmitting and receiving modes by detecting both transmission and reception data and outputs control signals corresponding to the two modes to enable two-way communication as shown in fig1.

Implementation of receive-first half-duplex communication scheme that sends only after checking to make sure that there is no data to receive in order to avoid packet collisions. RedTacton takes advantage of the long-overlooked electric field that surrounds the human body.

2. WORKING:

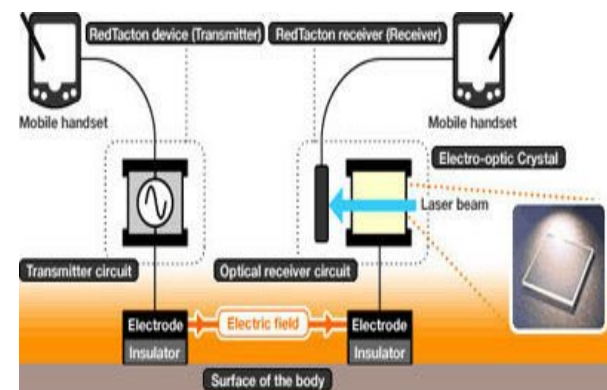

Fig 2. Block diagram of RedTacton working[4]

RedTacton takes a different technical approach. Instead of relying on electromagnetic waves or light waves to carry data, RedTacton uses weak electric fields on the surface of the body as a transmission medium as shown in fig2.

- i.) The RedTacton transmitter induces a weak electric field on the surface of the body.
- ii.) The RedTacton receiver senses changes in the weak electric field on the surface of the body caused by the transmitter.
- iii.) RedTacton relies upon the principle that the optical properties of an electro-optic crystal can vary according to the changes of a weak electric field.
- iv.) RedTacton detects changes in the optical properties of an electro-optic crystal using a laser and converts the result to an electrical signal in a optical receiver circuit.

Multiple transceivers can be used simultaneously. This is because RedTacton uses a proprietary CSMA/CD (Carrier Sense Multiple Access with Collision Detection) protocol that allows multiple access with the same medium from multiple nodes.[4]

2.1 Mechanism of Communication with RedTacton

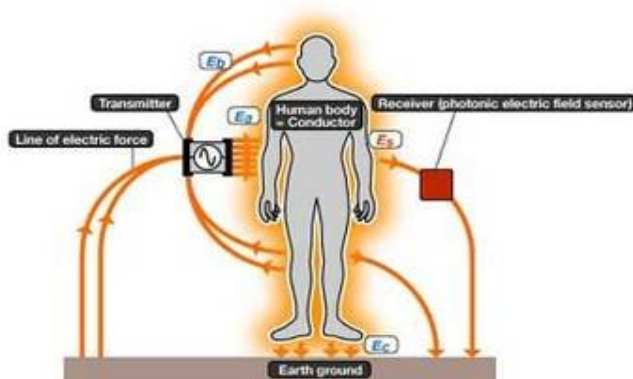

Fig 3. Communication with RedTacton[2]

The naturally occurring electric field induced on the surface of the human body dissipates into the earth as shown in fig3. Therefore, this electric field is exceptionally faint and unstable. The photonic electric field sensor developed by NTT enables weak electric fields to be measured by detecting changes in the optical properties of an electro-optic crystal with a laser beam.

2.2 Human Safety

1. The transmitting and receiving electrodes of the RedTacton transceiver are completely covered with insulating film, so the body of the person acting as the transmission medium is completely insulated. This makes it impossible for current to flow into a person's body from the transceiver.
2. When communication occurs, displacement current is generated by the electrons in the body because the body is subjected to minute electrical fields. However, such displacement currents are very common everyday occurrences to which we are all subjected.
3. RedTacton conforms to the "Radio frequency-exposure Protection standard (RCR STD-38)" issued by the Association of Radio Industries and Businesses (ARIB)[1].

3. APPLICATIONS

RedTacton has wide variety of applications, some of the applications are as follows:

3.1 ONE TO ONE SERVICES

- Enable one-to-one services tailored to the user's situation and tastes.
- Attribute information recorded in the RedTacton device is sent to the touched objects.
- The appropriate service is provided based on the attribute information received by the RedTacton receiver.

1) Elimination of human error:



Fig 4. Elimination of human error.[4]

RedTacton devices embedded medicine bottles transmit information on the medicines attributes. If the user touches the wrong medicine, an alarm will trigger on the terminal he is carrying.

The alarm sounds only if the user actually touches the medicine bottle, reducing false alarms common with passive wireless ID tags, which can trigger simply by proximity. Avoidance of risk at construction sites. (an alarm sounds if special equipment is handled by anyone other than supervisors)

2) Marketing Applications:



Fig 5. Marketing applications[4]

When a consumer stands in front of an advertising panel, advertising and information matching his or her attributes is automatically displayed.

By touching or standing in front of items they are interested in, consumers can get more in-depth information.

Inside a shop, shoppers can view related information on their mobile terminals immediately after touching a product.

3.2 Intuitive Operations

- Natural movements and actions are the trigger (touch).
- RedTacton transceivers embedded in two terminals can communicate not only data but also the control or configuration instructions needed to operate devices (broadband & interactive).

1) Intuitive Operations:



Fig 6. Intuitive operations[4]

Print out where you want just by touching the desired printer with one hand and a PC or digital camera with the other hand to make the link.

Complicated configurations are reduced by downloading device drivers "at first touch".

Transfer songs to portable music players from notebook PCs with just a touch.

2) Instant Private Data Exchange:

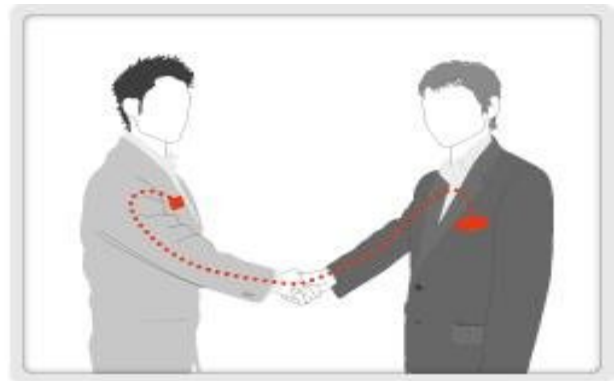

Fig 7. Instant private data exchange[4]

By shaking hands, personal profile data can be exchanged between mobile terminals on the user. (Electronic exchange of business cards)

Communication can be kept private using authentication and encryption technologies.

Group photos taken with digital cameras are instantly transferred to individual's mobile terminal.

Diagrams written on white boards during meetings are transferred to individual's mobile terminals on the spot.

3.3 Personalization

- Digital lifestyle can be instantly personalized with just a touch.
- A pre-recorded configuration script can be embedded in a mobile terminal with built-in Red Tacton transceiver.
- When another device with RedTacton capabilities is touched, personalization data and configuration scripts can be downloaded automatically.

1) Personalisation of Mobile Phones:



Fig 8 .Personalisation of mobile phones[4]

Your own phone number is allocated and billing commences.
Automatic importing of personal address book and call history.
The PC is configured to the user's specifications simply by touching the mouse.

2) Personalisation of Automobiles:



Fig 9 . Personalisation of Automobiles[4]

The seat position and steering wheel height adjust to match the driver just by sitting in the car.

The driver's home is set as the destination in the car navigation system.

3.4 New Behaviour Pattern

- Various conductors and dielectrics can be used as RedTacton communication media and this has the potential to create new behaviour patterns. Walls and partitions can be used as communication media.

1) Conferencing System:



Fig 10 . Conferencing System[4]

An electrically conductive sheet is embedded in the table. A network connection is initiated simply by placing a laptop on the table.

Using different sheet patterns enables segmentation of the table into subnets.

Walls and partitions can be used as communication media, eliminating construction to install electrical wiring.

Ad hoc networking using conductive liquid sprays is possible.

2) Wearable:



Fig 11. Wearable[4]

RedTacton can carry music or video between headsets, mobile devices, mobile phones, etc.

Users can listen to music from a RedTacton player simply by putting on a headset or holding a viewer.

Connecting head mounted displays.

3.5 Security Applications

- Automatic user authentication and log-in with just a touch.
- ID and privileges are recorded in a mobile RedTacton device.
- Corresponding RedTacton receivers are installed at security check points.
- The system can provide authentication and record who touched the device, and when.

1) User Verification Management:



Fig 12. User Verification Management[4]

Carrying a mobile RedTacton-capable device in one's pocket, ID is verified and the door unlocked when the user holds the doorknob normally.

Secure lock administration is possible by combining personal verification tools such as fingerprint ID or other biometric in the mobile terminal.

4 ADVANTAGES

- i.) RedTacton does not require the electrode be in direct contact with the skin.
- ii.) High-speed communication is possible between two arbitrary points on the body.
- iii.) Body-based networking is more secure than broadcast systems, such as Bluetooth which have high range of about 10m.
- iv.) Network congestion due to fall in transmission speed in multiuser environments is avoided.
- v.) Superior than Infrared technology
- vi.) Superior than Wi-Fi.

5 DISADVANTAGES

- i.) It has no compelling applications that aren't already available.
- ii.) Too costly.

6. COMPARISON WITH OTHER NETWORK TECHNOLOGIES

RedTacton surpasses other human area networks in terms of communication performance and user convenience. [3]The comparison between RedTacton and other Human Area Networks are shown in the table:

Evaluation criteria	Wireless				Infrared	Red Tacton
	Wireless LAN	Close-range wireless	Contact less IC cards	Passive wireless ID tag	Standard data communication	
Transfer speed	E	P	P	P	P	E
Communication performance during periods of congestion	P	P	E	E	E	E
Duplex data transfer	E	E	E	P	E	E
Data configuration at initiation of communications	E	E	P	P	E	E
User convenience Tasks required at time of each communication	E	E	P	E	P	E
Synchronization with user behavior	P	P	E	E	P	E

Fig 13. Difference between Redtacton and other technologies

7. FUTURE DEVELOPMENTS

RedTacton has a wide range of unique new functional features and enormous potential as a Human Area Networking technology. NTT is committed to quickly identifying and opening up those application areas with the the most commercial promise for RedTacton, a business development process to be coordinated under NTT's.

8. PROTOTYPES

A. Security Devices (Development Completed)



Fig 14. Portable Card-size transmitter[5]

1) Portable Card-Size Transmitter:

- i.) Transmission rate: 230Kbps
- ii.) Protocol: Proprietary protocol
- iii.) Transmission method: Unidirectional

B. Data Transmission Devices(in Development)

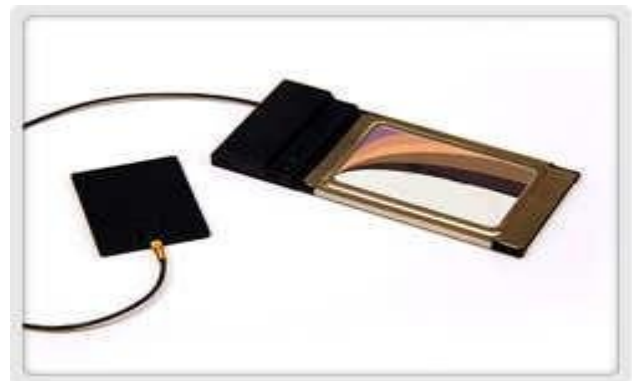

Fig 15. PC card transceiver[5]

2) PC Card Transceiver:

- i.) Transmission rate: 10Mbps
- ii.) Protocol: TCP/IP
- iii.) Transmission method: Half-duplex
- iv.) Terminal interface: PCMCIA

9. CONCLUSION

Nippon Telegraph and Telephone in Tokyo, Japan is pursuing research and development of an innovative Human Area Network technology called RedTacton that safely turns the surface of the human body into a data transmission path at speeds up to 10mbps between any two points on the human body. Using a novel electro-optic sensor a small PCMCIA card sized prototype RedTacton transceiver is already developed[7].

It enables the first practical Human area Networking between body-centered electronic devices and PCs or other network devices embedded in the environment via a new generation of user interface based on totally natural human actions such as touching, holding, sitting, walking or stepping on a particular spot. It can be used for intuitive operations of computer based systems in daily life, temporary one-to-one services, device personalization, security and a host of other applications based on new behavior patterns.[5] NTT is committed to moving RedTacton out of laboratory and into commercial production as quickly as possible by organizing joint field trials.

This technology definitely stands out with perfection, when transfer of data is fast, feasible and more importantly reliable. So, in few years from now everything is going to fall under this super technology. And, finally I conclude,

“FUTURE BELONGS TO RED TACTON”

10. REFERENCES

- [1] <http://www.redtacton.com/en/index.html>
- [2] <http://www.ntt.co.jp/news/news05e/0502/050218.html>
- [3] <http://en.wikipedia.org/wiki/RedTacton>
- [4] http://www.ntt.co.jp/RD/OFIS/active/2005pdf/pdf/h_ct02_e.pdf
- [5] <http://www.taipeitimes.com/News/biz/archives/2005/03/20/2003247076>
- [6] <http://www.physorg.com/news3153.html>
- [7] <http://www.oppapers.com/essays/Redtacton>