

# A Survey on Modeling Line Commutated Converter HVDC Transmission Systems

Vaibhav Varma

MTech Scholar

Department of Electrical Engineering

University Institute of Technology, RGPV, Bhopal

Dr. K T Chaturvedi

Assistant Professor

Department of Electrical Engineering

University Institute of Technology, RGPV, Bhopal

**Abstract**—This paper review about the dynamic phasor model of a line-commutated converter (LCC) high-voltage direct current (HVDC) transmission system. The mathematical definition and properties of dynamic phasors are utilized to model both the dc-side and the ac-side of a LCC-HVDC transmission system as well as 6-pulse Graetz Bridge, which is the building block of such a system. The developed model includes low-frequency dynamics of the systems, i.e., fundamental frequency component (50 Hz) at the ac-side and dc component at the dc-side, and removes high-frequency transients. The developed model, however, is capable of accommodating higher harmonics if necessary. The model is also able to simulate the system during abnormal modes of operations such as unbalanced operation and commutation failure. In order to develop the dynamic phasor model of a line-commutated converter, the concept of switching functions is utilized. The developed model is capable of capturing large-signal transients of the system as well as steady state operating conditions. The model can be used in order to decrease the computational intensity of LCC-HVDC simulations.

**Keywords**- LCC, HVDC, Phasor, Model.

\*\*\*\*\*

## I. INTRODUCTION

The sun High-voltage direct current (HVDC) transmission systems play an integral role in modern electric power networks. HVDC is considered to be a suitable option for such applications like transmission through underground/submarine links, In such cases customary transmission by means of high-voltage air conditioning lines will confront major working difficulties postured by the unnecessary capacitance of the underground submarine links, while the immediate current nature of a HVDC framework won't be affected by the capacitance of the link. connecting air conditioning frameworks with unequal frequencies, In situations where at least two air conditioning electric systems with various frequencies (e.g., 50 Hz and 60 Hz) are to be associated, HVDC transmission frameworks are the main decision to do as such. long-remove transmission - Transmission of electric control over long separations with air conditioning electric systems is constrained by the measure of line reactance. In this manner, keeping in mind the end goal to conquer this issue and to use the full limit of the transmission framework, air conditioning lines must be outfitted with arrangement/shunt compensators to lessen the aggregate reactance. Arrangement remunerated lines may force solidness issues to the system, which require assist examination. Then again, the line reactance isn't of worry in HVDC transmission frameworks as the voltages and streams are dc. In spite of the fact that another type of HVDC frameworks utilizing voltage-source converters (VSC) is likewise created and is the subject of boundless intrigue, the greater part of existing HVDC frameworks depend on traditional line-commutated converters

(LCC). LCC-HVDC plans offer the advantages of a more develop innovation (than the VSC-based frameworks) and are accessible in considerably bigger appraisals than the right now accessible VSC-HVDC frameworks. By and by, VSC-HVDC frameworks exist in control appraisals of up to 1500 MW (per converter), though LCC-HVDC converters of more than twice this rating are regularly accessible Hence, it is foreseen that LCC-HVDC frameworks will keep on playing a noteworthy part later on appropriation of HVDC transmission. The many-sided quality of interconnected power frameworks prohibits a broadened utilization of explanatory strategies for their outline. Constraints of field tests (regarding possibility of investigations and security of the lattice), then again, regularly render them infeasible for down to earth purposes to dissect the conduct of the system. In this manner, PC reproductions for displaying, investigation, plan, and task of energy frameworks have been the act of decision in the course of recent decades since the coming of present day figuring stages. Power framework transient reenactment programs are comprehensively ordered to two sorts:

- Electromagnetic transient (EMT) programs;
- Electromechanical transient projects.

Electromagnetic transient projects are the most precise sort of PC recreation programs for reenacting homeless people in an electric power arrange. EMT test systems are verifiably utilized for the investigation of here and now, quick drifters, which normally incorporate frequencies that surpass the principal; they utilize nitty gritty models and numerically requesting arrangement strategies, which make them

computationally reasonable just for little systems or concentrates with a brief time of premium.

Then again, electromechanical transient projects have been created to consider slower elements, which include motions of machine rotors and commonly incorporate frequencies not as much as the essential. These sorts of projects are additionally called transient dependability programs. The time of enthusiasm for transient steadiness programs is longer than EMT-type contemplates, extending from a couple of moments to a few several minutes. Electromagnetic transient recreation programs, in which high-constancy models of transmission frameworks and power electronic converters are accessible, have been broadly utilized for the investigation and outline of HVDC plans. For example, in [5] the creators examine the displaying and recreation of the primary CIGRE HVDC benchmark framework utilizing two reproduction instruments, to be specific the PSCAD/EMTDC and PSB/SIMULINK, and think about the outcomes. In [6] a method for utilizing advancement empowered electromagnetic transient reenactment for the plan of HVDC framework controls is presented. In this work a succession of reenactment keep running of the system are directed, which are guided by a nonlinear enhancement calculation. In [7] an electromagnetic transient program-based investigation of the CIGRE HVDC benchmark framework working with powerless air conditioning frameworks is completed.

In spite of the exactness of an EMT test system in speaking to quick homeless people inside HVDC frameworks, an EMT test system may undoubtedly be unreasonably nitty gritty for the investigation of extensive, interconnected systems with inserted HVDC, especially when just the low-recurrence elements of the system are of premium. For such cases reproduction of the exchanging homeless people, which are regularly little in greatness, includes superfluous computational many-sided quality and drags out the reenactment time. This issue moves toward becoming exacerbated in current power networks wherein various HVDC converters may meet in close electrical vicinity in plans known as multi-infeed HVDC [8]. Multi-infeed frameworks are known to offer ascent to complex and interfacing homeless people [9], which render displaying with traditional EMT test systems computationally wasteful.

This exploration introduces a computationally ease, normal esteem show for a LCC-HVDC framework utilizing dynamic phasors. Dynamic phasors utilize the semi occasional exchanging nature of a power electronic converter, for which voltages and streams can be spoken to utilizing time-fluctuating Fourier coefficients [4] Dynamic phasor displaying holds the low-recurrence dynamic qualities of a power framework without modeling the high-recurrence homeless people caused by the task of energy electronic switches and converters. Also, a dynamic phasor model can be effectively expanded to represent consonant parts, if so needed.

## II. PREVIOUS WORK

Khaled M. Alawasa , Al-Karak, Jordan ,In the research of Khalid sir the new techniques of Analysis, Demonstrating and Reproduction of Voltage Sourced Converters-Based High Voltage DC Transmission Framework is depicted. Utilizing HVDC rather than High Voltage Elective Current for high power transmission is worthwhile for long power transmissions, mass power conveyance, long submarine power intersection, and low line cost and misfortunes. HVDC converters incorporate Protected Door Bipolar Transistors which are worked with high recurrence Heartbeat Width Adjustment keeping in mind the end goal to gain fast power of both dynamic and receptive power and to make the coveted voltage waveform. There are numerous topologies for voltage source converters accessible for HVDC applications, for example, Two - level and multilevel, fell multilevel converters and secluded multilevel. The focal point of the examination of Khalid is on two levels VSC-HVDC. The task guideline, control procedures of VSC-HVDC is additionally investigated. Recreations for a consecutive VSC-HVDC are directed utilizing PSCAD programming.

S. Singaravelu and S. Seenivasan , Annamalainagar Tamilnadu ,the exploration of Singaravelu portrays a point by point MATLAB recreation model of line commutated converter based Monopolar HVDC framework, encouraging a solid air conditioning system, with a capacitor as a receptive power compensator is presented. He depicted that HVDC require not to work synchronously between two air conditioning frameworks. The inverter is likewise furnished with a present controller to keep up the HVDC framework current steady and a gamma controller for keeping up a consistent eradication edge. In the examination of singaravelu MATLAB reenactment is portrayed effectively for the air conditioner framework too. Wide reproduction work has been finished with the proposed display, to know the cooperation between air conditioning system and HVDC framework. Singaravelu has clearly depicted a very much created, nitty gritty recreation model of Monopolar LCC-HVDC transmission framework with calculation based ideal PI controller for the rectifier and the inverter control.

M. Ramesh and A. Jaya Laxmi Kukatpally, Hyderabad, The research of M. Ramesh depicts Upgrade of energy transmission ability HVDC Framework utilizing actualities controller. He clarify how more prominent execution of energy organize transmission with different line reactance can be achieved. A Adaptable Exchanging Current Transmission Framework is a framework made out of static gear utilized for the air conditioner transmission of electrical vitality. He portrayed to recognize the enhanced Power Transmission Capacity through control plan and far reaching examination for a Bound together Power Stream Controller (UPFC) based on hypothesis, PC reenactment. Advancement in light of these

semiconductor gadgets GTO IGBT first settled high-voltage dc transmission innovation as an other option to long-separate air conditioning transmission. HVDC innovation, gave the premise to the improvement of adaptable air conditioning Transmission framework.

D. Habibinia Y. Najafi Sarem M. Rahim Zadeh ,This exploration portrays Islanding shortcoming of rectifier and inverter substations in HVDC framework both in consecutive and long transmission line frameworks. Islanding shortcoming happens when one of the substation's bolstering air conditioning frameworks has all of a sudden disengaged from Recompense transport bar. In the event that this blame happens at rectifier side of a HVDC framework, it calls rectifier islanding shortcoming generally, the blame happens at inverter side, called as inverter islanding deficiency. To defeat these issues control activities are depicted. Framework's controller consistent activity, beat obstructing of flawed converter and rectifier changing task to reversal mode are three control plans are considered here. Islanding deficiency, contrasting and different issues of HVDC framework (air conditioning shortcircuits, DC line hamper, line break in and converters miss terminating), has low level of event likelihood. Be that as it may, it might be additionally happened and causes uncompensating harms to substations segments, which have high cost. HVDC transmission framework is a standout amongst the most solid methods for exchanging power in this manner, investigation of its qualities and conduct amid numerous possible conditions would be necessary.

### III. DIFFERENT POWER SYSTEM TRANSIENT SIMULATION

#### A. OVERVIEW OF POWER SYSTEM TRANSIENT

Due to the complexity and interconnectivity of large power networks, use of analytical methods for their control, design, operation, and maintenance is extremely challenging if not impossible altogether. Therefore, computer simulation of power systems has been used over the past decades for these purposes.

There are various types of studies that need to be conducted for a power system each involving different components, different portions of the network, and different time-periods of interest. The frequency of interest in power system studies varies from fractions of 1 Hz up to several MHz depending on the types and objectives of studies. Figure 2 illustrates the various types of power system transient studies and their corresponding frequencies of interest [8].

In power system simulations if the frequency range of interest is high, i.e., when a transient phenomenon with rapid variations is to be studied, detailed and accurate models of components and a small simulation time step have to be used in order to properly simulate the network. The models need to contain adequate details to allow representation of the transient phenomenon. If such a study must be done for a large

network, then the simulation becomes slow and computationally expensive, or at times even impossible, to perform. On the other hand, in the studies where the frequency range of interest is low, models with less detail and large simulation time-steps suffice, and simulations for large networks are computationally affordable. Decisions regarding the accuracy of models and solution methods, and the trade-off between accuracy and computational complexity of the resulting simulation need to be made for a study of transients in power systems.

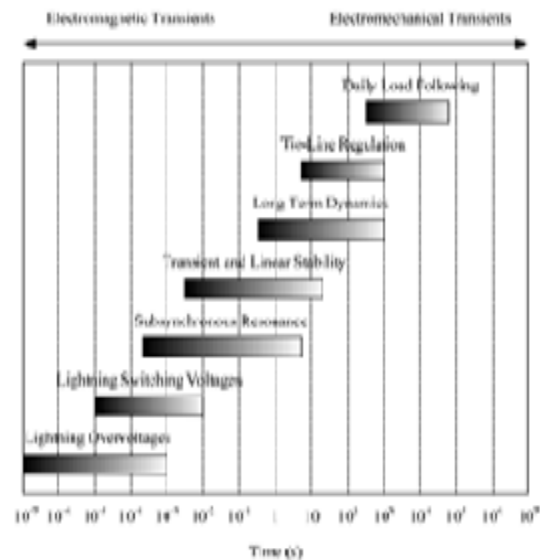

Figure 1: Time scale of power system transients.

#### B. ELECTROMAGNETIC TRANSIENT SIMULATION

Electromagnetic transient (EMT) programs are the most accurate and detailed type of power system transient simulation programs. Component models used in EMT programs contain a large level of details. EMT programs are most suitable for the study of fast transients (usually more than nominal steady state frequency). EMT programs use small time-steps (typically in the order of a few micro-seconds) to properly simulate fast transients. As a rule of thumb, the time step in an EMT program needs to be at least one-tenth to one-fiftieth of the minimum of the smallest time constant and the smallest oscillation period in the system for proper simulation of transient events. Therefore, EMT simulators are suitable choices only for the studies with a small network.

#### C. ELECTROMECHANICAL TRANSIENTS SIMULATION

The period of interest for electromechanical transients is usually between a few seconds to tens of minutes. For this reason, simplified models of power system components are used; otherwise the simulations become too slow and sometimes even impossible to perform. Electromechanical transient programs use a quasi-steady state approach to modeling and simulation, which allows them to use large step

sizes upwards of tens of milli-seconds. In electromechanical transient simulations it is often assumed that the frequency of the electrical network remains constant at the rated, which then allows representation of the ac systems using simplified phasor models. Although this assumption is valid for low-frequency transients, it becomes increasingly inaccurate in the presence of fast-acting and high-frequency system components such as LCC-HVDC. In an LCC-HVDC transmission system if the dc current of the converter is assumed to be purely dc, i.e., comprising only one component with a 0 Hz frequency, the fundamental component of the ac line current will be a sine wave with a fixed amplitude and with a frequency of  $f_s$  (nominal frequency of the electric network, e.g., 50 Hz or 60 Hz). However, during transients the dc current may undergo oscillations and hence will not be constant. If the dc current, during its transient variations, has a low-frequency oscillatory component. As discussed above, both the electromagnetic and the electromechanical transient simulations have their own merits and disadvantages. There is a gap between these two methods of power system simulations, which needs to be filled. A new method of power system simulations is required in such cases where a relatively large electric network needs to be simulated while the dynamics of the ac or dc power system cannot be accurately modeled with the assumption of constant frequency for the (ac) network.

#### D. LCC-HVDC TRANSMISSION SYSTEMS

Figure 2 shows a schematic diagram of a 12-pulse mono-polar line-commutated converter-based high-voltage direct current (LCC-HVDC) transmission system. The system layout shown in this diagram is similar to the first CIGRE HVDC benchmark system [2] which is used as a case study in this research.

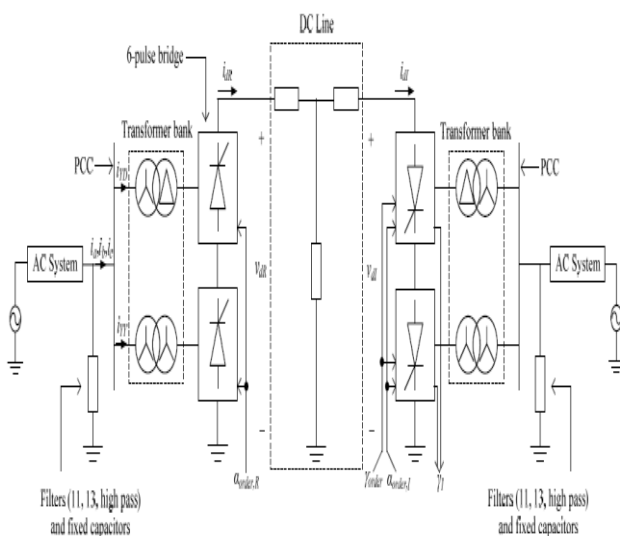

Figure 2: A 12-pulse LCC-HVDC transmission system

#### IV. CONCLUSION

High-voltage direct current power transmission systems are becoming increasingly integrated into modern power networks. The majority of HVDC transmission systems in the world are based upon line-commutated converters. Computer simulations have been a significant part of control, design, and operation of power systems for many years. Different computer simulation programs have been developed for different types of studies in power systems. Among them, electromagnetic transient (EMT) programs are the most accurate one and use the most detailed models of the power system components, which make EMT simulation slow. Therefore, EMT programs are traditionally considered to be suitable only for small networks or studies with the short periods of interest. However, because of the complexity and interconnectivity of the modern power networks, it is necessary to use EMT programs for both larger networks and longer durations of time. Therefore, research needs to be done to develop both new simulation techniques and new models for power system components to accomplish this goal.

#### REFERENCES

- [1] V. D. Habibinia, Y. Najafi Sarem, M. Rahim Zadeh, "Study of inverter, rectifier and islanding fault in hvdc IJTPE March 2012
- [2] Amita, Ramavtar Jaswal " Study of Fundamental Regulators for Control of HVDC Transmission System International Journal of Emerging Research in Management &Technology June 2015
- [3] Dr. S. K. Mahobia , Prof. G. R. Kumrey "study and performance of single-phase rectifiers with various type of parameter" January 2016
- [4] Roberto Rudervall J.P. Charpentier Raghuvveer Sharma High Voltage Direct Current (HVDC) Transmission Systems Presented at Energy Week 2000, Washington, D.C, USA, March 7-8, 2000
- [5] M. Faruque, Y. Zhang, and V. Dinavahi, "Detailed modeling of CIGRE HVDC benchmark system using PSCAD/EMTDC and PSB/SIMULINK," IEEE Trans. on Power Delivery, vol. 21, no. 1, pp. 378-387, January 2006.
- [6] S. Filizadeh, A. M. Gole, D. A. Woodford, and G. D. Irwin, "An optimization-enabled electromagnetic transient simulation-based methodology for HVDC controller design," IEEE Trans. on Power Delivery, vol. 22, no. 4, pp. 2559-2566, Oct 2007.
- [7] M. Faruque, Y. Zhang, and V. Dinavahi, "Detailed modeling of CIGRE HVDC benchmark system using PSCAD/EMTDC and PSB/SIMULINK," IEEE Trans. on Power Delivery, vol. 21, no. 1, pp. 378-387, January 2006
- [8] B. Gemmill and J. Laughran, "HVDC offers the key to untapped hydro," IEEE Power Eng. Rev., vol. 22, no. 5, pp. 8-11, May 2002.
- [9] C. Karawita and U. Annakkage, "Multi-in-feed HVDC interaction studies using small signal stability assessment,"

- 
- IEEE Trans. on Power Delivery, vol. 24, no. 2, pp. 910-918, Apr 2009.
- [10] S. R. Sanders, J. M. Noworolski, X. Z. Liu, and G. C. Verghese, "Generalized averaging method for power conversion circuits," IEEE Trans. on Power Electronics, vol. 6, no. 2, pp. 251-259, April 1991.
- [11] A. Yazdani and R. Iravani, "A generalized state-space averaged model of the three-level NPC converter for systematic dc-voltage-balancer and current-controller design," IEEE Trans. on Power Delivery, vol. 20, pp. 1105-1114, Apr 2005.
- [12] A. Stankovic, B. Lesieutre, and T. Aydin, "Modeling and analysis of single-phase induction machines with dynamic phasors," IEEE Trans. on Power Systems, vol. 14, no. 1, pp. 9-14, Feb 1999.
- [13] A. M. Stankovic, S. R. Sanders, and T. Aydin, "Dynamic phasors in modeling and analysis of unbalanced polyphase AC machines," IEEE Trans. on Energy Conversion, vol. 17, no. 1, pp. 107-113, March 2002.
- [14] A. M. Stankovic, B. Lesieutre, T. Aydin, "Applications of generalized averaging to synchronous and induction machines," in in Proc. North American Power Symposium, B. Lesieutre, 1996.
- [15] A. M. Stankovic and T. Aydin, "Analysis of asymmetrical faults in power systems using dynamic phasors," IEEE Trans. on Power Systems, vol. 15, no. 3, pp. 1062-1068, Aug 2000.