

# CAN Based Hotel Management System

<sup>1</sup>. Avdhut Pawar, <sup>2</sup>. Liladhar Patil, <sup>3</sup>. Priyanka More, <sup>4</sup>. Santosh Ghodke  
Students, Department of EXTC,  
Shivajirao S.Jondhale College of Engineering, Mumbai.

**Abstract**—Everyday life is getting easier with technology and automation. This paper aims at providing automation in restaurants in order to serve foods direct to customer table automatically without waiter. The customer sitting at a restaurant table can order the food using automated LCD display, making it easy for ordering food for both the customer and the hotel management. This paper illustrates a system which helps the customers place their orders directly to the hotel kitchen, with the help of CAN (CONTROL AREA NETWORK) protocol. The paper gives information about using a Microcontroller CAN base protocol device which uses LCD display 16x2 as an output indication and keyboard interface for customer input details. Hence it is not speaker dependent.

Project comprises of three major sections Kitchen, Customer table, and Bill Desk. This 3 sections will be connected using CAN bus on network design by 3 microcontroller. The microcontroller will be used in a project is 8051 microcontroller family IC (89S51).

Using this project customer is enable to order his food from sitting table without any direct contact with food serving waiter, customers order will be directly displayed to the kitchen section and the total amount of bill is calculated and automatically send it to the bill desk. This will help to reduce the manpower required to service the customers and at the same time can handle as many table requirements.

The paper aims at bringing automation in hoteling industry which will change the traditional food ordering and serving method in restaurants. This change will bring more transparency and easiness in food ordering system at restaurants.

**Keywords**—CAN Protocol; CAN Bus; Microcontroller 8051.

\*\*\*\*\*

## I. INTRODUCTION

**Control Area Network** is a vehicle bus standard designed for Microcontroller and devices communicate with each other without host computer. This bus originally developed by Bosch group in 1983, protocol standardized by SAE and controller chip designed by Intel in 1987.

It is two wire differential half duplex, high speed network system, specifically designed for automotive application car window, door and airbags.

CAN is message based protocol for high speed application using short message. The message consists of identifiers which represent the priority up to 8 data bytes.

The BUS offers data transfer rate of 1M bits/sec up to 40 feet. Protocol can link up to 2032 devices on a single network (practically 110 node). It has ability to self-diagnose and repair errors and operates in harsh environment. Faulty nodes are automatically dropped from the bus. This helps to prevent any single node from bringing the entire network down.

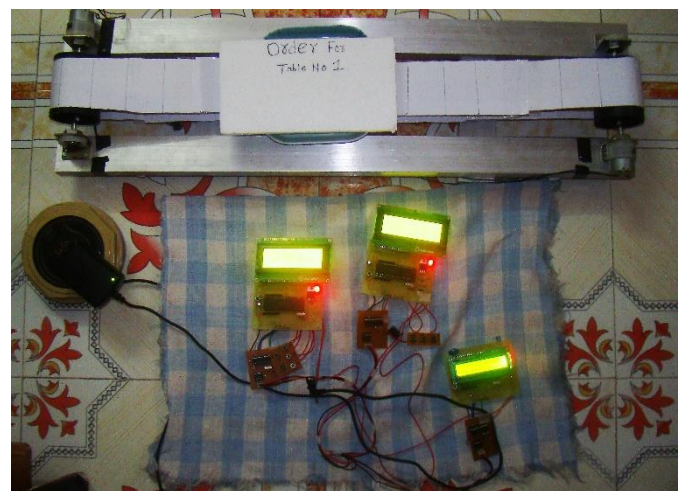

Figure 1: CAN BASED HOTEL DEMONSTRATION

The CAN bus protocol is defined by the ISO 11898-1 standard and can be summarized like this: The physical layer uses differential transmission on a twisted pair wire. A non-destructive bit-wise arbitration is used to control access to the bus. A Controller Area Network (CAN bus) is a robust vehicle bus standard.

Each system connected to the CAN bus is referred as a Node. Each node consists of following components,

### Host Processor, CAN controller, CAN transceiver

**Host Processor** decides which message it want to transmit and what received messages. Sensors, controllers and actuators are connected to host processor.

**CAN controller** stores received bit serially from the bus until an entire message is available, which can then fetched by host processor (trigger an INT) and also stores transmits messages.

**CAN transceiver** adapts the signal level from the bus to the level that CAN controller accepts and vice versa.

## II. Main system

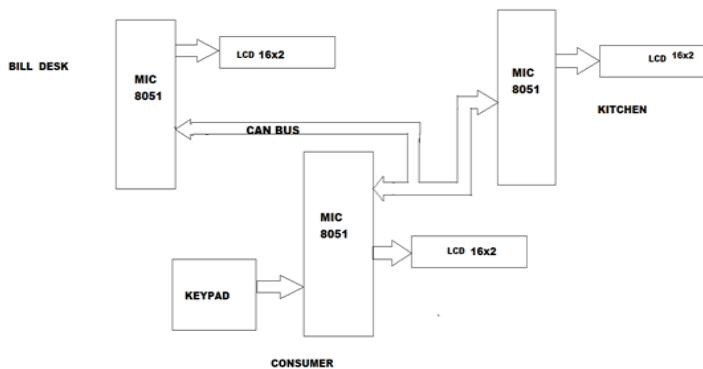

Figure2: CAN BUS SYSTEM.

In these Project CAN bus is used as a communication BUS between all 3 microcontroller circuitry i.e. all controllers communicate with each other via common communication link.

There are three sections (Nodes) in system

- (1)Kitchen Section.
- (2)Service Table.
- (3)Bill Desk.

These sections are controlled by their respective microcontroller as we know there are 4 and connected to LCD 16x2 in every section. This LCD will display concern indication and provide user interface which are operated via keypad attached at one of microcontroller. This keypad is accessible by user to be placed an order (input). As per selection of food menu input this will be written price tag of concern food item which will be displayed at user output LCD as well calculated bill will be displayed on bill desk to generate bill. Selected food items will be shown to LCD present at kitchen section. All communication is traced via microcontroller and data is transferred via CAN bus communication link.

Each node consists of Microcontroller IC 89S51 as a host processor, CAN controller IC MCP2515 and CAN transceiver IC SN65HVD233-HT 3.3-V.

Project is implemented with CAN 2.0A, as device uses 11bit identifiers, so that system is capable of serving total 2048 number of nodes.

Conveyer belt is designed to carry food orders from kitchen to the customer table with order number plate.

If ordered food is unavailable at the moment kitchen node can communicate with table and re modify the order, accordingly total bill amount will be modified at the bill counter.

## III. VIRTUAL HOTEL SYSTEM VIEW.



Figure3: Customer Section

The CAN communication protocol is CSMA/CD (carrier sense multiple access). In this protocol, every node on the network must monitor the bus for period of time. In this period of no activity occurs, every node on the bus has an equal oppotunity to transmit a messge (Multiple Access).

The CD stands for Collision Detection. If two nodes on the network start transmitting at the same time, the nodes will detect the 'collision' and take the appropriate action.

In CAN protocol, a non-destructive bitwise arbitration method is utilized. This means that message remain intact after arbitration is completed even if collisions are detected. All of this arbitration takes place without corruption or delay of the higer priority message.

## IV. CONCLUSION

Project supports minimal human efforts and provides optimum service in ordering food without any human interaction. This will reduce the required man power in hoteling industries and investment in production and maintenance. Also project introduces an embedded system with a combination of CAN bus systems.

General aim of this project is to implement CAN protocol in a Commercial Application like hotel management systems.

Our aim is to use this technology on a small scale commercial hotel industries. These project is an example of adapting new automation technique in cost effective manner. So these technology is suitable for the small scale businessmen who wants upgrade their service quality in business without investing higher amount of money.

#### V. Acknowledgment

We have a great pleasure for representing this project report entitled “**CAN BASED HOTEL MANAGEMENT SYSTEM**” and we would love to take this opportunity to convey our immense regards towards all the distinguished people who have their valuable contribution in the hour of need. We take this opportunity to thank Prof. S.A. LONKAR, Head of the Department, Electronics and Telecommunication, for giving us an opportunity and the most needed guidance throughout the duration of the course and also Prof. S. K. Srivastava for the guidance and necessary support during each phase of the project. We also owe to our fellow colleagues who have been a constant source of help to solve the problems that cropped up during the project development process.

#### REFERENCES

- [1]. B.Gmbh, “CAN specification” vol 1 Version 2.0, 1991, 17(8).
- [2]. Kumar, M. A. Verma, and A. Srividya, Response-Time “Modeling of Controller Area Network (CAN). Distributed Computing and Networking, (25-64).
- [3]. Pazul, “Controller Area Network (CAN) Basics”, Microchip technology Inc., AN713, May 1999, 28(12).
- [4]. Prodanov, W., M. Valle, and R. Buzas, A controller area network bus transceiver behavioral model for network design and simulation. IEEE Transactions on Industrial Electronics, 2009, 56(9): p. 3762-377.
- [5]. Tindell, K., A. Burns, and A.J. Wellings, Calculating controller area network (CAN) message response times. Control Engineering Practice, 3(8).
- [6]. Wilfried Voss, A comprehensive guide to controller area network, Copperhill Media Corporation, 2005.