

Arduino Based Sensor for Fuel Tank Monitor

Dr. J P Patra
Professor, Dept. of CSE
SSIPMT, CSVTU, C.G, INDIA
Patra.jyotiprakash@gmail.com

Rishabh Namdeo
B.E 8th Sem, Department of Information Technology
SSIPMT, CSVTU
Raipur, India
Rishabh.namdew@ssipmt.com

Ankit Jain
B.E 8th Sem, Department of Information Technology
SSIPMT, CSVTU
Raipur, India
Ankit.jain@ssipmt.com

Abstract: A fuel level sensor for the purpose of sensing and monitoring the level of remaining fluid in a container depicting a fuel tank for vehicles is to be discussed. The system will basically be a prototype because of the risks associated with the usage of fuel for all practical purposes. The design would be fairly simple for the prototype but the complexity will keep on increasing as we move towards its physical implementation. The device thus discussed, hopes to find its major application in the automobile industry. But since it is capable of determining the level of remaining ‘fluid’ and not just ‘fuel’, this application of this device may be incorporated in others fields as well. Though, it is inevitably true that even on an expanded range of application, the two most common fluids associated with this device would be either different types of domestic or industrial fuels, or water for the rest of the applications. Here, we will be incorporating LEDs for the role of indicating the level of fluid. The accuracy of the output here can be improved by increasing the number of levels and thus increasing the number of indicating components in this device. But, since we are using discrete components for both sensing and indication, there will exist a certain limitation to which the accuracy of this device can be improved. [1]

1. INTRODUCTION

This project titled ‘Fuel Gauge’ is based on the technology of embedded system. An overview of this project has been provided in the abstract already. Here, in the introduction, we will brief some more technical specifications of this device. The controlling component

of this device is an Arduino board, which is an open source multifunctional electronic board. It contains an ATMEL 328 as its controlling IC. Is able of processing both analog and digital inputs through the provided GP I/O pins. The pins suitable for analog I/O are structurally separate from those used for digital I/O. This provides both flexibility and ease of use. The device, apart from indicating the level of remaining fluid, is also capable of calculating the cost of the fluid based on the quantity remaining and the price been defined already. This information is provided to the user with the help of an LCD display. This LCD display is interfaced to the Arduino board and is capable of reading data from the board and display the calculated parameters accordingly. There is also a provision for altering the price set per unit volume for the fluid to be examined. What this device is

not capable of doing is to detect the fluid sample, and set the price for the thus detected sample automatically. For this feature to add, we may either need to pre-feed some calibrated data into the controlling IC in which case, the variety of samples which can be examined will become small in numbers or if we wish to increase the number of recognizable samples, we may have to use some external memory to serve as a database for the controlling element for matching the obtained output with the previously fed data and produce the output accordingly.[3]

2. PREVIOUS WORK

These are some of the Machine Learning projects which have been developed earlier:

- a. Inventor : Lawrence Kjerulff
Original Assignee: Lawrence Kjerulff
Priority date: 1905-07-06
Water level Indicator (US829161A US Grant)[4]
- b. Author : Poynting J
Publication year: 1885
Publication venue: Philosophical Transactions of the Royal Society of London

On the connexion between electric current and the electric and magnetic inductions in the surrounding field.[4]

- c. Inventor : Charles May
Original Assignee: Charles May
Priority date: 1901-12-21
Means for ascertaining the level of liquids. (US712699A US Grant)[4]
- d. Inventor : John Thomas Dawes
Original Assignee: John Thomas Dawes
Priority date: 1905-06-23
Water level Indicator (US824098A US Grant)[4]
- e. Inventor : G Werner
Original Assignee: G Werner
Priority date 1971-03-01
Liquid level Indicator (US3709038A US Grant)[4]

3. METHODOLOGY

To understand properly about the functionality of this device, we must first start at the component level. In this journal, to achieve conciseness, only the necessary specifications will be listed and for any further information, links to resources containing the original data sheets as provided by the manufacturer will be listed in the ‘reference’ section.[3]

It is to be noted that we won’t be discussing ‘connecting wires’ as a component here. Still, it is not possible to completely overlook its contribution and hence its scope will be limited to the listing alone.

The main components used in this project are:

- a. Arduino board
 - b. LCD display
 - c. LED lights
 - d. Connecting wires
 - e. Container(as a depiction of a fluid storage)
- a. Arduino board

The Arduino board which we have used in this project, is an open source multifunctional electronic board. It is equipped with dual power supply (USB and external), and is capable of being operated in the range of 7-12V as an input. It has been provided with 6 analog I/O pins which also serve as a built in ADC. It has 13 General I/O pins and some other port pins. 6 of the available General I/O pins are capable of supporting PWM (Pulse Width Modulation) as well. Other than that, it has two port pins dedicated to serial transmission and reception. All of the further details regarding Arduino Uno can be

obtained from the resources in the ‘reference’ section.[2]

- b. LCD Display
An LCD presents information on a small display panel or screen by using one or more segments that change their appearance in response to an AC voltage. Here, we have used a basic monochrome LCD because of its low power consumption. In an LCD, incoherent light emerges from the backlight panel and then enters a vertical polarising filter that limits the electric field vector. The polarised light then enters a liquid crystal which is a liquid composed of molecules organised in a regular helical structure that rotates the polarity by 90 degrees when no voltage is applied to it. The light then passes through a horizontal polarising filter and is visible to the user.[2]
- c. LED

An LED (Light Emitting Diode) is a device that emits light in response to a small current, at a voltage lower than 5V DC. It is usually moulded from epoxy or silicone that may be colourless but translucent or tinted. The colour of the light is initially determined by the chemical compounds used internally, and by their dopants. Thus a water-clear LED may emit coloured light. LEDs are most commonly used as miniature incandescent bulbs or for showing the status of a device. Here, the LED is being used as an indicator.[2]

- d. Container
This component has the sole purpose of acting as a depiction of a fuel tank or a fluid storing body and is clearly not bounded by any technical specifications.[2]

Working

- a. First the Arduino board was connected and the software were updated
- b. Then the Arduino board and the bread board were connected using the GPIO extension board.
- c. All the connections were made according to the schematic diagram thus shown.
- d. Two ground cable were connected from the GPIO pins. And one ground cable is connected to the bread board. This cable will go in the base of the container so that when the other cable is in the water the circuit is completed.
- e. After the circuit gets completed, the level of the fluid will be shown in the LCD display.

- f. Apart from the level of the fluid, the cost of the fluid remaining in the container will also be shown as the program for calculating the cost has been fed already.
- g. Details regarding both the quantity and the cost of the remaining fluid to be examined can be observed in the LCD display.

Diagram

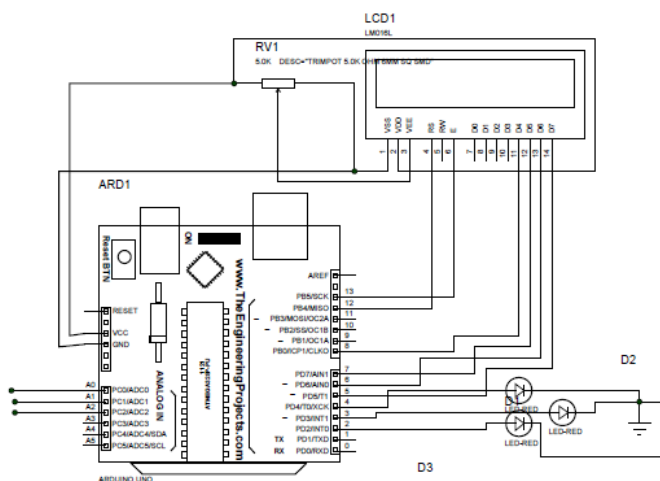

Fig1 . Circuit Diagram

Description of the diagram

The above figure consists of arduino board in which a 16*2 LCD display and three LED's are connected. The pins of LCD are connected to arduino's data pin which provide output. The LED one terminal is connected to +5V (VCC) supply of arduino board and other end is connected to GND. The end in which GND is connected is dipped into the container. The GND of arduino is also dipped inside the container at different levels so that when they get connected the LED glows and display the result.[5]

4. RESULT

The cord is dipped inside the container as the fuel is filled in the container the cord senses some moisture through moisture sensor indicator and gives the signal high to the board which results to glowing of LED connected to it and that calculates and display the resulting amount of fuel in the LCD display.

5. DISCUSSION & CONCLUSION

The Fuel Gauge successfully provides the output i.e. amount of fuel inside the container.

The main function of Fuel Gauge is that whenever the fuel is inserted inside the container the cord is dipped in it through which it gives the (GND) i.e. low on the LED and on other side the (VCC) +5v supply is connected and thus LED glows and it defines the level and calculates the amount of fuel in that particular level.

The objective of the project was to recognize an input image for its further processing according to the situation which is successfully achieved.

6. FUTURE SCOPE

At present the application only calculates the amount of fuel in a particular level which is distinguish accordingly inside the container which only gives the level and calculates amount of fuel not its quantity, But in future, we will enhance to show the quantity of fuel also present inside the container.

7. REFERENCES

- [1] <https://makezine.com/>
- [2] <https://archive.org/details/EncyclopediaOfElectronicComponents.Volume2CharlesPlatt>
- [3] Articles from Google Scholar
- [4] US patents(Patent no. mentioned in respective places)
- [5] <https://easyeda.com/editor>.