

Tools and Techniques used in Optimization of Machining Parameters in CNC Lathe Turning of Aluminium 7075 Alloy

¹Navneet Saini

²Dr. Sunil Dhingra

¹M Tech student, MIET, Kurukshetra university, Ambala

²Assistant Professor, UIET, Kurukshetra university, Kurukshetra

Abstract: This paper presents complete process of turning operation by using CNC machine tool and the input parameters associated with the process that can be controlled to enhance the output quality parameters like material removal rate and average surface roughness as per the desired requirement. Every detail of turning operation and associated parameters is explained. The optimization techniques like Taguchi, Anova, S/N ratio, grey relational analysis is also described and their importance is also discussed in detail. The study explains step by step procedure involved in optimization of turning process in detail.

Keywords: CNC, Taguchi, S/N ratio, GRG, MRR

1.Introduction

In metal based manufacturing industry CNC turning operation plays an important role. The present scenario demands for better quality in terms of surface finish and high productivity with precise tolerance which leads the metal cutting industry to improve the quality control of the machining process [1]. Surface roughness and material removal rate are the two important parameters which decide the productivity of the machining process. Efficiently turned products are superior in many ways like excellent tolerance, less tool wear, good surface finish, high corrosion strength and contact friction etc. to achieve these properties CNC machine tool is the best choice as it controls the output efficiently by increasing the the productivity and profit [2]. The parts for automotive, aerospace, die and mould manufacturing industry use CNC turning operation for the machining purpose. In such large industries both surface finish and MRR are of great importance. Both these output parameters can be achieved by optimizing the process parameters like speed, feed, depth of cut etc. however very high cutting speed is not always favourable for the machining process as it can cause vibrations and excess power consumption [3]. Also it is not good for tool as tool life decreases at high speeds and for the product also as dimensional inaccuracies are high at such cutting speeds. Selection of tool apart from proper input parameters is another aspect for turning process as proper tool material has to be selected according to the work piece material [4]. Coated cemented carbide tool is good for the machining of aluminium alloys. Cemented carbide tools maintain their hardness over a wide range of temperature. In recent years,

thin film hard coating on carbide tools has improved the property of wear resistance and built up edge formation which was present in lubricious uncoated carbide [5]. To minimize the surface roughness it is essential to optimize some of the cutting parameters. Optimization is process of getting the best result subjected to several constraints. In modern manufacturing industry optimization is of great importance to meet the expected demand for product quality and high production rate. Surface roughness is one of the important quality parameter that decides the efficiency of the turning process. At the same time higher material removal rate is also important to save the production time. Both these output parameters are optimized using taguchi method which helps to find the optimum set of turning process parameters [6, 7]. The present study uses speed, feed, depth of cut and nose radius as the input parameters and objective is to find the set of input parameters where we get the best set of surface roughness and material removal rate.

1.1 The Turning operation

Turning operation can be defined as the process of removing metal from the outer surface of a cylindrical work piece which is rotating at a constant speed held tightly between chucks. Turning process is used to reduce the work piece diameter to achieve desired dimensions and smooth surface finish. It is a very precise machining operation that produces smooth cylindrical surfaces by removing excess material with the help of a cutting tool [6]. In turning operation a single point cutting tool is held tightly in a tool holder which is fixed at a tool post. Now this single point cutting tool is fed past against a rotating work piece in a direction parallel

to the axis of the rotating work piece [7, 8]. The material is removed in the form of chips and a cylindrical or more complex profile is achieved. This operation is carried out in a conventional lathe machine manually by a skilled operator. Now, a day CNC machines are used which are highly automated and controlled by program for turning, drilling purpose etc. the mechanical parts are designed with the help of CAD software and proper dimensions re entered here which on later stage can be converted in to a manufacturing program using CAM software. The resulting program is a set of instructions and commands which is loaded in to the CNC machine via post processor software to produce the product of desired dimension.

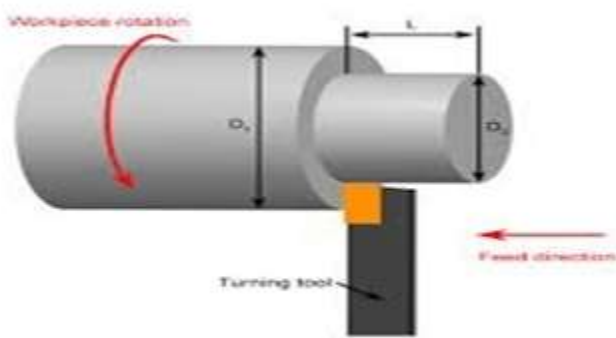

Figure 1.1 Showing Turning operation

1.2. Turning operation adjustable parameters

The basic input parameters in turning operation are spindle speed, feed rate and depth of cut. Other factors like material composition and type of tool used also influences the turning operation but speed, feed rate and depth of cut can be altered by giving instructions to the machine during the operation [10].

1.2.1. Spindle speed

Spindle speed is the rotating speed of the spindle and the work piece. It is expressed in revolutions per minute (rpm) it tells their rotating speed. In the present study input parameter is taken as spindle speed for optimization purpose

1.2.2. Feed

Feed rate or simply feed can be defined as the rate at which the tool travels along its cutting path. In CNC lathe machine the feed rate is expressed in either mm/rev or mm/min. In the present work it is expressed in mm/min.

$$F_m = f \times N \quad \text{mm/min.}$$

Here F_m is the feed in mm/minute, f is the feed in mm/rev and N is the spindle speed in RPM. [10]

1.2.3. Depth of cut

Depth of cut can be defined as the thickness of material removed in a single pass during the turning operation. It is the thickness between the uncut surface and cut surface which is expressed in mm. an important thing to notice is that the work piece diameter reduces by two times the depth of cut as the layer is removed from both sides of the work piece.

$$D - d = 2 \times \text{DOC} \quad \text{in mm} \quad 1.2$$

Here D and d represent initial and final diameter (in mm) of the job respectively [10]

1.2.4. Machining time

This depends on the feed, speed and length of the work piece. Machining time express in minutes in the present work.

$$T = \frac{L}{F_m} \quad 1.3$$

Where T = machining time in min., L = length of work piece in mm, F_m = feed in mm/min

1.2.5. Material removal rate

The material removal rate is the volume of the ring shaped layer of the material that is removed during the turning operation. It is expressed in mm^3/min [12].

$$\text{MRR} = \frac{\text{Initial weight} - \text{Final weight}}{\text{Density} \times \text{time}} \quad 1.4$$

Where initial and final weight (in grams) of specimen was measured using digital weight measuring machine and Density (ρ) of AL 7075 T6 is 2.81 gm/cm^3 which is first converted in to gm/mm^3 and then used in the equation and time taken to complete the turning is taken in minutes.

1.3. Tool Geometry

The property of the tool and work piece material decides the tool geometry. There is a standard terminology for a single point cutting tool which is shown in the following figure. For single point tools, the rake angle and the end relief angle and side relief angle are the most important.

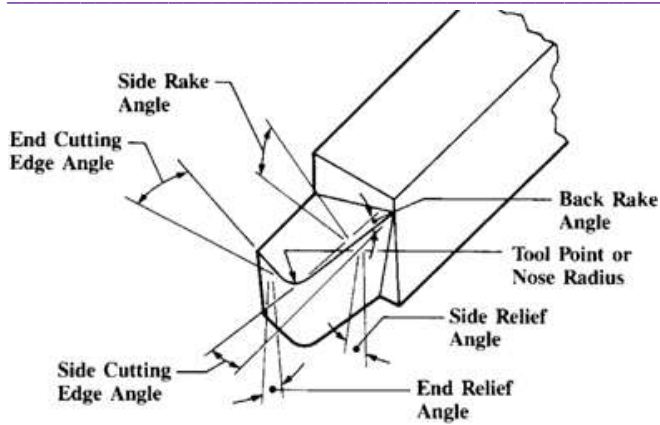

Figure 1.2 shows single point cutting tool [64]

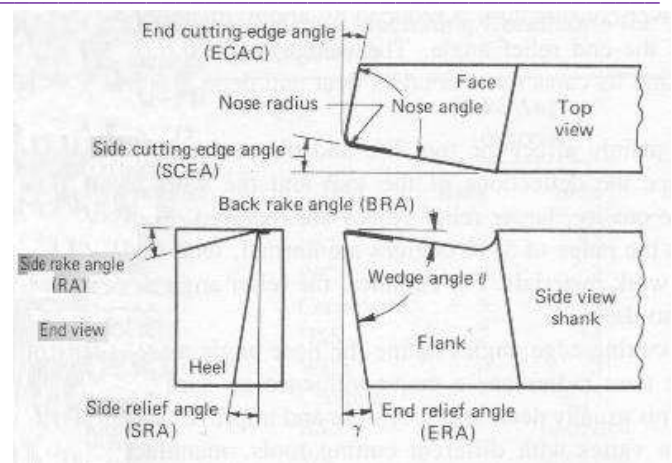

Figure 1.3: Angles of single point cutting tool [65]

1.3.1. Face

The upward flat surface of the single point cutting tool is known as face. The work piece rotates through that flat surface during turning operation.

1.3.2. Flank

A flat surface adjacent to the face of the single point cutting tool is known as flank. When tool is fed in to the work piece the side flank face the direction of feed and the end flank face the machined surface.

1.3.3. Back rake angle

Back rake angle can be defined as the angle between the face and the line parallel with base of the single point cutting tool in a plane perpendicular to the side cutting edge. Back rake angle is positive if the slope of the face is upward with respect to nose, it is negative if the slope of face is downward with respect to nose. Back rake angle is helpful in removing the chips away from the work piece.

1.3.4. Side rake angle

Side rake angle tells about the thickness of the tool behind the cutting edge. It is the angle between the surface of the flank and the perpendicular line to the base. It provides clearance between tool and work piece to prevent rubbing of work piece to prevent rubbing of work piece face of the tool.

1.3.5. End relief angle

End relief angle is the angle between the end flank which is just below the cutting edge and a line perpendicular to the tool base. It helps the tool to cut the work piece without rubbing.

1.3.6. Side relief angle

Side relief angle is formed by the tool side flank and the vertical line measured at right angles to the side. It helps the cutting tool to enter the material without any interference.

1.3.7. End cutting edge angle

The angle between the cutting edge and line which is perpendicular to the shank. It provides clearance between the cutting edge of the tool and the work piece.

1.3.8. Side cutting edge angle

The angle between the straight cutting edge and the line perpendicular to the shank. It keeps the chip away from the machined surface.

1.3.9. Nose radius

The rounded tip that makes a contact with the work piece during cutting operation is the nose radius. It is located on the cutting edge of a single point cutting tool. Nose radius value varies from 0.2mm to 1.2 mm which depends on several factors like feed rate, depth of cut, type of cutting operation, type of tool etc [10].

1.4. CNC (computer numerical control)

The CNC system has a computer in it, which controls the functions. In the conventional system the control is hard wired and therefore any modification or addition in facility call for many changes in the controller which may or may

not possible due to limitations of basic configurations. As compared to this in a CNC system a bare minimum of electronic hardware is used while software is used for the basic function. That is why it is sometimes termed as software control. This assists in adding extra facilities conveniently without much problem and cost. Since these computers are dedicated type, they need comparatively much less storage and with the present cost and high reliability [15]

A typical CNC system consists of the following six elements.

1. Part Program.
2. Program input device.
3. Machine control unit.
4. Drive system.
5. Machine tool.
6. Feedback system.

1.4.1. Working principle of CNC machine

In CNC machine a computer dedicated for the sole purpose perform all the function of the CNC machine as per the instructions of the program stored in the memory of the computer. The system directs the instructions to servo drives so that servo motor can perform its function and other devices like relays, solenoids etc. can start the basic operations like start and stop the motor, coolant on and off, changing the tool, changing of pallet etc. and other miscellaneous functions. Once the command is given by the system it becomes necessary that the function is completed. To ensure that a feedback device provides the feedback continuously Continuous feedback device are used as a position feedback of motor like linear scale, resolver, encoder etc. miscellaneous operations are also maintained y some sensors like proximity switch, pressure switch, limit switch, float switch and flow switch etc. it can be observed that all the operation are continuously monitored by the help of feedback devices in a CNC machine. That is why CNC system is also known as closed loop system as in case of any incomplete task system shows a “fault message” [16].

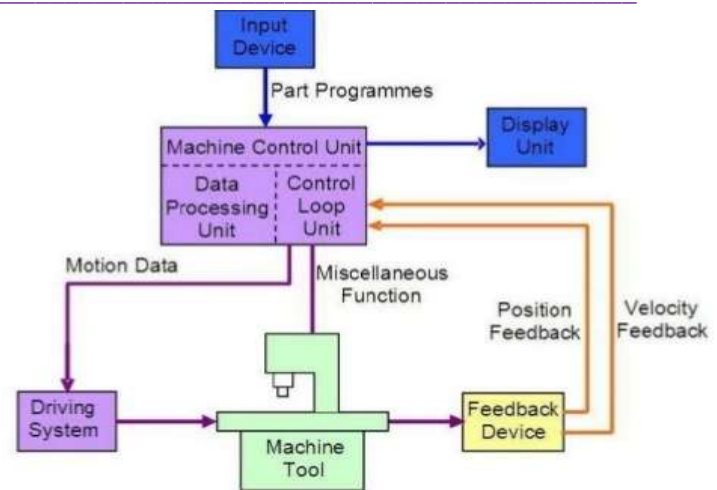

Fig 1.4: Working Principle of CNC machine [66]

1.5. Cutting Tool: a cutting tool can be defined as a sharp edge tool used to remove excess material from the work piece by direct contact with the work piece by the action of shear deformation, which results the removal of material from the work piece in the form of ring shaped layer [8, 17]. The characteristics of an efficient cutting tool are

- (a) **Hardness:** Hardness is the property of the material with which it can cut the other material so tool material should be harder than the material of work piece.
- (b) **Hot hardness:** It is important to maintain the hardness of a cutting tool at high temperatures during the machining operation. An efficient tool is able to maintain its hot hardness at elevated tempratures.
- (c) **Wear resistance:** Tool life is described by the help of this property, it is an important property that tells us about the productivity of the tool and economics of the machining process.
- (d) **Toughness:** The ability of a material to withstand shocks and vibrations is known as toughness. During the machining operation tool has to withstand various shocks and impacts with out breaking.

1.5.1. Cutting Tool Insert

Inserts are cutting tool available in various shapes that can be screwed or clamped in a tool holder available in various sizes according to the tool post where this tool holder is to be fixed. Inserts are fitted in a tool holder through a locking mechanism. When one edge of an insert wears out it can be replaced by another edge of the same insert by rotating it and fixed in a tool holder with the help of locking and unlocking mechanism. It an advantage of using insert that makes the machining process economical which makes use

of all the edges of the insert. Inserts are available in various shapes and sizes which are shown below



Figure 1.5: Inserts of various shapes [67]



Figure 1.6: Insert tool holder [68]

1.6. Surface Roughness

Roughness can be defined as the index of surface texture. Roughness can be understood as the deviation of the real surface with respect to its ideal form in the direction of the normal vector. The surface is said to be rough if these deviations are large, the surface is smooth if these deviations are small. Roughness is an important quality parameter as it tells us that how an object will interact with its environment. Surface which is rough wear more quickly than the surface which is smooth and also rough surface have higher coefficients of friction.

There are various type of irregularities associated with roughness, if distance between peaks and valleys on a surface is small, the wavelength is also small and the appearance of the surface is rough. This type of irregularity is due to the cutting tool action and is categorized as primary texture. If the distance between the peaks and valleys on a surface are large than such irregularity is known as waviness and categorized as secondary texture. This is due to the imperfection in the machine tool [20].

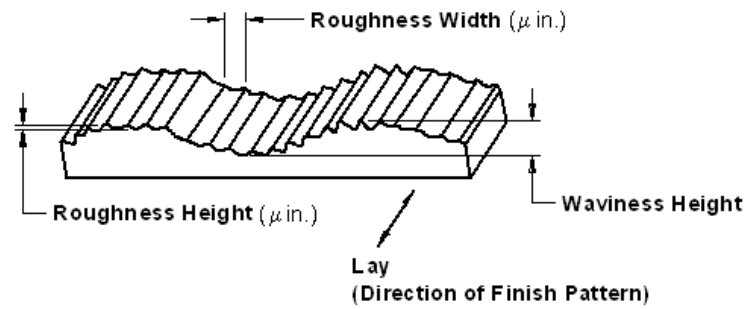

Figure 1.7: Surface Roughness pattern [69]

1.6.1. Surface texture: the pattern in which the real surface deviates from the nominal surface is known as surface texture. The pattern of deviation from the nominal surface may be random or repetitive which tells us about the type like roughness, waviness, flaws etc.

1.6.2. Real surface: The surface that is actually deviated from its nominal surface and classifies the surface form as roughness, waviness, flaws etc.

1.6.3. Roughness: Roughness is the result of the production process involved. It can be defined as the fine irregularities at regular intervals of the surface. Profile of roughness and waviness is shown in figure 1.7 [20].

1.6.4. Waviness: All the irregularities whose sampling length has greater spacing than roughness sampling length. The peak to valley distance is the waviness height measured in inches. The space between the successive peaks of waves or successive valleys of the wave is known as waviness width measured in inches.

1.6.5. Lay: the production method leads to a unique surface pattern. Lay actually denotes the direction of that surface pattern.

1.6.6. Lay Pattern: a lay pattern is an impression that is repetitive in nature and can be seen on the surface of the product. It represents the manufacturing operation used to make the product. Roughness is usually measured in a perpendicular direction to the lay. It is specified on the part by the product designer as the function of the part is affected by the directionality of the lay.

1.6.7. Flaws: flaws are sudden and unexpected interruption in the surface of the part [20].

1.6.8. Roughness sampling length: average surface roughness is determined over a particular length which is known as sampling length. The profile irregularities like roughness, waviness are differentiated on the basis of roughness sampling length [22].

1.6.9. Surface Roughness parameter

Surface roughness most commonly refers to the variation in the height of the surface relative to a reference plane. Roughness is generally the machined marks on a surface by the cutting tool.

- Peak is the portion above the average line in the direction of normal vector
- Valley is the portion below the average line in the direction of normal vector.
- Arithmetic average surface roughness (Ra) can be defined as the mean of the absolute values of the profile deviations from the mean line of the roughness profile. Ra is not sensitive to peak and valleys and does not differentiate between them.
- Rz is the sum of the maximum value of peak height and valley depth on the profile curve in a sampling length.
- Rt is the sum of the maximum value of peak height and valley depth on the profile curve but the entire length is considered in this evaluation [12].

2. The direction and magnitude of process variables is identified.
3. The number of experimental runs reduces to a great extent.
4. Used in design and development of engineering process.
5. Interaction among the input parameters is identified.
6. Optimization of the process performance is the main focus.

2.1 Taguchi method:

Conventional design methods are difficult and complex to use in actual practice as it requires a lot of experimental work and lot of time to conduct the complete experimental process when process parameters and the levels associated with them are increased. The problem to reduce the number of experiments and saving the time is solved by the orthogonal arrays based on taguchi methodology. It helps to study all the machining parameters and their effect efficiently in less amount of time [24]. Taguchi method is designed by Dr. Geinchi Taguchi, a quality management consultant from japan. The tool is very efficient for high quality manufacturing system designing. the major advantage of using taguchi design method is that the analysis of the process can be done in less time and also it helps to find significant factor. Taguchi method suggest an orthogonal array which is helpful in eliminating the requirement of performing large number of experimental runs and provides the solution with the help of experiments provided by designed orthogonal array. The three steps suggested by taguchi in product and process development are: 1) system design, 2) parameter design and 3) tolerance design. In system design scientific and engineering principals are used by the engineer to determine the fundamental configuration. The next step is parameter design where specific values for system parameters are determined. Tolerances for the parameters are determined in the tolerance design stage [25]. Taguchi's orthogonal array provides the set of experimental data (less number of experimental runs) and Taguchi's S/N ratio is the logarithmic function of desired output. The objective of using S/N ratio as a performance measurement is to develop products and processes insensitiveness to noise factors [26] The steps suggested by Taguchi are

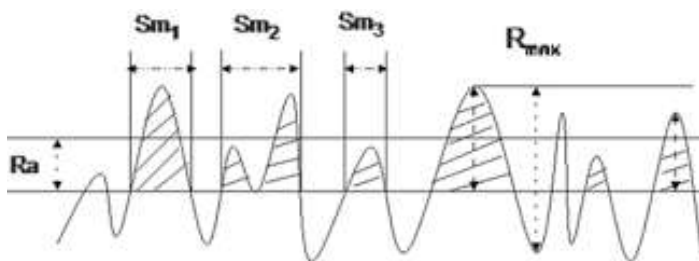

Figure 1.8: Surface Roughness parameters [70]

2. DOE (Design of experiment)

Deisgn of experiments is a statistical approach that helps to determine the relationship among factors and analyzing that how these factors are affecting a process and the output parameters of a particular process. A well planned and executed experiment is helpful in achieving the information about the effect of input parameters on response variables. It is seen in many experiments that certain factors are held constant and altering the other factor levels to see their effect on output [23].

1. Helpful in troubleshooting and development of the process.

System design:

This is the initial level step which involves creation from initial level and requires innovation capabilities.

Parameter design:

After establishing the concept various dimensions and design parameters values need to be set, it can be considered as the design phase of conventional engineering process [27].

Tolerance design:

After parameter design phase tolerance is provided for critical dimensions associated with process

Eight steps in Taguchi methodology:

Step 1: Identification of the main function, the failure mode of the process and side effects associated.

Step 2: Identification of the unwanted external factors also known as noise factors, conditions of testing and characteristics of quality.

Step 3: Identification of the objective function that is to be optimized.

Step 4: Identification of the input control parameters and its levels.

Step 5: Selection of orthogonal array for conducting experiments.

Step 6: Conducting the experiments according to orthogonal array.

Step 7: Analyze the predicted data at the set of input parameters suggested by optimization technique.

Step 8: Confirmation experiment is performed to justify the validation of optimization technique and plan the future scope [27].

2.3. Signal to noise ratio

In signal to noise ratio the desirable values are represented by the term signal, while the undesirable value are represented by noise. Signal to noise ratio tells us about the robustness of the parameter means it helps to choose the input parameters that minimizes the effect of external factors or noise factors on output. Therefore, the method to calculate the signal-to-noise ratio is dependent on the type of quality characteristics means it needs to be maximized we

use larger-the-better and if it needs to be minimized we use smaller-the-better also nominal-the-best formulation is also available.

The S/N ratio for larger-the better is

$$S/N = -10 \log_{10} \frac{1}{r} \sum_{i=1}^r \frac{1}{y^2} \quad 1.5$$

And for smaller-the-better characteristics can be expressed as:

$$S/N = -10 \log_{10} \frac{1}{r} \sum_{i=1}^r y^2 \quad 1.6$$

Where y_i = the mean of the measured values of the response variable of i^{th} experiment. r = number of experiments at a particular level of control factor in an orthogonal array. The negative sign is used to ensure that the largest value gives an optimum value for the response variable

2.4. S/N ratio and Main effect plots

Main effect plots are plotted using the data collected from the experiments and their signal to noise ratios with the help of MINITAB-17 software. Main effect plots for MRR and surface roughness shows the variation of output parameters with the change in values of input parameters. We always select highest value of the mean S/N ratio from graphs for optimization purpose without getting in to details of the criterion used before for calculation of S/N ratio of maximizing or minimizing the output parameters [24].

2.5. ANOVA and its Significance

ANOVA is a tool to analyze the data statistically and to detect any difference in the performance of the items that are tested in the group. ANOVA helps to determine whether a particular parameter is significantly affecting the quality characteristic. It helps to test all the major factors and their interactions by comparing the mean square against the estimated experimental errors at some confidence level (95%). In this analysis sum of squares and variance are calculated. A test known as F- test is performed at 95% confidence level to decide whether a factor is significantly affecting the process. Large F-value indicates the importance of the process parameter, larger the F-value higher is the impact of process parameter on quality characteristic [12, 17].

ANOVA estimates the significance of all the process parameters and their interaction. It tells us the percentage contribution of process parameters on the output quality

characteristic. The mean square is compared against the estimated experimental errors at specific confidence level. The total sum of squares from the total mean S/N ratio can be calculated as:

$$SSt = \sum n (\eta_i - m)^2$$

$$m = \frac{1}{n} \sum_{i=1}^n \eta_i$$

where n is the number of experiments in the orthogonal array, η_i is the S/N ratio for the i^{th} experiment and m is the overall mean of S/N ratios of n number of experiments.

- The adjusted sum of squares (Adj SS) for a factor is the measure of the amount of variation in the output that is dependent on a factor, given that all the other factors are present in the model already. Thus the value of the adjusted sum of squares is dependent on the factor order under the listed source.
- The adjusted mean squares (Adj MS) for a factor can be defined as the ratio of adjusted sum of squares to the degrees of freedom.
- The degrees of freedom used in the calculation of Adj MS are as follows:
- The degree of freedom for a factor can be calculated by subtracting one from the number of levels of that factor.
- The degree of freedom for the total sum of squares can be calculated by subtracting one from the number of rows of the design matrix.
- The degree of freedom for the error can be calculated as the difference between the degrees of freedom for the total sum of squares and the sum of degrees of freedom for the various factors.

F-Value is the statistic that is used to test whether the effect of a factor in the model is significant or not. F-value of a factor is calculated by dividing the mean square corresponding to that factor by the error mean square. F-value is used to determine the P-value using Euler integral of the first kind (Beta Function) and the cumulative distribution function (CDF). P-value is the probability and if P-value is less than or equal to the α -level selected, then the

factor has a significant effect on the response and if P-value is larger than α -level selected, the effect is not significant [22].

Percentage contribution (%) is defined as the significance rate of the process parameters on the response variables and it is calculated as:

$$\text{Percentage contribution} = \frac{\text{Adj. SS}}{\text{total}} \times 100 \quad (1.9)$$

In the present study, ANOVA was performed at a confidence level of 95% i.e. $\alpha = 5\%$.

2.6. Grey Relational technique

Grey relational technique is a method of converting two or more quality parameters in to single quality parameter so that multi objective can be converted in to a single objective quality parameter and optimization technique like Taguchi used for single objective optimization can be utilized. This is done by obtaining grey relational grade from grey relational analysis. It is characterized by less data and multifactor analysis, where these two characteristics can overcome the disadvantage of statistical regression analysis. Grey relational grade is used as a performance characteristic in this single objective optimization technique

Steps in grey relational technique:-

1. Normalization of S/N ratios
2. Determination Deviation Sequence
3. Determination of Grey Relational Coefficient
4. Determination of Grey Relational Grade (GRG)
5. Providing Rank according to GRG

2.7. Conclusions

CNC machining operation is a very efficient process for turning purpose. It can be controlled as per the user requirement with the help of CNC part program. The desired input parameters can be feed in to the CNC machine and their effect on output can be seen. It is a highly reliable machine tool and the optimization techniques like taguchi helps to save time and resources requires for conducting the experiment and provide robust design parameters. ANOVA is another statistical tool used in the optimization process that helps to determine significant input parameters and their contribution on output. Main effect plot are plotted with the help of S/N ratio and input parameters that shows the variation in S/N ratio of output on changing the input using MINITAB-17 software.. The grey relational technique used in the study to convert multi objective output like material removal rate and surface roughness in to single objective

parameter grey relational grade is very effective and provides confirmation of predicted and experimental values which shows that the complete optimization process is systematic and well conducted.

References

- [1] Pawade Raju, Shrihari and Joshi Suhas, S., 2011, "Objective Optimization of Surface Roughness and Cutting Forces in High Speed Turning of Inconel 718 using Taguchi Grey Relational Analysis(TGRA)", *Int J AdvManufTechnol*, vol.56: pp. 47–62
- [2] D'Addona and Teti, D.M., 2013, "Genetic Algorithm-based Optimization of Cutting Parameters in Turning Processes", *Procedia CIRP*, Vol. 7, 2013, ISSN 22128271: pp323-328
- [3] KaladharM., SubbaiahK. Venkata, RaoCh. Srinivasa and RaoK. Narayana,2010 "Optimization ofProcess Parameters in Turning of AISI202 Austenitic Stainless Steel", *ARPN Journal of Engineering and Applied Sciences*, VOL. 5, NO. 9, pp. 79-87
- [4] Feng, C.X. and Wang X,2002,"Development of Empirical models for Surface Roughness Prediction in FinishTurning", *International Journal of Advanced Manufacturing Technology*;Vol. 20, pp.348-356.
- [5] Lambert B.K., 1983, "Determination of Metal Removal Rate with Surface Finish Restriction", *Carbide and Tool Journal*, vol. May – June, pp. 16-19
- [6] Ho SY , Lee KC, Chen SS, Ho SJ, 2002, "Accurate Modeling Prediction of Surface Roughness by Computer Vision in Turning Operation using an AdaptiveNeuro-Fuzzy Inference System", *Int J Mach Tools Manuf.*; vol. 42, pp. 1441-1446.
- [7] Malakooti B. and Raman V,2000, "An Interactive Multi-Objective artificial Neural Network Approach for Machine Setup optimization", *Journal of Intelligent Manufacturing*, Vol. 111, pp 41-50.
- [8] Rasch and Roistadas,1971 "Series of finish Turning Tests under variation ofParameters : Material quality , Tool quality , Tool nose radius , Feed speed and Cutting time", *Journal of material processing technology*, Vol-132, pp. 203-214.
- [9] Yang, W.H., Tarn, Y.S., 1998, "Design optimization of cutting parameters for turning operations based on the Taguchi method", *Journal of Materials Processing Technology*, Vol. 84, pp. 122-129.
- [10] Kopac, J., M. Bahor and M. Sokovic, 2002, Optimal machining parameters for achieving the desired surface roughness in fine turning of cold preformed steel work pieces. *Mach. Tools Manufact.*, 42: 707-716. DOI: 10.1016/S0890-6955(01)00163- 8
- [11] TugrulÖzel, A. EstevesCorreia, J. Paulo Davim, 2009, Neural network process modelling for turning of steel parts using conventional and wiper inserts, *Int. J. Materials and Product Technology*, Vol. 35, Nos. 1/2
- [12] AhmetHascalik and UlasCavdas, September 2008,"Optimization of Turning Parameters for Surface Roughness and Tool life based on the Taguchi Method",*The International Journal of Advanced Manufacturing Technology*, Volume 38, Issue 9-10, pp. 896-903
- [13] Tzeng, Chong-Jyh, Lin, Yu-Hsin, Yang, Yung-Kuang and Jeng, Ming-Chang,19March 2009,"Optimization of Turning Operations with Multiple Performance Characteristics using the Taguchi Method and Grey Relational Analysis", *Journal of Materials Processing Technology*, Volume 209, Issue 6, , Pages 2753–2759
- [14] Gupta, Anil; Singh, Hari and Aggarwal, Aman, June 2011, "Taguchi-Fuzzy Multi output optimization (MOO) in high speed CNC turning of AISI P-20 tool steel", *Expert Systems with Applications*, Volume 38, Issue 6, Pages 6822–6828
- [15] KaladharM., SubbaiahK. Venkata, RaoCh. Srinivasa and Rao K. Narayana,"Optimization of Process Parameters in Turning of AISI Austenitic Stainless Steel",*Asian Research Publishing Network (ARPN)*
- [16] Singh, T.P Singh, J, Madan. J and Kaur G, 2010 , Effect of cutting tool Parameters on surface roughness, *International journal of Mechanical engineering and Technology (IJMET)*, ISSN 0976-6340, ISSN 0976-6359 (online) Volume 1, Number 1. PP.182-189.
- [17] AggarwalAman, SinghHari, Kumar Pradeepand SinghManmohan,2008 "Optimizing Power Consumptionfor CNC Turned Parts using Response Surface Methodology and Taguchi's technique - A comparativeanalysis", *Elsevier Journal, Journal of materials processing technology*, pp. 373–384
- [18] AggarwalAman and SinghHari, December 2005, "Optimisation of Machining Techniques-a retrospective and literaturereview", *Sadhana*, Vol. 30, Part 6., pp. 699–711
- [19] AgrawalAnupam, GoelSaurav, RashidWaleed Bin and PriceMark,May 2015,"Prediction of Surface Roughnessduring Hard Turning of AISI 4340 steel (69 HRC)",*Applied Soft Computing*, Volume 30,Pages 279-286, ISSN 1568-4946
- [20] ChangChung-Shin, TsaiGwo-Chung,10 November 2003,"A Force Model of Turning Stainless Steel with Worn Tools havingNose Radius", *Journal of Materials Processing Technology*, Volume 142, Issue 1, ,Pages 112-130, ISSN 0924-0136
- [21] A. Y. Mustafa, T. Ali,"Determination and optimization of the effect of cutting parameters and work piece length on the geometric tolerances and surface roughness in turning operation", *International Journal of the Physical Sciences*, 6(5), 2011, 1074-1084
- [22] SuleymanNeseli, SuleymanYaldiz, ErolTurkes, "Optimization of tool geometry parameters for turning operations based on the response surface methodology", *Measurement*, Vol. 44 (2011), 580-587.
- [23] Kaisan Muhammad Usman, "Effects of tool rake angle on tool life in turning tool,"*International journal of scientific & engineering research*,vol.3, 4. April. 2012, ISSN. 2229-5518.
- [24] Yang, W.H. and Tarn, Y.S. (1998) "design optimization of cutting parameters for turning operations based on the taguchi method", *journal of materials processing and technology*, vol 82, pp 122-129
- [25] Lee SH, Saito Y, Sakai T, Utsunomiya H (2002) "Microstructuresand mechanical properties of 6061 aluminum alloy processed by accumulative roll-bonding", *Mater Sci Eng A* 325(12):228–235
- [26] Barletta M (2006) "A new technology in surface finishing: fluidizedbed machining (FBM) of aluminium alloys", *J Mater Process Technol*, vol.173(2), pp-157–165
- [27] Ng CK, Melkote SN, Rahman M, Senthil Kumar A (2006) "Experimental study of micro- and nano-scale cutting of aluminum 7075-T6", *Int J Mach Tools Manuf* 46(9):929–936