

# We are IntechOpen, the world's leading publisher of Open Access books Built by scientists, for scientists

6,100

Open access books available

167,000

International authors and editors

185M

Downloads

Our authors are among the

154

Countries delivered to

TOP 1%

most cited scientists

12.2%

Contributors from top 500 universities



WEB OF SCIENCE™

Selection of our books indexed in the Book Citation Index  
in Web of Science™ Core Collection (BKCI)

Interested in publishing with us?  
Contact [book.department@intechopen.com](mailto:book.department@intechopen.com)

Numbers displayed above are based on latest data collected.  
For more information visit [www.intechopen.com](http://www.intechopen.com)



Chapter

# Fatigue Behavior of Reinforced Welded Hand-Holes in Aluminum Light Poles with a Change in Detail Geometry

*Cameron R. Rusnak and Craig C. Menzemer*

## Abstract

Welded aluminum light poles often contain hand-holes. These hand-holes are used to give access for electrical wiring installation and maintenance purposes. Wind load may cause light poles to be loaded in a cyclic manner. This cyclic loading can cause localized fatigue cracking around the hand-hole. Fatigue failure around hand-holes has been observed in the field, but studies surrounding the resistance of the hand-holes are few and far between. This study included four-point bending fatigue tests on welded aluminum poles containing hand-holes. Eight welded aluminum specimens, each with two hand-holes, were tested in fatigue. These 16 details were loaded at the same stress range. Each specimen had a slightly different geometry or treatment applied to the hand hole. These different details mimicked traditional reinforced hand holes, similar to those evaluated in previous studies. Changes in the treatment and/or geometry included milling the inside of hole, milling the inside of the hole as well as the cast insert prior to welding, and milling the cast insert itself prior to welding. Among the 16 details tested, 15 failed as a result of fatigue cracking. It was found that specimen failure would originate in the throat of the fillet weld and then proceeded to propagate into the reinforcement ring/casting. A finite element analysis was used in addition to the experimental study.

**Keywords:** fatigue test, static test, welded aluminum hand-hole details, design S-N curve, high cycle fatigue

## 1. Introduction

The illumination of outdoor recreational areas, roadways, sidewalks, and parking lots is of the utmost importance at night. To illuminate these areas, different forms of poles are used to support an overhead light fixture. Typically, the best choice of material for these poles is aluminum due to its corrosion resistance, lightweight, ease of joining, ease of handling and a high strength to weight ratio. Wind loads are often the prominent force that is applied to poles and can cause localized fatigue cracking at different areas of interest [1, 2].

Modern fatigue design utilizes a lower bound S-N curve that is typically established from full-scale test data. Specimens usually contain some sort of stress concentration around a point or detail of interest. Stress concentrations usually occur around connections, cutouts, keyways, copes as well as other locations [3, 4]. One possible way to improve fatigue life would be to reduce the impact of these stress concentrations by minimizing abrupt changes in cross-section. This may be done by providing “smooth” transitions between parts. The fatigue behavior of electrical access hand-holes in welded aluminum light poles is largely unknown. The majority of existing data that has been developed was collected from full-scale welded steel poles [5]. In this study, points of interests where these stress concentrations occur are between the pole itself and the welded hand-holes.

NCHRP report number 176 contains results from experiments conducted at Lehigh University on both unreinforced and reinforced hand-holes in welded steel structures. During this experiment, 13 of the specimens contained some form of hand-hole. Different geometries were evaluated during this study. Over the course of the experiments, none of the hand-holes cracked. To provide an estimate of the stress concentration around the hand-holes, finite element models were created. AASHTO Category E’ was recommended [6].

Observations have confirmed the existence of fatigue cracking associated with different hand-holes in the field. NCHRP report number 469 describes fatigue cracks found on welded steel structures near and around the hand-holes in several states. These states included New York, California, New Mexico and Minnesota [7]. In Iowa, there was a failure in a high-mast welded pole that was found to contain cracking around the hand-hole. This failure prompted further investigation into other poles and towers, in which multiple contained some form of fatigue cracking. Fatigue cracking was found in welded aluminum light poles mounted on the Mullica River Bridge after a violent storm in 2011 [8]. **Figure 1** depicts a fatigue failure associated with a hand-hole on an aluminum light pole that occurred in the field.



**Figure 1.**  
*Fatigue crack in welded aluminum light pole hand-hole.*

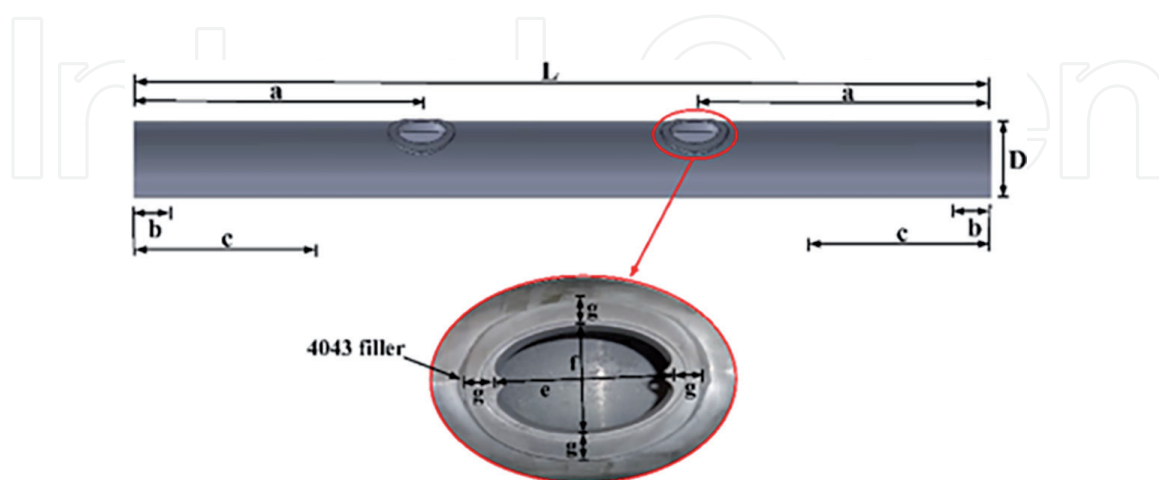
Twenty light poles were tested in bending fatigue at the University of Akron. Static tests were conducted in addition to the fatigue tests in an attempt to gain a better insight into how the strain is distributed around the handhole. The results from this study concluded that the hand-hole fatigue test data fell above category D and E design S-N curves [9]. In addition, the University of Akron performed a study on the effect of a change in the diameter of the specimens, from 10 in to 8 in. It was found that this change had a small, but slightly beneficial effect on fatigue life [9].

In comparison to the previous research conducted on the fatigue behavior of welded aluminum light poles, the novelty of this study comes from examination of changes to the welded hand-hole detail that have not been explored. Previous studies [9–11] utilized an identical weld detail but with different diameter specimens. The specimens included typical 10in diameter as well as 8in diameter poles loaded in four point bending. The change in the detail geometry could yield a better fatigue life that could be used in the field. During this study, eight light pole specimens, each with a different hand-hole detail treatment or geometry, were tested in fatigue. Finite element models were developed to improve the understanding of the stress field around the hand-hole.

## 2. Experiments

### 2.1 Pole geometry and material properties

Eight aluminum specimens were tested under cyclic loading to examine the behavior of the modified reinforced hand-hole details (**Figure 2**). Each of the specimens consisted of a 25.4 cm (10 in) diameter extruded aluminum alloy tube with a 0.635 cm (1/4 in) thick wall. Each of these 6063 aluminum alloy tubes had two hand-holes with reinforcement welded in place using a GMAW (Gas Metal Arc Welding) process with 4043 filler (**Figure 2**) [3, 12]. Each specimen was 3.66 m (144 in) in length, with the hand-holes paced 1.37 m (54 in) in from each end respectively. Support rollers for the specimens were inserted 15.2 cm (6 in) from either end.



$$L = 3.66 \text{ m (144 in.)}; D = 25.4 \text{ cm (10 in.)}; a = 1.37 \text{ m (54 in.)}; b = 15.2 \text{ cm (6 in.)};$$

**Figure 2.**  
*The geometry of a welded aluminum hand-hole detail in four-point fatigue testing.*

Part Name	Alloy	Tensile Yield Strength	Ultimate Tensile Strength
Tube	6063-T6	31 ksi (213.7 Mpa)	35 ksi (241.3 Mpa)
Fillet Welding	4043	N/A	29.2 ksi (201.3 Mpa)
hand-hole	A356-T6	20 ksi (137.9 Mpa)	30 ksi (206.8 Mpa)

**Table 1.**  
*Mechanical properties of the aluminum hand-hole tubes.*

**Table 1** summarizes the minimum mechanical properties of the welded aluminum hand-hole specimens [3, 12].

## 2.2 Geometry changes to reinforcement

Each of the eight poles contained two hand holes and each sample a different hand-hole treatment or modified geometry. The first set of two consisted of the same welded hand-hole detail used in the field. These hand-holes measured 150 mm (6 in) in the longitudinal direction and 100 mm (4 in) in the transverse direction. The other groups of poles had holes that were milled around the inside before welding, utilized reinforcement castings that were milled the outside before welding or a combination of the two. In the milling of both the hole and cast insert, only about a 6.25 mm (¼ in) of material was removed. As the hand-holes are cut with a plasma process, removal of material around the perimeter of the hole is intended to eliminate any hot – short cracking.

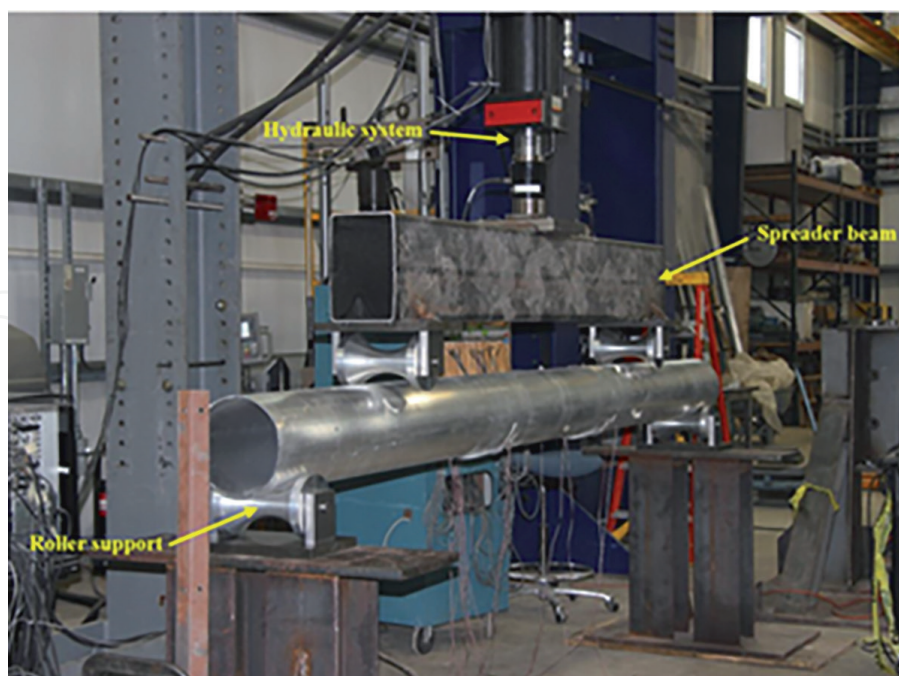
## 2.3 Fatigue tests

The fatigue setup that was used in the lab may be seen in **Figure 3**. A control system with a 245 KN (55 kip) MTS servo-hydraulic actuator was utilized to apply load to the specimens. A structural load frame capable of support 1335 KN (300 kips) was used to mount the actuator. The specimens were loaded by a spreader beam with supports that were rollers machined to fit the profile of the tube.

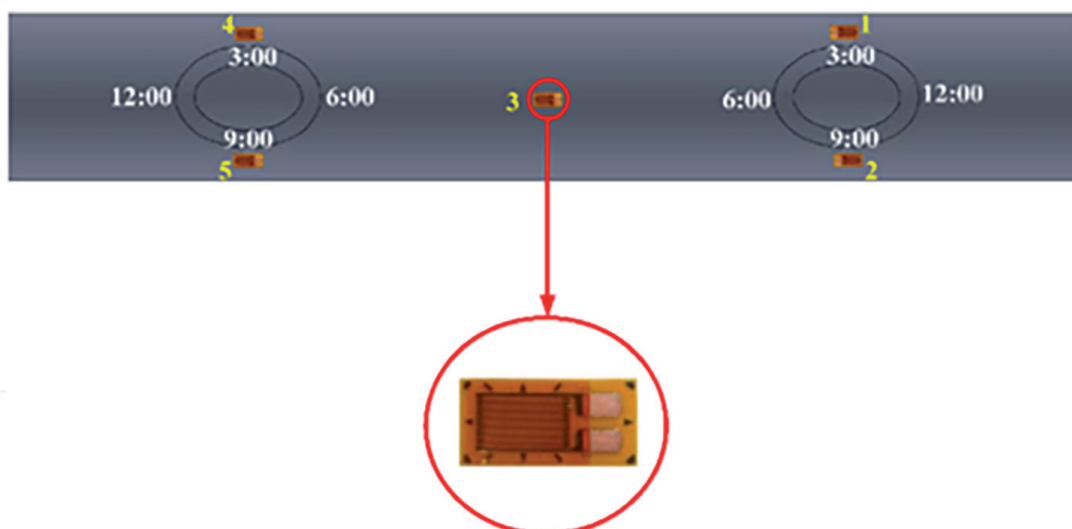
Strain gages were used to monitor strains in the specimens. They were mounted around the hand-holes using adhesive. Tests were conducted in load control. The typical location of the strain gages on the specimen may be seen in **Figure 4**. Strain gage placement was the same as the older study conducted and was taken from [9]. Strain gage resistance was 350 ohms and were 3.175 mm (⅛ in) in. Strains were recorded every two hours, intermittently for 10 second using a Micro-Measurements System 8000 data acquisition device.

Specimens had their hand-hole openings facing “downward” during testing. This was to ensure that they were in tension. Failure occurred when the maximum target load on the specimen could not be supported. Not being able to support the target load is an indication that cracking occurred. When a displacement over 10% of the target was realized, the test was shut down. This 10% displacement was set in order to ensure that the specimens would not fail catastrophically, and the damaged detail could be repaired. This repair was in the form of a moment clamp placed over the failed hand-hole. There was a single case where this moment clamp was unable to repair the specimen to continue testing.

Eight poles, each with two hand-holes, were tested at a nominal stress range of 5.4 ksi (37.4 Mpa). Each of these poles were loaded between 227 kg (500 lbs) and 3402 kg (7500 lbs) to provide a direct comparison between all tests. Strain gages were placed



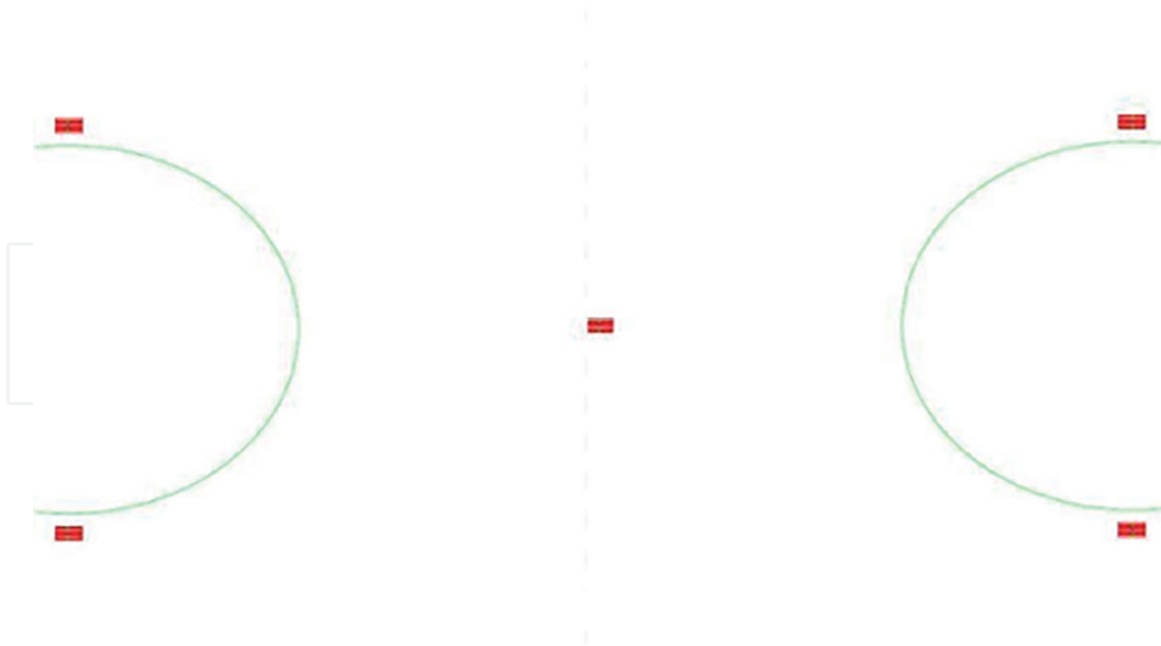
**Figure 3.**  
*Fatigue test set-up of welded aluminum hand-hole details.*



**Figure 4.**  
*Typical strain gage location and position around the hand-holes.*

as shown in **Figure 5** and installed on the surface of the tube adjacent to the fillet weld that joins the cast hand-hole to the tube. Strain gage placement was the same as the older study and was taken from [9]. A strain gage was placed at the 3 and 9 o'clock positions respectively, with the addition of a gage in the middle of the specimen. The center of the gage was placed within 2 ~ 3 times the tube thickness away from the welding throat. The strain gages were connected to the data acquisition system to measure the nominal stress ranges.

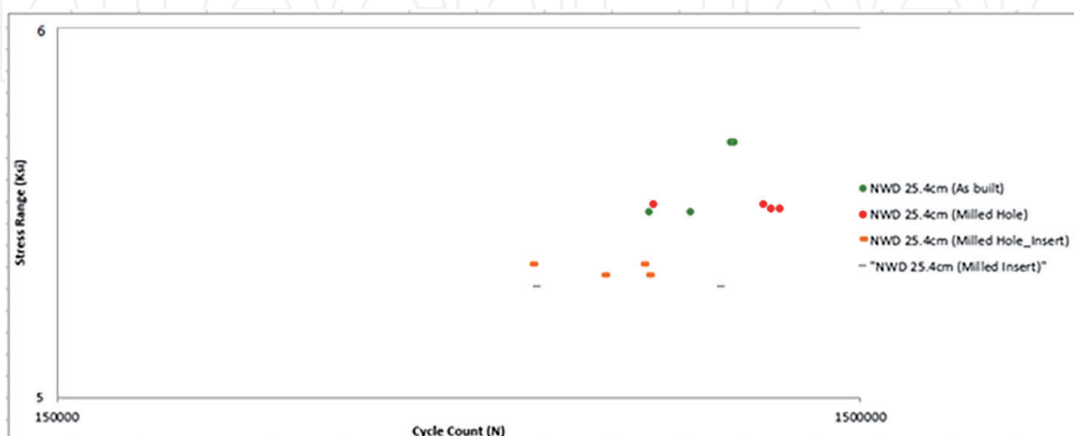
All of the specimens were cycled at 2 Hz and tested around the clock. Visual inspections of the hand-holes were conducted several times daily. Of the 16 hand-hole details tested, 15 failed.



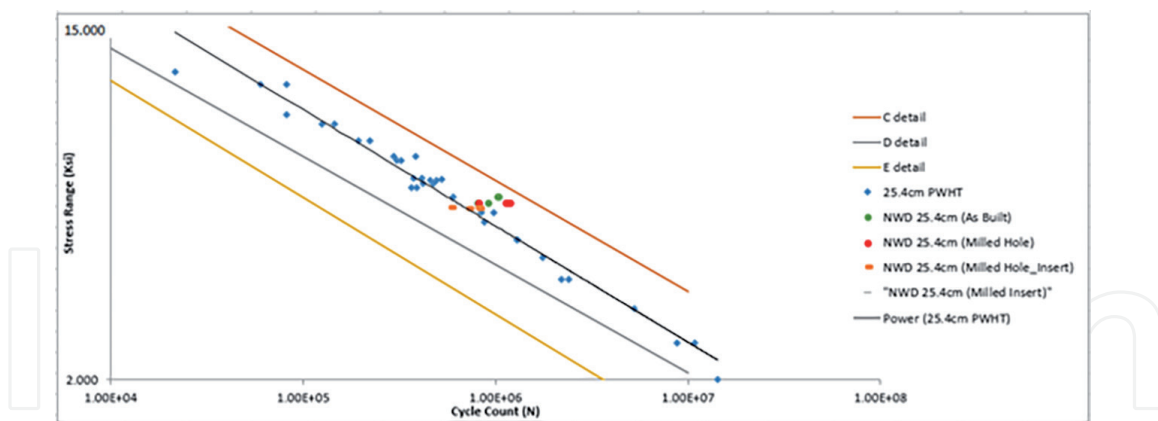
**Figure 5.**  
The position of strain gages installed around a hand-hole.

The data shown in **Figure 6** reveals that changes to the weld detail do not have a drastic effect on fatigue life. In fact, some of the changes appeared to have a negative effect on the fatigue life. This was most prevalent in the milling of the cast insert. The only test that appeared to have any positive effect was when the hole itself was milled. In this case, the fatigue life was increased slightly. **Figure 7** shows the compilation of previous data compared to the change in details [11].

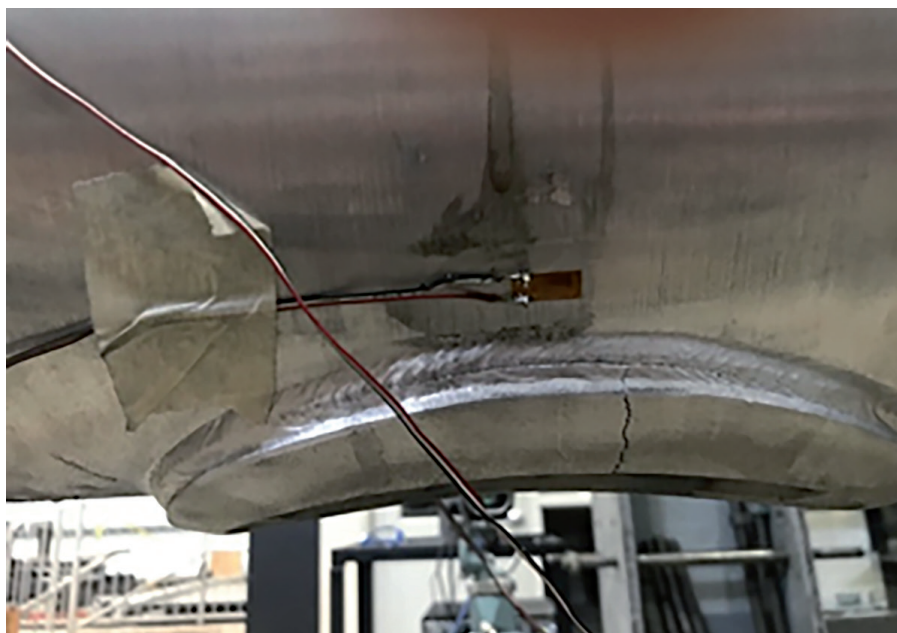
During testing, cracks were first observed in the throat of the fillet weld that joins the tube to the reinforcement ring. These cracks were first observed along the minor axis of the hand-hole at either the 3:00 or 9:00 position in Ref. to a clock. A sample of one of these cracks may be seen in **Figure 8**. These cracks would normally start at the weld root and propagate through the throat of the weld and then progress around the handhole. **Figure 9** shows an example of the crack surface after failure. Note that this



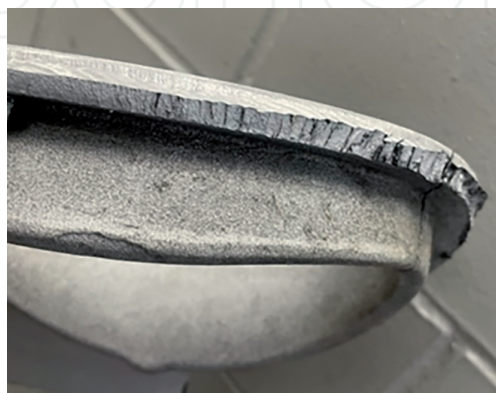
**Figure 6.**  
Fatigue test results of new weld hand-hole details.



**Figure 7.**  
*New weld detail vs. old 10in data.*

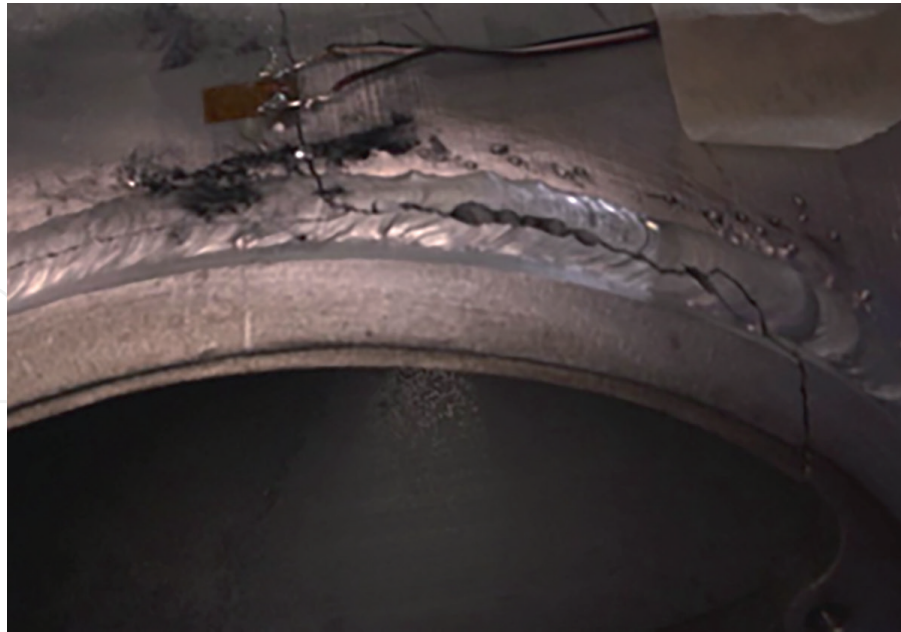


**Figure 8.**  
*Fatigue crack through weld throat between reinforcement and tube.*



**Figure 9.**  
*Jagged crack edge.*





**Figure 10.**  
*Typical final failure of hand-hole details.*

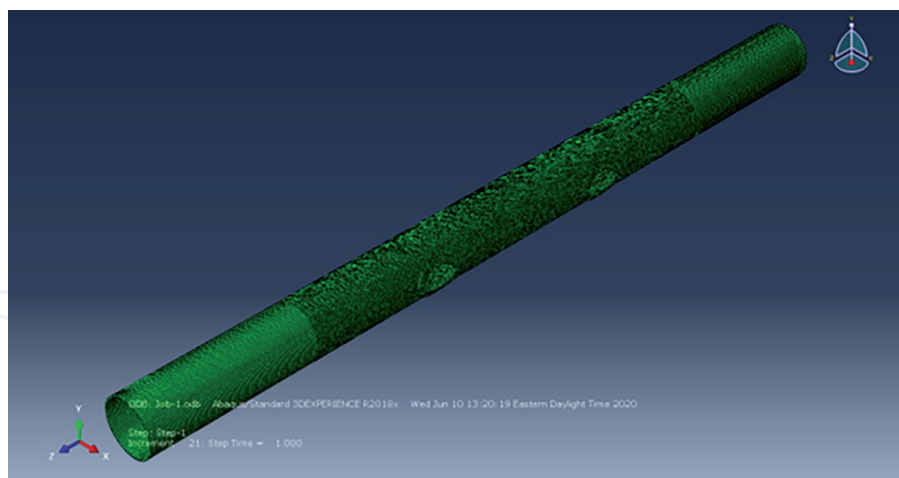
is similar to that of a previous study conducted at the University of Akron [10]. The edges of the jagged surface appear to coincide with the weld bead ripples.

Final failure typically occurred as the crack progressed through the cast insert near either the 11:00 or 5:00 position (**Figure 10**). In these cases, the fatigue cracks spent most of the cyclic life while small. In every case there was a definite transition from the time of the development and propagation of visible fatigue cracks within the fillet weld throat to the final failure. In most cases, cracks would develop and progress around the hand-hole. At this point, they would appear to stop, and only after a significant number of load cycles were applied, would failure occur.

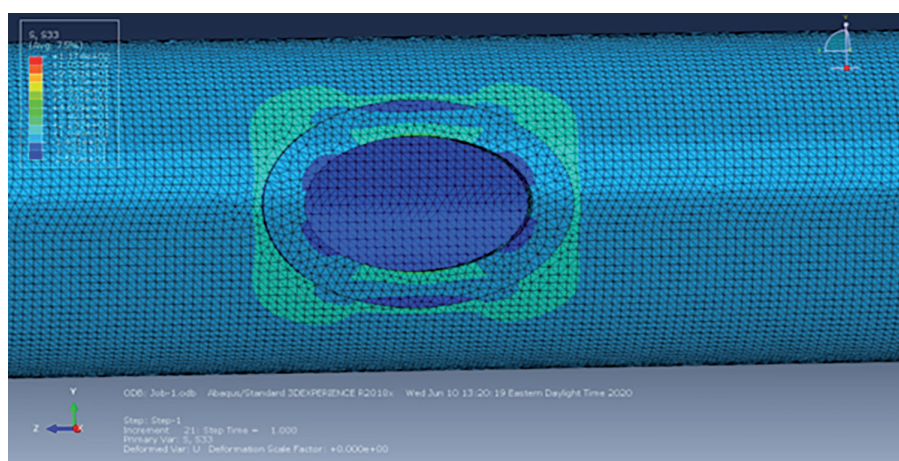
### 3. Finite element modeling

A finite element (FE) model was created for the four-point bending specimen in an attempt to understand the stress distribution adjacent to the hand-holes. This model was constructed to be identical to the weld detail and geometry of the specimens. The model also included an initial imperfection in the detail along the line where cracking would first be observed. The purpose was to determine how a crack through the throat of the fillet weld would affect the stress distribution. Local stresses were mesh dependent for this study. Finer mesh sizes often increase the stresses local to important geometric details, whereas a coarse mesh often results in a reduction in local stress. The model as a whole consisted of 633,324 nodes with 346,747 elements. Each consisted of a mix of both hexahedral and tetrahedral element types. **Figure 11** depicts the mesh and model as a whole.

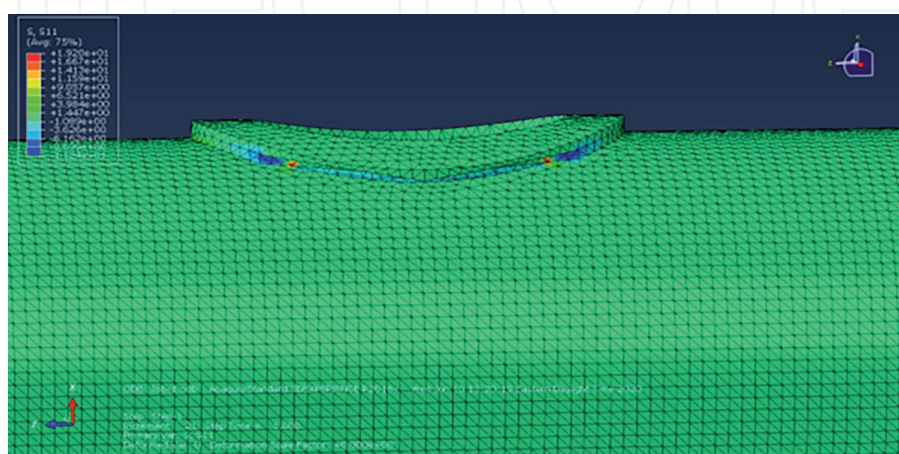
Stress “hot spots” indicate where fatigue cracking is likely to develop. **Figure 12** shows a longitudinal stress map along the “Z” axis. Under bending, longitudinal stress developed and the distribution, sense, and magnitude are affected by the presence of the hand-hole detail. This is shown in **Figure 12** with the shade of blue being a relatively low stress while elevated stress (**Figure 11**) is green. Hot spots appear alongside most of the hand-hole, maximum values between the 10:00 and 2:00 positions,



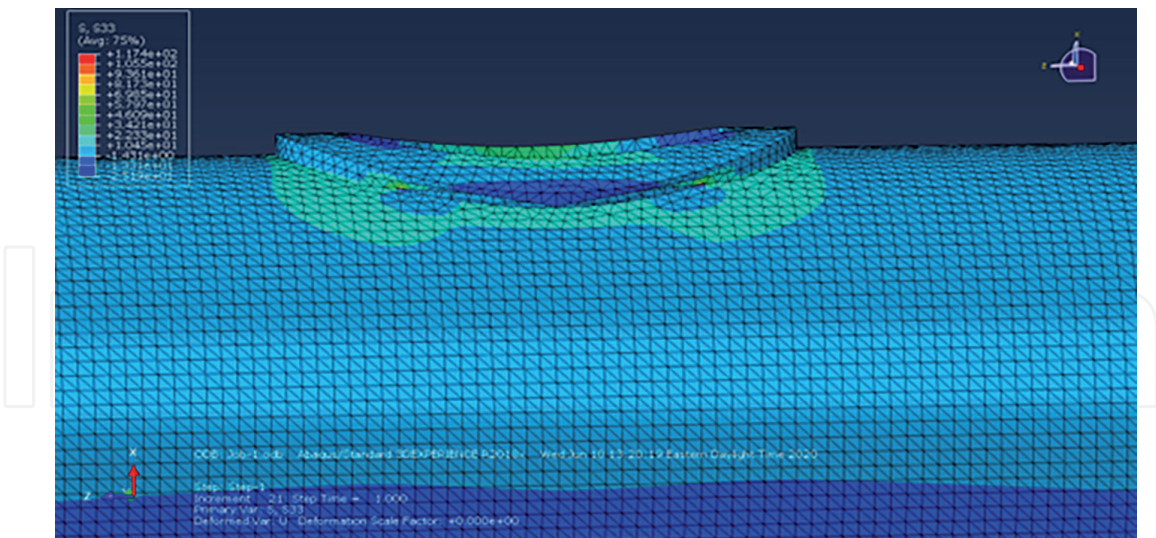
**Figure 11.**  
Overall model.



**Figure 12.**  
Contours of longitudinal stresses around the hand-holes.



**Figure 13.**  
Stress concentration X direction.



**Figure 14.**  
Stress concentration Z direction.

as well as between the 5:00 and 7:00, indicated by a lighter shade of blue. Elevated stresses are apparent on the inside edge of the reinforcement. Stresses are larger near the junction of the inside and outside legs of the reinforcement [9]. This makes sense because, as the tube bends, the cast reinforcement attempts to elongate on the tension side. This stretches the reinforcement insert and results in transverse bending.

**Figures 13 and 14** show how a crack within the detail effects the stress hot spots. In **Figure 13**, to be precise, the stress is along the “X” axis and shows that the highest concentration of stress is located at the “end” of the crack with a red color. **Figure 14** shows this exact same phenomenon along the “Z” axis.

#### 4. Conclusions

Fatigue tests conducted on aluminum light pole samples containing a variety of welded hand-hole details revealed that there were no significant increases in the fatigue life with changes in the treatment of the hand holes or changes in the detail geometry. A total of 8 tests were conducted resulting in 15 data points, all subjected to nearly the same stress range and loading rate. Fatigue test results indicated that while there was some deviation in the results when plotted by itself, the changes made did not have a drastic effect on the fatigue life of the specimens. The finite element models show how an initial crack effects the stress concentration around the handhole. From the results, it can be seen how the stress “pools” at the location where that initial cracks were observed. This was consistent with the results in the lab.

#### Acknowledgements

The authors would like to convey their gratitude to HAPCO Company for manufacturing the samples for experiments and providing funding for the study.

IntechOpen

IntechOpen


### **Author details**

Cameron R. Rusnak\* and Craig C. Menzemer  
Department of Civil Engineering, The University of Akron, Auburn Science and  
Engineering Center (ASEC 210), Akron, OH, United States

\*Address all correspondence to: [crr44@zips.uakron.edu](mailto:crr44@zips.uakron.edu)

### **IntechOpen**

---

© 2022 The Author(s). Licensee IntechOpen. This chapter is distributed under the terms of the Creative Commons Attribution License (<http://creativecommons.org/licenses/by/3.0>), which permits unrestricted use, distribution, and reproduction in any medium, provided the original work is properly cited. 

## References

- [1] Murthy MVV, Rao KP, Rao AK. On stresses around an arbitrarily oriented crack in a cylindrical shell. *International Journal of Solids and Structures*. 1974;**1974**(10):1243-1269
- [2] Durelli AJ, Parks VJ, Feng HC. Stresses around an elliptical hole in a finite plate subjected to axial loading. *Journal of Applied Mechanics*. 1966;**1966**(33):192-195
- [3] Aluminum Design Manual. Specification for Aluminum Structures. Arlington, VA, USA: The Aluminum Association; 2010
- [4] Fisher JW, Kulak GL, Smith IFC. A Fatigue Primer for Structural Engineers. National Steel Bridge Alliance: AISC; 1998
- [5] AASHTO (American Association of State Highway and Transportation Officials). Standard Specifications for Structural Supports for Highway Signs, Luminaires and Traffic Signals (LRFDLTS-1). Washington, DC, USA; 2015
- [6] Roy S, Park YC, Sause R, Fisher JW, Kaufmann EJ. Cost-Effective Connection Details for Highway Sign, Luminaire, and Traffic Signal Structures. NCHRP 10-70 Web-Only Doc. 176. Washington, DC, USA: Transportation Research Board; 2011
- [7] Dexter RJ, Ricker NJ. Fatigue-Resistant Design of Cantilevered Signal, Sign, and Light Supports, NCHRP Rep 469. Minneapolis, MN, USA: Univ of Minnesota; 2002
- [8] Menzemer C. Examination of several Mullica river bridge light poles, corresponding to J. Bowman, Hapco, USA. 2012
- [9] Daneshkhah AR, Schlatter CR, Rusnak CR, Menzemer CC. 2019 Fatigue behavior of reinforced welded hand-holes in aluminum light poles
- [10] Rusnak CR. Fatigue Behavior in Reinforced Electrical Access Holes in Aluminum Light Pole Support Structures. Master's thesis. Akron, OH, USA: the University of Akron; 2019
- [11] Schlatter CR. Fatigue Behavior of the Reinforced Electrical Access Hole in Aluminum Light Pole Structures. Master's thesis. Akron, OH, USA: the University of Akron; 2017
- [12] Hilty E, Menzemer C, Manigandan K, Srivatsan T. Influence of welding and heat treatment on microstructure, properties and fracture behavior of a wrought aluminum alloy. *Emergency Mater Research*. 2014;**2014**(3):230-242