

PAIRS IN INVOLUTION

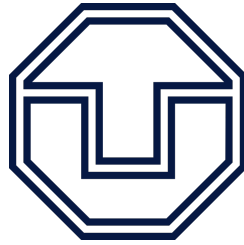

DISSERTATION

zur Erlangung des Grades

Doctor rerum naturalium
(Dr. rer. nat.)

vorgelegt dem Bereich

Mathematik und Naturwissenschaften
der
Technischen Universität Dresden

von

Sebastian Halbig

geboren am 12.09.1992 in Nürnberg

Eingereicht am: 05.05.2022

Tag der Verteidigung: 15.07.2022

ERSTGUTACHTER: Prof. Dr. Ulrich Krähmer

ZWEITGUTACHTER: Prof. Dr. Christoph Schweigert

„Wenn man ein 0:2 kassiert, dann ist ein 1:1 nicht mehr möglich.“ – Satz des Pythagoras

Mark-Uwe Kling – Das Känguru Manifest

For Rebecca and my family.

First and foremost, I would like to thank my supervisor Prof. Dr. Ulrich Krähler for all of his support, the many discussions we had and have and all the ideas he provided me with. Also, this dissertation would not exist without my family and my girlfriend Rebecca who were constantly by my side and never shy of lending me a helping hand. Lastly, I want to take this opportunity to thank all my friends in and outside of Dresden. You are the reason the past years were the enjoyable adventure they turned out to be.

ABSTRACT

Pairs in involution are a Hopf algebraic structure with applications to category theory, cyclic homology and knot theory. In the present dissertation we will answer the question whether every finite-dimensional Hopf algebra admits such pairs, construct and investigate their categorical analogues, and develop, based on our previous findings, the theory of pairs in involutions for Hopf monads.



Hopf algebras are the central structure on which the dissertation at hand is based. They can roughly be described as generalisations of groups with a comultiplication taking the role of the diagonal map and a non-necessarily involutive operator, called an antipode, replacing taking inverses. For any Hopf algebra a pair in involution consists of an element living in a canonical subgroup of that algebra together with a character such that this pair implements the square of the antipode of the Hopf algebra. These pairs give rise to trace-like operations on certain morphism spaces over Hopf algebras. However, in general the cyclicity condition holds only up to scalar multiplication. Pairs in involution for which that scalar is one are called modular. They take the role of one-dimensional coefficients in Hopf-cyclic cohomology as defined by Connes and Moscovici. Amongst other things, this application prompted Hajac to ask whether every finite-dimensional Hopf algebra admits a (modular) pair in involution.

To answer this question, we consider a class of finite-dimensional Hopf algebras, called generalised Taft algebras. These arise from the theory of (small) quantum groups and can be thought of as ‘quantum planes’. For a generalised Taft algebra (modular) pairs in involution correspond to solutions of a system of linear Diophantine equations whose coefficients are derived from the defining structure parameters of the Hopf algebra. One of our main results is stating necessary and sufficient criteria for the existence of solutions to these systems of equations. From this we can draw two conclusions. First, there are finite-dimensional Hopf algebras that have pairs in involution but these cannot satisfy the modularity condition. Second, there are, moreover, finite-dimensional Hopf algebras without such pairs altogether.

A more conceptual perspective on pairs in involution is given by the means of representation theory. An essential step in establishing this connection is the following observation: the modules over a Hopf algebra admit the categorical analogue of a monoid structure. That is, there exists a multiplication, given by the tensor product, and a unit, the trivial module, such that associativity and unitality hold weakly. This analogy suggests that one can furthermore consider the centre of this ‘monoid’. As is typical in categorification, it is not required that the tensor product is strictly commutative in the centre. Rather, one considers isomorphisms, so-called half-braidings, which revert the order of the ‘multiplication’. In the case of Hopf algebras, the centre construction is intimately related to the Yang–Baxter equation. In his seminal work on quantum groups¹, Drinfeld obtained canonical

¹V. G. Drinfeld. Quantum groups. Proc. Int. Congr. Math., 1987.

solutions to this equation by associating to any finite-dimensional Hopf algebra its Drinfeld double. Its modules can be identified with the so-called Yetter–Drinfeld modules. These in turn are equivalent to the centre of the category of modules of the underlying Hopf algebra. Hajac, Khalkhali, Rangipour and Sommerhäuser observed that a slight variation in the definition of these modules leads to a category, which they called the anti-Yetter–Drinfeld modules. It serves as a rich source of coefficients for Hopf-cyclic cohomology. The similarity between these two types of modules is reflected in the fact that an alteration of the multiplication of the Drinfeld double leads to another algebra, the anti-Drinfeld double, which parametrises the anti-Yetter–Drinfeld modules. The role of pairs in involution in this setting was established by Hajac and Sommerhäuser. They proved that these pairs correspond to anti-Yetter–Drinfeld modules whose underlying vector space is the ground field. Furthermore, they showed that such ‘one-dimensional’ modules correspond to algebra isomorphisms between the Drinfeld and anti-Drinfeld double.

Our aim is to extend the theory of pairs in involution to general rigid monoidal categories; a far reaching generalisation of modules over Hopf algebras. These are categories which have a weakly associative and unital tensor product in the sense sketched above and a notion of duality that parallels that of finite-dimensional representations of groups.

The first step for us is to establish a dictionary that translates Hopf algebraic concepts into categorical terms. In accordance with our previous considerations, the (Drinfeld) centre of a rigid monoidal category replaces the Yetter–Drinfeld modules. *Mutatis mutandis*, anti-Yetter–Drinfeld modules have been generalised to anti-Drinfeld centres. Again, these are categories with a type of commutativity encoded by half-braidings. Accounting for the slight differences between the definitions of Yetter–Drinfeld and anti-Yetter–Drinfeld modules, the half-braidings of the anti-Drinfeld centre flip the order of the tensor product and replace one of its factors by its bidual. The categorical pendant of being one-dimensional is to be ‘invertible’ under the multiplication given by the tensor product. To complete our dictionary, we show that pairs in involution translate to quasi-pivotal structures. That is, tensor product preserving natural isomorphisms between objects and ‘conjugates’ of their biduals.

In order to generalise the Hajac–Sommerhäuser characterisation of pairs in involution to the setting of rigid monoidal categories we prove that there is a canonical (left) action of the Drinfeld centre on the anti-Drinfeld centre. Furthermore, this module admits a dual. Hereof, we can deduce that the equivariant equivalences of categories between the Drinfeld and anti-Drinfeld centre are parametrised by the ‘invertible’ objects in the anti-Drinfeld centre. Additionally, a direct computation shows that these objects equate to quasi-pivotal structures. This establishes the categorical version of the Hajac–Sommerhäuser description of pairs in involution.

The language of rigid monoidal categories offers an abstraction of many concepts of the representation theory of (finite) groups. We have already outlined that it allows for suitable notions of taking tensor products and forming duals. However, in general one important concept is missing: traces of endomorphisms. Their well-definedness is tied to the existence of a pivotal structure, i.e. a monoidal natural isomorphism between each object and its bidual. Due to results by Barrett and Westbury it can be deduced that the pivotal structures on the finite-dimensional

Yetter–Drinfeld modules over a Hopf algebra are in bijection with its pairs in involution. Parallel to work of Shimizu, we show that, the ‘invertible’ objects of the anti-Drinfeld centre lead to pivotal structures on the Drinfeld centre. In addition, we answer his question whether this assignment is always surjective in the negative by constructing a counterexample. It is based on the category of ribbon tangles.

In the last part of this dissertation, we unify our Hopf algebraic findings with the categorical ones by studying Hopf monads. To roughly explain what monads are, we consider the following example. Any representation of a group can be seen as a vector space together with an action. This leads to a canonical functor from the category of representations of a group to the category of vector spaces which ‘forgets’ the action on objects and the equivariance of morphisms. Conversely, any vector space can be lifted to a free representation (by considering its tensor product with the group algebra). These ‘free’ and ‘forgetful’ functors form what is called an adjunction. In a sense, monads are ‘shadows’ of such adjoint pairs of functors. They are algebraic objects which we can study by the means of representation theory. As with finite-dimensional Hopf algebras, a monad is Hopf if and only if its modules are a rigid monoidal category. This can be made more concrete in terms of certain structure morphisms on the monad which implement the tensor product and taking duals.

Our aim is to define and investigate the anti-Drinfeld double of a Hopf monad. The approach we take is based on the construction of the Drinfeld double of a Hopf monad due to Day and Street as well as Bruguières and Virelizier. Their starting point is a ‘free’ functor, adjoint to the canonical ‘forgetful’ functor from the Drinfeld centre to its underlying category. Its definition is based on a certain colimit construction. The universal property of these colimits leads to an illustrative description of the Hopf monad structure associated to this adjunction. We adopt these techniques to the anti-Drinfeld centre by introducing a special type of action of monads on functors. In this manner, we obtain the anti-Drinfeld double of a Hopf monad. Just like the Drinfeld double parametrises the Drinfeld centre, the modules of the anti-Drinfeld double are isomorphic to the anti-Drinfeld centre. The action of the Drinfeld centre on the anti-Drinfeld centre is accounted for by a coaction of the Drinfeld double on the anti-Drinfeld double.

The definition of pairs in involution for Hopf algebras can be applied almost verbatim to the setting of Hopf monads. Using our categorical findings as translations this leads to a monadic version of the Hajac–Sommerhäuser theorem. We conclude our investigation by illustrating how the anti-Drinfeld double of a Hopf monad can be used to detect the existence of pivotal structures.

ZUSAMMENFASSUNG

Paare in Involution entstammen der Theorie der Hopf-Algebren. Sie finden Anwendungen im Bereich der Kategorientheorie, der Knoteninvarianten und der zyklischen Kohomologie. In der hier vorliegenden Dissertation wird die Frage beantwortet, ob alle endlich dimensional Hopf-Algebren solche Paare besitzen, ihr kategorielles Äquivalent definiert und, basierend auf unseren vorausgegangenen Resultaten, die Theorie von Paaren in Involution für Hopf-Monaden entwickelt und untersucht.



Die zentrale Struktur, die der vorliegenden Dissertation zugrunde liegt, sind Hopf-Algebren. Sie können grob als Verallgemeinerungen von Gruppen beschrieben werden, wobei eine Komultiplikation die Rolle der Diagonalabbildung übernimmt und ein nicht notwendigerweise involutiver Operator, der als Antipode bezeichnet wird, die Inversenbildung ersetzt. Für jede Hopf-Algebra besteht ein Paar in Involution aus einem Element, das in einer kanonischen Untergruppe dieser Algebra lebt, zusammen mit einem Charakter, so dass sie das Quadrat der Antipode der Hopf-Algebra implementieren. In einem vagen Sinne führen diese Paare zu spurähnlichen Operationen auf bestimmten Morphismusräumen über Hopf-Algebren. Dabei gilt die Zyklizitätsbedingung im Allgemeinen nur bis auf skalare Vielfache. Paare in Involution, für die dieser Skalar Eins ist, werden modular genannt. Sie übernehmen die Rolle eindimensionaler Koeffizienten in der von Connes und Moscovici definierten Hopf-zyklischen Kohomologietheorie. Unter anderem diese Anwendung veranlasste Hajac zu der Frage, ob jede endlichdimensionale Hopf-Algebra ein (modulares) Paar in Involution besitzt.

Zu ihrer Beantwortung, betrachten wir eine Klasse von Hopf-Algebren, die verallgemeinerte Taft-Algebren genannt werden. Diese ergeben sich aus der Theorie der (kleinen) Quantengruppen und können als "Quantenebenen" betrachtet werden. Für eine verallgemeinerte Taft-Algebra entsprechen (modulare) Paare in Involution Lösungen eines Systems linearer diophantischer Gleichungen, deren Koeffizienten von den Strukturparametern der Algebra abgeleitet sind. Eines unserer Hauptergebnisse ist die Angabe notwendiger und hinreichender Kriterien für die Existenz von Lösungen dieser Gleichungssysteme. Daraus können wir zwei Schlussfolgerungen ziehen. Es gibt endlichdimensionale Hopf-Algebren, die Paare in Involution besitzen, welche jedoch die Modularitätsbedingung nicht erfüllen können. Außerdem existieren endlichdimensionale Hopf-Algebren ganz ohne solche Paare.

Eine konzeptionellere Perspektive auf Paare in Involution ist durch Darstellungstheorie gegeben. Zur Herstellung dieses Zusammenhangs ist folgende Beobachtung hilfreich: Moduln über einer Hopf-Algebra besitzen eine monoidale Struktur. Das heißt, es gibt eine Multiplikation, die durch das Tensorprodukt gegeben ist, und eine Eins, den trivialen Modul, so dass Assoziativität und Neutralität (schwach) gelten. Diese Analogie legt nahe, dass man das Zentrum dieses "Monoids" betrachten kann. Dabei ist es allerdings nicht notwendig, zu fordern, dass die Multiplikation strikt kommutativ ist. Stattdessen betrachtet man natürliche Isomorphismen, die

die Reihenfolge der Multiplikation umkehren. Im Fall von Hopf-Algebren ist die Zentrumskonstruktion eng mit der Yang–Baxter-Gleichung verbunden. In seiner wegweisenden Arbeit über Quantengruppen² erhielt Drinfeld kanonische Lösungen für diese Gleichung, indem er jeder endlichdimensionalen Hopf-Algebra ihr Drinfeld-Doppel zuordnete. Moduln über dem Drinfeld-Doppel einer Hopf-Algebra können mit den sogenannten Yetter–Drinfeld Moduln identifiziert werden. Auf Hajac, Khalkhali, Rangipour und Sommerhäuser geht eine kleine Abänderung dieser Definition zurück, die zu der Kategorie der Anti-Yetter–Drinfeld Moduln führt. Diese, oder genauer gesagt eine Unterkategorie davon, dient als Quelle für Koeffizienten der Hopf-zyklischen Kohomologie. Die Ähnlichkeit dieser beiden Arten von Moduln zeigt sich auch darin, dass der dem Drinfeld-Doppel zugrunde liegende Vektorraum mit einer zweiten Multiplikation ausgestattet werden kann, sodass die Moduln der resultierenden Algebra, dem Anti-Drinfeld-Doppel, gleich den Anti-Yetter–Drinfeld Moduln sind. Die Rolle von Paaren in Involution in diesem Setting wurde durch Hajac und Sommerhäuser herausgearbeitet, welche gezeigt haben, dass diese Paare zwei zusätzliche äquivalente Charakterisierungen aufweisen. Sie entsprechen den Anti-Yetter–Drinfeld Moduln, deren zugrunde liegender Vektorraum der Grundkörper ist. Dies ist gleichbedeutend mit Algebrasomorphismen zwischen dem Drinfeld und dem Anti-Drinfeld-Doppel.

Unser Ziel ist es, die Theorie der Paare in Involution und ihr Zusammenspiel mit Anti-Yetter–Drinfeld Moduln sowie dem Anti-Drinfeld-Doppel auf rigid monoidale Kategorien zu erweitern. Dies sind Kategorien, die ein schwach assoziatives und unitales Tensorprodukt besitzen und deren Objekte eine Art von Dualität aufweisen, die der von endlichdimensionalen Darstellungen von Gruppen entspricht.

Der erste Schritt besteht für uns darin, Hopf-algebraische Konzepte in kategorielle Begriffe zu übersetzen. Gemäß unseren bisherigen Überlegungen ersetzt das (Drinfeld)-Zentrum einer rigid monoidalen Kategorie die Yetter–Drinfeld-Moduln. Auf ähnliche Weise lassen sich Anti-Yetter–Drinfeld-Moduln zum Anti-Drinfeld-Zentrum verallgemeinern. Das kategorielle Pendant der Eindimensionalität ist die “Invertierbarkeit” unter der durch dem Tensorprodukt gegebenen Multiplikation. Wir zeigen, dass sich in dieser Sprache Paare in Involution in quasipivotalen Strukturen übersetzen lassen. Das heißt, natürliche, mit den Tensorprodukten kompatible, Isomorphismen zwischen Objekten und “Konjugierten” ihrer Bidualen.

Zwei Beobachtungen erlauben es uns, die Hajac–Sommerhäuser-Charakterisierung von Paaren in Involution für rigid monoidale Kategorien zu verallgemeinern. Erstens gibt es eine kanonische Wirkung des Drinfeld-Zentrums auf das Anti-Drinfeld-Zentrum. Zweitens hat dieser Modul ein Duales. Daraus können wir ableiten, dass die äquivarianten Äquivalenzen von Kategorien zwischen dem Drinfeld- und dem Anti-Drinfeld-Zentrum durch die “invertierbaren” Objekte im Anti-Drinfeld-Zentrum parametrisiert werden. Zusätzlich folgt aus einer direkten Rechnung, dass diese Objekte quasipivotalen Strukturen entsprechen. Dies führt zu der kategoriellen Version der Hajac–Sommerhäuser-Beschreibung von Paaren in Involution.

Die Sprache rigider monoidaler Kategorien bietet eine Abstraktion vieler Konzepte der Darstellungstheorie (endlicher) Gruppen. Wir haben bereits skizziert, dass sich in ihnen über Tensorprodukte und Duale sprechen lässt. Im Allgemeinen fehlt jedoch ein wichtiger Begriff: Spuren von Endomorphismen. Ihre Wohldefiniertheit ist an die Existenz einer pivotalen Struktur gebunden, das heißt eines monoidalen

²V. G. Drinfeld. Quantengruppen. Proz. Int. Kongr. Math., 1987.

natürlichen Isomorphismus zwischen jedem Objekt und seinem Bidual. Aus Arbeiten von Barrett und Westbury lässt sich ableiten, dass die pivotalen Strukturen auf den Yetter–Drinfeld-Moduln über einer Hopf-Algebra mit ihren Paaren in Involution in Bijektion stehen. Parallel zu Arbeiten von Shimizu zeigen wir, dass die “invertierbaren” Objekte des Anti-Drinfeld-Doppels zu pivotalen Strukturen auf dem Drinfeld-Doppel führen. Außerdem beantworten wir seine Frage, ob diese Zuordnung immer surjektiv sei, durch die Konstruktion eines Gegenbeispiels. Es basiert auf der Kategorie der “Bandschleifen”.

Im letzten Teil dieser Dissertation vereinigen wir unsere Hopf-algebraischen Resultate mit den kategoriellen, indem wir Hopf-Monaden untersuchen. Um den Begriff der Monaden zu motivieren, betrachten wir das folgende Beispiel. Jede Darstellung einer Gruppe kann als ein Vektorraum zusammen mit einer Wirkung verstanden werden. Dies führt zu einem kanonischen Funktor von der Kategorie der Darstellungen einer Gruppe zur Kategorie der Vektorräume, der die Wirkung auf Objekten und die Äquivarianz auf Morphismen “vergisst”. Umgekehrt kann jedem Vektorraum durch Tensorieren mit der zugehörigen Gruppenalgebra eine freie Darstellung zugeordnet werden. Die “freien” und “Vergiss-” Funktoren bilden eine Adjunktion. Monaden sind gewissermaßen “Schatten” solcher adjungierter Funktorenpaare. Sie sind algebraische Objekte, die wir mit Hilfe von Darstellungstheorie untersuchen können. Ähnlich wie bei Hopf-Algebren sind Hopf Monaden dadurch charakterisiert, dass ihre Moduln eine rigid monoidale Kategorie bilden. Dies lässt sich anhand bestimmter Strukturmorphisamen auf der Monade beschreiben, die das Tensorieren und Dualen bilden implementieren.

Unser Ziel ist es, das Anti-Drinfeld-Doppel einer Hopf-Monade zu definieren und zu untersuchen. Der dabei verfolgte Ansatz basiert auf der Konstruktion des Drinfeld-Doppel einer Hopf-Monade durch Day und Street sowie Bruguières und Virelizier. Den Ausgangspunkt bildet ein freier Funktor, der adjungiert zum kanonischen Vergissfunktore ist. Seine Definition basiert auf bestimmten Kolimites. Deren Universalität führt zu einer anschaulichen Beschreibung der mit dieser Adjunktion verbundenen Hopf-Monadenstruktur. Wir übernehmen diese Techniken für das Anti-Drinfeld-Zentrum, indem wir eine spezielle Art der Wirkung von Monaden auf Funktoren einführen. Auf diese Weise erhalten wir das Anti-Drinfeld-Doppel einer Hopf-Monade. So wie das Drinfeld-Doppel das Drinfeld-Zentrum parametrisiert, sind die Moduln des Anti-Drinfeld-Doppels isomorph zum Anti-Drinfeld-Zentrum. Der Wirkung des Drinfeld-Zentrums auf dem Anti-Drinfeld-Zentrum wird durch eine Kowirkung des Drinfeld-Doppels auf dem Anti-Drinfeld-Doppel Rechnung getragen.

Die Definition von Paaren in Involution für Hopf-Algebren lässt sich fast wörtlich auf Hopf-Monaden übertragen. Unter Verwendung unserer kategoriellen Resultate als Übersetzungen führt dies zu einer monadischen Version des Hajac–Sommerhäuser-Theorems. Als Anwendung dieser Theorie beweisen wir, dass, wenn die nötigen Monaden existieren, das Anti-Drinfeld-Doppel verwendet werden kann, um die Existenz pivotaler Strukturen nachzuweisen.

CONTENTS

1. Introduction	1
Hopf algebras and Tannaka–Krein reconstruction	1
Yetter–Drinfeld modules	2
Pairs in involution	2
Square roots of the distinguished group-likes and Radford’s S^4 -formula	3
Generalised Taft algebras	3
Quasitriangular and unimodular Hopf algebras without pairs in involution	4
Pairs in involution and pivotal structures on the Yetter–Drinfeld modules	4
Anti-Yetter–Drinfeld modules and the Hajac–Sommerhäuser theorem	5
Bimodule categories and the centre construction	6
A categorical perspective on pairs in involution	6
Heaps and induced pivotal structures	7
Reconstruction revisited: Hopf and comodule monads	8
The anti-Drinfeld double of a Hopf monad	9
Pairs in involution for the anti-Drinfeld double of a Hopf monad	9
Structure and outline of the thesis	10

Paper I.**A Hopf algebra without a modular pair in involution** 13

1. Introduction	14
2. Proof	14

Paper II.**Generalised Taft algebras and pairs in involution** 17

1. Introduction	18
Main result	18
Pivotal categories and anti-Yetter–Drinfeld modules	18
Outline	18
2. Pairs in involution	19
3. Generalised Taft algebras	20
3.1. Yetter–Drinfeld and anti-Yetter–Drinfeld modules	20
3.2. Nichols algebras and bosonisations	22
3.3. Generalised Taft algebras	23
4. Hopf algebras without pairs in involution	24
4.1. Properties of generalised Taft algebras	25
4.2. Pairs in involution as solutions of Diophantine equations	26
5. Anti-Drinfeld doubles and pivotality	29

Paper III.

Pivotality, twisted centres and the anti-double of a Hopf monad	33
1. Introduction	34
The Hopf algebraic case	34
Twisted centres and pivotality	34
Reconstruction: Comodule monads	35
Outline	36
Part 1. Twisted centres and pivotality	37
2. Monoidal categories, bimodule categories and the centre construction	38
2.1. From monoidal to pivotal categories	39
2.2. Braided categories	44
2.3. Bimodule categories and the centre construction	44
3. Heaps	47
4. Pivotal structures and twisted centres	48
4.1. Twisted centres and their Picard heaps	49
4.2. Quasi-pivotality	53
4.3. Pivotality of the Drinfeld centre	55
Part 2. The anti-double of a Hopf monad and pairs in involution	71
5. Bimodule and comodule monads	72
5.1. Monads and their representation theory	72
5.2. Bimonads and monoidal categories	75
5.3. The graphical calculus for bimonads	76
5.4. Comodule monads	78
5.5. Cross products and distributive laws	84
5.6. Coend calculus	87
6. A monadic perspective on twisted centres	87
6.1. Centralisable functors and the central bimonad	88
6.2. Centralisers and comodule monads	92
6.3. The Drinfeld and anti-Drinfeld double of a Hopf monad	96
6.4. Pairs in involution for Hopf monads	98
References	103

1. INTRODUCTION

Pairs in involution are a multi-faceted topic in the theory of Hopf algebras. This is reflected in the breadth of content of the following three papers, published in a six year period between 1993 and 1999, each of which could be considered as a possible starting point for the study of such pairs in their own right. Kauffman and Radford used pairs in involution in [KR93] to determine necessary and sufficient conditions for the Drinfeld double of a finite-dimensional Hopf algebra to be ribbon. A different application was given by Connes and Moscovici who utilised them as coefficients for their formulation of Hopf-cyclic cohomology, see [CM99]. The connection between such pairs and the spherical Hopf algebras investigated by Barrett and Westbury [BW99] is less direct; it requires passing to the Drinfeld double, whose spherical elements equate to pairs in involution as we will prove later. Our approach to pairs in involution will incorporate, as suggested by this brief outline, different points of view and utilise tools from various mathematical disciplines.

The subsequent introduction to the theory and applications of pairs in involution is intended for Hopf algebraists and category theorists.

Hopf algebras and Tannaka–Krein reconstruction. Hopf algebras are a mathematical structure whose representations resemble those of (finite) groups. A more precise account of this figure of thought is given in terms of reconstruction theory. Tannaka([Tan38]) and Krein([Kre49]) proved independently that finite groups can be recovered from their category of representations. Building on these results, the idea of considering algebraic structures as ‘coordinate systems’ of their representations has been expanded into a topic of its own—*Tannaka–Krein reconstruction*. A detailed treatment of the Hopf algebraic aspects of this subject are given for example in [Ul90] and [Sch92]. While we do not present this theory in its entirety, we want to succinctly outline parts of it in order to sketch the above indicated connection between groups and Hopf algebras. In addition, this will provide us with a natural approach to our generalisation of pairs in involution to the setting of rigid monoidal categories and monads. To keep our exposition consistent with our ensuing considerations, we restrict ourselves to the case of finite-dimensional algebras over an algebraically closed field \mathbb{k} of characteristic zero.

The starting point of the variant of Tannaka–Krein reconstruction we are about to illustrate here is a category $H\text{-Mod}^{\text{fin}}$ of finite-dimensional modules over a finite-dimensional Hopf algebra H . It admits a canonical forgetful functor to vector spaces from which the underlying vector space and algebra structure of H can be retrieved up to an isomorphism. Additionally, $H\text{-Mod}^{\text{fin}}$ is a *monoidal category*. That is, there exists a weakly associative and unital ‘multiplication’ on it, which in the present case is given by an extension of the tensor product of vector spaces to $H\text{-Mod}^{\text{fin}}$. This determines the *comultiplication* and *counit* of H —an abstraction of the diagonal map and trivial module over a group. Monoidal categories whose objects have duals in a fashion similar to finite-dimensional representations over groups are called *rigid*. The rigidity of $H\text{-Mod}^{\text{fin}}$ establishes an anti-algebra, anti-coalgebra morphism $S: H \rightarrow H$, the *antipode* of H . It is the Hopf algebraic variant of taking inverses in a group. Since H was supposed to be finite-dimensional, its antipode is invertible but not necessarily involutory. In contrast with the group case, this leads to two, possibly distinct, actions on the dual vector space of any finite-dimensional left module over H . On the categorical side this equates to a concept of left and right

duality in $H\text{-Mod}^{\text{fin}}$. In a sense, the present dissertation is about the disparity between left and right duals. However, not in the category modules over H but a close relative thereof which is related to solutions of the Yang–Baxter equation.

Yetter–Drinfeld modules. The finite-dimensional *Yetter–Drinfeld modules* over a Hopf algebra H are simultaneously finite-dimensional modules and comodules over H with a compatibility between action and coaction, [Mon93, Chapter 10]. They again form a rigid monoidal category ${}^H_H\mathcal{YD}^{\text{fin}}$ whose tensor product can be thought of as ‘commutative’. This is implemented by a *braiding*, i.e. a natural isomorphism which flips the order in which terms are tensored together. For a finite-dimensional Hopf algebra H the Yetter–Drinfeld modules can be realised as the modules over the *Drinfeld double* $D(H)$ over H . This construction, proposed by Drinfeld in 1987 in [Dri87], equips the tensor product $H^\circ \otimes H$ of H with its dual with a new multiplication derived from the multiplications of H° and H as well as the compatibility condition of the Yetter–Drinfeld modules. The braiding of the Yetter–Drinfeld modules over H can be translated to a *quasitriangular* structure on the Drinfeld double which in turn leads to solutions of the Yang–Baxter equation.

Later, we will exemplify how pairs in involution are reconstructions of certain natural isomorphisms between Yetter–Drinfeld modules and their (left) biduals.

Pairs in involution. Before we elaborate this somewhat abstract perspective on pairs in involution, we want to discuss a more direct approach going back to work of Connes and Moscovici, see [CM99, CM00].

In order to understand what these pairs are and why they are needed in various algebraic contexts, let us for now suppose that H is a Hopf algebra with involutory antipode S , in formulas $S^2 = \text{id}_H$. We want to consider a trace-like operation arising in Hopf-cyclic cohomology. Suppose $n \in \mathbb{N}$ to be a natural number and let X be a finite-dimensional left module over H . We write $C^n(X) := \text{Hom}_H(X^{\otimes n+1}, \mathbb{k})$ for the space of H -linear maps between the $n+1$ -fold tensor product of X with itself and the trivial module over H , which we denote by \mathbb{k} . There exists a well-defined isomorphism of vector spaces

$$\tau: C^n(X) \rightarrow C^n(X), \quad \tau(f)(x^0 \otimes x^1 \otimes \cdots \otimes x^n) = f(x^1 \otimes \cdots \otimes x^n \otimes x^0).$$

The compatibility between the cyclic permutation of the inputs of $f \in C^n(X)$ induced by τ and the action of H is proved using that $S = S^{-1}$ or, equivalently, that the left and right dual of X coincide.

Motivated by finding an analogue to Lie algebra cohomology in the setting of noncommutative geometry, Connes and Moscovici observed that even if the antipode of H is not involutory a trace-like map $\tau: C^n(X) \rightarrow C^n(X)$ exists, provided H admits modular pairs in involution, see [CM99, CM00]. To state their definition we use reduced Sweedler notation and write $h_{(1)} \otimes h_{(2)} := \Delta(h) \in H \otimes H$ for the comultiplication of an element $h \in H$.

Definition. A *pair in involution* for a Hopf algebra H over a field \mathbb{k} consists of a group-like $l \in H$ and a character $\beta: H \rightarrow \mathbb{k}$ which satisfy the antipode condition

$$S^2(h) = \beta(h_{(3)})\beta^{-1}(h_{(1)})lh_{(2)}l^{-1}, \quad \text{for all } h \in H.$$

If additionally $\beta(l) = 1$, we call (l, β) *modular*.

Given a modular pair in involution (l, β) , we write $C_{(l, \beta)}^n(X) := \text{Hom}_H(X^{\otimes n+1}, \mathbb{k}_\beta)$ for the vector space of H -module morphisms between the $(n+1)$ -fold tensor product

of X with itself and the representation \mathbb{k}_β arising from the character β . Furthermore, we equip $C_{(l,\beta)}^n(X)$ with a ‘twisted’ cyclic permutation

$$\tau_l: C_{(l,\beta)}^n(X) \rightarrow C_{(l,\beta)}^n(X), \quad \tau_l(f)(x^0 \otimes x^1 \otimes \cdots \otimes x^n) = f(x^1 \otimes \cdots \otimes x^n \otimes l \triangleright x^0).$$

The antipode condition of (l, β) implies that we can still ‘relate’ left and right duals with each other, therefore ensuring the compatibility between the action of H and the twisted cyclic permutation of inputs $\tau_l: C_{(l,\beta)}^n(X) \rightarrow C_{(l,\beta)}^n(X)$. Moreover, the modularity $\beta(l) = 1$ of the pair (l, β) entails $\tau_l^{n+1} = \text{id}_{C_{(l,\beta)}^n(X)}$.

If X is a module algebra, the collection $(C_{(l,\beta)}^n(X))_{n \geq 0}$ can be promoted to a module over Connes’ cyclic category Λ , see [CM99]. A conceptual proof is given in Theorem 2.2 of [HKRS04a]. The study of such modules arising from Hopf algebras is the content of Hopf-cyclic cohomology, which, since its initial conception, has been extended to various contexts beyond Hopf algebras, for example to Hopf algebroids, see [KK11]. A peculiarity of Hopf-cyclic cohomology is that in the absence of an involutory antipode there are no canonical coefficients; instead it always depends on the choice of a modular pair in involution, which motivates the following question.

QUESTION 1: Does every finite-dimensional Hopf algebra admit a pair in involution and, if so, also a modular one?

Square roots of the distinguished group-likes and Radford’s S^4 -formula.

Kauffman and Radford gave in [KR93] sufficient conditions for the existence of pairs in involution in order to determine which Hopf algebras lead to ribbon invariants. Their argument revolves around Radford’s celebrated S^4 -formula, developed in [Rad76]. A consequence of the fundamental theorem of Hopf modules, see [LS69, Proposition 1], is that any finite-dimensional Hopf algebra H admits a one-dimensional subspace $L(H) \subseteq H$, called the *left integrals* of H , whose elements satisfy $h\Lambda = \varepsilon(h)\Lambda$ for all $h \in H$ and $\Lambda \in L(H)$. Furthermore, there is a unique character $\alpha: H \rightarrow \mathbb{k}$, the *distinguished character* of H , such that $\Lambda h = \alpha(h)\Lambda$. In case $\alpha = \varepsilon$ is the counit of H , we refer to H as a *unimodular* Hopf algebra. Applying the same considerations to the dual H° of H and using that $H^{\circ\circ} \cong H$, we obtain the *distinguished group-like* of H . Radford’s S^4 -formula states that the fourth power of the antipode is given by the conjugate actions of the distinguished group-likes and characters, i.e.

$$S^4(h) = \alpha(h_{(3)})\alpha^{-1}(h_{(1)})g^{-1}h_{(2)}g, \quad \text{for all } h \in H.$$

The pairs in involution leading to ribbon invariants are square roots of the distinguished group-like and character of H , see [KR93, Theorem 3]. The idea of Kauffman and Radford how to determine their existence relies on two observations. First, by the Nichols–Zoeller theorem, [NZ89, Theorem 7], the orders of the group of group-likes as well as the group of characters divide the dimension of the Hopf algebra. Second, every element of a group of odd order has a unique square root. This entails that any Hopf algebra H of odd dimension whose square of the antipode has odd order admits a unique pair in involution (l, β) such that l^{-2} and β^2 are the distinguished group-like and character, respectively, see [KR93, Corollary 3].

Generalised Taft algebras. We give a complete answer of Question 1 in our articles [HK19] and [Hal21]. It is of similar nature to [KR93], in that the existence of (modular) pairs in involution is linked to solutions of certain equations. The strategy for this is to consider a well-studied class of Hopf algebras—the generalised

Taft algebras. Following for example the articles [ARS10] and [HY10] they might be viewed as Borel parts of certain small quantum groups, introduced by Lusztig in [Lus90]. Closely related to this, they can be identified with the rank two case of the quantum linear spaces investigated in [AS98a] and could therefore also be referred to as quantum planes, see also [Man87].

A conceptual approach to generalised Taft algebras revolving around the notion of Nichols algebras³ is discussed in Section II.3. At this point, however, it suffices for us to characterise them as being finite-dimensional Hopf algebras generated by a group-like element, spanning a finite cyclic group, and two twisted-primitive, nilpotent elements such that all three generators commute up to some roots of unity. The details of this presentation are given in Theorem II.3.14.

The systematic study of generalised Taft algebras is carried out in Section II.4. In Theorem II.4.1 we prove this class of Hopf algebras to be closed under duality, which implies that both the group-likes and characters of a generalised Taft algebra form isomorphic finite cyclic groups. This leads to one of our main results, Theorem II.4.5: the (modular) pairs in involution for a generalised Taft algebra equate to solutions of a system of Diophantine equations whose coefficients are derived from the Hopf algebra structure. Subsequently, we classify their solutions in Theorem II.4.8. With the constraints found therein we can answer Question 1 in Theorem I.1.2 and Lemma II.4.10. These findings can be summarised as follows.

Theorem 1. *There are two families \mathcal{H}_1 and \mathcal{H}_2 of generalised Taft algebras, both with countably infinite cardinality, such that*

- (i) *the members of \mathcal{H}_1 do not admit pairs in involution, and*
- (ii) *all elements of \mathcal{H}_2 have such pairs but they cannot satisfy the modularity condition.*

Quasitriangular and unimodular Hopf algebras without pairs in involution.

Due to Theorem 1 of [KR93], every ribbon Hopf algebra has a pair in involution. In the further course of Section II.4 we investigate whether there are other properties of Hopf algebras, which entail the existence of such pairs. While Lemma II.4.13 and Corollary II.4.14 show that the restrictions imposed on a generalised Taft algebra by requiring it to be unimodular or quasitriangular result in the existence of these pairs, this is not true in general. As discussed in Theorem II.4.12, the Drinfeld double $D(H)$, which is always unimodular and quasitriangular, admits a pair in involution if and only if its underlying Hopf algebra H does⁴.

Towards a Morita-theoretic view on such pairs, we observe in Lemma II.5.1 that Hopf algebras which are isomorphic only as algebras need not share the property of having a pair in involution. This suggests a link between these pairs and the monoidal structure of the category of finite-dimensional modules of a Hopf algebra.

Pairs in involution and pivotal structures on the Yetter–Drinfeld modules.

In [BW99] Barrett and Westbury investigated traces in rigid monoidal categories.

³Nichols algebras are a braided version of symmetric algebras, see [AS02, Section 2]. In particular, they are vector spaces endowed with a multiplication, comultiplication and antipode. These maps satisfy the usual axioms of Hopf algebras, except that the compatibility between the multiplication and comultiplication take a braiding into account. Generalised Taft algebras arise via Radford’s biproduct construction ([Rad85]), which is also called Majid’s bosonisation ([Maj94]), as a combination of a certain type of Nichols algebras with group algebras of finite cyclic groups.

⁴In fact, the proof of Theorem 4.12 shows that a pair in involution for H can be lifted to a modular one for the Drinfeld double $D(H)$.

Their definition depends on a pivotal structure. That is, a monoidal natural isomorphism between every object and its bidual. Rigid monoidal categories with such a natural isomorphism are called *pivotal*.

In Section II.5 we explore the connection between pivotality and pairs in involution. It can be deduced from [BW99, Proposition 3.6] that the pivotal structures on the category $H\text{-Mod}^{\text{fin}}$ of finite-dimensional modules over a finite-dimensional Hopf algebra H can be identified with group-like elements $g \in H$ implementing the square of the antipode by their adjoint action. Combined with a result of Radford, [Rad93, Proposition 9], which identifies the group-likes of the Drinfeld double $D(H)$ with pairs comprising a character and a group-like of H , we obtain that pairs in involution correspond to pivotal structures on the finite-dimensional Yetter–Drinfeld modules over H , see Lemma II.5.5. From this point of view our examples of Hopf algebras without (modular) pairs in involution bear two concrete implications. The Yetter–Drinfeld modules over a Hopf algebra H without pairs in involution are not pivotal. If these pairs exist for H but none of them is modular, the category of Yetter–Drinfeld modules is pivotal but neither the finite-dimensional modules nor comodules over H are. These observations motivate our second question.

QUESTION 2: What is the categorical analogue of pairs in involution and can they be used to classify pivotal structures on generalisations of Yetter–Drinfeld modules?

Our first step towards answering it is to recognise these pairs as place of a broader structure.

Anti-Yetter–Drinfeld modules and the Hajac–Sommerhäuser theorem.

With the introduction of (stable) anti-Yetter–Drinfeld modules, Hajac et al. made a significant contribution to the systematic investigation of coefficients for Hopf-cyclic cohomology, see [HKRS04a, HKRS04b]. These provide a conceptual framework for our understanding of pairs in involution. Like Yetter–Drinfeld modules, they are modules with a compatible comodule structure. Contrary to their well-known ‘cousins’, they do not form a monoidal category. Instead, the tensor product of a Yetter–Drinfeld module with an anti-Yetter–Drinfeld module is again an anti-Yetter–Drinfeld module, see [HKRS04b, Lemma 2.3]. A more succinct way of saying this is to state that for any Hopf algebra H the tensor product of its modules and comodules extends to a weakly associative and unital action functor of the Yetter–Drinfeld on the anti-Yetter–Drinfeld modules. Hence, the anti-Yetter–Drinfeld modules form a *module category* over the Yetter–Drinfeld modules. Reconstruction allows us to identify the anti-Yetter–Drinfeld modules of H with modules over its so-called anti-Drinfeld double $A(H)$, see [HKRS04b, Section 4]. Its construction parallels that of the Drinfeld double. The underlying vector space of $A(H)$ is $H^\circ \otimes H$ and the algebra structure is, as before, derived from the multiplications of H° and H as well as the compatibility condition of anti-Yetter–Drinfeld modules. The action of the Yetter–Drinfeld on the anti-Yetter–Drinfeld modules materialises as a coaction of $D(H)$ on $A(H)$ which is compatible with the algebra structure of $A(H)$. In other words, the anti-Drinfeld double is a *comodule algebra* over the Drinfeld double.

Pairs in involution can be interpreted as examples of anti-Yetter–Drinfeld modules in the following way: given such a pair (l, β) for a Hopf algebra H , we endow the ground field \mathbb{k} with a coaction induced by $l \in H$ and an action implemented by the convolution inverse $\beta^{-1}: H \rightarrow \mathbb{k}$ of the character β . A direct computation shows that for the above defined module and comodule structure the antipode condition

of the pair (l, β) and the compatibility condition between the action and coaction of anti-Yetter–Drinfeld modules coincide. The significance of pairs in involution among the anti-Yetter–Drinfeld modules is captured by the following theorem due to Hajac and Sommerhäuser:

Theorem (Theorem II.3.4). *For any finite-dimensional Hopf algebra H over \mathbb{k} the following statements are equivalent:*

- (i) *The Hopf algebra H admits a pair in involution.*
- (ii) *There exists an anti-Yetter–Drinfeld module over H with \mathbb{k} -dimension one.*
- (iii) *The Drinfeld and anti-Drinfeld double of H are isomorphic as algebras.*

Bimodule categories and the centre construction. Our solution to the problem posed in Question 2 is given in the first part of [HZ22]. An essential component is the development of a categorical version of the previous theorem. Coming from the perspective of Tannaka–Krein reconstruction, we substitute the role of a Hopf algebra in the description of pairs in involution with a rigid monoidal category \mathcal{C} . That is, a category with a (weakly) associative and unital product in which every object has a left and right dual. This leaves us with the task of transferring the notions of Yetter–Drinfeld and anti-Yetter–Drinfeld modules as well as pairs in involution into this abstract setting.

For this, we consider (bi-)module categories over monoidal categories. As the name suggests, these are categories endowed with compatible left and right actions by monoidal categories. One of the first accounts⁵ of module categories is given in the work of Crane and Frenkel on four-dimensional topological quantum field theories([CF94]). Later, Ostrik carried out an extensive investigation of these categories in [Ost03]. Module categories are a natural structure to consider in the study of ‘higher-dimensional algebra’ as sketched in [BD95] and provide a wide range of applications, see for example [FS03] and [Gre10].

The passage from bimodule categories to generalisations of Yetter–Drinfeld and anti-Yetter–Drinfeld modules is given by the Drinfeld centre construction. As stated in [Kas95, Chapter XIII], it dates back to works of Drinfeld(unfinished), Joyal and Street([JS91]) as well as Majid([Maj91]). The centre of a bimodule category \mathcal{M} over a monoidal category \mathcal{C} is a category which we denote by $Z(\mathcal{M})$. Its objects are pairs comprising an object of \mathcal{M} together with a natural isomorphism, called a *half-braiding*, that implements a coherent way of interchanging the right action on this object with the left one. The morphisms of the centre $Z(\mathcal{M})$ are all arrows of \mathcal{M} which ‘commute’ with the respective half-braidings. The centre of a monoidal category \mathcal{C} considered as a bimodule over itself is called the *Drinfeld centre*. It is a braided monoidal category that generalises the Yetter–Drinfeld modules: if \mathcal{C} are the modules of a finite-dimensional Hopf algebra H , there is a braided equivalence between the centre of \mathcal{C} and the Yetter–Drinfeld modules of H . A proof can be found for example in [Kas95, Theorem XIII.5.1]. The Drinfeld centre has manifold applications. For example it can be used to construct link or tangle invariants which generalise the Jones polynomial, see [Tur88] and [RT90].

A categorical perspective on pairs in involution. The similarity between Yetter–Drinfeld and anti-Yetter–Drinfeld modules suggests that a modification of the Drinfeld centre leads to a suitable replacement of the anti-Yetter–Drinfeld modules.

⁵A brief discussion of the history of module categories is given in Section 7 of [EGNO15].

To this end, we consider variants of the regular bimodule whose actions are altered by precomposing with a monoidal endofunctor. A particularly important example for us is given by twisting the right action of a rigid monoidal category \mathcal{C} on itself with its (left) biduality functor. We write $A(\mathcal{C})$ for the centre of the resulting bimodule category and call it the *anti-Drinfeld* centre of \mathcal{C} . In [FSS17] its trace-like properties were examined and applications in topological quantum field theories were shown. Similar considerations can also be found in [DSS21, Section 3.2.2]. The reason for calling $A(\mathcal{C})$ the anti-Drinfeld centre of \mathcal{C} is due to [HKS19] where it is proven that if \mathcal{C} is the category of finite-dimensional modules over a Hopf algebra H , then its anti-Drinfeld centre corresponds to the anti-Yetter–Drinfeld modules over H .

In Section III.4 we study the anti-Drinfeld centre and the possibility of it leading to a categorical description of pairs in involution. An essential role is played by a variation of the anti-Drinfeld centre $A(\mathcal{C})$ which we denote by $Q(\mathcal{C})$. It is obtained by twisting the left action of the regular bimodule with the bidualising functor instead of the right one and applying the centre construction to it. As in the Hopf algebraic case, the Drinfeld centre $Z(\mathcal{C})$ acts by tensoring on $A(\mathcal{C})$ from the left and on $Q(\mathcal{C})$ from the right, see Theorem III.4.2. Furthermore, we prove in Theorem III.4.4 that the dualising functor of \mathcal{C} extends to an equivalence between $A(\mathcal{C})$ and the opposite of $Q(\mathcal{C})$. Accordingly, we think of $Q(\mathcal{C})$ as the dual of $A(\mathcal{C})$. The interplay between the anti-Drinfeld centre and its dual allows us to show in Theorem III.4.6 that the $Z(\mathcal{C})$ -module equivalence between $Z(\mathcal{C})$ and $A(\mathcal{C})$ are parametrised by those objects in $A(\mathcal{C})$, whose underlying objects are invertible in \mathcal{C} . We call such objects \mathcal{C} -invertible. They generalise the notion of anti-Yetter–Drinfeld modules whose underlying vector space is one-dimensional.

Our adaptation of pairs in involution to general rigid monoidal categories are what we will call quasi-pivotal structures. These consist of an invertible object, replacing the character, and, instead of a group-like, a monoidal natural isomorphism between every object and a conjugate of its bidual. For a precise statement, we refer the reader to Definition III.4.10. A simple computation, carried out in Lemma III.4.12, identifies the \mathcal{C} -invertible objects of the anti-Drinfeld centre $A(\mathcal{C})$ with the quasi-pivotal structures of \mathcal{C} . This leads to one of the main results of Section III.4: the categorical version of the Hajac–Sommerhäuser characterisation of pairs in involution.

Theorem 2 (Theorem III.4.14). *Let \mathcal{C} be a rigid monoidal category. The following are equivalent:*

- (i) *The category \mathcal{C} is quasi-pivotal.*
- (ii) *There exists a \mathcal{C} -invertible object in $A(\mathcal{C})$.*
- (iii) *There is an equivalence of $Z(\mathcal{C})$ -module categories between $Z(\mathcal{C})$ and $A(\mathcal{C})$.*

Heaps and induced pivotal structures. With a categorical interpretation of pairs in involution established, we turn in the second half of Section III.4 to the second part of Question 2 and investigate how the \mathcal{C} -invertible objects of $A(\mathcal{C})$ induce pivotal structures on $Z(\mathcal{C})$. This provides an alternative view on results given by Shimizu in [Shi16].

The basis for our considerations is the observation that both the isomorphism classes of \mathcal{C} -invertible objects of the anti-Drinfeld centre and the pivotal structures of $Z(\mathcal{C})$ can be organised into heaps. That is, they admit a ternary multiplication operation that extends the concept of affine spaces to general groups, see Section III.3. Alternatively, a perspective on heaps as torsors is given in the article [BS11b].

In Lemma III.4.15 we prove that the half-braiding of a \mathcal{C} -invertible object can be used to construct a pivotal structure on $Z(\mathcal{C})$. As described in the first half of Theorem III.4.23, this assignment can be interpreted as a morphism of heaps between the Picard heap of the anti-Drinfeld centre of \mathcal{C} and the heap of pivotal structures on $Z(\mathcal{C})$. This raises the question whether this morphism is injective or surjective. While in many cases, such as \mathcal{C} being a finite tensor category over an algebraically closed field, two different elements of the Picard heap $\text{Pic } A(\mathcal{C})$ induce different pivotal structures, see Remark III.4.24, this is not true in general. Instead, we have to take the *symmetric* or *transparent* invertible objects of $Z(\mathcal{C})$ into account, i.e. invertible objects in the Drinfeld centre whose half-braidings square to the identity. These act by tensoring on $\text{Pic } A(\mathcal{C})$ and we can consider the quotient heap $\text{Pic } A(\mathcal{C})/\sim$. Now, Lemma III.4.21 proves that two elements of $A(\mathcal{C})$ induce the same pivotal structure if and only if they are in the same orbit under this action. This results, see Theorem III.4.23, in an injective heap morphism

$$\iota: \text{Pic } A(\mathcal{C})/\sim \rightarrow \text{Piv } Z(\mathcal{C}).$$

Again, due to [Shi16], all pivotal structures on a finite tensor category over an algebraically closed field originate from \mathcal{C} -invertible objects in the anti-Drinfeld centre. In the introduction of same article, Shimizu conjectures that this is not true in general. We prove this by considering a category \mathcal{B} that might loosely be described as unoriented tangles in \mathbb{R}^4 with zero or one ‘bead’ threaded onto them. The explicit description of the automorphism groups of objects in \mathcal{B} given in Theorem III.4.31 leads us to Theorem III.4.38:

Theorem 3. *There exists a pivotal structure on $Z(\mathcal{B})$ which is not induced by an \mathcal{B} -invertible object in $A(\mathcal{B})$.*

The third and last main question of this thesis has the purpose of mediating between the Hopf algebraic and categorical view on pairs in involution. A possible answer is due to second part of our article [HZ22].

QUESTION 3: Is there a notion of an anti-Drinfeld double of a Hopf monad and can it be used to detect pivotal structures?

Reconstruction revisited: Hopf and comodule monads. As described at the beginning of the introduction, the examination of ‘structure preserving’ functors from a rigid monoidal category \mathcal{C} to the category of vector spaces is a crucial part in Tannaka–Krein reconstruction. A natural generalisation of this procedure is given by replacing Vect with any suitable monoidal ‘base’ category \mathcal{V} , for example bimodules over an algebra, and circumvent the need of finding an algebraic datum inside \mathcal{V} by studying adjunctions between \mathcal{C} and \mathcal{V} directly. In this manner we can subsume various related constructions, such as Hopf algebras and Hopf algebroids ([Szl03]) in one terminology: Hopf monads. Their definition and representation theory are discussed in Section III.5. Instead of algebras over a ground field \mathbb{k} they are based on monads. That is, endofunctors with an associative and unital multiplication modelled by natural transformations. Defining monads with compatible comultiplications poses the problem that, due to the lack of canonical braidings, the axioms of bialgebras do not generalise to endofunctors categories. A possible solution is given in terms of mixed distributive laws, see [MW11]. The approach, which we will follow, is due to Boardman and Moerdijk, see [Boa95, Moe02]. It is based on the observation that for every monad $B: \mathcal{V} \rightarrow \mathcal{V}$ there is a bijective correspondence

between extensions of the monoidal structure of \mathcal{V} to the modules \mathcal{V}^B of B and ways of endowing B with a certain type of natural transformation. This leads to the notion of *bimonads*. These can be thought of as parametrisations of monoidal categories. As defined by Bruguières and Virelizier in [BV07], *Hopf monads* are bimonads with left and right antipodes. The latter are natural transformations modelling the rigid structures on the modules of the bimonads.

In addition to a replacement of Hopf algebras, we need a monadic version of comodule algebras. This is given by the *comodule monads* of Aguiar and Chase, see [AC12]. Let \mathcal{M} be a module category over \mathcal{V} . In the Tannaka–Krein dictionary between algebraic and categorical structures, a comodule monad $K: \mathcal{M} \rightarrow \mathcal{M}$ over a bimonad $B: \mathcal{V} \rightarrow \mathcal{V}$ corresponds to a (unique) lift of the action of \mathcal{V} on the module category \mathcal{M} to an action of \mathcal{V}^B on \mathcal{M}^K .

The anti-Drinfeld double of a Hopf monad. Our construction of the anti-Drinfeld double $Q(H)$ of a Hopf monad $H: \mathcal{V} \rightarrow \mathcal{V}$ is carried out in Section III.6. It mimics the procedure outlined in [BV12]. Since we do not assume that \mathcal{V} is symmetric or braided, it will implement $\mathbf{Q}(\mathcal{V}^H)$ instead of $\mathbf{A}(\mathcal{V}^H)$.

Building on results of Day and Street, [DS07], Bruguières and Virelizier described in [BV12] the Drinfeld double $D(H)$ of a Hopf monad $H: \mathcal{V} \rightarrow \mathcal{V}$ under the assumption that certain colimits, called *coends*, exist. From these, a left adjoint to the forgetful functor $U^{(Z)}: \mathbf{Z}(\mathcal{V}^H) \rightarrow \mathcal{V}^H$ is constructed. It admits a ‘universal coaction’ which, due to the extended factorisation property, see [BV12, Lemma 5.4], allows us to reconstruct the central Hopf monad $\mathfrak{D}(H): \mathcal{V}^H \rightarrow \mathcal{V}^H$. Its modules are equivalent as a rigid monoidal category to $\mathbf{Z}(\mathcal{V}^H)$. The Drinfeld double of H is the cross product $\mathfrak{D}(H) \rtimes H$ which, by a suitable adaptation of Beck’s theory of distributive laws, can be described as a product of two monads on \mathcal{V} with a twisted multiplication. Analogous to the classical case, it parametrises the Drinfeld centre $\mathbf{Z}(\mathcal{V}^H)$. In Definition III.6.9 we introduce actions of bimonads on functors which are in a certain sense compatible with the monoidal structures of their source and target categories. This allows us to extend the above sketched construction to module categories and obtain the anti-Drinfeld double $Q(H): \mathcal{V} \rightarrow \mathcal{V}$ of H in Definition III.6.17. It can either be characterised as a cross product $\mathfrak{Q}(H) \rtimes H$ of the anti-central monad with H or, equivalently, as the composite of two monads on \mathcal{V} with an multiplication altered by a distributive law. The fact that the Drinfeld centre acts on the anti-Drinfeld centre is reflected by the anti-Drinfeld double $Q(H)$ being a comodule monad over $D(H)$. Accordingly, we prove in Theorem III.6.16, that $Q(H)$ implements the dual of the anti-Drinfeld centre $\mathbf{Q}(\mathcal{V}^H)$ of \mathcal{V}^H as a right module category over the Drinfeld centre $\mathcal{V}^{D(H)}$, viewed as the modules over $D(H)$.

Pairs in involution for the anti-Drinfeld double of a Hopf monad. Having established the anti-double of a Hopf monad, we continue in Section III.6 by providing a monadic version of the Hajac–Sommerhäuser theorem.

In analogy with the Hopf algebraic case, we define the characters of a Hopf monad $H: \mathcal{V} \rightarrow \mathcal{V}$ to be lifts of the unit object of \mathcal{V} to a module of H . Together with an abstraction of group-like elements this allows us to state in Definition III.6.21 that pairs in involution of a Hopf monad consist of a group-like and a character implementing the square of the antipode by their adjoint action. An identification of certain monoidal natural transformations on \mathcal{V}^H with group-like elements of H leads to Theorem III.6.24: pairs in involution correspond to quasi-pivotal structures

on \mathcal{V}^H whose underlying invertible objects are characters of H . Furthermore, we prove in Theorem III.6.25 that morphisms of comodule monads between the anti-Drinfeld and Drinfeld double of H are in bijection with a particular kind of module functors from $\mathcal{Q}(\mathcal{V}^H)$ to $\mathcal{Z}(\mathcal{V}^H)$. With this, we get the monadic version of the Hajac–Sommerhäuser characterisation of pairs in involution:

Theorem 4 (Theorem III.6.26). *Let $H: \mathcal{V} \rightarrow \mathcal{V}$ be a Hopf monad on a pivotal category \mathcal{V} and assume that H admits a Drinfeld and anti-Drinfeld double. The following are equivalent:*

- (i) *The Hopf monad H admits a pair in involution.*
- (ii) *There exists a module over $Q(H)$ whose underlying object is $1 \in \mathcal{V}$.*
- (iii) *The Drinfeld and anti-Drinfeld double of H are isomorphic as monads.*

From this we obtain as a final result of the present dissertation a connection between the anti-Drinfeld double of a Hopf monad and certain pivotal structures. It is given in Corollary III.6.27.

Theorem 5. *Provided the necessary coends exist, a rigid category \mathcal{C} is pivotal if and only if there exists an isomorphism of monads between the Drinfeld and anti-Drinfeld double of the identity Hopf monad of \mathcal{C}*

Structure and outline of the thesis. The present thesis consists of three chapters, each corresponding to one of the following articles. Except from bundling the references into a single bibliography, only minor textual and typographical changes have been made in order to increase the coherence of the dissertation at hand.

- [HK19] Sebastian Halbig and Ulrich Krähmer. A Hopf algebra without modular pairs in involution. In *Geometric Methods in physics XXXVII*, 2019.
- [Hal21] Sebastian Halbig. Generalised Taft algebras. In *Communications in algebra*, 2021.
- [HZ22] Sebastian Halbig and Tony Zorman. Pivotality, twisted centres and the anti-double of a Hopf monad. (*preprint*) *arXiv:2201.05361*, 2022.

Chapter I considers special generalised Taft algebras, called the book Hopf algebras. In Theorem I.1.2 it is proven that while these Hopf algebras always admit a pair in involution, the modularity condition cannot be satisfied for certain choices of parameters.

This theory is extended considerably in Chapter II. Section II.1 provides an introduction to the theory of pairs in involution for finite-dimensional Hopf algebras. This is extended and made more precise in Section II.2. Generalised Taft algebras are introduced in Section II.3. The classification of such Hopf algebras without pairs in involution is the main content of Section II.4, see in particular Theorem II.4.5 and Theorem II.4.8. Examples of generalised Taft algebras without pairs in involution are discussed in Lemma II.4.10. The chapter is concluded in Section II.5, where the role of pairs in involution in representation theory is investigated.

Chapter III is a continuation of these considerations. In Section III.1, the Hajac–Sommerhäuser theorem is recalled and our strategy for generalising it is sketched.

Section III.2 provides a recollection of the necessary categorical tools for our study. A short discussion of heaps is given in Section III.3. The anti-Drinfeld centre and its connection with pivotal structures are investigated in Section III.4. We prove in Theorem III.4.14 a variant of the Hajac–Sommerhäuser theorem for rigid monoidal categories. Theorem III.4.23 explains how certain objects of the anti-Drinfeld centre induce pivotal structures on the Drinfeld centre. That this association is neither injective nor surjective is discussed in Remark III.4.24 and Theorem III.4.38.

We recall Hopf monads and comodule monads in Section III.5. Section III.6 merges the categorical with the Hopf monadic findings by developing the concept of the anti-central monad and the anti-Drinfeld double. The main result is Theorem III.6.26, a monadic version of the description of pairs in involution by Hajac and Sommerhäuser.

A HOPF ALGEBRA WITHOUT A MODULAR PAIR IN INVOLUTION

Sebastian Halbig and Ulrich Krähmer

2019

S.H., TECHNISCHE UNIVERSITÄT DRESDEN, INSTITUT FÜR GEOMETRIE, ZELLESCHER WEG 12–14, 01062 DRESDEN
EMAIL ADDRESS: Sebastian.Halbig@tu-dresden.de

U.K., TECHNISCHE UNIVERSITÄT DRESDEN, INSTITUT FÜR GEOMETRIE, ZELLESCHER WEG 12–14, 01062 DRESDEN
EMAIL ADDRESS: Ulrich.Kraehmer@tu-dresden.de

ABSTRACT. The aim of this short note is to communicate an example of a finite-dimensional Hopf algebra that does not admit a modular pair in involution in the sense of Connes and Moscovici.

Publication details:

Geometric methods in physics XXXVII, Trends Math., pages 140–142. Birkhäuser/Springer, Cham.

1. INTRODUCTION

The concept of a modular pair in involution was introduced by Connes and Moscovici, see [CM99] in order to define the Hopf-cyclic cohomology of a Hopf algebra H over a field \mathbb{k} . In the following we freely use standard notation from Hopf algebra theory e.g. as in [Mon93, Rad12]. In particular, H° is the Hopf dual of H and $\beta^{-1} = \beta \circ S$ is the convolution inverse of a group-like $\beta \in H^\circ$ (i.e. a character $\beta: H \rightarrow \mathbb{k}$).

Definition 1.1. Let H be a Hopf algebra. A pair (l, β) of group-like elements $l \in H, \beta \in H^\circ$ is a *modular pair in involution* if $\beta(l) = 1$ and

$$(1.1) \quad S^2(h) = \beta(h_{(3)})\beta^{-1}(h_{(1)})lh_{(2)}l^{-1}$$

holds for all $h \in H$.

Hajac et al. extended this notion to that of stable anti-Yetter–Drinfeld modules over Hopf algebras, see [HKRS04b]. It is also related to earlier work by Kauffman and Radford [KR93] who classified the ribbon elements in Drinfeld doubles of finite-dimensional Hopf algebras. Among their results they showed that if $\dim_{\mathbb{k}} H$ is odd and S^2 has odd order, then there is always a pair (l, β) implementing S^2 . The question arises whether there are also always pairs (l, β) that additionally satisfy the stability condition $\beta(l) = 1$. The aim of the present note is to point out that this is not the case in general:

Theorem 1.2. Let p be a prime number, $s \in \mathbb{Z}_p \setminus \{0\}$, $q \in \mathbb{k}$ be a primitive p -th root of unity, and H be the Hopf algebra with generators g, x, y and defining algebra and coalgebra relations

$$(1.2) \quad gx = qxg, \quad gy = q^{-s}yg, \quad g^p = 1, \quad x^p = y^p = 0, \quad xy = q^{-s}yx,$$

$$(1.3) \quad \Delta(g) = g \otimes g, \quad \Delta(x) = 1 \otimes x + x \otimes g, \quad \Delta(y) = 1 \otimes y + y \otimes g^s.$$

Its antipode is determined by

$$(1.4) \quad S(g) = g^{-1}, \quad S(x) = -xg^{-1}, \quad S(y) = -yg^{-s},$$

and H has a modular pair in involution if and only if $s \in \{0, 1, p-1\}$.

The Hopf algebra H appears naturally in several contexts. In particular, it is referred to as the book Hopf algebra in [AS98b].

Acknowledgements. We thank P.M. Hajac for pointing us to the question answered here.

2. PROOF

It is immediately verified that the group-likes in H are the elements of the form $l = g^i$ for some integer $i \in \mathbb{Z}_p$; furthermore, a character $\beta: H \rightarrow \mathbb{k}$, has to vanish on x, y and is determined by its value $\beta(g)$ which can be any p -th root of unity in \mathbb{k} (including 1, in which case $\beta = \varepsilon$ is the counit of H). Any such pair of a group-like and character induces an automorphism of H via

$$T_{(l, \beta)}: H \rightarrow H, \quad T_{(l, \beta)}(h) := \beta(h_{(1)})lh_{(2)}l^{-1}\beta^{-1}(h_{(3)})$$

It is determined by its values on the generators

$$T_{(l, \beta)}(g) = g, \quad T_{(l, \beta)}(x) = q^i\beta(g)x, \quad T_{(l, \beta)}(y) = q^{-is}\beta(g)^s y.$$

Comparing this with the square of the antipode

$$S^2(g) = g, \quad S^2(x) = g x g^{-1} = q x, \quad S^2(y) = g^s y g^{-s} = q^{-s^2} y$$

shows that $S^2 = T_{(l, \beta)}$ if and only if

$$\beta(g) = q^{1-i}, \quad \beta(g)^s = q^{s(i-s)}.$$

Assuming $\beta(g) = q^{1-i}$, the modularity condition translates to

$$\beta(l) = \beta(g)^i = q^{i(1-i)} = 1.$$

Furthermore, $\beta(g)^s = q^{s(i-s)}$ reduces to $q^{s(2i-s-1)} = 1$. Using the identification of the p -th roots of unity with \mathbb{Z}_p given by $q \mapsto 1$, we observe that (l, β) is a modular pair in involution if and only if modulo p we have

$$i(1-i) = 0 \quad \text{and} \quad s(2i-s-1) = 0.$$

For $i = 0$ this means $-s(s+1) = 0$ and for $i = 1$ it means $s(1-s) = 0$ in \mathbb{Z}_p . The claim follows. \square

GENERALISED TAFT ALGEBRAS AND PAIRS IN INVOLUTION

Sebastian Halbig

2021

S.H., TECHNISCHE UNIVERSITÄT DRESDEN, INSTITUT FÜR GEOMETRIE, ZELLESCHER WEG 12–14, 01062 DRESDEN
EMAIL ADDRESS: Sebastian.Halbig@tu-dresden.de

ABSTRACT. A class of finite-dimensional Hopf algebras which generalise the notion of Taft algebras is studied. We give necessary and sufficient conditions for these Hopf algebras to admit a pair in involution. That is, to not have a group-like and a character implementing the square of the antipode. As a consequence, we prove the existence of an infinite set of examples of finite-dimensional Hopf algebras without such pairs. Implications for the theory of anti-Yetter–Drinfeld modules as well as biduality of representations of Hopf algebras are discussed.

Publication details:

Communications in Algebra, 49(12), pages 5181–5195.

1. INTRODUCTION

Main result. A pair in involution for a Hopf algebra H over a field \mathbb{k} is a pair (l, β) of a group-like $l \in H$ and a character $\beta: H \rightarrow \mathbb{k}$ such that the square of the antipode is given by the conjugate action of l and β . In a vague sense, it can be imagined to be similar to a ‘square-root’ of Radford’s S^4 -formula. Often one additionally requires the pair to be modular, i.e. to satisfy $\beta(l) = 1$. Pairs in involution appear in many different contexts within Hopf algebra theory, reaching from Hopf-cyclic cohomology [CM99, HKRS04b, HS10] to knot invariants [KR93]. Kauffman and Radford showed in the aforementioned article that the square of the antipode of certain Taft algebras is not implemented by square-roots of the distinguished group-likes, see [KR93, Proposition 7]. Nonetheless, these Hopf algebras admit modular pairs in involution. In a previous work by Krähmer and the author, see [HK19], examples of Hopf algebras were given, whose pairs in involution do not satisfy the modularity condition. The paper at hand builds upon this result and proves the existence of finite-dimensional Hopf algebras without such pairs. Hereto, we introduce generalised Taft algebras, a class of Hopf algebras containing the examples of [HK19]. As algebras, these are generated by a group-like g and two twisted primitives x and y such that g spans a cyclic group and x and y are nilpotent. Moreover, the generators are required to commute up to some roots of unity. The details of this presentation are given in Theorem 3.14. For a generalised Taft algebras pairs in involution correspond to solutions of systems of Diophantine equations, see Theorem 4.5. The main result, Theorem 4.8, gives necessary and sufficient conditions for the non-existence of such solutions. In Lemma 4.10 we apply the above result to show that there are finite-dimensional Hopf algebras without these pairs. Additionally, Lemma 5.1 shows that Hopf algebras which are isomorphic only as algebras need not share the property of having a pair in involution.

Pivotal categories and anti-Yetter–Drinfeld modules. A pivotal category is a monoidal category with a notion of duality and a natural isomorphism between any object and its bidual which is compatible with the monoidal structure. An example are the finite-dimensional modules over pivotal Hopf algebras. As discussed in Section 5, a finite-dimensional Hopf algebra has a pair in involution if and only if its Drinfeld double is pivotal. Another way of describing this interplay is via anti-Yetter–Drinfeld modules, which arose in the field of Hopf-cyclic cohomology. Similar to Yetter–Drinfeld modules, they are simultaneously modules and comodules over a Hopf algebra with a compatibility condition between the action and coaction. For a finite-dimensional Hopf algebra one can construct an algebra called the anti-Drinfeld double, whose modules correspond to anti-Yetter–Drinfeld modules. The existence of a pair in involution is equivalent to the Drinfeld double and the anti-Drinfeld double being isomorphic as algebras. As a consequence of our findings there are examples where such an isomorphism does not exist. In this case the Drinfeld double is not a pivotal Hopf algebra.

Outline. This article is organised as follows. Section 2 serves as a summary of the theory of pairs in involution with a focus on finite-dimensional Hopf algebras. In Section 3 we introduce the main object of our study, generalised Taft algebras, and give an ‘easy-to-work-with’ presentation. The classification of all of these Hopf algebras admitting a pair in involution is carried out in Section 4. Afterwards we discuss examples of Hopf algebras with and without such pairs. We conclude the

paper with Section 5, where we apply our results to the context of representation theory.

Acknowledgements. The author would like to thank P. Hajac for his kind invitation to IMPAN. He would also like to thank I. Heckenberger and U. Krähmer for many stimulating discussions.

2. PAIRS IN INVOLUTION

We work over an algebraically closed field \mathbb{k} of characteristic zero; ‘dim’ and ‘ \otimes ’ ought to be understood as dimension and tensor product over \mathbb{k} . Standard notation for Hopf algebras, as in e.g. [Mon93, Rad12], is freely used. Given a Hopf algebra H we write $\text{Gr}(H)$ for its group of group-likes, $\text{Pr}(H)$ for its space of primitive elements and H° for its (finite) dual Hopf algebra. The antipode of H is denoted by $S: H \rightarrow H$, its counit by $\epsilon: H \rightarrow \mathbb{k}$ and its coproduct by $\Delta: H \rightarrow H \otimes H$. For calculations involving the coproduct of H or the coaction of some comodule M over H we rely on reduced Sweedler notation. For example we write $h_{(1)} \otimes h_{(2)} := \Delta(h)$ for $h \in H$. An element $x \in H$ whose coproduct is $\Delta(x) = 1 \otimes x + x \otimes g$, for $g \in \text{Gr}(H)$ a group-like, is called a twisted primitive.

Modular pairs in involution play the role of coefficients for Hopf-cyclic cohomology as introduced by Connes and Moscovici [CM99]. Later on, it was realised by Hajac et al. [HKRS04a] that this notion can be extended to that of (stable) anti-Yetter–Drinfeld modules, which we discuss in Section 3.

Definition 2.1. Let H be a Hopf algebra over \mathbb{k} . A pair (l, β) comprising group-like elements $l \in \text{Gr}(H)$ and $\beta \in \text{Gr}(H^\circ)$ is a *pair in involution* if it satisfies the antipode condition

$$(AC) \quad S^2(h) = \beta(h_{(3)})\beta^{-1}(h_{(1)})lh_{(2)}l^{-1}, \quad \text{for all } h \in H.$$

If additionally the modularity condition

$$(MC) \quad \beta(l) = 1$$

holds, it is called a *modular pair in involution*.

A *left integral* of a Hopf algebra H is an element $\Lambda \in H$ such that $h\Lambda = \epsilon(h)\Lambda$ for all $h \in H$. If H is finite-dimensional, its left integrals form a one-dimensional subspace $L(H) \subset H$. There is a unique group-like $\alpha \in \text{Gr}(H^\circ)$ such that $\Lambda h = \alpha(h)\Lambda$ for all $\Lambda \in L(H)$ and $h \in H$. It is called the *distinguished group-like* of H° . Radford proved that the fourth power of the antipode is implemented by the distinguished group-likes of a Hopf algebra and its dual [Rad76].

Theorem 2.2 (Radford’s S^4 -formula). *Let H be a finite-dimensional Hopf algebra and $g \in \text{Gr}(H)$, $\alpha \in \text{Gr}(H^\circ)$ the distinguished group-likes of H and H° . Then the fourth power of the antipode is given by*

$$(2.1) \quad S^4(h) = \alpha(h_3)\alpha^{-1}(h_{(1)})g^{-1}h_{(2)}g, \quad \text{for all } h \in H.$$

In their paper on the classification of ribbon elements of Drinfeld doubles Kauffman and Radford studied ‘square roots’ of the distinguished group-likes to obtain a formula for the square of the antipode, see [KR93]. The next lemma follows from [KR93, Proposition 6].

Lemma 2.3. *Let H be a pointed Hopf algebra, i.e. a Hopf algebra whose simple comodules are one-dimensional. If the dimension of H is odd, it has a pair in involution (l, β) such that $g := l^{-2}$ and $\alpha := \beta^2$ are the distinguished group-likes of H and H° , respectively.*

Let us conclude this section with a remark on the representation theoretic viewpoint on pairs in involution. Given a finite-dimensional Hopf algebra H one can associate to it its category of finite-dimensional Yetter–Drinfeld modules, see Section 3.1. It is a *rigid* category; i.e it is monoidal together with a notion of duality compatible with its monoidal structure. In this context a pair in involution corresponds to, and can be reconstructed from, a *monoidal* natural isomorphism between the identity functor and the functor which maps objects and morphisms to their biduals. A rigid category admitting such a structure is called *pivotal*. In Section 5 we will discuss the correspondence between pairs in involution and the pivotality of Yetter–Drinfeld modules.

3. GENERALISED TAFT ALGEBRAS

The strategy behind defining generalised Taft algebras is as follows. Fix a finite cyclic group G . Choose a Yetter–Drinfeld module V over the group algebra $\mathbb{k}G$ whose braiding is subject to certain relations. The bosonisation of the Nichols algebra of V along $\mathbb{k}G$ yields another Hopf algebra. This will be referred to as the coopposite of a generalised Taft algebra, see Definition 3.11. A presentation in terms of generators and relations is obtained in Theorem 3.14.

3.1. Yetter–Drinfeld and anti-Yetter–Drinfeld modules. Unless stated otherwise, every Hopf algebra in this section is assumed to have an invertible antipode.

The next Definition agrees with [EGNO15, Definition 7.15.2].

Definition 3.1. A *Yetter–Drinfeld module* over a Hopf algebra H is a \mathbb{k} -vector space M together with a module structure $\triangleright : H \otimes M \rightarrow M$ and a comodule structure $\delta : M \rightarrow H \otimes M$ satisfying the compatibility condition

$$(YD) \quad \delta(h \triangleright m) = h_{(1)} m_{(-1)} S(h_{(3)}) \otimes h_{(2)} \triangleright m_{(0)}, \quad \forall h \in H, m \in M.$$

A linear map $f : M \rightarrow N$ between Yetter–Drinfeld modules is called a *morphism of Yetter–Drinfeld modules* if it is both a module and comodule morphism.

Remark 3.2. The Yetter–Drinfeld modules over a Hopf algebra H form the category ${}^H_H\mathcal{YD}$. The diagonal action and coaction of H define a monoidal structure on it, see [EGNO15, Chapter 7.15]. If the antipode of H is invertible, the natural isomorphism

$$(3.1) \quad \sigma_{M,N} : M \otimes N \rightarrow N \otimes M, \quad m \otimes n \mapsto m_{(-1)} \triangleright n \otimes m_{(0)}.$$

turns ${}^H_H\mathcal{YD}$ into a *braided category*. This is explained in Chapters 7 and 8 of [EGNO15]. Yetter–Drinfeld modules over a finite-dimensional Hopf algebra H coincide with modules over its *Drinfeld double* $D(H)$, see [Kas95, Chapter IX]⁶.

⁶ The definition of the Drinfeld and anti-Drinfeld double given here varies from [Kas95, Chapter IX.4] and [HKRS04b, Proposition 4.1] to accommodate our choice of (anti-)Yetter–Drinfeld modules. In terms of the literature listed above our definition would read as $D(H^{\text{cop}})^{\text{cop}}$ and $A(H^{\text{cop}})^{\text{cop}}$.

It is the vector space $H^\circ \otimes H$ whose Hopf algebra structure is for $g, h \in H$ and $\alpha, \beta \in H^\circ$ defined by

$$\begin{aligned} (\alpha \otimes g)(\beta \otimes h) &:= \beta_{(1)}(S(g_{(1)}))\beta_{(3)}(g_{(3)})\beta_{(2)}\alpha \otimes g_{(2)}h, \\ \text{(DD)} \quad \Delta(\alpha \otimes g) &:= (\alpha_{(1)} \otimes g_{(1)}) \otimes (\alpha_{(2)} \otimes g_{(2)}), \\ S(\alpha \otimes g) &:= \alpha_{(1)}(g_{(1)})\alpha_{(3)}(S(g_{(3)}))S^{-1}(\alpha_{(2)}) \otimes S(g_{(2)}). \end{aligned}$$

Remark 3.3. The *anti-Drinfeld double* $A(H)$ of a finite-dimensional Hopf algebra H was introduced in [HKRS04b, Proposition 4.1]⁶. It is a comodule algebra over the Drinfeld double $D(H)$. As a vector space it is $H^\circ \otimes H$. The multiplication and coaction are given by

$$\begin{aligned} \text{(ADD)} \quad (\alpha \otimes g)(\beta \otimes h) &:= \beta_{(1)}(S(g_{(1)}))\beta_{(3)}(S^{-2}(g_{(3)}))\beta_{(2)}\alpha \otimes g_{(2)}h, \\ \delta(\alpha \otimes g) &:= (\alpha_{(1)} \otimes g_{(1)}) \otimes (\alpha_{(2)} \otimes g_{(2)}), \end{aligned}$$

for $g, h \in H$ and $\alpha \in H^\circ$. Modules over $A(H)$ correspond to *anti-Yetter–Drinfeld modules*, see [HKRS04b, Definition 2.1]. That is, triples $(M, \triangleright, \delta)$ comprising a vector space M , an action $\triangleright : H \otimes M \rightarrow M$ and a coaction $\delta : M \rightarrow H \otimes M$ such that

$$\text{(AYD)} \quad \delta(h \triangleright m) = h_{(1)}m_{(-1)}S^{-1}(h_{(3)}) \otimes h_{(2)} \triangleright m_{(0)}, \quad \forall h \in H, m \in M.$$

In general, anti-Yetter–Drinfeld modules do not form a monoidal category but a module category over the Yetter–Drinfeld modules [HKRS04b, Lemma 2.3].

Our interest in anti-Yetter–Drinfeld modules is due to the following unpublished result by Hajac and Sommerhäuser. We include a proof for the reader's convenience.

Theorem 3.4. *Suppose H to be a finite-dimensional Hopf algebra. The following are equivalent:*

- (i) *The Hopf algebra H admits a pair in involution.*
- (ii) *There exists an anti-Yetter–Drinfeld module with \mathbb{k} -dimension one.*
- (iii) *The Drinfeld and anti-Drinfeld double of H are isomorphic as algebras.*

Proof. We start with (iii) \implies (ii): Assume $f : A(H) \rightarrow D(H)$ to be an isomorphism of algebras. The ground field \mathbb{k} considered as the trivial $D(H)$ -module becomes a one-dimensional $A(H)$ -module by pulling back the action along f .

(ii) \implies (i) : Let $(\mathbb{k}, \triangleright, \delta)$ be a one-dimensional anti-Yetter–Drinfeld module. Its action and coaction are implemented by group-like elements $\beta^{-1} \in \text{Gr}(H^\circ)$ and $l \in \text{Gr}(H)$. We identify $H \cong H \otimes \mathbb{k}$ and observe

$$(3.2) \quad \beta^{-1}(h_{(2)})S(h_{(1)})l = S(h_{(1)})\delta(h_{(2)} \triangleright 1) \stackrel{\text{(AYD)}}{=} \beta^{-1}(h_{(1)})lS^{-1}(h_{(2)}) \quad \forall h \in H.$$

Applying S to both sides of Equation (3.2) shows that (l, β) is a pair in involution.

(i) \implies (iii) : Given a pair in involution (l, β) we define the linear map $f : A(H) \rightarrow D(H)$, $\alpha \otimes g \mapsto \alpha_{(2)}(l)\beta^{-1}(g_{(2)}) \alpha_{(1)} \otimes g_{(1)}$ and compute for all elements $(\alpha \otimes g), (\gamma \otimes h) \in A(H)$:

$$\begin{aligned} f((\alpha \otimes g)(\gamma \otimes h)) &= \gamma_{(1)}(S(g_{(1)}))\gamma_{(3)}(S^{-2}(g_{(3)})) f(\gamma_{(2)}\alpha \otimes g_{(2)}h) \\ &= \gamma_{(1)}(S(g_{(1)}))\gamma_{(4)}(S^{-2}(g_{(4)}))\gamma_{(3)}(l)\alpha_{(2)}(l)\beta^{-1}(g_{(3)})\beta^{-1}(h_{(2)}) \gamma_{(2)}\alpha_{(1)} \otimes g_{(2)}h_{(1)} \\ &= \gamma_{(1)}(S(g_{(1)}))\gamma_{(3)}(\beta^{-1}(g_{(3)})lS^{-2}(g_{(4)})) \alpha_{(2)}(l)\beta^{-1}(h_{(2)}) \gamma_{(2)}\alpha_{(1)} \otimes g_{(2)}h_{(1)} \\ &\stackrel{\text{(AC)}}{=} \gamma_{(1)}(S(g_{(1)}))\gamma_{(3)}(g_{(3)})\gamma_{(4)}(l)\alpha_{(2)}(l)\beta^{-1}(g_{(4)})\beta^{-1}(h_{(2)}) \gamma_{(2)}\alpha_{(1)} \otimes g_{(2)}h_{(1)} \\ &= f((\alpha \otimes g))f((\gamma \otimes h)). \end{aligned}$$

This proves f to be a morphism of algebras. Its inverse is $f^{-1}: D(H) \rightarrow A(H)$, $\alpha \otimes g \mapsto \alpha_{(2)}(l^{-1})\beta(g_{(2)}) \alpha_{(1)} \otimes g_{(1)}$. \square

Our next result shows that the existence of a pair in involution corresponds to a suitably strong notion of Morita equivalence between the Drinfeld and anti-Drinfeld double. Given an algebra A we write $U_A: A\text{-Bimod} \rightarrow A\text{-Mod}$ for the forgetful functor from the category of bimodules over A to the category of left A -modules.

Lemma 3.5. *Let H be a finite-dimensional Hopf algebra. It is equivalent:*

- (i) H has a pair in involution.
- (ii) There are \mathbb{k} -linear equivalences of categories $F: D(H)\text{-Mod} \rightarrow A(H)\text{-Mod}$ and $G: D(H)\text{-Bimod} \rightarrow A(H)\text{-Bimod}$ such that a natural isomorphism $\eta: F U_{D(H)} \rightarrow U_{A(H)} G$ exists.

Proof. Suppose H has a pair in involution. By Theorem 3.4 there exists an isomorphism of algebras $f: A(H) \rightarrow D(H)$. Let $F: D(H)\text{-Mod} \rightarrow A(H)\text{-Mod}$ be the functor that identifies modules over $D(H)$ with modules over $A(H)$ by pulling back the action along f and define $G: D(H)\text{-Bimod} \rightarrow A(H)\text{-Bimod}$ likewise. Both, F and G are \mathbb{k} -linear equivalences of categories and $F U_{D(H)} = U_{A(H)} G$.

Conversely, assume F , G and η to be as described above. Let $X_{\text{bi}} := (X, \triangleright, \triangleleft)$ be a bimodule over $D(H)$. Set $X_1 := U_{D(H)}(X_{\text{bi}}) = (X, \triangleright)$ and write $Y := F(X_1)$. The module endomorphisms $\text{End}_{A(H)}(Y)$ themselves become a module over $A(H)$ via

$$\tilde{\diamond}: A(H) \otimes \text{End}_{A(H)}(Y) \rightarrow \text{End}_{A(H)}(Y), \quad (a \tilde{\diamond} \phi)(x) := \phi(\eta_{X_{\text{bi}}}^{-1}(\eta_{X_{\text{bi}}}(x) \triangleleft a)).$$

As F is a \mathbb{k} -linear equivalence of categories $\text{End}_{D(H)}(X_1) \cong \text{End}_{A(H)}(Y)$ as \mathbb{k} -vector spaces. Choose $X_{\text{bi}} := \mathbb{k}_\epsilon$ to be the trivial bimodule over $D(H)$. Then $X_1 = \mathbb{k}$ is the trivial $D(H)$ -module and $\text{End}_{A(H)}(F(\mathbb{k}))$ is a one-dimensional module over $A(H)$. The existence of a pair in involution follows from Theorem 3.4. \square

3.2. Nichols algebras and bosonisations. We follow the survey articles [AS02, AA17] in recalling some aspects of Nichols algebras of diagonal type. Until the end of this subsection we fix a Hopf algebra H with invertible antipode.

The definition of Hopf algebras generalises naturally to braided monoidal categories. A Hopf algebra R in the category of Yetter–Drinfeld modules over some Hopf algebra H is referred to as a *braided* Hopf algebra. Our next definition follows [AS02, Definition 2.1] almost verbatim.

Definition 3.6. Let V be a Yetter–Drinfeld module over H . A *Nichols algebra* of V is a braided graded Hopf algebra $\mathcal{B}(V) = \bigoplus_{n \geq 0} \mathcal{B}(V)_n \in {}^H_H \mathcal{YD}$ satisfying

- (i) $\mathcal{B}(V)_0 = \mathbb{k}$,
- (ii) $\mathcal{B}(V)_1 = \text{Pr}(\mathcal{B}(V)) \cong V$, and
- (iii) $\mathcal{B}(V)$ is generated as an algebra by $\mathcal{B}(V)_1$.

Proposition 2.2 of [AS02] asserts the existence of Nichols algebras and their uniqueness up to isomorphism. By abuse of notation we will speak of *the* Nichols algebra in the following. As explained in [AS02, Definition 1.6], different types of Nichols algebras are distinguished in terms of their braidings.

Definition 3.7. Let V be a θ -dimensional Yetter–Drinfeld module over H . Write $\sigma := \sigma_{V,V}: V \otimes V \rightarrow V \otimes V$ for its braiding. An ordered \mathbb{k} -basis $\{v_1, \dots, v_\theta\}$ of V is said to be of *diagonal type* if

$$(3.3) \quad \sigma(v_i \otimes v_j) = \mathfrak{q}_{ij} v_j \otimes v_i, \quad \mathfrak{q}_{ij} \in \mathbb{k} \text{ for } 1 \leq i, j \leq \theta.$$

Accordingly, V and $\mathcal{B}(V)$ are referred to be of diagonal type if V has an ordered basis of diagonal type. The matrix $(\mathfrak{q}_{ij}) \in \mathbb{k}^{\theta \times \theta}$ is called the *matrix of the braiding*.

Finite-dimensional Nichols algebras of diagonal type were classified by Heckenberger in terms of generalised Dynkin diagrams, see [Hec09]. The Nichols algebra part of a generalised Taft algebra corresponds to a diagram of $A_1 \times A_1$ -type.

Definition 3.8. A Yetter–Drinfeld module V over H is of $A_1 \times A_1$ -type if a basis of diagonal type exists whose matrix of the braiding $(\mathfrak{q}_{ij}) \in \mathbb{k}^{2 \times 2}$ satisfies:

$$(3.4) \quad \text{Its entries are roots of unity, } \mathfrak{q}_{11}, \mathfrak{q}_{22} \neq 1 \text{ and } \mathfrak{q}_{12}\mathfrak{q}_{21} = 1.$$

Likewise, its Nichols algebra $\mathcal{B}(V)$ is also referred to as of $A_1 \times A_1$ -type.

Nichols algebras of $A_1 \times A_1$ -type are also called *quantum planes*, see [AS98a].

Remark 3.9. A direct computation shows that whether a Yetter–Drinfeld module is of $A_1 \times A_1$ -type does not depend on the choice of basis of diagonal type.

The bosonisation or biproduct of a braided Hopf algebra R over H equips the vector space $R \otimes H$ with the structure of a Hopf algebra, see [Rad12, Theorems 11.5.7 and 11.6.9]. To distinguish between the coaction and comultiplication of R we use a slight variation of Sweedler notation and write $r^{(1)} \otimes r^{(2)} := \Delta(r)$ for $r \in R$.

Definition 3.10. Let H be a Hopf algebra whose antipode is invertible and R a braided Hopf algebra in ${}^H_H\mathcal{YD}$. The *bosonisation* of R by H is the Hopf algebra $R\#H$, whose underlying vector space is $R \otimes H$ and whose multiplication, comultiplication and antipode is defined for $g, h \in H$ and $r, s \in R$ by

$$(3.5) \quad \begin{aligned} (r \otimes g)(s \otimes h) &:= r(g_{(1)} \triangleright s) \otimes g_{(2)}h, \\ \Delta(r \otimes g) &:= r^{(1)} \otimes (r^{(2)})_{(-1)}g_{(1)} \otimes (r^{(2)})_{(0)} \otimes g_{(2)}, \\ S(r \otimes g) &:= S_H(r_{(-2)}g_{(2)}) \triangleright S_R(r_{(0)}) \otimes S_H(r_{(-1)}g_{(1)}). \end{aligned}$$

3.3. Generalised Taft algebras. We define now the main object under investigation, generalised Taft algebras. In Theorem 3.14 we obtain a presentation in terms of generators and relations.

Definition 3.11. Let V be a Yetter–Drinfeld module of $A_1 \times A_1$ -type over the group algebra $\mathbb{k}G$ of a finite cyclic group G . We call $(\mathcal{B}(V)\#\mathbb{k}G)^{\text{cop}}$ a *generalised Taft algebra*.

In the above definition the coopposite is chosen to match the definition of Taft algebras as given for example in [KR93, p. 113].

Let $N \geq 2$ be a natural number. We write $\mathbb{Z}_N := \mathbb{Z}/N\mathbb{Z}$.

Definition 3.12. A matrix $(a_{ij}) \in \mathbb{Z}_N^{2 \times 2}$ whose entries satisfy modulo N

$$(3.6) \quad a_{11}a_{12} \neq 0, \quad a_{21}a_{22} \neq 0, \quad a_{11}a_{22} + a_{12}a_{21} = 0$$

is called a *parameter matrix* of a generalised Taft algebra.

Parameter matrices allow us to define Yetter–Drinfeld modules of $A_1 \times A_1$ -type.

Lemma 3.13. *Let $N \geq 2$ and $(a_{ij}) \in \mathbb{Z}_N^{2 \times 2}$. Fix a generator $g \in \mathbb{Z}_N$ and a primitive N -th root of unity $q \in \mathbb{k}$. The Yetter–Drinfeld module $V := \text{span}_{\mathbb{k}}\{x, y\}$, defined by*

$$(3.7) \quad \delta(x) := g^{a_{11}}x, \quad \delta(y) := g^{a_{21}}y, \quad g \triangleright x := q^{a_{12}}x, \quad g \triangleright y := q^{a_{22}}y,$$

generates a generalised Taft algebra $(\mathcal{B}(V) \# \mathbb{k}\mathbb{Z}_N)^{\text{cop}}$ if and only if (a_{ij}) is a parameter matrix.

Proof. The matrix of the braiding of V is, with respect to the ordered basis $\{x, y\}$, given by $q_{ij} := q^{a_{j1}a_{i2}}$. Identifying q with a generator of \mathbb{Z}_N shows that V is of $A_1 \times A_1$ -type if and only if (a_{ij}) is a parameter matrix. \square

Given a matrix $(a_{ij}) \in \mathbb{Z}_N^{2 \times 2}$, we write $N_x := \text{ord}(a_{11}a_{12})$ and $N_y := \text{ord}(a_{21}a_{22})$ for the orders of $a_{11}a_{12}$ and $a_{21}a_{22}$ in \mathbb{Z}_N , respectively.

Theorem 3.14. *Let H be a generalised Taft algebra. Then there exists an integer $N \geq 2$, a parameter matrix $(a_{ij}) \in \mathbb{Z}_N^{2 \times 2}$ and a primitive N -th root of unity $q \in \mathbb{k}$ such that H is generated by elements $g, x, y \in H$ subject to the relations*

$$(3.8a) \quad x^{N_x} = 0, \quad y^{N_y} = 0, \quad xy = q^{a_{11}a_{22}}yx,$$

$$(3.8b) \quad g^N = 1, \quad gx = q^{a_{12}}xg, \quad gy = q^{a_{22}}yg,$$

$$(3.8c) \quad \Delta(g) = g \otimes g, \quad \Delta(x) = 1 \otimes x + x \otimes g^{a_{11}}, \quad \Delta(y) = 1 \otimes y + y \otimes g^{a_{21}},$$

$$(3.8d) \quad S(g) = g^{-1}, \quad S(x) = -xg^{-a_{11}}, \quad S(y) = -yg^{-a_{21}}.$$

Proof. By definition $H = (\mathcal{B}(V) \# \mathbb{k}\mathbb{Z}_N)^{\text{cop}}$ for some $N \geq 2$. We fix a generator $\bar{g} \in \mathbb{Z}_N$ and a primitive N -th root of unity $q \in \mathbb{k}$. As a vector space V admits an ordered basis $\{\bar{x}, \bar{y}\}$ such that a matrix $(a_{ij}) \in \mathbb{Z}_N^{2 \times 2}$ exists which implements the action and coaction as in Equation (3.7), see [AS02, Remark 1.5]. The preceding lemma shows that (a_{ij}) needs to be a parameter matrix. Every element $z \otimes h \in H$ can be factorised into the product $(z \otimes 1)(1 \otimes h)$, for $z \in \mathcal{B}(V)$ and $h \in \mathbb{k}\mathbb{Z}_N$, implying that $g := 1 \otimes \bar{g}$, $x := \bar{x} \otimes 1$ and $y := \bar{y} \otimes 1$ generate H . The relations (3.8a) follow from [Hec07, Corollary 8.1]. The definition of the multiplication of bosonisations and $\bar{g}^N = 1$ imply the relations (3.8b). The coproduct and antipode of the generators are obtained by the respective formulas in Definition 3.10. \square

Convention. We fix some of the notation of this section. From now onwards $N \geq 2$ denotes an integer and $1 \neq q \in \mathbb{k}$ a primitive N -th root of unity. We write $A := (a_{ij}) \in \mathbb{Z}_N^{2 \times 2}$ for a parameter matrix and $H := H_q(A)$ for its associated generalised Taft algebra, generated by elements g, x and y . In particular, g generates the group $\text{Gr}(H)$ and x and y are nilpotent of degree N_x and N_y , respectively.

4. HOPF ALGEBRAS WITHOUT PAIRS IN INVOLUTION

We show that similar to Taft algebras their generalisations form a class of basic, pointed Hopf algebras, which is closed under duality. Our main result, Theorem 4.8, states necessary and sufficient conditions for these Hopf algebras to admit pairs in involution. Thereafter, we investigate how various properties of generalised Taft algebras affect the existence of such pairs. In Lemma 4.10 we construct an infinite family of examples of finite-dimensional Hopf algebras without pairs in involution.

4.1. Properties of generalised Taft algebras. To prove that the class of generalised Taft algebras is closed under duality, we identify generators of the dual. For a generalised Taft algebra $H := H_q(A)$, generated by $g, x, y \in H$, we specify linear maps $\xi, \psi, \phi: H \rightarrow \mathbb{k}$ by their values on the basis $\{x^i y^j g^l \mid 0 \leq i, j, l \leq N_x, N_y, N\}$ of H :

$$(4.1) \quad \begin{aligned} \xi(x^i y^j g^l) &= q^{-l} \delta_{i=j=0}, & \psi(x^i y^j g^l) &= q^{-a_{12}l} \delta_{i=1, j=0}, \\ \phi(x^i y^j g^l) &= q^{-a_{22}l} \delta_{i=0, j=1}. \end{aligned}$$

Given a matrix $A \in \mathbb{Z}_N^{2 \times 2}$ we write A_{21} for the matrix obtained by interchanging the first with the second column of A . The next result is implied by [Nen04, Proposition 3.1].

Theorem 4.1. *Let $H := H_q(A)$ be a generalised Taft algebra and write \bar{g}, \bar{x} and \bar{y} for the generators of $H_q(A_{21})$. There is an isomorphism of Hopf algebras $\Theta: H_q(A_{21}) \rightarrow H^\circ$ defined by $\Theta(\bar{g}) = \xi$, $\Theta(\bar{x}) = \psi$ and $\Theta(\bar{y}) = \phi$.*

A Hopf algebra is called *pointed* if every simple comodule is one-dimensional; if every simple module is one-dimensional it is called *basic*.

Lemma 4.2. *Generalised Taft algebras are pointed and basic.*

Proof. The first claim follows from [Rad12, Proposition 4.4.9]. The second is a consequence of the former one and Theorem 4.1. \square

We determine the left integrals and distinguished group-likes of generalised Taft algebras. The latter will prove useful in the study of the square of the antipode. This is a standard exercise, see for example [AA17, Section 2.12].

Lemma 4.3. *Let $H := H_q(A)$ be a generalised Taft algebra. The left integrals of H and H° are up to scalar multiplication*

$$\Lambda := \left(\sum_{i=0}^{N-1} g^i \right) x^{N_x-1} y^{N_y-1} \in H \text{ and } \Upsilon := \left(\sum_{i=0}^{N-1} \xi^i \right) \psi^{N_x-1} \phi^{N_y-1} \in H^\circ.$$

The elements $\xi^{-(a_{12}+a_{22})} \in H^\circ$ and $g^{-(a_{11}+a_{21})} \in H$ are the distinguished group-likes of H° and H , respectively.

Proof. By multiplying Λ with the generators of H we see that it is a left integral and that $\xi^{a_{12}(N_x-1)+a_{22}(N_y-1)}$ is the distinguished group-like of H° . Modulo N we have $a_{12}N_x = a_{22}N_y = 0$ and therefore $\xi^{a_{12}(N_x-1)+a_{22}(N_y-1)} = \xi^{-(a_{12}+a_{22})}$. The results for H° follow by applying the isomorphism of Theorem 4.1. \square

The motivation behind Kauffman's and Radford's study of the square of the antipode, see [KR93], was understanding Hopf algebras which give rise to knot invariants. This necessarily requires the Hopf algebra to be *quasitriangular*. That is, roughly speaking, an encoding of the notion of braidings on the level of Hopf algebras, see [Kas95, Chapters VIII and XIII]. The next Lemma is implied by Theorem 3.4 of [Nen04].

Lemma 4.4. *Let $H := H_q(A)$ be a generalised Taft algebra with generators g, x, y . Recall that $N_x, N_y \in \mathbb{N}$ were the minimal positive integers such that $x^{N_x} = 0$ and $y^{N_y} = 0$. Then H is quasitriangular if and only if N is divisible by 2, $N_x = N_y = 2$ and $a_{11} = a_{21} = \frac{N}{2}$.*

4.2. Pairs in involution as solutions of Diophantine equations. To find necessary and sufficient criteria for generalised Taft algebras to not admit a pair in involution we study the behaviour of the square of the antipode. Fix a generalised Taft algebra $H := H_q(A)$. Its square of the antipode is determined by

$$S^2(g) = g, \quad S^2(x) = q^{a_{11}a_{12}}x, \quad S^2(y) = q^{a_{21}a_{22}}y.$$

Likewise, the fourth power of the antipode is

$$S^4(g) = g, \quad S^4(x) = q^{2a_{11}a_{12}}x, \quad S^4(y) = q^{2a_{21}a_{22}}y.$$

Now, consider the family of Hopf algebra automorphisms $T_{(l,\beta)}: H \rightarrow H$ which is indexed by a pair of group-likes $l \in \text{Gr}(H)$, $\beta \in \text{Gr}(H^\circ)$ and defined via

$$T_{(l,\beta)}(h) = \beta(h_{(3)})\beta^{-1}(h_{(1)})lh_{(2)}l^{-1}, \quad \text{for all } h \in H.$$

Definition 2.1 states that H has a pair in involution if and only if there exists a pair of group-like elements (l, β) such that $T_{(l,\beta)} = S^2$. Every group-like $l \in \text{Gr}(H)$ and character $\beta \in \text{Gr}(H^\circ)$ can uniquely be written as $l = g^d$ and $\beta = \xi^{-c}$ with $c, d \in \mathbb{Z}_N$. Evaluating $T_{(g^d, \xi^{-c})}$ on the generators yields

$$T_{(g^d, \xi^{-c})}(g) = g, \quad T_{(g^d, \xi^{-c})}(x) = q^{a_{11}c + a_{12}d}x, \quad T_{(g^d, \xi^{-c})}(y) = q^{a_{21}c + a_{22}d}y.$$

Identifying the N -th roots of unity with \mathbb{Z}_N via $q \mapsto 1$ implies our next theorem.

Theorem 4.5. *Let q be a primitive N -th root of unity. A generalised Taft algebra $H_q(A)$ has a pair in involution if and only if $c, d \in \mathbb{Z}_N$ exist such that modulo N*

$$(4.2) \quad a_{11}c + a_{12}d = a_{11}a_{12}, \quad a_{21}c + a_{22}d = a_{21}a_{22}.$$

The pair is modular if and only if it additionally satisfies modulo N

$$(4.3) \quad cd = 0.$$

Remark 4.6. Lemma 4.3 and the discussion prior to the above theorem imply that for a given parameter matrix $(a_{ij}) \in \mathbb{Z}_N^{2 \times 2}$ of a generalised Taft algebra the integers $c' := a_{12} + a_{22}$, and $d' := a_{11} + a_{21}$ satisfy modulo N

$$a_{11}c' + a_{12}d' = 2a_{11}a_{12}, \quad a_{21}c' + a_{22}d' = 2a_{21}a_{22}.$$

If N is odd, 2 is invertible modulo N . In this case (4.2) has a solution.

Consequently, a generalised Taft algebra without pairs in involution necessarily needs to have a group of group-likes of even order N . In fact, the existence of such a pair depends on the behaviour of the entries of the parameter matrix modulo 2^n , where $n \in \mathbb{N}_0$ is the maximal integer such that 2^n divides N .

Definition 4.7. Suppose $2^n \cdot j \geq 2$, with j odd, and let $(a_{ij}) \in \mathbb{Z}_{2^n j}^{2 \times 2}$ be a parameter matrix of a generalised Taft algebra. The *matrix of powers* associated to (a_{ij}) is the matrix $(\mathbf{a}_{ij}) \in \mathbb{N}_0^{2 \times 2}$ whose entries are the minimal non-negative integers satisfying

$$(4.4) \quad 2^{\mathbf{a}_{ij}} \mu_{ij} = a_{ij} \pmod{2^n}, \quad \text{for } \mu_{ij} \in \mathbb{Z}_{2^n} \text{ invertible or zero.}$$

The matrix $(\mu_{ij}) \in \mathbb{Z}_{2^n}^{2 \times 2}$ is called the *matrix of coefficient* of (a_{ij}) . The *power of the coefficient matrix* is the minimal integer $\tau \in \mathbb{N}_0$ such that $2^\tau \nu = \det(\mu_{ij})$ modulo 2^n , with $\nu \in \mathbb{Z}_{2^n}$ invertible or zero.

Theorem 4.8. *Suppose $2^n \cdot j \geq 2$, with j odd. Let $q \in \mathbb{k}$ be a primitive $2^n j$ -th root of unity and (a_{ij}) a parameter matrix whose matrices of powers and coefficients are (\mathbf{a}_{ij}) and (μ_{ij}) , respectively. Write τ for the power of (μ_{ij}) . It is equivalent:*

- (i) $H_q(a_{ij})$ has no pair in involution,
(ii) $n \geq 1$, $\mu_{ij} \neq 0$ for $1 \leq i, j \leq 2$, $\mathbf{a}_{11} + \mathbf{a}_{22} < n$, $\mathbf{a}_{11} \neq \mathbf{a}_{21}$ and either $\tau > \min\{\mathbf{a}_{ij} \mid 1 \leq i, j \leq 2\}$ or $\det(\mu_{ij}) = 0$ modulo 2^n .

Proof. We prove H having a pair in involution equivalent to at least one of the above conditions not being met. By Theorem 4.5 this amounts in solving

$$(4.5) \quad \left(\begin{array}{cc|c} a_{11} & a_{12} & a_{11}a_{12} \\ a_{21} & a_{22} & a_{21}a_{22} \end{array} \right)$$

modulo $2^n j$. As $\chi: \mathbb{Z}_{2^n j} \rightarrow \mathbb{Z}_j \times \mathbb{Z}_{2^n}$, $(x \bmod 2^n \cdot j) \mapsto (x \bmod j, x \bmod 2^n)$ is an isomorphism of rings this is equivalent to the solvability of the above equation modulo j and modulo 2^n , respectively. In Remark 4.6 a solution modulo j was given. Thus, H has a pair in involution if and only if Equation (4.5) is solvable modulo 2^n . If $n = 0$, this is trivially the case. Hence, we assume $n \geq 1$. Using the matrices of powers and coefficients, Equation (4.5) can be expressed modulo 2^n as

$$(4.6) \quad \left(\begin{array}{cc|c} \mu_{11}2^{\mathbf{a}_{11}} & \mu_{12}2^{\mathbf{a}_{12}} & \mu_{11}\mu_{12}2^{\mathbf{a}_{11}+\mathbf{a}_{12}} \\ \mu_{21}2^{\mathbf{a}_{21}} & \mu_{22}2^{\mathbf{a}_{22}} & \mu_{21}\mu_{22}2^{\mathbf{a}_{21}+\mathbf{a}_{22}} \end{array} \right).$$

We may assume without loss of generality that $\mathbf{a}_{11} \leq \mathbf{a}_{ij}$ for $1 \leq i, j \leq 2$.

If one of the terms on the right hand side is zero, a solution can be written down directly. For example, if $\mu_{12} = 0$ or $2^{\mathbf{a}_{11}+\mathbf{a}_{12}} = 0$, take $(0, \mu_{21}2^{\mathbf{a}_{21}})^T \in \mathbb{Z}_{2^n}^2$. We therefore assume $\mu_{ij} \neq 0$ in the following. A less obvious implication follows from the identity $a_{11}a_{22} + a_{21}a_{12} = 0$ modulo N , which reads in our setting as

$$(4.7) \quad \mu_{11}\mu_{22}2^{\mathbf{a}_{11}+\mathbf{a}_{22}} + \mu_{12}\mu_{21}2^{\mathbf{a}_{12}+\mathbf{a}_{21}} = 0 \pmod{2^n}.$$

If $\mathbf{a}_{11} + \mathbf{a}_{22} \geq n$, or equivalently $\mathbf{a}_{21} + \mathbf{a}_{12} \geq n$, the second entry of the right hand side of (4.6) is zero. Hence, we furthermore add $\mathbf{a}_{11} + \mathbf{a}_{22} < n$ to our list of assumptions, which in particular implies

$$(4.8) \quad \mathbf{a}_{11} + \mathbf{a}_{22} = \mathbf{a}_{21} + \mathbf{a}_{12}.$$

We transform (4.6) into upper triangular form by multiplying the second row with μ_{11} and then subtracting the first row $\mu_{21}2^{\mathbf{a}_{21}-\mathbf{a}_{11}}$ -times from it. Using Equations (4.7) and (4.8), this simplifies to

$$(4.9) \quad \left(\begin{array}{cc|c} \mu_{11}2^{\mathbf{a}_{11}} & \mu_{12}2^{\mathbf{a}_{12}} & \mu_{11}\mu_{12}2^{\mathbf{a}_{11}+\mathbf{a}_{12}} \\ 0 & \det(\mu_{ij})2^{\mathbf{a}_{22}} & (\mu_{22}\mu_{11})(\mu_{21}2^{\mathbf{a}_{21}-\mathbf{a}_{11}} + \mu_{11})2^{\mathbf{a}_{11}+\mathbf{a}_{22}} \end{array} \right).$$

By the minimality of \mathbf{a}_{11} Equations (4.6) and (4.9) have the same set of solutions and the solvability of (4.9) depends only on the existence of a solution for the equation displayed in its second row. We want to simplify this equation further. By the definition of the power of the coefficient matrix there exists an element $\nu \in \mathbb{Z}_{2^n}$, which is invertible or zero, such that $\det(\mu_{ij}) = 2^\tau \nu$. Additionally, we define in the same spirit $\rho \in \mathbb{N}$ to be the minimal number such that $(\mu_{22}\mu_{11})(\mu_{21}2^{\mathbf{a}_{21}-\mathbf{a}_{11}} + \mu_{11}) = 2^\rho \varpi$ for $\varpi \in \mathbb{Z}_{2^n}$, with ϖ invertible or zero. We divide the second row of Equation (4.9) by $2^{\mathbf{a}_{22}}$ and observe that it is solvable if and only if a $d \in \mathbb{Z}_{2^{n-\mathbf{a}_{22}}}$ exists such that

$$(4.10) \quad 2^\tau \nu \cdot d = 2^{\mathbf{a}_{11}+\rho} \varpi \pmod{2^{n-\mathbf{a}_{22}}}.$$

There are three cases which might occur.

First, the right hand side might be zero and the equation is trivially solvable. This is the case if and only if $\varpi = 0$ or $\rho + \mathbf{a}_{11} \geq n - \mathbf{a}_{22}$. One verifies that necessarily $\mathbf{a}_{21} = \mathbf{a}_{11}$ needs to hold.

Second, The right hand side of Equation (4.10) is not zero but $\mathfrak{a}_{11} = \mathfrak{a}_{21}$. Thus, we have $\rho \geq 1$. By Equation (4.7) $\mu_{12}\mu_{21} = -\mu_{11}\mu_{22}$ modulo $2^{n-(\mathfrak{a}_{11}+\mathfrak{a}_{22})}$ and we can write $2^\tau \nu = \det(\mu_{ij}) = 2(\mu_{11}\mu_{22} + \lambda 2^{n-(\mathfrak{a}_{11}+\mathfrak{a}_{22}+1)})$ for a $\lambda \in \mathbb{Z}$. Since the right hand side of Equation (4.10) is non-zero we have $\mathfrak{a}_{11} + \mathfrak{a}_{22} < n - \rho \leq n - 1$ and $(\mu_{11}\mu_{22} + \lambda 2^{n-(\mathfrak{a}_{11}+\mathfrak{a}_{22}+1)})$ is, as the sum of an odd and even integer, invertible modulo $2^{n-\mathfrak{a}_{22}}$. In other words, $\nu \neq 0$, $1 = \tau \leq \rho$ and a solution $d \in \mathbb{Z}_{2^{n-\mathfrak{a}_{22}}}$ exists.

Finally, consider the case where the right hand side of Equation (4.10) is not zero and $\mathfrak{a}_{11} \neq \mathfrak{a}_{21}$. Then $\rho = 0$ and $\varpi \neq 0$. A solution exists if and only if $\tau \leq \mathfrak{a}_{11}$ and $\nu \neq 0$. \square

We study the effect of the order of the group of group-likes of a generalised Taft algebra on the existence of pairs in involution.

Lemma 4.9. *Let $q \in \mathbb{k}$ be a primitive $2^n j$ -th root of unity, with j odd, and $H_q(A)$ a generalised Taft algebra without a pair in involution. Then $n \geq 2$ and $2^n j \neq 4$.*

Proof. Assume $H_q(A)$ to not admit a pair in involution, which implies $n \geq 1$. Let (\mathfrak{a}_{ij}) be the matrix of powers associated to A . In case $n = 1$, it is the zero matrix and by Theorem 4.8 a pair in involution exists. If $2^n j = 4$, note that we have without loss of generality $0 = \mathfrak{a}_{11} \neq \mathfrak{a}_{21} = 1$. The discussion prior to Equation (4.8) shows that $\mathfrak{a}_{11} + \mathfrak{a}_{22} = \mathfrak{a}_{12} + \mathfrak{a}_{21}$ and, therefore, $\mathfrak{a}_{22} = 1$. But $\mathfrak{a}_{21} + \mathfrak{a}_{22} = 2$ implies $\mathfrak{a}_{12}\mathfrak{a}_{22} = 0$ modulo 4, contradicting that A is a parameter matrix. \square

Conversely, we obtain for every natural number $4 \cdot N \geq 8$ an example of a generalised Taft algebra without such a pair.

Lemma 4.10. *Let $N \geq 2$ be a natural number and $q \in \mathbb{k}$ a primitive $4N$ -th root of unity. The generalised Taft algebra $H_q\left(\begin{smallmatrix} 1 & -1 \\ 2 & -2 \end{smallmatrix}\right)$ has no pair in involution.*

Proof. The matrices of powers and coefficients associated to $\left(\begin{smallmatrix} 1 & -1 \\ 2 & -2 \end{smallmatrix}\right)$ are $(\mathfrak{a}_{ij}) = \begin{pmatrix} 0 & 0 \\ 1 & 1 \end{pmatrix}$ and $(\mu_{ij}) = \begin{pmatrix} 1 & -1 \\ 1 & -1 \end{pmatrix}$. Since $\det(\mu_{ij}) = -2$, Theorem 4.8 implies that $H_q\left(\begin{smallmatrix} 1 & -1 \\ 2 & -2 \end{smallmatrix}\right)$ does not admit a pair in involution. \square

Remark 4.11. Suppose $q \in \mathbb{k}$ to be a primitive p -th root of unity for $p > 2$ an odd prime number. For any $s \in \mathbb{Z}_p \setminus \{0\}$, the generalised Taft algebra $H_q\left(\begin{smallmatrix} 1 & 1 \\ s & -s \end{smallmatrix}\right)$ has a pair in involution. In [HK19], Krähmer and the author showed, however, that the modularity condition can only be satisfied if $s \in \{1, p-1\}$.

Requiring the existence of additional structures on generalised Taft algebras might restrict the possible choices of parameter matrices severely. We conclude this section by investigating two such cases and their influence on pairs in involution.

The next theorem, whose proof resembles [KR93, Theorem 3], will help us greatly in that respective. It links the existence of such pairs to their existence for the dual and Drinfeld double.

Theorem 4.12. *Let H be a finite-dimensional Hopf algebra. If any of the Hopf algebras H , H° or $D(H)$ admit a pair in involution, then all do.*

Proof. Let (l, β) be a pair in involution for the finite-dimensional Hopf algebra H . For any $\omega \in H^\circ$ and $h \in H$ we compute

$$\begin{aligned} S^2(\omega)(h) &= \omega(S^2(h)) = \beta(h_{(3)})\beta^{-1}(h_{(1)})\omega(lh_{(2)}l^{-1}) \\ &= \omega_{(1)}(l)\omega_{(3)}(l^{-1}) (\beta^{-1}\omega_{(2)}\beta)(h). \end{aligned}$$

Thus, (β^{-1}, l^{-1}) is a pair in involution for H° . The converse statement follows by the same argument and the fact that H is isomorphic to its bidual.

For any element $\omega \otimes h \in D(H)$ we have

$$\begin{aligned}
(4.11) \quad S^2(\omega \otimes h) &= (S^{-2}(\omega) \otimes 1)(\varepsilon \otimes S^2(h)) \\
&= \omega_{(1)}(l^{-1})\omega_{(3)}(l)\beta^{-1}(h_{(1)})\beta(h_{(3)})(\beta\omega_{(2)}\beta^{-1} \otimes lh_{(2)}l^{-1}) \\
&= \omega_{(1)}(l^{-1})\omega_{(3)}(l)(\omega_{(2)}\beta^{-1} \otimes lh)(\beta \otimes l^{-1}) = (\beta^{-1} \otimes l)(\omega \otimes h)(\beta \otimes l^{-1}).
\end{aligned}$$

In other words, $(\beta^{-1} \otimes l, \varepsilon_{D(H)})$ is a pair in involution for $D(H)$. In fact, it is modular since $\varepsilon_{D(H)}(\beta^{-1} \otimes l) = 1$.

Assume conversely that $\gamma \in \text{Gr}(D(H)^\circ)$ and $c \in \text{Gr}(D(H))$ constitute a pair in involution for $D(H)$. By [Rad12, Proposition 13.2.2], we have $c = \beta \otimes l$ for $\beta \in \text{Gr}(H^\circ)$ and $l \in \text{Gr}(H)$. As $\iota: H \rightarrow D(H)$, $h \mapsto \varepsilon \otimes h$ is an inclusion of Hopf algebras we obtain a character $\tilde{\gamma} := \gamma \circ \iota \in \text{Gr}(H^\circ)$. For any $h \in H$

$$\begin{aligned}
S^2(\iota(h)) &= \tilde{\gamma}(h_{(3)})\tilde{\gamma}^{-1}(h_{(1)})(\beta \otimes l)\iota(h_{(2)})(\beta \otimes l)^{-1} \\
&= \tilde{\gamma}(h_{(5)})\tilde{\gamma}^{-1}(h_{(1)})\beta(h_{(2)})\beta^{-1}(h_{(4)})(\varepsilon \otimes lh_{(3)}l^{-1}) \\
&= (\beta^{-1}\tilde{\gamma})(h_{(3)})(\beta^{-1}\tilde{\gamma})^{-1}(h_{(1)})\iota(h_{(2)}l^{-1}).
\end{aligned}$$

The injectivity of ι implies that $(\beta^{-1}\tilde{\gamma}, l)$ is a pair in involution for H . \square

A finite-dimensional Hopf algebra is called *unimodular* if the distinguished group-like of its dual is equal to its counit.

Lemma 4.13. *Suppose H to be a generalised Taft algebra such that either H or H° is unimodular. Then H has a pair in involution.*

Proof. Assume without loss of generality H° to be unimodular. Let $N = 2^n j \geq 2$, with j odd, q a primitive N -th root of unity and (a_{ij}) a parameter matrix such that $H = H_q(a_{ij})$. By Lemma 4.3 the unimodularity of H° implies $a_{11} + a_{21} = 0$ modulo N . With respect to the matrices of powers and coefficients associated to (a_{ij}) this equation reads as $\mu_{11}2^{a_{11}} + \mu_{21}2^{a_{21}} = 0$ modulo 2^n . Thus, either $\mu_{11} = \mu_{21} = 0$ or $\mathbf{a}_{11} = \mathbf{a}_{21}$. Applying Theorem 4.8 shows that H has a pair in involution. \square

Corollary 4.14. *If the generalised Taft algebra H is quasitriangular, it has a pair in involution.*

Proof. Let $N \geq 2$, q a primitive N -th root of unity and (a_{ij}) a parameter matrix such that $H = H_q(a_{ij})$. Lemma 4.4 asserts that N is even and $a_{11} = a_{21} = \frac{N}{2}$. In particular, $a_{11} + a_{21} = 0$ modulo N . Lemma 4.3 shows that H° is unimodular and therefore H has a pair in involution. \square

Remark 4.15. Drinfeld doubles are quasitriangular and unimodular, see Theorems 10.3.6 and 10.3.12 of [Mon93], respectively. Applying Theorem 4.12 to the Hopf algebras of Lemma 4.10 shows that in general neither unimodularity nor quasitriangularity imply the existence of pairs in involution.

5. ANTI-DRINFELD DOUBLES AND PIVOTALITY

We investigate pairs in involution from a Morita theoretic viewpoint. This leads us to construct two generalised Taft algebras whose underlying algebras are isomorphic. Yet, only one of them admits a pair in involution, implying that such pairs are not a Morita equivalent property. We conclude this article by explaining the connection

between pivotal categories and pairs in involution and commenting on a possible categorical description of such pairs.

Lemma 5.1. *Let $q \in \mathbb{k}$ be a primitive 48-th root of unity. The generalised Taft algebras $H := H_q \left(\begin{smallmatrix} 34 & 26 \\ 4 & 4 \end{smallmatrix} \right)$ and $L := H_q \left(\begin{smallmatrix} 34 & 26 \\ 28 & 4 \end{smallmatrix} \right)$ are isomorphic as algebras but only L admits a pair in involution.*

Proof. One immediately verifies that H and L are generalised Taft algebras. Let $g, x, y \in H$ be the generators of H and $\hat{g}, \hat{x}, \hat{y}$ the generators of L . The defining relations of the algebras H and L are

$$\begin{aligned} x^{\text{ord}(34 \cdot 26)} = x^{\text{ord}(20)} = 0, & \quad y^{\text{ord}(4 \cdot 4)} = y^{\text{ord}(16)} = 0, & \quad xy = q^{34 \cdot 4}yx = q^{40}yx, \\ g^{48} = 1, & \quad gx = q^{26}xg, & \quad gy = q^4yg, \end{aligned}$$

$$\begin{aligned} \hat{x}^{\text{ord}(34 \cdot 26)} = \hat{x}^{\text{ord}(20)} = 0, & \quad \hat{y}^{\text{ord}(28 \cdot 4)} = \hat{y}^{\text{ord}(16)} = 0, & \quad \hat{x}\hat{y} = q^{34 \cdot 4}\hat{y}\hat{x} = q^{40}\hat{y}\hat{x}, \\ \hat{g}^{48} = 1, & \quad \hat{g}\hat{x} = q^{26}\hat{x}\hat{g}, & \quad \hat{g}\hat{y} = q^4\hat{y}\hat{g}. \end{aligned}$$

Therefore, H and L are isomorphic as algebras.

Note that $48 = 3 \cdot 16$. The parameter matrices of H and L modulo 16 are

$$a_{ij}^H = \begin{pmatrix} 34 & 26 \\ 4 & 4 \end{pmatrix} = \begin{pmatrix} 2 & 5 \cdot 2 \\ 4 & 4 \end{pmatrix} \quad \text{and} \quad a_{ij}^L = \begin{pmatrix} 34 & 26 \\ 28 & 4 \end{pmatrix} = \begin{pmatrix} 2 & 5 \cdot 2 \\ 3 \cdot 4 & 4 \end{pmatrix}.$$

In particular, we have $(\mathbf{a}_{ij}^H) = (\mathbf{a}_{ij}^L) = \begin{pmatrix} 1 & 2 \\ 2 & 1 \end{pmatrix}$. The determinants and powers of the matrices of coefficients are $\det(\mu_{ij}^H) = 12$ and $\det(\mu_{ij}^L) = 2$ as well as $\tau^H = 2$ and $\tau^L = 1$, respectively. Theorem 4.8 implies that L has a pair in involution whereas H does not. \square

The next corollary follows readily from the fact that the class of generalised Taft algebras is closed under duality.

Corollary 5.2. *There exist generalised Taft algebras H and L which are isomorphic as coalgebras such that only L has a pair in involution.*

Remark 5.3. The generalised Taft algebras H and L of Lemma 5.1 provide us with examples of Hopf algebras whose anti-Drinfeld doubles $A(H)$ and $A(L)$ are not Morita equivalent in the sense of Lemma 3.5. The Drinfeld and anti-Drinfeld double of L are isomorphic as algebras by Theorem 3.4. The same argument as in the proof of Lemma 3.5 implies that H would admit a pair in involution if $A(H)$ and $A(L) \cong D(L)$ were Morita equivalent in the above sense. This is a contradiction.

We end this article by characterising pairs in involution categorically. Recall that a *pivotal category* is defined as a rigid monoidal category such that a natural monoidal isomorphism between every object and its bidual exists, see [EGNO15, Definition 4.7.7]. This isomorphism can be encoded on the level of Hopf algebras, which is for example discussed in [AAGI⁺14].

Definition 5.4. A *pivotal Hopf algebra* is a pair (H, ρ) of a Hopf algebra H together with a group-like $\rho \in \text{Gr}(H)$, its *pivot*, such that $S^2(h) = \rho h \rho^{-1}$ for all $h \in H$.

The following statement is a consequence of Equation (4.11).

Lemma 5.5. *A finite-dimensional Hopf algebra H has a pair in involution if and only if $D(H)$ is pivotal.*

The relationship between pivotal Hopf algebras and pivotal categories is well-known. For example, the first half of the following result is contained in the proof of [BW99, Proposition 3.6].

Lemma 5.6. *The category $H\text{-Mod}^{\text{fin}}$ of finite-dimensional left modules over a finite-dimensional Hopf algebra is pivotal if and only if H is pivotal.*

Proof. Suppose H to be pivotal with pivot $\rho \in \text{Gr}(H)$. Given a finite-dimensional module (M, \triangleright) over H we define $\omega_M: M \rightarrow M^{\vee\vee}, m \mapsto \text{can}(\rho \triangleright m)$ where $M^{\vee\vee}$ denotes the left bidual of M and ‘can’ the canonical isomorphism of the underlying vector spaces. The definition of the dual module, see [Kas95, III.6, Equation (6.5)], shows that $h \triangleright \text{can}(m) = \text{can}(S^2(h) \triangleright m)$ for every $h \in H$ and $m \in M$. Moreover,

$$\omega_M(h \triangleright m) = \text{can}(\rho h \triangleright m) = S^{-2}(\rho h) \triangleright \text{can}(m) = \rho \rho^{-1} h \rho \triangleright \text{can}(m) = h \triangleright \omega_M(m),$$

for $h \in H$ and $m \in M$. Thus, ω_M is a morphism of modules whose inverse is given by $\omega_M^{-1}: M^{\vee\vee} \rightarrow M, m \mapsto \rho^{-1} \triangleright \text{can}^{-1}(m)$. The naturality of ω is verified by a straightforward computation and since ρ is group-like ω is monoidal.

Conversely, let $H\text{-Mod}^{\text{fin}}$ be pivotal and $\omega: \text{Id} \rightarrow (-)^{\vee\vee}$ a natural monoidal isomorphism. Consider H as a module over itself with multiplication from the left as its action and define $\rho := \text{can}^{-1}(\omega_H(1)) \in H$. Since ω is monoidal ρ is group-like and for all $h \in H$

$$\begin{aligned} S^2(h)\rho &= S^2(h)\text{can}^{-1}(\omega_H(1)) = \text{can}^{-1}(h \triangleright \omega_H(1)) \\ &= \text{can}^{-1}(\omega_H(h)) = \text{can}^{-1}(\omega_H(1 \cdot h)) = \text{can}^{-1}(\omega_H(1))h = \rho h. \end{aligned}$$

This proves (H, ρ) to be a pivotal Hopf algebra. \square

The Yetter–Drinfeld modules over a finite-dimensional Hopf algebra H are equivalent as a monoidal category to the modules over its Drinfeld double. By the two preceding lemmas, the Yetter–Drinfeld modules over H are pivotal if and only if H admits a pair in involution. In conclusion there exists a connection between pairs in involution, anti-Yetter–Drinfeld modules and pivotality. We would be interested in finding a more general characterisation of this interplay using an abstract notion of anti-Yetter–Drinfeld modules as considered for example in [KS19].

PIVOTALITY, TWISTED CENTRES AND THE ANTI-DOUBLE OF A HOPF MONAD

Sebastian Halbig and Tony Zorman

2022

S.H., TECHNISCHE UNIVERSITÄT DRESDEN, INSTITUT FÜR GEOMETRIE, ZELLESCHER WEG 12–14, 01062 DRESDEN
EMAIL ADDRESS: Sebastian.Halbig@tu-dresden.de

T.Z., TECHNISCHE UNIVERSITÄT DRESDEN, INSTITUT FÜR GEOMETRIE, ZELLESCHER WEG 12–14, 01062 DRESDEN
EMAIL ADDRESS: Tony.Zorman@tu-dresden.de

ABSTRACT. Finite-dimensional Hopf algebras admit a correspondence between so-called pairs in involution, one-dimensional anti-Yetter–Drinfeld modules and algebra isomorphisms between the Drinfeld and anti-Drinfeld double. We extend it to general rigid monoidal categories and provide a monadic interpretation under the assumption that certain coends exist. Hereto we construct and study the anti-Drinfeld double of a Hopf monad. As an application the connection with the pivotality of Drinfeld centres and their underlying categories is discussed.

Publication details:

preprint, arXiv:2201.05361 submitted to *Theory and Applications of Categories*

1. INTRODUCTION

The aim of this paper is to study the relationship between the Drinfeld centre of a monoidal category and a ‘twisted’ version of it, which arises in the study of Hopf-cyclic cohomology. Our approach splits into two parts. First, we deploy general categorical tools in order to identify equivalences of the aforementioned categories with ‘invertible’ objects in a twisted centre. Second, we take the monadic point of view and explain which of these equivalences translate into isomorphisms of monads generalising the Drinfeld and anti-Drinfeld double. As a byproduct we exemplify how these monads can be used to detect pivotal structures on a rigid monoidal category.

The Hopf algebraic case. Our goal is best explained by first recalling the interactions between the various objects and categories in the setting of finite-dimensional Hopf algebras. This is covered in greater detail in [Hal21].

A peculiarity of the Hopf-cyclic cohomology, as defined by Connes and Moscovici [CM99], is the lack of ‘canonical’ coefficients. Originally, see [CM00], modular pairs in involution were considered. These consist of a group-like and a character implementing the square of the antipode by their respective adjoint actions. Later, Hajac et.al. obtained a quite general source for coefficients in what they called the category of anti-Yetter–Drinfeld modules, [HKRS04a]. Their name is due to the similarity with Yetter–Drinfeld modules. Like their well-known ‘cousins’, they are simultaneously modules and comodules satisfying a compatibility condition between the action and coaction. In general, they do not form a monoidal category but a module category over the Yetter–Drinfeld modules. This is reflected by the fact that they can be identified with the modules over the anti-Drinfeld double, a comodule algebra over the Drinfeld double. The special role of pairs in involution is captured by the following theorem due to Hajac and Sommerhäuser:

Theorem 1.1 (II.3.4). *For any finite-dimensional Hopf algebra H the following statements are equivalent:*

- (i) *The Hopf algebra H admits a pair in involution.*
- (ii) *There exists an anti-Yetter–Drinfeld module over H whose underlying vector space is the ground field k .*
- (iii) *The Drinfeld and anti-Drinfeld double of H are isomorphic as algebras.*

Furthermore, these pairs are of categorical interest as they give rise to pivotal structures on the Yetter–Drinfeld modules. That is, they provide a natural monoidal isomorphism between each object and its bidual.

Twisted centres and pivotality. We want to reformulate this theorem in a categorical framework with an emphasis on pivotal structures.

First, let us discuss appropriate replacements for the concepts described above. The role of the Hopf algebra is taken by a rigid monoidal category \mathcal{C} . Roughly speaking, that means a category with a suitably associative and unital product in which every object has a left and right dual. Due to the monoid-like nature of \mathcal{C} , we can study its bimodule categories. Of special interest is the regular bimodule, whose actions are given by respectively ‘multiplying’ from the left or right. Its centre $Z(\mathcal{C})$, called the Drinfeld centre of \mathcal{C} , provides us with an analogue of the category of Yetter–Drinfeld modules, see [Kas95, Chapter XIII]. Generalisations of anti-Yetter–Drinfeld modules to what one might call the anti-Drinfeld centre $A(\mathcal{C})$

of \mathcal{C} were considered in the context of topological quantum field theories in [FSS17] and [DSS21] as well as in the categorical description of coefficients of Hopf-cyclic cohomology given in [HKS19]. As in the Hopf algebraic case, $A(\mathcal{C})$ is a module category over $Z(\mathcal{C})$. An adaptation of pairs in involution are, what we will call, quasi-pivotal structures, studied for example in [Shi16]. They consist of an invertible object, which replaces the character, and, instead of a group-like element, a certain natural monoidal isomorphism.

The main observation needed to generalise Theorem 1.1 is that the anti-Drinfeld centre admits a ‘dual’. In Theorem 4.6 this allows us to identify equivalences of $Z(\mathcal{C})$ -modules between $Z(\mathcal{C})$ and $A(\mathcal{C})$ with the so-called \mathcal{C} -invertible objects in $A(\mathcal{C})$. These are objects of $A(\mathcal{C})$ whose image under the canonical forgetful functor to the base category \mathcal{C} is invertible. Subsequently, we prove that these objects correspond to quasi-pivotal structures on \mathcal{C} and obtain the categorical version of Theorem 1.1 as Theorem 4.14.

Theorem 1.2. *Let \mathcal{C} be a rigid monoidal category. The following are equivalent:*

- (i) *The category \mathcal{C} is quasi-pivotal.*
- (ii) *There exists a \mathcal{C} -invertible object in $A(\mathcal{C})$.*
- (iii) *The Drinfeld and anti-Drinfeld centre of \mathcal{C} are equivalent module categories.*

The pivotal structures of the Drinfeld centre $Z(\mathcal{C})$ of a finite tensor category \mathcal{C} were studied by Shimizu in [Shi16]. We contribute to these results with the following observations: the set $\text{Pic } A(\mathcal{C})$ of isomorphism classes of \mathcal{C} -invertible objects in $A(\mathcal{C})$ forms a heap, see Lemma 4.8. That is, it behaves like a group but without a fixed neutral element. Note that this provides a parallel with the aforementioned fact that Hopf-cyclic cohomology has no canonical coefficients. Equipping the set of pivotal structures $\text{Piv } Z(\mathcal{C})$ of $Z(\mathcal{C})$ with the same algebraic structure, we construct a heap morphism $\kappa: \text{Pic } A(\mathcal{C}) \rightarrow \text{Piv } Z(\mathcal{C})$. In general, we cannot expect κ to be injective. Instead, the invertible objects in the centre $Z(\mathcal{C})$ which admit a ‘trivial’ braiding have to be taken into account. The orbits under their action on $\text{Pic } A(\mathcal{C})$ correspond to a quotient heap $\text{Pic } A(\mathcal{C})/\sim$ of $\text{Pic } A(\mathcal{C})$ and indeed, the induced morphism

$$\iota: \text{Pic } A(\mathcal{C})/\sim \rightarrow \text{Piv } Z(\mathcal{C}),$$

is injective, see Theorem 4.23. In many cases, such as \mathcal{C} being a finite tensor category, it is moreover surjective. However, by constructing an explicit counterexample, we show in Theorem 4.38 that this is not true in general. This answers a question raised in [Shi16].

Reconstruction: Comodule monads. To reconcile our results with the initial Hopf algebraic formulation, we provide a monadic interpretation under the assumption that certain coends exist.

The starting point for our considerations is a Hopf monad $H: \mathcal{V} \rightarrow \mathcal{V}$ on a rigid, possibly pivotal, category \mathcal{V} of which we think as a replacement of finite-dimensional vector spaces. Its modules form a rigid monoidal category \mathcal{V}^H . Utilising the centralisers of Day and Street, [DS07], Bruguières and Virelizier described in [BV12] the Drinfeld double $D(H)$ of H . It is obtained through a two-step process. First, the central Hopf monad on \mathcal{V}^H is defined. Then, the double $D(H): \mathcal{V} \rightarrow \mathcal{V}$ arises by applying a variant of Beck’s theorem of distributive laws to it. As in the classical setting, the modules of $D(H)$ are isomorphic as a braided rigid monoidal category to the Drinfeld centre $Z(\mathcal{V}^H)$. By adapting the procedure outlined above for our

purposes, we construct the anti-central monad and derive the anti-Drinfeld double $Q(H): \mathcal{V} \rightarrow \mathcal{V}$ of H from it. It is a comodule monad over $D(H)$ in the sense of [AC12] which implements the ‘dual’ of the anti-centre $Q(\mathcal{V}^H)$ as a module category. Having all ingredients assembled, we show in Theorem 6.25, that certain module equivalences between $Z(\mathcal{V}^H)$ and $Q(\mathcal{V}^H)$ materialise as isomorphisms between their associated monads. Applying our general categorical results to \mathcal{V}^H and combining it with a monadic version of pairs in involution, we obtain in Theorem 6.26 an almost verbatim translation of Theorem 1.1:

Theorem 1.3. *Let H be a Hopf monad on a pivotal category \mathcal{V} that admits a Drinfeld and anti-Drinfeld double. The following are equivalent:*

- (i) *The Hopf monad H admits a pair in involution.*
- (ii) *There exists a module over $Q(H)$ whose underlying object is $1 \in \mathcal{V}$.*
- (iii) *The Drinfeld and anti-Drinfeld double of H are isomorphic as monads.*

An immediate consequence of the above result is the observation that pivotal structures on \mathcal{V}^H equate to isomorphisms between the central and anti-central monads, see Corollary 6.27.

Outline. The article is divided into two parts comprising Sections 2, 3 and 4 as well as Sections 5 and 6. We give a self-contained overview of the necessary categorical tools for our study in Section 2. In Section 3, we recall the concept of heaps. Section 4 starts with a discussion about twisted centres and their Picard heaps, before studying the notion of quasi-pivotality and establishing the rigid monoidal version of the correspondence given in Theorem 1.1. Subsequently, the connection with the pivotal structures on the Drinfeld centre is investigated. Section 5 provides an overview of the theory of Hopf monads and comodule monads. In Section 6 the central and anti-central monad are constructed and from them the Drinfeld and anti-Drinfeld double. By expressing our abstract categorical findings in the monadic language we then obtain Theorem 1.3 and comment on how it can be used to detect pivotal structures.

Acknowledgements. We would like to thank Ilya Shaprio for many fruitful discussions in the early stages of this project and Kenichi Shimizu for helpful remarks concerning symmetric centres and connections to topological quantum field theories.

PART 1:
TWISTED CENTRES AND PIVOTALITY

2. MONOIDAL CATEGORIES, BIMODULE CATEGORIES AND THE CENTRE CONSTRUCTION

Let us recall some background on the theory of monoidal categories needed for our study of pivotal structures in terms of module categories. We assume the readers familiarity with standard concepts of category theory, as given for example in [ML98, Lei14, Rie17]. As a convention, the set of morphisms between two objects $X, Y \in \mathcal{C}$ of a category \mathcal{C} will be written as $\mathcal{C}(X, Y)$. We will denote the composition of two morphisms $g \in \mathcal{C}(X, Y)$ and $f \in \mathcal{C}(W, X)$ by the concatenation $gf := g \circ f \in \mathcal{C}(W, Y)$. Adjunctions play an important role in our investigation. A *right adjoint* of a functor $F: \mathcal{C} \rightarrow \mathcal{D}$ is a functor $U: \mathcal{D} \rightarrow \mathcal{C}$ together with two natural transformations $\eta: \text{Id}_{\mathcal{C}} \rightarrow UF$ and $\epsilon: FU \rightarrow \text{Id}_{\mathcal{D}}$, called the *unit* and *counit* of the adjunction, satisfying for all $X \in \mathcal{C}$ and $Y \in \mathcal{D}$

$$(2.1) \quad F(X) \xrightarrow{F(\eta_X)} FUF(X) \xrightarrow{\epsilon_{F(X)}} F(X) = F(X) \xrightarrow{\text{id}_{F(X)}} F(X),$$

$$(2.2) \quad U(Y) \xrightarrow{\eta_{U(Y)}} UFU(Y) \xrightarrow{U(\epsilon_Y)} U(Y) = U(Y) \xrightarrow{\text{id}_{U(Y)}} U(Y).$$

These conditions determine $U: \mathcal{D} \rightarrow \mathcal{C}$ uniquely up to natural isomorphism. We write $F: \mathcal{C} \rightleftarrows \mathcal{D} : U$ or $F \dashv U$.

To navigate the proverbial ‘sea of jargon’, [BS11a], we provide the reader with a table, inspired by [HPT16, Figure 2], in order to help us outline the main topics we are about to encounter in this section.

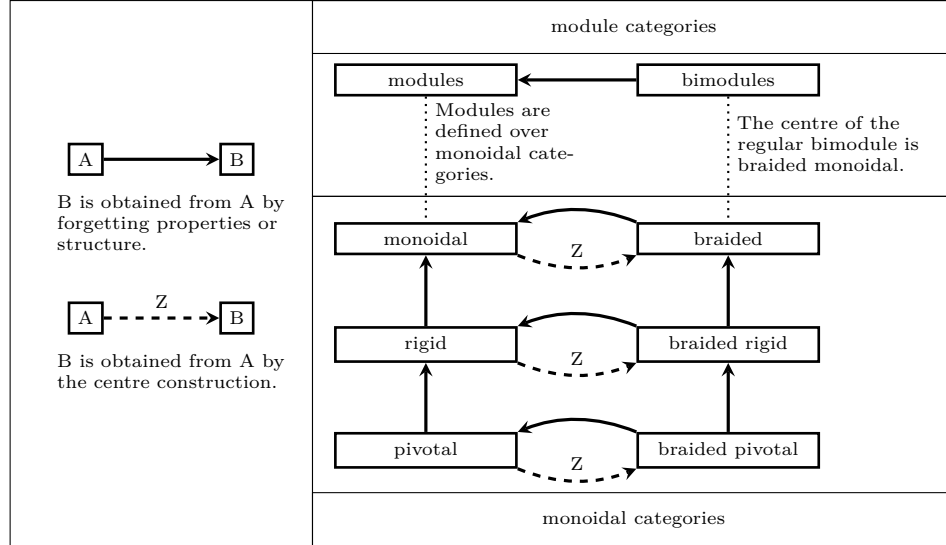

FIGURE 1. Various types of monoidal and module categories, as well as (some) relations between them.

In Subsection 2.1 we work our way down the first column, encountering monoidal, rigid and pivotal categories. This is based on [EGNO15, Chapter 2]. The concept of braided monoidal categories, responsible for the second column, is discussed in Subsection 2.2. See [EGNO15, Chapter 8] for a reference. Our approach to module categories, see Subsection 2.3, is derived from [EGNO15, Chapter 7]. We pay special attention to the (Drinfeld) centre construction, responsible for the arrows labelled with a ‘Z’, in Figure 1.

2.1. From monoidal to pivotal categories. Monoidal categories were introduced independently by Mac Lane, [ML63], and Bénabou, [Bén63], under the name ‘categories with multiplication’.⁷ The prime examples we draw our inspiration from are finite-dimensional modules over Hopf algebras or, more generally, finite tensor categories, see [EGNO15, Chapters 5 and 6].

2.1.1. *Monoidal categories, their functors and natural transformations.*

Definition 2.1. A *strict monoidal category* is a triple $(\mathcal{C}, \otimes, 1)$ comprising a category \mathcal{C} , a bifunctor $\otimes: \mathcal{C} \times \mathcal{C} \rightarrow \mathcal{C}$, called the *tensor product*, and an object $1 \in \mathcal{C}$, the *unit*, satisfying associativity and unitality in the sense that

$$(2.3) \quad (- \otimes -) \otimes - = - \otimes (- \otimes -) \quad \text{and} \quad 1 \otimes - = \text{Id}_{\mathcal{C}} = - \otimes 1.$$

Many natural examples of monoidal categories, such as the category of vector spaces, are not strict. That is, the associativity and unitality of the tensor product only hold up to (suitably coherent) natural isomorphisms. However, we can compensate this by *Mac Lane’s strictification theorem*. It states that any monoidal category is, in a ‘structure preserving manner’, equivalent to a strict one. A proof is given for example in [EGNO15, Theorem 2.8.5]. For this reason, and to keep our notation concise, we shall omit the prefix ‘strict’ from now on.

The next definition slightly extends the scope of [EGNO15] but is standard in the literature, see for example [AM10, Chapter 3].

Definition 2.2. An *oplax monoidal functor* between monoidal categories $(\mathcal{C}, \otimes, 1)$ and $(\mathcal{C}', \otimes', 1')$ is a functor $F: \mathcal{C} \rightarrow \mathcal{C}'$ together with a natural transformation

$$\Delta_{X,Y}: F(X \otimes Y) \rightarrow F(X) \otimes' F(Y), \quad \text{for all } X, Y \in \mathcal{C},$$

and a morphism $\varepsilon: F(1) \rightarrow 1'$ satisfying for all $W, X, Y \in \mathcal{C}$

$$(2.4) \quad (\text{id}_{F(W)} \otimes' \Delta_{X,Y}) \Delta_{W, X \otimes Y} = (\Delta_{W,X} \otimes' \text{id}_{F(Y)}) \Delta_{W \otimes X, Y},$$

$$(2.5) \quad (\varepsilon \otimes' \text{id}_{F(1)}) \Delta_{1,1} = F(\text{id}_1) = (\text{id}_{F(1)} \otimes' \varepsilon) \Delta_{1,1}.$$

If the *coherence morphisms*, Δ and ε , are isomorphisms or identities, we call F (*strong*) *monoidal* or *strict monoidal*, respectively.

We think of an oplax monoidal functor (F, Δ, ε) as a generalisation of a coalgebra. To emphasise this point of view, we refer to Δ and ε as the *comultiplication* and *counit* of F . The dual concept is that of a *lax monoidal functor*, which resembles the notion of an algebra.

Assume $F: \mathcal{C} \rightarrow \mathcal{D}$ to be strong monoidal and an equivalence of categories. Its quasi-inverse $G: \mathcal{D} \rightarrow \mathcal{C}$ can be turned into a monoidal functor such that the natural isomorphisms $FG \rightarrow \text{Id}_{\mathcal{D}}$ and $GF \rightarrow \text{Id}_{\mathcal{C}}$ are compatible with the monoidal structure in a sense we will explain in the next definition. This justifies calling F a *monoidal equivalence*.

Definition 2.3. An *oplax monoidal natural transformation* between oplax monoidal functors $F, G: \mathcal{C} \rightarrow \mathcal{C}'$ is a natural transformation $\rho: F \rightarrow G$ such that for all $X, Y \in \mathcal{C}$

$$(2.6) \quad \Delta_{X,Y}^{(G)} \rho_{X \otimes Y} = (\rho_X \otimes' \rho_Y) \Delta_{X,Y}^{(F)} \quad \text{and} \quad \varepsilon^{(G)} \rho_1 = \varepsilon^{(F)}.$$

⁷Parts of the historical development of the study of monoidal categories are sketched in [Str12] and, to a lesser extend, in [BS11a].

If ρ is additionally a natural isomorphism, we call it an *oplax monoidal natural isomorphism*.

In case we want to emphasise that the underlying functors of an oplax monoidal natural transformation $\rho: F \rightarrow G$ are strong or strict monoidal, we replace the prefix ‘oplax’ with either ‘strong’ or ‘strict’.

Adjunctions between monoidal categories are a broad topic with many facets, see [AM10, Chapter 3]. For our purposes, we can restrict ourselves to the following situation.

Definition 2.4. We call an adjunction $F: \mathcal{C} \rightleftarrows \mathcal{D} : U$ between monoidal categories \mathcal{C} and \mathcal{D} *oplax monoidal* if F and U are oplax monoidal functors and the unit and counit of the adjunction are oplax monoidal natural transformations. If F and U are moreover strong monoidal, we call $F: \mathcal{C} \rightleftarrows \mathcal{D} : U$ a (*strong*) *monoidal adjunction*.

An efficient means for computations in strict monoidal categories are *string diagrams*. They consist of strings labelled with objects and vertices between the strings labelled with morphisms. If two string diagrams can be transformed into each other, the morphisms that they represent are equal. A more detailed description is given in [Sel11]. Our convention is to read diagrams from top to bottom and left to right. Taking tensor products is depicted by gluing diagrams together horizontally; composition equates to gluing vertically. Identity morphisms are given by unlabelled vertices. The unit object is represented by the empty edge.

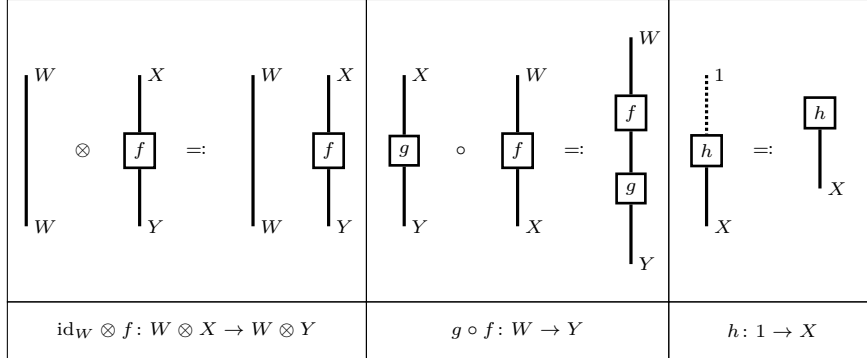

2.1.2. Rigidity and pivotality. Rigidity in the context of monoidal categories refers to a concept of duality similar to that of finite-dimensional vector spaces. Importantly, notions like dual bases and evaluations have their analogues in this setting. If, moreover, there exists an identification between objects and their biduals that is compatible with the tensor product, the category is called pivotal. The more refined notion of spherical categories is not discussed here. For a treatment in the context of Hopf algebras we refer to the articles [BW99] and [AAGI⁺14]. Examples of duality inspired by topology are discussed in [DP80].

Definition 2.5. A *left dual* of an object $X \in \mathcal{C}$ in a monoidal category \mathcal{C} is a triple $(X^\vee, \text{ev}_X^l, \text{coev}_X^l)$ comprising an object X^\vee and two morphisms

$$(2.7) \quad \text{ev}_X^l: X^\vee \otimes X \rightarrow 1 \quad \text{and} \quad \text{coev}_X^l: 1 \rightarrow X \otimes X^\vee,$$

called the left *evaluation* and *coevaluation* of X , such that the *snake identities*

$$(2.8a) \quad \text{id}_X = (\text{id}_X \otimes \text{ev}_X^l)(\text{coev}_X^l \otimes \text{id}_X) \quad \text{and}$$

$$(2.8b) \quad \text{id}_{X^\vee} = (\text{ev}_X^l \otimes \text{id}_{X^\vee})(\text{id}_{X^\vee} \otimes \text{coev}_X^l)$$

hold. A *right dual* of X is a triple $({}^\vee X, \text{ev}_X^r, \text{coev}_X^r)$ consisting of an object ${}^\vee X$ and a right evaluation and coevaluation,

$$(2.9) \quad \text{ev}_X^r: X \otimes {}^\vee X \rightarrow 1 \quad \text{and} \quad \text{coev}_X^r: 1 \rightarrow {}^\vee X \otimes X,$$

subject to analogous identities.

We call \mathcal{C} a *rigid category* if every object has a left and right dual.

Left and right duals are unique up to unique isomorphism. We fix a choice of duals for every object in a rigid category \mathcal{C} and speak of *the* left or right dual in the following. Graphically, we represent evaluations and coevaluations by semicircles, possibly decorated with arrows if we want to emphasise whether we consider their left or right version.

$\text{ev}_X^l: X^\vee \otimes X \rightarrow 1$	$\text{coev}_X^l: 1 \rightarrow X \otimes X^\vee$	$\text{ev}_X^r: X \otimes {}^\vee X \rightarrow 1$	$\text{coev}_X^r: 1 \rightarrow {}^\vee X \otimes X$

Definition 2.6. An object $X \in \mathcal{C}$ in a rigid category \mathcal{C} is called *invertible* if its (left) evaluation and coevaluation are isomorphisms.

It is an illustrative exercise to show that the right evaluations and coevaluations of an invertible objects must be isomorphisms as well. Tensor products and duals of invertible objects are invertible too. Hence, we can consider the full and rigid subcategory $\text{Inv } \mathcal{C} \subseteq \mathcal{C}$ of invertible objects of \mathcal{C} .

Definition 2.7 ([May01, Definition 2.10]). The *Picard group* $\text{Pic } \mathcal{C}$ of a rigid category \mathcal{C} is the group of isomorphism classes of invertible objects in \mathcal{C} . Its multiplication is induced by the tensor product of \mathcal{C} , i.e.

$$(2.10) \quad [\alpha] \cdot [\beta] := [\alpha \otimes \beta], \quad \text{for } \alpha, \beta \in \text{Inv}(\mathcal{C}).$$

The unit of $\text{Pic } \mathcal{C}$ is $[1]$ and for any $\alpha \in \text{Inv}(\mathcal{C})$ we have $[\alpha]^{-1} = [\alpha^\vee]$.

The next theorem will play a central role in our studies. To formulate it, we introduce for any $X \in \mathcal{C}$ and $n \in \mathbb{Z}$ the shorthand-notation

$$(2.11) \quad (X)^n := \begin{cases} \text{The } n\text{-fold left dual of } X & \text{if } n > 0, \\ X & \text{if } n = 0, \\ \text{The } n\text{-fold right dual of } X & \text{if } n < 0. \end{cases}$$

Theorem 2.8. For every object $X \in \mathcal{C}$ in a rigid category \mathcal{C} we obtain two chains of adjoint endofunctors of \mathcal{C} :

$$(2.12) \quad \dots \dashv (- \otimes (X)^{-1}) \dashv (- \otimes X) \dashv (- \otimes (X)^1) \dashv \dots \quad \text{and}$$

$$(2.13) \quad \dots \dashv ((X)^1 \otimes -) \dashv (X \otimes -) \dashv ((X)^{-1} \otimes -) \dashv \dots$$

Furthermore, $- \otimes X$ and $X \otimes -$ are equivalences of categories if and only if X is invertible.

Proof. The existence of the stated chains of adjunctions follows from [EGNO15, Proposition 2.10.8]. For example, for any $Y \in \mathcal{C}$ the unit and counit of the adjunction between $- \otimes X$ and $- \otimes X^\vee$ are given by

$$Y \xrightarrow{\text{id}_Y \otimes \text{coev}_X^l} Y \otimes X \otimes X^\vee \quad \text{and} \quad Y \otimes X^\vee \otimes X \xrightarrow{\text{id}_Y \otimes \text{ev}_X^l} Y.$$

Then, Equations (2.1) and (2.2) translate to the snake identities (2.8a) and (2.8b). From this point of view, it becomes clear that tensoring (from the left or the right) with an invertible object establishes an equivalence of categories. Conversely, suppose that $X \in \mathcal{C}$ is such that $F := - \otimes X$ is an equivalence of categories. The functor F and its quasi-inverse U are part of an adjunction with invertible unit $\eta: \text{Id}_{\mathcal{C}} \rightarrow UF$ and counit $\epsilon: FU \rightarrow \text{Id}_{\mathcal{D}}$, see for example [Rie17, Proposition 4.4.5]. By [Rie17, Proposition 4.4.1], there exists a natural isomorphism $\theta: U \rightarrow - \otimes X^\vee$ which commutes with the respective counits and units. Applied to the monoidal unit $1 \in \mathcal{C}$, we obtain

$$\text{coev}_X^l = \theta_X \eta_1 \quad \text{and} \quad \text{ev}_X^l(\theta_1 \otimes \text{id}_X) = \epsilon_1.$$

It follows that X is invertible. An analogous argument shows that $X \otimes -$ being an equivalence of categories entails X being invertible. \square

Next, we want to turn taking duals into a functor. Let $f: X \rightarrow Y$ be a morphism between two objects $X, Y \in \mathcal{C}$ in a rigid category \mathcal{C} . Its *left dual* $f^\vee: Y^\vee \rightarrow X^\vee$ is defined in terms of the following diagram:

(2.14)

$$f^\vee := (\text{ev}_Y^l \otimes \text{id}_{X^\vee})(\text{id}_{Y^\vee} \otimes f \otimes \text{id}_{X^\vee})(\text{id}_{Y^\vee} \otimes \text{coev}_X^l): Y^\vee \rightarrow X^\vee.$$

This assignment is contravariantly functorial. Since $(X \otimes Y)^\vee \cong Y^\vee \otimes X^\vee$, taking duals is also compatible with the *opposite tensor product*. In conclusion, we have a monoidal functor, the *left dualising functor*,

$$(2.15) \quad (-)^\vee: \mathcal{C} \rightarrow \mathcal{C}^{\text{op}, \otimes\text{-op}},$$

mapping objects and morphisms to their left duals. Its coherence morphisms are given by the isomorphisms induced by the uniqueness of duals. Similarly, we have a *right dualising functor* ${}^\vee(-): \mathcal{C} \rightarrow \mathcal{C}^{\text{op}, \otimes\text{-op}}$. To simplify computations, we want to ‘strictify’ both of these.

Definition 2.9. Let \mathcal{C} be a rigid monoidal category with fixed left and right duals for every object. It is called *strict rigid*⁸ if the induced dualisation functors $(-)^\vee, {}^\vee(-): \mathcal{C} \rightarrow \mathcal{C}^{\text{op}, \otimes\text{-op}}$ are strict and

$$(2.16) \quad ({}^\vee(-))^\vee = \text{Id}_{\mathcal{C}} = {}^\vee((-)^\vee).$$

⁸The notion of ‘strict rigidity’ is not prevalent in the literature and does not appear in [EGNO15]. However, hints towards it can be found for example in [Sch01, Section 5].

Our next theorem, a slight variation of [NS07, Theorem 2.2], shows that every rigid category admits a *rigid strictification*, i.e. a monoidally equivalent strict rigid category. The hinted at compatibility between the respective left and right duality functors is an immediate consequence of the fact that for any strong monoidal functor $F: \mathcal{C} \rightarrow \mathcal{D}$ between rigid categories there are natural monoidal isomorphisms

$$(2.17) \quad \varphi_X: F(X^\vee) \rightarrow (F(X))^\vee, \quad \vartheta_X: F({}^\vee X) \rightarrow {}^\vee(F(X)), \quad \text{for all } X \in \mathcal{C}.$$

Theorem 2.10. *Every rigid category admits a rigid strictification.*

Proof. Taking a rigid and strict monoidal category \mathcal{C} as our input, we build a monoidally equivalent strict rigid category \mathcal{D} . The objects of \mathcal{D} are (possibly empty) finite sequences $(X_1^{n_1}, \dots, X_i^{n_i})$ of objects $X_1, \dots, X_i \in \mathcal{C}$ adorned with integers $n_1, \dots, n_i \in \mathbb{Z}$. To define its morphisms, recall the notation of Equation (2.11) and set:

$$\mathcal{D}((X_1^{n_1}, \dots, X_i^{n_i}), (Y_1^{m_1}, \dots, Y_j^{m_j})) := \mathcal{C}((X_1)^{n_1} \otimes \dots \otimes (X_i)^{n_i}, (Y_1)^{m_1} \otimes \dots \otimes (Y_j)^{m_j}).$$

The category \mathcal{D} is strict monoidal when equipped with the concatenation of sequences as tensor product and the empty sequence as unit. By construction, there exists a strict monoidal equivalence of categories $F: \mathcal{D} \rightarrow \mathcal{C}$, which maps any object $(X_1^{n_1}, \dots, X_i^{n_i}) \in \mathcal{D}$ to $(X_1)^{n_1} \otimes \dots \otimes (X_i)^{n_i} \in \mathcal{C}$ and every morphism to itself⁹. Now fix an object $X := (X_1^{n_1}, \dots, X_i^{n_i}) \in \mathcal{D}$. We define its left dual to be given by $X^\vee := (X_i^{n_i+1}, \dots, X_1^{n_1+1})$ with evaluation and coevaluation morphisms as shown in the following diagram

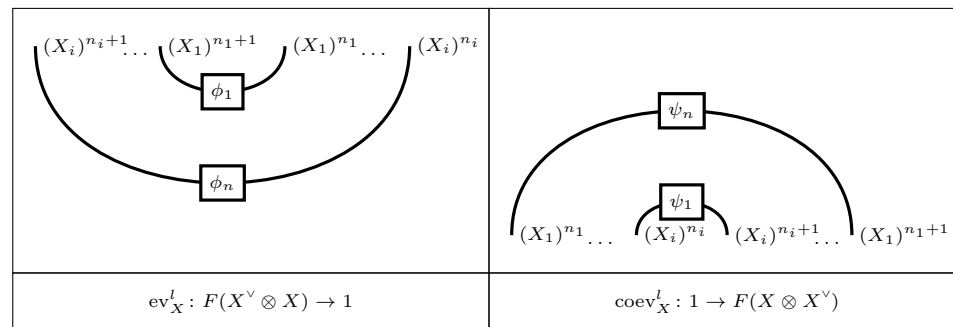

where for all $1 \leq k \leq i$ we set

$$\phi_k := \begin{cases} ev_{(X_k)^{n_k}}^l & \text{if } n_k \geq 0, \\ ev_{(X_k)^{n_k+1}}^r & \text{if } n_k < 0, \end{cases} \quad \text{and} \quad \psi_k := \begin{cases} coev_{(X_k)^{n_k}}^l & \text{if } n_k \geq 0, \\ coev_{(X_k)^{n_k+1}}^r & \text{if } n_k < 0. \end{cases}$$

We define the right dual of X to be ${}^\vee X := (X_i^{n_i-1}, \dots, X_1^{n_1-1})$ with evaluation and coevaluation similar to the above construction. It follows that \mathcal{D} is strict rigid. \square

Many applications require that the objects of a rigid category are isomorphic to their biduals in a way which is compatible with the monoidal structure. One of our aims is to gain a representation theoretic approach to detecting such a property.

Definition 2.11. A *pivotal category* is a rigid category \mathcal{C} together with a fixed monoidal natural isomorphism

$$(2.18) \quad \rho: \text{Id}_{\mathcal{C}} \rightarrow (-)^{\vee\vee},$$

⁹In the definition of $F: \mathcal{D} \rightarrow \mathcal{C}$ we regard the unit of \mathcal{C} as the empty tensor product.

which is referred to as a *pivotal structure* of \mathcal{C} .

Rigid categories do not have to admit a pivotal structure and, if they do, it need not be unique. Examples coming from Hopf algebra theory are given in [KR93] and [HK19, Hal21]. However, Shimizu showed that every rigid category admits a universal pivotal category, called its *pivotal cover*, see [Shi15].

2.2. Braided categories. Braidings are natural transformations relating the tensor product to its opposite. They were introduced by Joyal and Street in [JS93], building on the notion of symmetries studied amongst others in [ML63, EK66].

Definition 2.12. A *braiding* on a monoidal category \mathcal{C} is a natural isomorphism

$$\sigma_{X,Y}: X \otimes Y \rightarrow Y \otimes X, \quad \text{for all } X, Y \in \mathcal{C},$$

which satisfies *the hexagon axioms*¹⁰. That is, for all $W, X, Y \in \mathcal{C}$

$$(2.19) \quad \sigma_{W, X \otimes Y} = (\text{id}_X \otimes \sigma_{W,Y})(\sigma_{W,X} \otimes \text{id}_Y) \quad \text{and}$$

$$(2.20) \quad \sigma_{W \otimes X, Y} = (\sigma_{W,Y} \otimes \text{id}_X)(\text{id}_W \otimes \sigma_{X,Y}).$$

The pair (\mathcal{C}, σ) is referred to as *braided monoidal category*.

Remark 2.13. Often, we will make use of the fact that the braiding of any object $X \in \mathcal{C}$ with the unit $1 \in \mathcal{C}$ of a braided category (\mathcal{C}, σ) is trivial. This is a consequence of the hexagon identities as the following considerations exemplify. First, we compute

$$\sigma_{X,1} = \sigma_{X,1 \otimes 1} = (\text{id}_1 \otimes \sigma_{X,1})(\sigma_{X,1} \otimes \text{id}_1) = \sigma_{X,1} \sigma_{X,1}.$$

Then, we compose both sides with $\sigma_{X,1}^{-1}$ and observe that $\sigma_{X,1} = \text{id}_X$. Similarly, we obtain $\sigma_{1,X} = \text{id}_X$.

Braidings are depicted in the graphical calculus by crossings of strings subject to Reidemeister-esque identities, see [Sel11]. In the following figure, we show from left to right a braiding, its inverse, the hexagon identity (2.19) and the naturality of the braiding in its first argument.

$\sigma_{X,Y}$	$\sigma_{X,Y}^{-1}$	$(\text{id}_X \otimes \sigma_{W,Y})(\sigma_{W,X} \otimes \text{id}_Y) = \sigma_{W, X \otimes Y}$	$\sigma_{X,Y}(f \otimes \text{id}_Y) = (\text{id}_Y \otimes f)\sigma_{W,X}$

2.3. Bimodule categories and the centre construction. Just as monoids can act on sets, monoidal categories can act on categories. Thinking representation theoretically therefore advocates studying monoidal categories through their modules. In parallel with our treatment of monoidal categories, we will focus solely on their ‘strict modules’. Again, a more general theory is possible by weakening the associativity and unitality of the action.

¹⁰The name ‘hexagon axioms’ is due to the fact, that in the non-strict setting, the defining Equations (2.19), (2.20) can be organised as a commuting, hexagon-shaped diagrams; see [JS93].

2.3.1. Left, right and bimodule categories.

Definition 2.14. A *strict left module (category)* over a monoidal category \mathcal{C} is a pair $(\mathcal{M}, \triangleright)$ comprising a category \mathcal{M} and an *action* of \mathcal{C} on \mathcal{M} implemented by a functor $\triangleright : \mathcal{C} \times \mathcal{M} \rightarrow \mathcal{M}$ such that

$$(2.21) \quad (- \otimes -) \triangleright - = - \triangleright (- \triangleright -) \quad \text{and} \quad 1 \triangleright - = \text{Id}_{\mathcal{M}}.$$

To keep our notation concise, we will simply speak of modules, instead of strict module categories, over a monoidal category.

For a functor between modules to be structure preserving, it has to satisfy a variant of equivariance which is encoded by a natural isomorphism.

Definition 2.15. Let \mathcal{M} and \mathcal{N} be left modules over a monoidal category \mathcal{C} . A *functor of left modules* is a functor $F : \mathcal{M} \rightarrow \mathcal{N}$ together with a natural isomorphism

$$\delta_{X,M} : F(X \triangleright M) \rightarrow X \triangleright F(M), \quad \text{for all } X \in \mathcal{C} \text{ and } M \in \mathcal{M}$$

such that

$$(2.22) \quad \delta_{X \otimes Y, M} = (\text{id}_X \triangleright \delta_{Y, M}) \delta_{X, Y \triangleright M}, \quad \text{for all } X, Y \in \mathcal{C} \text{ and } M \in \mathcal{M},$$

$$(2.23) \quad \text{id}_M = \delta_{1, M}, \quad \text{for all } M \in \mathcal{M}.$$

We call (F, δ) *strict* if δ is given by the identity.

With respect to the analogy between oplax monoidal functors and coalgebras, module functors play the role of (strong) comodules over the identity functor. We will encounter the more general concept of comodule functors in Sections 5 and 6.

An *equivalence of module categories* is a functor of module categories $F : \mathcal{M} \rightarrow \mathcal{N}$ that is an equivalence. As with monoidal categories, it admits a quasi-inverse functor of module categories $G : \mathcal{N} \rightarrow \mathcal{M}$ and the natural isomorphisms $FG \rightarrow \text{Id}_{\mathcal{N}}$ and $GF \rightarrow \text{Id}_{\mathcal{M}}$ are compatible with the respective ‘coactions’ in a way explained in the next definition.

Definition 2.16. Let $F, G : \mathcal{M} \rightarrow \mathcal{N}$ be two functors of left modules over a monoidal category \mathcal{C} . A *morphism of left module functors* is a natural transformation $\phi : F \rightarrow G$ satisfying for all $X \in \mathcal{C}$ and $M \in \mathcal{M}$

$$(2.24) \quad (\text{id}_X \triangleright \phi_M) \delta_{X, M}^{(F)} = \delta_{X, M}^{(G)} \phi_{X \triangleright M}.$$

Module adjunctions will be a corner stone of our investigation. They are defined as adjunctions $F : \mathcal{M} \rightleftarrows \mathcal{N} : G$ of module functors between module categories whose unit and counit are module natural transformations.

A theory of *right modules* can be formulated in a similar fashion. More precisely, right modules over a monoidal category \mathcal{C} can be identified with left modules over $\mathcal{C}^{\otimes\text{-op}}$. If we assume some additional conditions on \mathcal{C} , we could define its bimodules as left modules over an ‘enveloping category’ \mathcal{C}^e of \mathcal{C} , see for example [EGNO15, Exercise 7.4.3]. For our purposes, however, it will be more beneficial to define them explicitly in terms of categories with compatible left and right actions.

Definition 2.17. A *(strict) bimodule* $(\mathcal{M}, \triangleright, \triangleleft)$ over a monoidal category \mathcal{C} is a category \mathcal{M} which is simultaneously a left and right module and

$$(2.25) \quad (- \triangleright -) \triangleleft - = - \triangleright (- \triangleleft -).$$

Example 2.18. The prime example of a bimodule over a monoidal category \mathcal{C} is the *regular bimodule* ${}_{\text{Id}_{\mathcal{C}}}\mathcal{C}{}_{\text{Id}_{\mathcal{C}}}$. As a category, it is simply \mathcal{C} and the left and right actions are given by tensoring from the left and right, respectively.

Remark 2.19. If \mathcal{C} is for example a tensor category, its bimodules form a monoidal 2-category, see [Gre10].

Since we will not work with bimodule functors and their natural transformations, we will not state their precise definitions. Rather, we remark that they equate to (strong) ‘bicomodules’ over the identity functor.

2.3.2. *The Drinfeld centre of a monoidal category.* The centre construction can be used to obtain a braided category from a monoidal one. We work in a slightly more general setup than [EGNO15, Chapter 7] and define centres for bimodule categories. See [GNN09, BV12, FSS17, HKS19, Kow20] for similar considerations.

Definition 2.20. Let \mathcal{M} be a bimodule over a monoidal category \mathcal{C} and $M \in \mathcal{M}$ an object. A *half-braiding* on M is a natural isomorphism

$$\sigma_{M,X}: M \triangleleft X \rightarrow X \triangleright M, \quad \text{for all } X \in \mathcal{C},$$

satisfying for all $X, Y \in \mathcal{C}$ the hexagon axiom

$$(2.26) \quad \sigma_{M,X \otimes Y} = (\text{id}_X \triangleright \sigma_{M,Y})(\sigma_{M,X} \triangleleft \text{id}_Y).$$

Let $\sigma_{M,-}: M \triangleleft - \rightarrow - \triangleright M$ be a half-braiding on an object $M \in \mathcal{M}$. The same arguments as in Remark 2.13 show that $\sigma_{M,1} = \text{id}_M$ for all $M \in \mathcal{M}$.

Thinking of objects plus half-braidings as ‘central elements’, one can try to mimic the centre construction from representation theory. This leads to the following definition.

Definition 2.21. The centre of a bimodule \mathcal{M} over a monoidal category \mathcal{C} is the category $\mathbf{Z}(\mathcal{M})$. It has as objects pairs $(M, \sigma_{M,-})$ comprising an object $M \in \mathcal{M}$ together with a half-braiding $\sigma_{M,-}$ on M . The set of morphisms between two objects $(M, \sigma_{M,-}), (N, \sigma_{N,-}) \in \mathbf{Z}(\mathcal{M})$, consists of those morphisms $f \in \mathcal{M}(M, N)$ which commute with the half-braidings. That is,

$$(2.27) \quad (\text{id}_X \triangleright f)\sigma_{M,X} = \sigma_{N,X}(f \triangleleft \text{id}_X), \quad \text{for all } X \in \mathcal{C}.$$

There is a canonical forgetful functor $U^{(M)}: \mathbf{Z}(\mathcal{M}) \rightarrow \mathcal{M}$. Unlike classical representation theory where the centre of a bimodule is a subset, $U^{(M)}$ need not be injective on objects in general.

Example 2.22. The centre $\mathbf{Z}(\mathcal{C})$ of the regular bimodule of a monoidal category \mathcal{C} is called the *Drinfeld centre* or simply centre of \mathcal{C} . It is braided monoidal. The tensor product is defined by $(M, \sigma_{M,-}) \otimes (N, \sigma_{N,-}) := (M \otimes N, \sigma_{M \otimes N,-})$ with

$$\sigma_{M \otimes N, X} := (\sigma_{M,X} \otimes \text{id}_N)(\text{id}_M \otimes \sigma_{N,X}), \quad \text{for all } X \in \mathcal{C}.$$

Its braiding is given by the respective half-braidings. The hexagon axioms follow from Equation (2.26) and the definition of the tensor product of $\mathbf{Z}(\mathcal{C})$.

Our next theorem uses the shorthand notation for iterated duals given in Equation (2.11).

There are two peculiarities we want to point out. First, our definition does, intentionally, not exclude the empty set from being a heap. Second, due to a slightly different setup, an additional ‘middle’ associativity axiom is required in [HL17]. However, as noted in [Brz20, Lemma 2.3], it is implied by the ‘outer’ associativity and the Mal’cev identities.

Definition 3.2. A map $f: G \rightarrow H$ between heaps is a *morphism of heaps* if

$$(3.3) \quad f(\langle g, h, i \rangle) = \langle f(g), f(h), f(i) \rangle, \quad \text{for all } g, h, i \in G.$$

The next lemma can be shown by mimicking the proof of its group theoretical version.

Lemma 3.3. *A morphism of heaps $f: G \rightarrow H$ is an isomorphism if and only if it is bijective.*

By forgetting its unit, any group defines a heap. Conversely, any non-empty heap can be turned into a group by choosing a fixed element to act as unit, see [Cer43].

Lemma 3.4. *Every group (G, \cdot, e) is a heap via*

$$\langle -, -, - \rangle: G \times G \times G \rightarrow G, \quad \langle g, h, i \rangle := g \cdot h^{-1} \cdot i.$$

A morphism of groups becomes a morphism of the induced heaps.

Lemma 3.5. *A non-empty heap H with a fixed element $e \in H$ can be considered as a group with unit e via the multiplication*

$$- \cdot_e -: H \times H \rightarrow H, \quad g \cdot_e h := \langle g, e, h \rangle.$$

With respect to this multiplication, the inverse of an element $g \in H$ is given by $g^{-1} := \langle e, g, e \rangle$. A morphism of heaps is a morphism of the induced groups, provided it maps the fixed element of its source to the fixed element of its target.

We end this section by discussing an example of heaps which will play a prominent role in our investigation.

Example 3.6. Let $F, G: \mathcal{C} \rightarrow \mathcal{C}$ be two oplax monoidal endofunctors. The set

$$\text{Iso}_{\otimes}(F, G) := \{\text{oplax monoidal natural isomorphisms from } F \text{ to } G\}$$

bears a heap structure with multiplication

$$(3.4) \quad \langle -, -, - \rangle: \text{Iso}_{\otimes}(F, G)^3 \rightarrow \text{Iso}_{\otimes}(F, G), \quad \langle \phi, \psi, \xi \rangle = \phi\psi^{-1}\xi.$$

4. PIVOTAL STRUCTURES AND TWISTED CENTRES

In this section, we study the relations between pairs in involution, anti-Yetter-Drinfeld modules and isomorphisms between the Drinfeld and anti-Drinfeld double from a categorical point of view. Our approach is representation theoretic in nature.

We consider variants of the regular bimodule of a rigid category \mathcal{C} with either the left or right action twisted by a strict monoidal endofunctor. Their centres are canonically modules over the Drinfeld centre. These *twisted centres* inherit a notion of duality which follows in close parallel to that of $Z(\mathcal{C})$. Functors of $Z(\mathcal{C})$ -modules between the Drinfeld and a twisted centre are determined by their value on the unit object. A consequence of the above sketched duality is that module equivalences correspond to objects in the twisted centre, which behave as if they were invertible. We gather these objects into the Picard heap of the twisted centre. If we twist with

the left biduality functor, we obtain a generalised version of the anti-Yetter–Drinfeld modules, see [HKS19]. Its Picard heap has an alternative interpretation as quasi-pivotal structures; appropriate analogues of pairs in involution. This observation leads us to the desired categorical version of the Hajac–Sommerhäuser theorem, given in Theorem 4.14.

In [Shi16], Shimizu observed that quasi-pivotality of \mathcal{C} induces pivotality of $Z(\mathcal{C})$. We recall his proof from the perspective of twisted centres and investigate how this construction is related to the so-called symmetric centre of \mathcal{C} . This leads to an injective heap morphism from a quotient of the Picard heap of the generalised anti-Yetter–Drinfeld modules to the heap of pivotal structures of $Z(\mathcal{C})$. In the end of the section, we answer a question of Shimizu, by proving that this morphism is not surjective in general.

In the following, \mathcal{C} denotes a strict rigid category.

4.1. Twisted centres and their Picard heaps. The regular action is not the only way in which we can consider \mathcal{C} as a bimodule over itself. Given two strict monoidal endofunctors $L, R: \mathcal{C} \rightarrow \mathcal{C}$, we can ‘twist’ the action by defining for all $V, W, X, Y \in \mathcal{C}$ and $f: V \rightarrow W, g: X \rightarrow Y$,

$$(4.1) \quad \begin{aligned} X \triangleright Y &:= L(X) \otimes Y, & f \triangleright g &:= L(f) \otimes g, \\ Y \triangleleft X &:= Y \otimes R(X), & g \triangleleft f &:= g \otimes R(f). \end{aligned}$$

We write ${}_L\mathcal{C}_R$ for the bimodule obtained in this manner and call it the *bimodule obtained by twisting with L from the left and R from the right* or, if the functors L and R are apparent from the context, simply a *twisted bimodule*. Accordingly, we refer to $Z({}_L\mathcal{C}_R)$ as a *twisted centre*. In case we want to stress that L or R are the identity functors, we write $\mathcal{C}_R := \text{Id}_{\mathcal{C}}\mathcal{C}_R$ and ${}_L\mathcal{C} := {}_L\mathcal{C}\text{Id}_{\mathcal{C}}$ and speak of a *right* and *left* twisted bimodule, respectively. Following this pattern, $Z(\mathcal{C}_R)$ and $Z({}_L\mathcal{C})$ are called *right* and *left* twisted centres.

The forgetful functor from the centre of a twisted bimodule to the underlying monoidal category is faithful. Therefore, we can use the graphical calculus discussed previously as long as we pay special attention to the half-braidings. Given that we will often deal with multiple twisted centres at once, we introduce a colouring scheme to help us keep track of the various categories:

- (i) Red for objects in the right twisted centre $Z(\mathcal{C}_R)$,
- (ii) blue for objects in the left twisted centre $Z({}_L\mathcal{C})$, and
- (iii) black for objects in the Drinfeld centre $Z(\mathcal{C})$ or \mathcal{C} .

For example, the half-braidings of objects $A \in Z(\mathcal{C}_R)$ and $Q \in Z({}_L\mathcal{C})$ are:

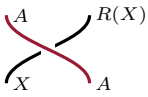
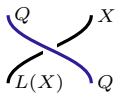
	
The half-braiding $\sigma_{A,X}: A \otimes R(X) \rightarrow X \otimes A$.	The half-braiding $\sigma_{Q,X}: Q \otimes X \rightarrow L(X) \otimes Q$.

Remark 4.1. One can easily imagine a more involved setting than what is described above by twisting with an oplax monoidal functor $(L, \Delta, \varepsilon): \mathcal{C} \rightarrow \mathcal{C}$ from the left and a lax monoidal functor (R, μ, η) from the right. We hypothesise that ${}_L\mathcal{C}_R$ would be a type of ‘oplax-lax’ bimodule over \mathcal{C} , whose actions are associative and unital only up to coherent natural transformations, subject to laws as described in [Szl12, Section 2].

At least conceptually, this unifies our subsequent considerations with the centres studied in [BV12]. We will revisit these more general structures in Section 6 and for now only remark that the half-braiding of an object $X \in \mathbf{Z}(\mathcal{L}\mathcal{C}_R)$ in the centre of an ‘oplax-lax’ bimodule is a natural transformation $\sigma_{X,-} : X \otimes R(-) \rightarrow L(-) \otimes X$, which has to satisfy:

(4.2)	
	$\begin{aligned} & (\Delta_{X,Y} \otimes \text{id}_W) \sigma_{W,X \otimes Y} (\text{id}_W \otimes \mu_{X,Y}) \\ &= (\text{id}_{L(X)} \otimes \sigma_{W,Y}) (\sigma_{W,X} \otimes \text{id}_{R(Y)}) \end{aligned}$
	$(\epsilon \otimes \text{id}_W) \sigma_{W,1} (\text{id}_W \otimes \eta) = \text{id}_W$

Convention. In what follows, we are predominantly interested in twisting with the same strict monoidal functor from the left or right. For the purpose of brevity, we therefore fix such a functor $T : \mathcal{C} \rightarrow \mathcal{C}$ and consider the categories ${}_T\mathcal{C}$ and \mathcal{C}_T .

Suppose we are given three objects

$$(A, \sigma_{A,-}) \in \mathbf{Z}(\mathcal{C}_T), \quad (Q, \sigma_{Q,-}) \in \mathbf{Z}({}_T\mathcal{C}) \quad \text{and} \quad (X, \sigma_X) \in \mathbf{Z}(\mathcal{C}).$$

The diagrams below show that various tensor products of the underlying objects in \mathcal{C} admit ‘canonical’ half-braidings.

(4.3)		
	$\sigma_{Q \otimes X, Y} : Q \otimes X \otimes Y \rightarrow T(Y) \otimes Q \otimes X$	$\sigma_{X \otimes A, Y} : X \otimes A \otimes T(Y) \rightarrow Y \otimes X \otimes A$
	$\sigma_{Q \otimes A, Y} : Q \otimes A \otimes T(Y) \rightarrow T(Y) \otimes Q \otimes A$	$\sigma_{A \otimes Q, Y} : A \otimes Q \otimes Y \rightarrow Y \otimes A \otimes Q$

The top row suggests a right action of $\mathbf{Z}(\mathcal{C})$ on left twisted centres and a left action on right twisted centres.

Theorem 4.2. *The tensor product of \mathcal{C} extends to a right and left action of the Drinfeld centre $\mathbf{Z}(\mathcal{C})$ on $\mathbf{Z}(\mathcal{C}_T)$ and $\mathbf{Z}({}_T\mathcal{C})$, respectively. The half-braidings are as defined in Diagram (4.3).*

Remark 4.3. Right and left twisted centres are two sides of the same coin. We write $\bar{\mathcal{C}} := \mathcal{C}^{\text{op}, \otimes\text{-op}}$. A direct computation proves the categories $\mathbf{Z}(\bar{\mathcal{C}}_T)$ and $\mathbf{Z}({}_T\bar{\mathcal{C}})^{\text{op}}$ to be the same. This identification is compatible with the respective actions since $- \otimes^{\text{op}} T(-) = T(-) \otimes -$ and $\sigma_{X \otimes^{\text{op}} A, -} = \sigma_{A \otimes X, -}$ for all $X \in \mathbf{Z}(\mathcal{C})$ and $A \in \mathbf{Z}(\bar{\mathcal{C}}_T)$. According to these considerations, from now on we deliberately restrict ourselves to the study of right twisted centres.

The left dual A^\vee of any object $(A, \sigma_{A,-}) \in \mathcal{Z}(\mathcal{C}_T)$ can be turned into an object of $\mathcal{Z}({}_T\mathcal{C})$ if we equip it with the half-braiding

$$(4.4) \quad \begin{array}{c} \begin{array}{c} \text{Diagram showing a half-braiding } \sigma_{A^\vee, X} \text{ between } A^\vee \text{ and } X. \text{ The diagram consists of two strands, } A^\vee \text{ (left) and } X \text{ (right). The } X \text{ strand crosses over the } A^\vee \text{ strand. The crossing is labeled } A. \text{ The } X \text{ strand continues to the right and then curves back to the left, crossing over the } A^\vee \text{ strand again. The } A^\vee \text{ strand continues to the left and then curves back to the right, crossing over the } X \text{ strand again. The crossing is labeled } R(X). \text{ The } A^\vee \text{ strand ends at } A^\vee \text{ and the } X \text{ strand ends at } A^\vee. \end{array} \\ \hline \sigma_{A^\vee, X}: A^\vee \otimes X \rightarrow R(X) \otimes A^\vee. \end{array}$$

The relation between the duality of twisted centres and their underlying categories is stated more conceptually in our next result. It can be seen as an analogue of Theorem 2.23.

Theorem 4.4. *The left dualising functor $(-)^\vee: \mathcal{C} \rightarrow \mathcal{C}^{\text{op}, \otimes\text{-op}}$ lifts to a functor between right and left twisted centres*

$$(4.5) \quad (-)^\vee: \mathcal{Z}(\mathcal{C}_T) \rightarrow \mathcal{Z}({}_T\mathcal{C})^{\text{op}}.$$

The half-braidings displayed in the right column of Diagram (4.3) show that every object $(A, \sigma_{A,-}) \in \mathcal{Z}(\mathcal{C}_T)$ gives rise to two functors of left modules over $\mathcal{Z}(\mathcal{C})$,

$$(4.6) \quad - \otimes A: \mathcal{Z}(\mathcal{C}) \rightarrow \mathcal{Z}(\mathcal{C}_T) \quad \text{and} \quad - \otimes A^\vee: \mathcal{Z}(\mathcal{C}_T) \rightarrow \mathcal{Z}(\mathcal{C}).$$

Before we prove that the adjunction $- \otimes A: \mathcal{C} \rightleftarrows \mathcal{C} : - \otimes A^\vee$, discussed in Theorem 2.8, lifts to an adjunction of module categories, we fix our notation for the evaluation and coevaluation morphisms in the context of twisted centres. For any object $(A, \sigma_{A,-}) \in \mathcal{Z}(\mathcal{C}_T)$, we write

$$(4.7) \quad \begin{array}{c} \begin{array}{c} \text{Diagram showing the evaluation morphism } \text{ev}_A^l: A^\vee \otimes A \rightarrow 1. \text{ The diagram consists of two strands, } A^\vee \text{ (left) and } A \text{ (right). The } A \text{ strand crosses over the } A^\vee \text{ strand. The crossing is labeled } A. \text{ The } A^\vee \text{ strand continues to the left and then curves back to the right, crossing over the } A \text{ strand again. The crossing is labeled } A. \text{ The } A^\vee \text{ strand ends at } 1 \text{ and the } A \text{ strand ends at } 1. \end{array} \quad =: \quad \begin{array}{c} \text{Diagram showing the evaluation morphism } \text{ev}_A^l: A^\vee \otimes A \rightarrow 1. \text{ The diagram consists of a box labeled } \text{ev}_A^l \text{ with } A^\vee \text{ on the top and } A \text{ on the bottom. A vertical dashed line labeled } 1 \text{ goes from the top of the box to the top of the diagram. A vertical dashed line labeled } 1 \text{ goes from the bottom of the box to the bottom of the diagram.} \end{array} \\ \hline \text{ev}_A^l: A^\vee \otimes A \rightarrow 1, \quad \quad \quad \text{coev}_A^l: 1 \rightarrow A \otimes A^\vee. \end{array}$$

Theorem 4.5. *Every object $(A, \sigma_{A,-}) \in \mathcal{Z}(\mathcal{C}_T)$ induces adjoint $\mathcal{Z}(\mathcal{C})$ -module functors*

$$(4.8) \quad - \otimes A: \mathcal{Z}(\mathcal{C}) \rightleftarrows \mathcal{Z}(\mathcal{C}_T) : - \otimes A^\vee.$$

Proof. We fix an object $(A, \sigma_{A,-}) \in \mathcal{Z}(\mathcal{C}_T)$. Considered as endofunctors of \mathcal{C} , there is an adjunction $- \otimes A: \mathcal{Z}(\mathcal{C}) \rightleftarrows \mathcal{Z}(\mathcal{C}_T) : - \otimes A^\vee$. As stated in the proof of Theorem 2.8, its unit and counit are implemented via the evaluation and coevaluation morphisms

$$\begin{aligned} \eta_Y &:= \text{id}_Y \otimes \text{coev}_A^l: Y \rightarrow Y \otimes A^\vee \otimes A, & \text{for all } Y \in \mathcal{Z}(\mathcal{C}), \\ \epsilon_X &:= \text{id}_X \otimes \text{ev}_A^l: X \otimes A^\vee \otimes A \rightarrow X, & \text{for all } X \in \mathcal{Z}(\mathcal{C}_T). \end{aligned}$$

The next diagram shows that ϵ_X is a morphism in $Z(\mathcal{C}_T)$ for every $X \in Z(\mathcal{C}_T)$.

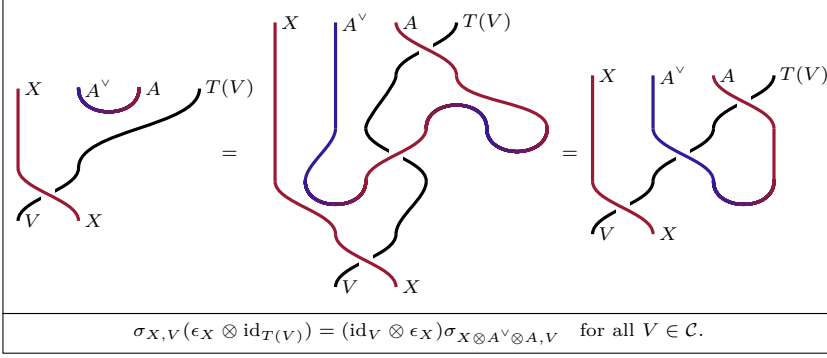
(4.9) 

$$\sigma_{X,V}(\epsilon_X \otimes \text{id}_{T(V)}) = (\text{id}_V \otimes \epsilon_X) \sigma_{X \otimes A^\vee \otimes A, V} \quad \text{for all } V \in \mathcal{C}.$$

Furthermore, $\epsilon_{W \triangleright X} = \text{id}_W \otimes \epsilon_X$ for all $W \in Z(\mathcal{C})$. A similar argument shows that the unit of the adjunction is a natural transformation of module functors as well. \square

The forgetful functor from the (twisted) centre to its underlying category is *conservative*, i.e. it ‘reflects’ isomorphisms. This allows us to characterise equivalences of module categories between $Z(\mathcal{C})$ and right twisted centres.

Theorem 4.6. *Any functor of left module categories $F: Z(\mathcal{C}) \rightarrow Z(\mathcal{C}_T)$ is naturally isomorphic to*

$$- \otimes A: Z(\mathcal{C}) \rightarrow Z(\mathcal{C}_T), \quad \text{with } A = F(1) \in Z(\mathcal{C}_T).$$

As a consequence, F is an equivalence if and only if A is invertible as an object of \mathcal{C} .

Proof. The first claim is an immediate consequence of the unitality of the action. Suppose that $H \cong - \otimes A$ is an equivalence. By Theorem 2.8, A must be invertible. If conversely A is invertible, the same theorem shows that $- \otimes A$ is an equivalence of categories. \square

Definition 4.7. An object $(A, \sigma_{(A, -)}) \in Z(\mathcal{C}_T)$ in a twisted centre of \mathcal{C} is called *\mathcal{C} -invertible* if A is invertible in \mathcal{C} .

The notion of heaps allows us to define an algebraic structure on the isomorphism classes of objects implementing module equivalences between the Drinfeld centre $Z(\mathcal{C})$ and its twisted ‘relative’ $Z(\mathcal{C}_T)$. In analogy with the Picard group, we call this the *Picard heap* of a twisted centre.

Lemma 4.8. *The Picard heap of the right twisted centre $Z(\mathcal{C}_T)$ is the set*

$$(4.10) \quad \text{Pic } Z(\mathcal{C}_T) := \{[(\alpha, \sigma_{\alpha, -})] \mid (\alpha, \sigma_{\alpha, -}) \in Z(\mathcal{C}_T) \text{ with } \alpha \text{ invertible in } \mathcal{C}\}$$

together with the heap multiplication defined for $[\alpha], [\beta], [\gamma] \in \text{Pic } Z(\mathcal{C}_T)$ by

$$(4.11) \quad \langle [\alpha], [\beta], [\gamma] \rangle = [\alpha \otimes \beta^\vee \otimes \gamma].$$

Proof. The generalised associativity, see Equation (3.1), follows from the associativity of the tensor product of \mathcal{C} and its compatibility with the ‘gluing’ of half-braidings. To show that the Mal’cev identities hold, we fix objects $\alpha, \beta \in Z(\mathcal{C}_T)$, which are invertible in \mathcal{C} . Theorem 2.23 and Equation (4.9) imply that

$$\alpha \otimes \alpha^\vee \otimes \beta \xrightarrow{\text{coev}_\alpha^{l-1} \otimes \text{id}_\beta} \beta \quad \text{and} \quad \beta \otimes \alpha^\vee \otimes \alpha \xrightarrow{\text{id}_\beta \otimes \text{ev}_\alpha^l} \beta$$

are isomorphisms in $Z(\mathcal{C}_T)$ and therefore $\langle [\alpha], [\alpha], [\beta] \rangle = [\beta] = \langle [\beta], [\alpha], [\alpha] \rangle$. \square

In general, the twisted centre $Z(\mathcal{C}_T)$ does not inherit a monoidal structure from \mathcal{C} . The above lemma, however, hints towards a slight generalisation where the tensor product is replaced by a trivalent functor, essentially categorifying heaps (without the Mal'cev identities). The well-definedness of this concept was hinted at in [Ško07] under the name of *heap categories*.

4.2. Quasi-pivotality. A particularly interesting consequence of our previous findings arises in case $T = (-)^{\vee\vee}$ is the left bidualising functor. The centre of the regular bimodule twisted on the right by $(-)^{\vee\vee}$ can be understood as a generalisation of anti-Yetter–Drinfeld modules, see [HKS19, Theorem 2.3]¹².

As before, we fix a strict rigid category \mathcal{C} and consider the twisted bimodules $\mathcal{C}_{(-)^{\vee\vee}}$ and $(-)^{\vee\vee}\mathcal{C}$.

Notation 4.9. We denote by $A(\mathcal{C}) := Z(\mathcal{C}_{(-)^{\vee\vee}})$ and $Q(\mathcal{C}) := Z((-)^{\vee\vee}\mathcal{C})$ the centre of the regular bimodule twisted by the biduality functor from the right and left, respectively. The former will also be called the *anti-Drinfeld centre* of \mathcal{C} .

We have already mentioned the connection between the twisted centre $A(\mathcal{C})$ and anti-Yetter–Drinfeld modules over Hopf algebras given in [HKS19]. The case where \mathcal{C} is the category of modules over a Hopf algebroid was recently investigated by Kowalzig in [Kow20]. The counterpart $Q(\mathcal{C})$ of the generalised anti-Yetter–Drinfeld modules is less common in the literature but plays a crucial role in our investigation, especially in Sections 5 and 6, where we focus on the monadic point of view.

The next definition is a specific case of an unnamed construction studied in [Shi16, Section 4].

Definition 4.10. A *quasi-pivotal structure* on a rigid category \mathcal{C} is a pair (β, ρ_β) comprising an invertible object $\beta \in \mathcal{C}$ and a monoidal natural isomorphism

$$(4.12) \quad \rho_\beta: \text{Id}_{\mathcal{C}} \rightarrow \beta \otimes (-)^{\vee\vee} \otimes \beta^\vee.$$

We refer to $(\mathcal{C}, (\beta, \rho_\beta))$ as a *quasi-pivotal category*.

If \mathcal{C} is the category of finite-dimensional modules over a finite-dimensional Hopf algebra, quasi-pivotal structures have a well-known interpretation—they translate to pairs in involution. This can be deduced from a slight variation of Lemma II.5.6. The main observation being, that the invertible object β of a quasi-pivotal structure (β, ρ_β) on \mathcal{C} corresponds to a character and ρ_β determines a group-like element. The fact that ρ_β is a natural transformation from the identity to a conjugate of the bidual functor is captured by the character and group-like implementing the square of the antipode. We study a monadic analogue of this statement in Section 6.4.

Remark 4.11. Every pivotal category is quasi-pivotal; the converse does not hold. A counterexample are the finite-dimensional modules over the generalised Taft algebras discussed in [HK19]. Any of these Hopf algebras admit pairs in involution but in general neither the character nor the group-like can be trivial. The previous discussion and Lemma II.5.6 show that $\text{Mod-}H$ is quasi-pivotal but not pivotal—in contrast to its Drinfeld centre $Z(\text{Mod-}H)$, which admits a pivotal structure by Lemma II.5.5.

¹²More precisely, let H be a Hopf algebra with invertible antipode. Denote by $\mathcal{C} = \text{Mod-}H$ the category of finite-dimensional right modules over H . The same arguments as given in [Kas95, Chapter XII.5] show that $A(\mathcal{C})$ is equivalent to the category ${}^H\mathcal{A}\mathcal{Y}\mathcal{D}_H$ of right-left anti-Yetter–Drinfeld modules over H as defined in [HKRS04a].

Let (β, ρ_β) be a quasi-pivotal structure on \mathcal{C} and $\phi: \beta' \rightarrow \beta$ an isomorphism. Clearly, the pair $(\beta', (\phi^{-1} \otimes \text{id} \otimes \phi^\vee)\rho_\beta)$ is another quasi-pivotal structure on \mathcal{C} . This defines an equivalence relation and we write

$$\text{QPiv}(\mathcal{C}) := \{[(\beta, \rho_\beta)] \mid (\beta, \rho_\beta) \text{ is a quasi-pivotal structure on } \mathcal{C}\}$$

for the set of equivalence classes of quasi-pivotal structures on \mathcal{C} .

Lemma 4.12. *Let \mathcal{C} be a strict rigid category. The Picard heap $\text{Pic A}(\mathcal{C})$ and the set of equivalence classes of quasi-pivotal structures $\text{QPiv}(\mathcal{C})$ are in bijection.*

Proof. Let (β, ρ_β) be a quasi-pivotal structure on \mathcal{C} . We define the half-braiding

(4.13)

$$\sigma_{\beta, X} = (\rho_{\beta, X}^{-1} \otimes \text{id}_\beta)(\text{id}_{\beta \otimes X^{\vee\vee}} \otimes (\text{ev}_\beta^l)^{-1}): \beta \otimes X^{\vee\vee} \rightarrow X \otimes \beta.$$

It satisfying the hexagon identity is due to ρ_β being monoidal. This establishes a map $\phi: \text{QPiv}(\mathcal{C}) \rightarrow \text{Pic A}(\mathcal{C})$, $[(\beta, \rho_\beta)] \mapsto [(\beta, \sigma_{\beta, -})]$.

Conversely, let $(\alpha, \sigma_{\alpha, -}) \in \text{A}(\mathcal{C})$ be \mathcal{C} -invertible. From its half-braiding we obtain a monoidal natural transformation

(4.14)

$$\rho_\alpha = (\sigma_{\alpha, X}^{-1} \otimes \text{id}_{\alpha^\vee})(\text{id}_X \otimes \text{coev}_\alpha^l): X \rightarrow \alpha \otimes X^{\vee\vee} \otimes \alpha^\vee.$$

Due to the snake identities, the map $\psi: \text{Pic A}(\mathcal{C}) \rightarrow \text{QPiv}(\mathcal{C})$, $[(\alpha, \sigma_{\alpha, -})] \mapsto [(\alpha, \rho_\alpha)]$ is the inverse of ϕ . \square

Remark 4.13. Since $\text{QPiv}(\mathcal{C})$ and $\text{Pic A}(\mathcal{C})$ are bijective, $\text{QPiv}(\mathcal{C})$ can be endowed with a heap structure. However, even if $\text{QPiv}(\mathcal{C})$ is non-empty, there might not be a canonical choice of an element to turn it into a group via the construction displayed in Lemma 3.5. This conforms to the fact that there are no canonical coefficients for Hopf-cyclic cohomology as mentioned in the introduction of this article.

Having lifted all Hopf algebraic notions of the Hajac–Sommerhäuser Theorem 1.1, we can now restate it in its categorical version. Its proof is an immediate consequence of Theorem 4.6 and Lemma 4.12.

Theorem 4.14. *Let \mathcal{C} be a strict rigid category. The following are equivalent:*

- (i) *The category \mathcal{C} is quasi-pivotal.*
- (ii) *There exists a \mathcal{C} -invertible object in $\text{A}(\mathcal{C})$.*
- (iii) *The categories $\text{Z}(\mathcal{C})$ and $\text{A}(\mathcal{C})$ are equivalent as $\text{Z}(\mathcal{C})$ -modules.*

4.3. Pivotality of the Drinfeld centre. In Remark 4.11 it is noted that pairs in involution of Hopf algebras give rise to pivotal structures on their Yetter–Drinfeld modules. This relationship follows a categorical principle, which we will examine in this section. Our approach is similar to Shimizu’s investigations in the setting of finite tensor categories, see [Shi16]. Instead of quasi-pivotal structures, it is based on the Picard heap of the anti-Drinfeld centre. Our ensuing constructions establish a conceptual understanding of the connection between elements of $\text{PicA}(\mathcal{C})$ and pivotal structures on $\mathbb{Z}(\mathcal{C})$. This in turn allows us to determine when two such induced structures coincide by studying actions of the Picard group of the symmetric centre of \mathcal{C} on $\text{PicA}(\mathcal{C})$. Ultimately, this leads to a heap morphism between the Picard heap of the anti-Drinfeld centre of \mathcal{C} and the pivotal structures on $\mathbb{Z}(\mathcal{C})$.

Let $A = (\alpha, \sigma_{\alpha, -}) \in \mathbb{A}(\mathcal{C})$ be \mathcal{C} -invertible and write $\Omega = (\omega, \sigma_{\omega, -}) \in \mathbb{Q}(\mathcal{C})$ for its left dual. The coevaluation of α will play an important role, which is why we gather some of its properties in the next diagram.

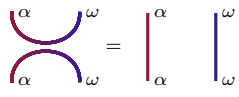
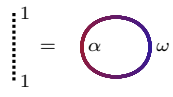
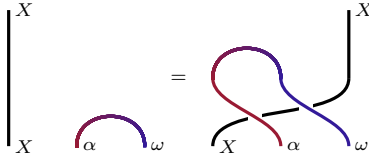
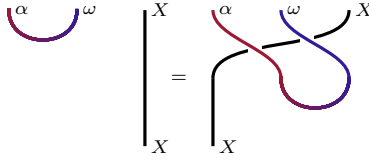
	
The coevaluation $\text{coev}_\alpha^l : 1 \rightarrow \alpha \otimes \omega$ is invertible in $\mathbb{Z}(\mathcal{C})$.	
	
Compatibility between coev_α^l and the half-braiding of $\alpha \otimes \omega$.	Compatibility between $(\text{coev}_\alpha^l)^{-1}$ and the half-braiding of $\alpha \otimes \omega$.

Appropriate half-braidings allow us to ‘entwine’ A with any object $X \in \mathbb{Z}(\mathcal{C})$ in a non-trivial manner, resulting in a morphism from X to its bidual:

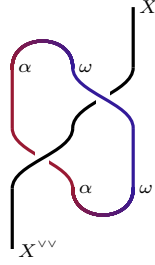
$\rho_{A,X} = (\text{id}_{X^{vv}} \otimes (\text{coev}_\alpha^l)^{-1}) (\sigma_{X,\alpha}^{-1} \otimes \text{id}_\omega) (\text{id}_\alpha \otimes \sigma_{\omega,X}) (\text{coev}_\alpha^l \otimes \text{id}_X) : X \rightarrow X^{vv}$

The following result is also discussed in [Shi16, Section 4.4]. For the convenience of the reader we will recall its proof.

Lemma 4.15. *Any \mathcal{C} -invertible object $A \in \mathbb{A}(\mathcal{C})$ of the anti-Drinfeld centre yields a pivotal structure on $\mathbb{Z}(\mathcal{C})$ via*

$$X \xrightarrow{\rho_{A,X}} X^{vv}, \quad \text{for all } X \in \mathbb{Z}(\mathcal{C}).$$

Proof. As before, we fix a \mathcal{C} -invertible object $A = (\alpha, \sigma_{\alpha, -}) \in \mathbf{A}(\mathcal{C})$ and write $\Omega = (\omega, \sigma_{\omega, -}) \in \mathbf{Q}(\mathcal{C})$ for its left dual. Furthermore, we assume $X \in \mathbf{Z}(\mathcal{C})$ to be any object in the Drinfeld centre of \mathcal{C} . We note that for any $Y \in \mathcal{C}$ a variant of the Yang–Baxter identity holds:

(4.17)

The above identity combined with those displayed in Diagram (4.15) proves that $\rho_{A,X} : X \rightarrow X^{vv}$ is a morphism in the Drinfeld centre of \mathcal{C} :

(4.18)

Since the forgetful functor $U^{(\mathbf{Z})} : \mathbf{Z}(\mathcal{C}) \rightarrow \mathcal{C}$ is conservative and $\rho_{A,X}$ is a composite of isomorphisms in \mathcal{C} , it is an isomorphism in the centre $\mathbf{Z}(\mathcal{C})$.

The naturality of the half-braidings implies that ρ_A is natural as well.

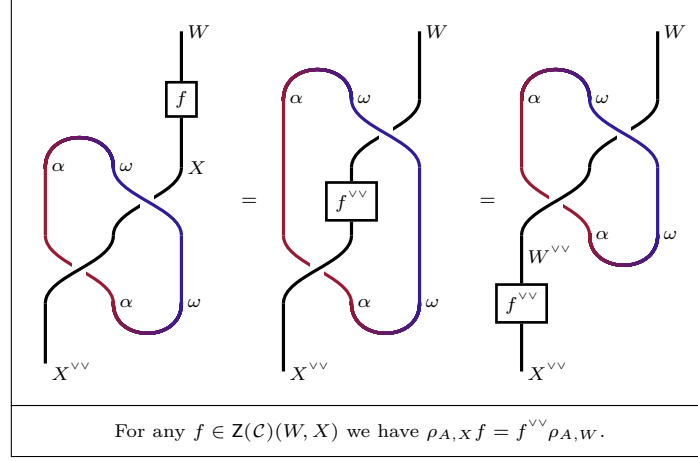

Lastly, the natural isomorphism $\rho_A: \text{Id}_{Z(\mathcal{C})} \rightarrow (-)^{\vee\vee}$ being monoidal is established by the hexagon identities, as is made evident by the next diagram.

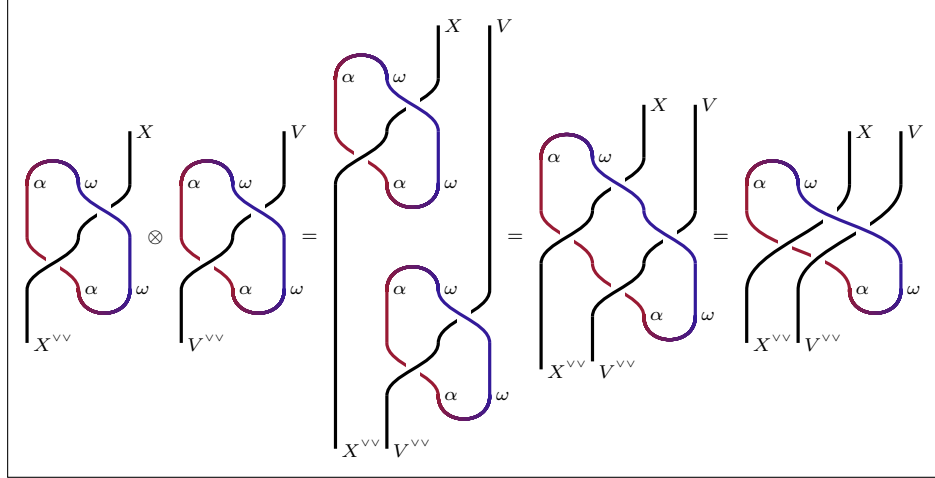

□

Our previous result tells us that at least some of the pivotal structures of $Z(\mathcal{C})$ are induced by \mathcal{C} -invertible objects in $A(\mathcal{C})$. However, it is challenging to determine a priori whether these structures coincide. The following lemma is a first step in this direction. It shows that the induced pivotal structures only depend on the isomorphism classes of \mathcal{C} -invertible objects in $A(\mathcal{C})$.

Lemma 4.16. *Let $A_1, A_2 \in A(\mathcal{C})$ be two representatives of the equivalence class $[A_1] = [A_2] \in \text{Pic } A(\mathcal{C})$. Then $\rho_{A_1} = \rho_{A_2}$.*

Proof. We fix two \mathcal{C} -invertible objects $A_{1,2} = (\alpha_{1,2}, \sigma_{\alpha_{1,2}, -}) \in A(\mathcal{C})$ such that there exists an isomorphism $\phi: A_1 \rightarrow A_2$ in the anti-Drinfeld centre. For any $X \in Z(\mathcal{C})$ we have:

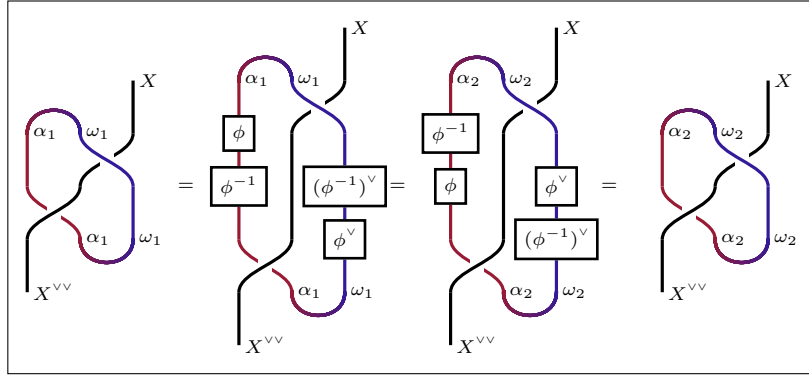

This shows that the induced pivotal structures ρ_{A_1} and ρ_{A_2} are the same. \square

Any invertible object $X \in \mathcal{Z}(\mathcal{C})$ in the Drinfeld centre allows us to define an ‘entwining’ similar to the one displayed in Equation (4.16), which we used to construct pivotal structures. If the half-braiding of X is ‘trivial’, the resulting natural isomorphism is the identity. Using this point of view, we will investigate in the following an action of objects in $\mathcal{Z}(\mathcal{C})$ of this type on the Picard heap $\text{Pic A}(\mathcal{C})$ that leaves the induced pivotal structures invariant. We begin by clarifying the notion of ‘trivial’ half-braidings.

Definition 4.17. We call an object $X \in \mathcal{Z}(\mathcal{C})$ *symmetric*¹³ if we have

$$(4.19) \quad \sigma_{X,Y}^{-1} = \sigma_{Y,X}, \quad \text{for all } Y \in \mathcal{Z}(\mathcal{C}).$$

Following the terminology of [Müg13], we call the full (symmetric) monoidal subcategory $\text{SZ}(\mathcal{C})$ of $\mathcal{Z}(\mathcal{C})$ whose objects are symmetric the *symmetric centre* of $\mathcal{Z}(\mathcal{C})$.

Lemma 4.18. *Suppose \mathcal{C} to be rigid, then $\text{SZ}(\mathcal{C})$ is rigid as well.*

Proof. Suppose $X \in \mathcal{Z}(\mathcal{C})$ to be symmetric and let $Y \in \mathcal{Z}(\mathcal{C})$. We compute

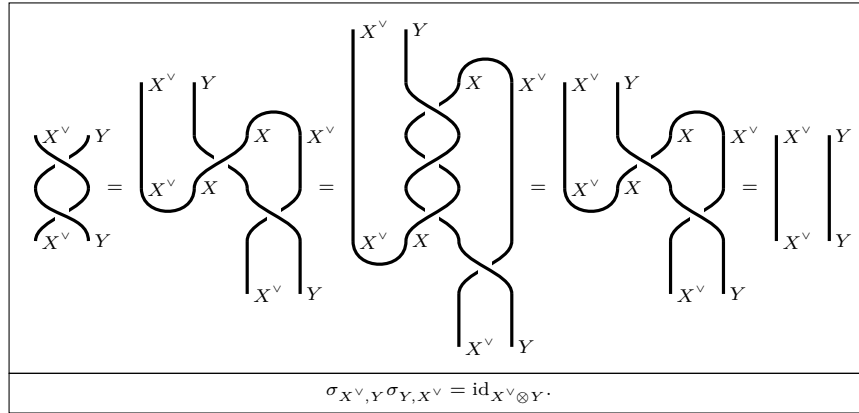

This implies $\sigma_{X^v,Y}^{-1} = \sigma_{Y,X^v}$. Since the left dual of any $X \in \text{SZ}(\mathcal{C}) \subseteq \mathcal{Z}(\mathcal{C})$ can be equipped with the structure of a right dual and $\text{SZ}(\mathcal{C})$ is a full subcategory of $\mathcal{Z}(\mathcal{C})$, it must be rigid. \square

¹³In the literature symmetric objects are also referred to as *transparent*, see for example [GR20].

Let us now consider the Picard group $\text{Pic SZ}(\mathcal{C})$ of the symmetric centre of $\mathbf{Z}(\mathcal{C})$. It acts on $\text{Pic A}(\mathcal{C})$ via tensoring from the left, as shown in Diagram (4.3). We consider two elements $A, C \in \text{Pic A}(\mathcal{C})$ equivalent if they are contained in the same orbit. That is

$$(4.20) \quad [A] \sim [C] \iff \text{there exists a } [B] \in \text{Pic SZ}(\mathcal{C}) \text{ such that } [B \otimes A] = [C].$$

To show that two elements of $\text{Pic A}(\mathcal{C})$ induce the same pivotal structure on $\mathbf{Z}(\mathcal{C})$ if and only if they are contained in the same orbit under the $\text{Pic SZ}(\mathcal{C})$ -action, we need two technical observations. First, an alternate description of symmetric invertible objects. Second, a more detailed investigation into the inverse of an induced pivotal structure.

Lemma 4.19. *An invertible object $(\beta, \sigma_{\beta, -}) \in \mathbf{Z}(\mathcal{C})$, is symmetric if and only if it satisfies for all $X \in \mathbf{Z}(\mathcal{C})$*

(4.21)

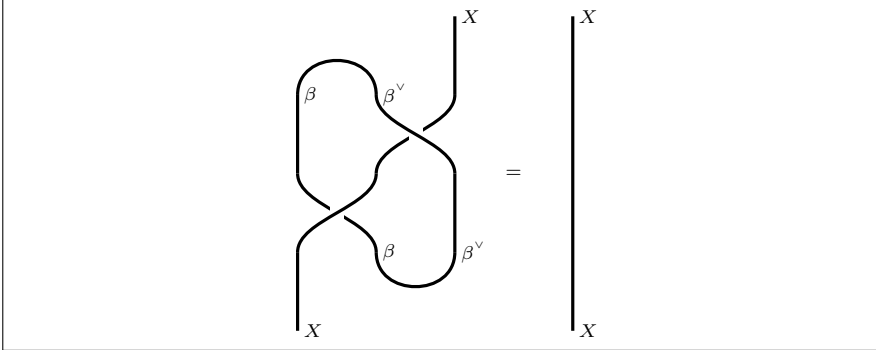

$$(\text{id}_X \otimes (\text{coev}_\beta^l)^{-1}) (\sigma_{X, \beta}^{-1} \otimes \text{id}_{\beta^v}) (\text{id}_\beta \otimes \sigma_{\beta^v, X}) (\text{coev}_\beta^l \otimes \text{id}_X) = \text{id}_X.$$

Proof. Let $B = (\beta, \sigma_{\beta, -}) \in \mathbf{Z}(\mathcal{C})$ be invertible and $X \in \mathbf{Z}(\mathcal{C})$. The left-hand side of Equation (4.21) can be rephrased as:

(4.22)

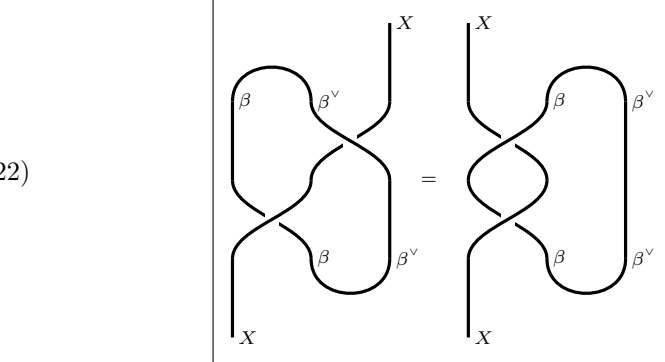

We define the morphism $f := \text{id}_X \otimes \text{coev}_\beta^l: X \rightarrow X \otimes \beta \otimes \beta^v$ and observe that Equation (4.21) is identical to

$$f^{-1} ((\sigma_{\beta, X} \sigma_{X, \beta})^{-1} \otimes \text{id}_{\beta^v}) f = \text{id}_X.$$

This is equivalent to $\sigma_{\beta, X} \sigma_{X, \beta} \otimes \text{id}_{\beta^v} = \text{id}_{X \otimes \beta} \otimes \text{id}_{\beta^v}$. As the functor $- \otimes \beta^v$ is conservative, the claim follows. \square

Lemma 4.20. Let $A = (\alpha, \sigma_{\alpha, -}) \in \mathbf{A}(\mathcal{C})$ be a \mathcal{C} -invertible object of the anti-Drinfeld centre and write $\Omega = (\omega, \sigma_{\omega, -}) \in \mathbf{Q}(\mathcal{C})$ for its dual. For any $X \in \mathbf{Z}(\mathcal{C})$, the inverse of $\rho_{A, X}$ is

(4.23)

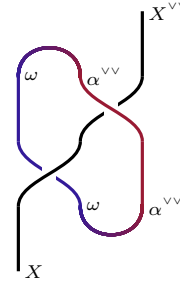

$$\rho_{\Omega, X} = (\text{id}_X \otimes (\text{coev}_\omega^l)^{-1}) (\sigma_{X, \omega}^{-1} \otimes \text{id}_{\alpha^{vv}}) (\text{id}_\omega \otimes \sigma_{\alpha^{vv}, X}) (\text{coev}_\omega^l \otimes \text{id}_{X^{vv}}) : X^{vv} \rightarrow X.$$

Proof. Let $X \in \mathbf{Z}(\mathcal{C})$. The snake identities and a variant of Equation (4.15) imply:

(4.24)

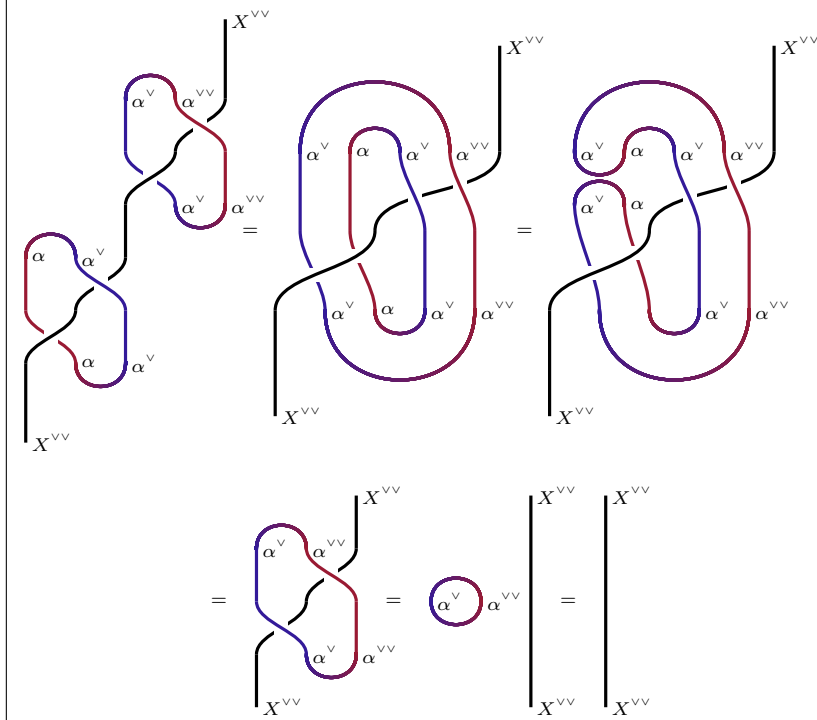

Thus, with $\Omega = (\alpha^v, \sigma_{\alpha^v, -}) \in \mathbf{Q}(\mathcal{C})$, we have $\rho_{A, X} \rho_{\Omega, X} = \text{id}_X$. \square

Lemma 4.21. Two elements $[A], [C] \in \text{Pic } \mathbf{A}(\mathcal{C})$ induce the same pivotal structure on $\mathbf{Z}(\mathcal{C})$ if and only if there exists a $[B] \in \text{Pic } \mathbf{SZ}(\mathcal{C})$ such that $[B \otimes A] = [C]$.

Proof. Let $[A], [C] \in \text{Pic } \mathcal{A}(\mathcal{C})$. Suppose there exists a $[B] \in \text{Pic } \text{SZ}(\mathcal{C})$ such that $[B \otimes A] = [C]$. For any $X \in \mathcal{Z}(\mathcal{C})$, we compute:

$$(4.25) \quad \begin{array}{c} \begin{array}{c} X^{\vee\vee} \\ | \\ \boxed{\rho_{C,X}} \\ | \\ X \end{array} = \begin{array}{c} X^{\vee\vee} \\ | \\ \beta \\ \text{---} \alpha \text{---} \omega \\ \text{---} \beta^{\vee} \\ | \\ X \end{array} = \begin{array}{c} X^{\vee\vee} \\ | \\ \beta \\ \text{---} \beta^{\vee} \\ | \\ X^{\vee\vee} \\ | \\ \boxed{\rho_{A,X}} \\ | \\ X \end{array} = \begin{array}{c} X^{\vee\vee} \\ | \\ \boxed{\rho_{A,X}} \\ | \\ X \end{array} \end{array}$$

If conversely $\rho_A = \rho_C$, we claim that $C \otimes A^\vee$ is symmetric. By Lemma 4.19 we have to show that for every $X \in \mathcal{Z}(\mathcal{C})$ the ‘entwining’ $\rho_{C \otimes A^\vee}$ of $C \otimes A^\vee$ with X is the identity and indeed we observe

$$\rho_{C \otimes A^\vee, X} = \rho_{A^\vee, X} \rho_{C, X} = \rho_{A, X}^{-1} \rho_{C, X} = \text{id}_X.$$

For the first equality we used the hexagon identities as in Equation (4.25) to separate $\rho_{C \otimes A^\vee, X}$ into two parts. The second one follows from the description of the inverse of $\rho_{A, X}$ given in Lemma 4.20. Finally, since $\text{id}_C \otimes \text{ev}_A^l: C \otimes A^\vee \otimes A \rightarrow C$ is an isomorphism in $\mathcal{A}(\mathcal{C})$, we have $[(C \otimes A^\vee) \otimes A] = [C]$. \square

The isomorphism classes of \mathcal{C} -invertible objects of $\mathcal{A}(\mathcal{C})$ are not just a set but form the Picard heap $\text{Pic } \mathcal{A}(\mathcal{C})$. Our next lemma shows that its heap multiplication projects onto the orbits under the $\text{Pic } \text{SZ}(\mathcal{C})$ -action.

Lemma 4.22. *The canonical projection $\pi: \text{Pic } \mathcal{A}(\mathcal{C}) \rightarrow \text{Pic } \mathcal{A}(\mathcal{C}) / \text{Pic } \text{SZ}(\mathcal{C})$ induces a heap structure on the set of equivalence classes $\text{Pic } \mathcal{A}(\mathcal{C}) / \text{Pic } \text{SZ}(\mathcal{C})$.*

Proof. The claim follows from a general observation. Let $X \in \mathcal{Z}(\mathcal{C})$ and $A \in \mathcal{A}(\mathcal{C})$. The half-braiding $\sigma_{X, A}: X \otimes A \rightarrow A \otimes X$ is an isomorphism in $\mathcal{A}(\mathcal{C})$:

$$(4.26) \quad \begin{array}{c} \begin{array}{c} X \quad A \quad Y^{\vee\vee} \\ \text{---} \text{---} \text{---} \\ \text{---} \text{---} \text{---} \\ Y \quad A \quad X \end{array} = \begin{array}{c} X \quad A \quad Y^{\vee\vee} \\ \text{---} \text{---} \text{---} \\ \text{---} \text{---} \text{---} \\ Y \quad A \quad X \end{array} = \begin{array}{c} X \quad A \quad Y^{\vee\vee} \\ \text{---} \text{---} \text{---} \\ \text{---} \text{---} \text{---} \\ Y \quad A \quad X \end{array} = \begin{array}{c} X \quad A \quad Y^{\vee\vee} \\ \text{---} \text{---} \text{---} \\ \text{---} \text{---} \text{---} \\ Y \quad A \quad X \end{array} \\ \hline (\sigma_{A \otimes X, Y})(\sigma_{X, A} \otimes \text{id}_{Y^{\vee\vee}}) = (\text{id}_Y \otimes \sigma_{X, A}) \sigma_{X \otimes A, Y} \quad \text{for all } Y \in \mathcal{C}. \end{array}$$

Likewise, $\sigma_{X, A^\vee}: X \otimes A^\vee \rightarrow A^\vee \otimes X$ is an isomorphism in $\mathcal{Q}(\mathcal{C})$. As a consequence, for all $[A], [A'], [A''] \in \text{Pic } \mathcal{A}(\mathcal{C})$ and $[B], [B'], [B''] \in \text{Pic } \text{SZ}(\mathcal{C})$ we have

$$\begin{aligned} \pi(\langle [A], [A'], [A''] \rangle) &= \pi(\langle [A \otimes A'^\vee \otimes A''] \rangle) = \pi(\langle [B \otimes B'^\vee \otimes B'' \otimes A \otimes A'^\vee \otimes A''] \rangle) \\ &= \pi(\langle [B \otimes A \otimes (B' \otimes A')^\vee \otimes B'' \otimes A''] \rangle) = \pi(\langle [B \otimes A], [B' \otimes A'], [B'' \otimes A''] \rangle). \end{aligned}$$

\square

Recall that due to Example 3.6, the pivotal structures $\text{Piv } \mathcal{Z}(\mathcal{C})$ on $\mathcal{Z}(\mathcal{C})$ admit a heap multiplication. This allows us to distil our previous observations into a single result.

Theorem 4.23. *The morphism of heaps*

$$(4.27) \quad \kappa: \text{Pic } \mathcal{A}(\mathcal{C}) \rightarrow \text{Piv } \mathcal{Z}(\mathcal{C}), \quad [A] \mapsto \rho_A$$

induces a unique injective morphism $\iota: \text{Pic } \mathcal{A}(\mathcal{C})/\text{Pic } \mathcal{SZ}(\mathcal{C}) \rightarrow \text{Piv } \mathcal{Z}(\mathcal{C})$ such that the following diagram commutes in the category of heaps:

$$(4.28) \quad \begin{array}{ccc} \text{Pic } \mathcal{A}(\mathcal{C}) & \xrightarrow{\kappa} & \text{Piv } \mathcal{Z}(\mathcal{C}) \\ \downarrow \pi & \searrow \exists! \iota & \\ \text{Pic } \mathcal{A}(\mathcal{C})/\text{Pic } \mathcal{SZ}(\mathcal{C}) & & \end{array}$$

Proof. Lemmas 4.15 and 4.16 show that κ is well-defined. Given three elements $[A], [B], [C] \in \text{Pic } \mathcal{A}(\mathcal{C})$, we compute

$$\kappa(\langle [A], [B], [C] \rangle) = \rho_{A \otimes B^\vee \otimes C} = \rho_A \rho_{B^\vee} \rho_C = \rho_A \rho_B^{-1} \rho_C = \langle \rho_A, \rho_B^{-1}, \rho_C \rangle.$$

Here we applied the hexagon identities as in Equation (4.25) for the second step and Lemma 4.20 for the third one. We see, κ is a morphism of heaps. Lemma 4.21 states that for any two elements $[A], [B] \in \text{Pic } \mathcal{A}(\mathcal{C})$ we have $\kappa([A]) = \kappa([B])$ if and only if $\pi([A]) = \pi([B])$. It follows from Lemma 4.22 that the unique injective map $\iota: \text{Pic } \mathcal{A}(\mathcal{C})/\text{Pic } \mathcal{SZ}(\mathcal{C}) \rightarrow \text{Piv } \mathcal{Z}(\mathcal{C})$, which lets Diagram (4.28) commute, is a morphism of heaps. \square

Remark 4.24. The centre $\mathcal{Z}(\mathcal{C})$ of a *finite tensor category* \mathcal{C} over an algebraically closed field is factorisable due to [ENO04, Proposition 4.4]. By [Shi19, Theorem 1.1], the Picard group $\text{Pic } \mathcal{SZ}(\mathcal{C})$ is trivial. In this setting, the induced pivotal structures depend only on the Picard heap $\text{Pic } \mathcal{A}(\mathcal{C})$ and not on a quotient thereof.

On the other side of the spectrum, one might consider the discrete category \mathcal{G} of an abelian group G ; its set of objects is G and all morphisms are identities. The category \mathcal{G} is rigid monoidal with the tensor product given by the multiplication of G and the left and right duals given by the respective inverses. A direct computation shows that $\mathcal{SZ}(\mathcal{G}) = \mathcal{Z}(\mathcal{G}) \cong \mathcal{G}$. Since \mathcal{G} is skeletal¹⁴ and every object is invertible, we have $\text{Pic } \mathcal{SZ}(\mathcal{G}) \cong G$. As the biduality and identity functor on \mathcal{G} coincide, the same argument implies $\text{Pic } \mathcal{A}(\mathcal{G}) \cong G$ and thus $\text{Pic } \mathcal{A}(\mathcal{G})/\text{Pic } \mathcal{SZ}(\mathcal{G}) \cong \{1\}$.



It was proven by Shimizu in [Shi16, Theorem 4.1] that under certain circumstances all pivotal structures on the centre of \mathcal{C} are induced by the quasi-pivotal structures of \mathcal{C} . In our terminology, his result can be formulated as:

Theorem 4.25. *The map $\iota: \text{Pic } \mathcal{A}(\mathcal{C})/\text{Pic } \mathcal{SZ}(\mathcal{C}) \rightarrow \text{Piv } \mathcal{Z}(\mathcal{C})$ is bijective if \mathcal{C} is a finite tensor category.*

However, in the introduction of [Shi16] the author states that it is not to be expected that this does hold true in general. In the remainder of this section, we will construct an explicit counterexample. The key observation needed to find a fitting category \mathcal{C} is the following: Suppose there is an object $X \in \mathcal{C}$ which can be endowed with two different half-braidings $\sigma_{X,-}$ and $\chi_{X,-}$. Assume furthermore that there is a pivotal structure $\zeta: \text{Id}_{\mathcal{Z}(\mathcal{C})} \rightarrow (-)^{\vee\vee}$ on $\mathcal{Z}(\mathcal{C})$ such that $\zeta_{(X, \sigma_{X,-})} \neq \zeta_{(X, \chi_{X,-})}$ as morphisms in \mathcal{C} . If the unit of \mathcal{C} is the only invertible object, there is no (quasi-)pivotal structure inducing ζ and therefore $\iota: \text{Pic } \mathcal{A}(\mathcal{C})/\text{Pic } \mathcal{SZ}(\mathcal{C}) \rightarrow \text{Piv } \mathcal{Z}(\mathcal{C})$ cannot be surjective.

¹⁴A category \mathcal{C} is *skeletal* if the only isomorphisms are identities or, put differently, $X \cong Y$ implies $X = Y$ for all objects $X, Y \in \mathcal{C}$.

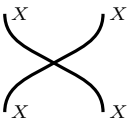
We will now define such a category \mathcal{C} in terms of generators and relations. The details of this type of construction are explained in [Kas95, Chapter XII]. As a first step, consider a ‘free’ monoidal category $\mathcal{C}^{\text{free}}$. Its objects are monomials in the variable X . Their tensor product is given by $X^n \otimes X^m = X^{n+m}$. The morphisms of $\mathcal{C}^{\text{free}}$ are formal compositions and tensor products of ‘atomic’ building blocks, subject to suitable associativity and unitality relations. These ‘atoms’ are identities on objects plus the set \mathfrak{M} of *generating morphisms* depicted below.



				
(4.29)	$\rho_X : X \rightarrow X$	$\sigma_{X,X} : X^2 \rightarrow X^2$	$\text{ev}_X : X^2 \rightarrow 1$	$\text{coev}_X : 1 \rightarrow X^2$

By [Kas95, Lemma XII.1.2], every morphism $f : X^n \rightarrow X^m$ in $\mathcal{C}^{\text{free}}$ is either the identity or can be written as

$$f = (\text{id}_{X^{j_l}} \otimes f_l \otimes \text{id}_{X^{i_l}}) \dots (\text{id}_{X^{j_2}} \otimes f_2 \otimes \text{id}_{X^{i_2}}) (\text{id}_{X^{j_1}} \otimes f_1 \otimes \text{id}_{X^{i_1}}),$$

where $i_1, j_1, \dots, i_l, j_l \in \mathbb{N}$ and $f_1, \dots, f_l \in \mathfrak{M}$. Such a presentation is not unique but the number $l \in \mathbb{N}$ of generating morphisms needed to write f in such a manner is. We call it the *degree* of f and write $\text{deg}(f) = l$.

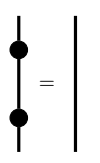
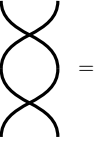
To pass to the category \mathcal{C} , we take a quotient of $\mathcal{C}^{\text{free}}$ by the relations depicted below. This will turn \mathcal{C} into a pivotal, strict rigid category and allow us to extend σ to a braiding. To increase readability, we omit labelling the strings with X .

				
(4.30)				

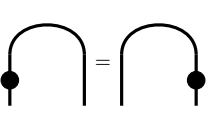
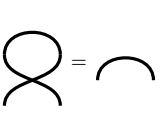
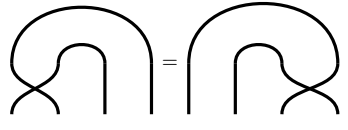
		
(4.31)		

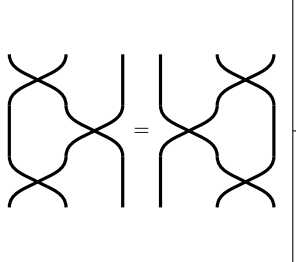
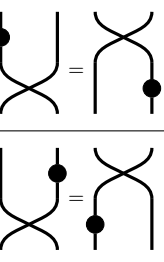
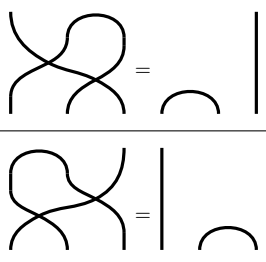
		
(4.32)		

Due to [Kas95, Proposition XII.1.4], we observe that there is a unique functor $P : \mathcal{C}^{\text{free}} \rightarrow \mathcal{C}$ which maps objects to themselves and generating morphisms to their respective equivalence classes.

Definition 4.26. Consider a morphism $f \in \text{Hom}_{\mathcal{C}}(X^n, X^m)$. A *presentation* of f is a morphism $g \in \text{Hom}_{\mathcal{C}^{\text{free}}}(X^n, X^m)$ such that $f = P(g)$. If the degree of g is minimal amongst the presentations of f , we call it a *minimal presentation*.

Before we classify half-braidings of objects in \mathcal{C} by studying their minimal presentations, we first need to gather some information about the structure of \mathcal{C} .

Theorem 4.27. *The category \mathcal{C} is strict rigid and the bidualising functor is the identity. Furthermore, $\text{id}_X, \rho_X: X \rightarrow X$ can be extended to pivotal structures and $\sigma_{X,X}: X^2 \rightarrow X^2$ to a braiding.*

Proof. The evaluation and coevaluation morphisms plus their snake identities make $X \in \mathcal{C}$, and by extension every object of \mathcal{C} , its own left and right dual, respectively. Using the Relations (4.31) together with the snake identities, we compute

$$\begin{aligned} \rho_X^\vee = \rho_X = {}^\vee\rho_X, & & \sigma_{X,X}^\vee = \sigma_{X,X} = {}^\vee\sigma_{X,X}, \\ \text{ev}_X^\vee = \text{coev}_X = {}^\vee\text{ev}_X & \quad \text{and} \quad & \text{coev}_X^\vee = \text{ev}_X = {}^\vee\text{coev}_X. \end{aligned}$$

Thus, \mathcal{C} is a strict rigid category whose bidualising functor is equal to the identity.

Our candidate for a pivotal structure on \mathcal{C} , different from the trivial one, is

$$\rho: \text{Id}_{\mathcal{C}} \rightarrow \text{Id}_{\mathcal{C}} \quad \text{defined by} \quad \rho_{X^n} := \rho_X \otimes \cdots \otimes \rho_X: X^n \rightarrow X^n, \quad n \in \mathbb{N}.$$

This family of isomorphisms is compatible with the monoidal structure of \mathcal{C} by construction and we only have to investigate its naturality. It suffices to verify this property on the generators. Relations (4.32) imply that ρ_{X^2} commutes with $\sigma_{X,X}$. For the coevaluation of $X \in \mathcal{C}$ we use $\rho_X^2 = \text{id}_X$ and Equation (4.31) to compute

$$\rho_{X^2} \text{coev}_X = (\rho_X \otimes \rho_X) \text{coev}_X = (\text{id}_X \otimes \rho_X^2) \text{coev}_X = \text{coev}_X \rho_1.$$

Applying the left dualising functor, we get $\text{ev}_X \rho_{X^2} = \text{ev}_X \rho_1$. Thus, $\rho: \text{Id}_{\mathcal{C}} \rightarrow \text{Id}_{\mathcal{C}}$ defines a pivotal structure.

Lastly, we establish that $\sigma_{X,X}$ implements a braiding $\sigma: \otimes \rightarrow \otimes^{\text{op}}$ on \mathcal{C} . We set

$$\sigma_{X,X^m} := (\text{id}_X \otimes \sigma_{X,X^{m-1}})(\sigma_{X,X} \otimes \text{id}_{X^{m-1}}), \quad m \in \mathbb{N}$$

and extend this to arbitrary objects:

$$\sigma_{X^n, X^m} := (\sigma_{X^{n-1}, X^m} \otimes \text{id}_X)(\text{id}_{X^{n-1}} \otimes \sigma_{X, X^m}), \quad n, m \in \mathbb{N}.$$

As this family of isomorphisms is constructed according to the hexagon axioms, see Equations (2.19) and (2.20), we only have to prove its naturality. Again, it suffices to consider the generating morphisms. By Equation (4.32), σ is natural with respect to ρ_X , $\sigma_{X,X}$ and coev_X . The self-duality of $\sigma_{X,X}$ and $\text{coev}_X^\vee = \text{ev}_X$ imply the desired commutation between σ and ev_X . Thus σ is a braiding on \mathcal{C} . \square

We think of a generic morphism of \mathcal{C} to be of the form:

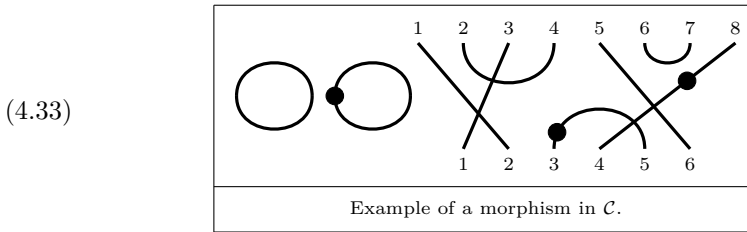

This suggest that we distinguish between *connectors*, which link an input to an output vertex, *closed loops* and *half-circles* of *evaluation-* and *coevaluation-type*.

Connectors induce a permutation on a subset of \mathbb{N} . For example, the permutation arising from Diagram (4.33) can be identified with $(1\ 2)(3\ 4)$.

Conversely, suppose $s = t_{i_1} \dots t_{i_l} \in \text{Sym}(n)$ to be a permutation written as a product of elementary transpositions and set $f_s := f_{t_{i_1}} \dots f_{t_{i_l}} : X^n \rightarrow X^n$, where

$$f_{t_i} := \text{id}_{X^{i-1}} \otimes \sigma_{X,X} \otimes \text{id}_{X^{n-(i+1)}} : X^n \rightarrow X^n, \quad \text{for } 1 \leq i \leq n-1.$$

Since the braiding σ is symmetric f_s does not depend on the presentation of s . However, should the presentation of s be minimal, then so is the corresponding presentation of f_s .

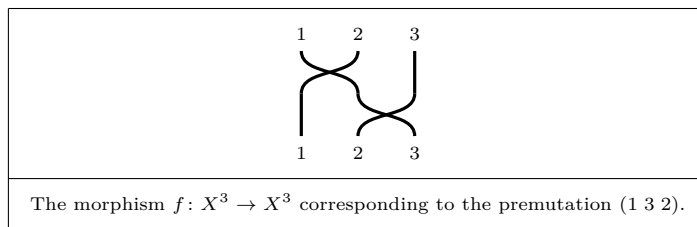

To derive a normal form of the automorphisms of \mathcal{C} and turn our previously explained thoughts into precise mathematical statements, we need to study the ‘topological features’ of the morphisms in \mathcal{C} .

Remark 4.28. We recall the *category \mathcal{T} of tangles*, a close relative to the string diagrams arising from \mathcal{C} , based on [Kas95, Chapter XII.2]. Its objects are finite sequences in $\{+, -\}$ and its morphisms are isotopy classes of oriented tangles. A detailed discussion of tangles is given in [Kas95, Definition X.5.1]. For us, it suffices to think of an oriented tangle L of type (n, m) as a finite disjoint union of embeddings of either the unit circle S^1 or the interval $[0, 1]$ into $\mathbb{R}^2 \times [0, 1]$ such that

$$(4.34) \quad \partial L = L \cap (\mathbb{R}^2 \times \{0, 1\}) = ([n] \times \{(0, 0)\}) \cup ([m] \times \{(0, 1)\}),$$

where $[n] = \{1, \dots, n\}$ and $[m] = \{1, \dots, m\}$. The orientation on each of the connected components of L is induced by the counter-clockwise orientation of S^1 and the (ascending) orientation of $[0, 1]$. The tensor product of tangles is given by pasting them next to each other. Their composition is implemented, by appropriate gluing and rescaling.

To distinguish isotopy classes of tangles, one can study their images under the projection $\mathbb{R}^2 \times [0, 1] \rightarrow \mathbb{R} \times [0, 1]$. This leads to a combinatorial description of \mathcal{T} , see for example [Kas95, Theorem XII.2.2].

Theorem 4.29. *The strict monoidal category \mathcal{T} is generated by the morphisms:*

$\text{ev}_+ : + \otimes - \rightarrow 1,$	$\text{coev}_+ : 1 \rightarrow - \otimes +,$	$\text{ev}_- : - \otimes + \rightarrow 1,$	$\text{coev}_- : 1 \rightarrow + \otimes -,$
$\tau_{+,+} : + \otimes + \rightarrow + \otimes +,$		$\tau_{+,+}^{-1} : + \otimes + \rightarrow + \otimes +.$	

These are subject to the following relations:

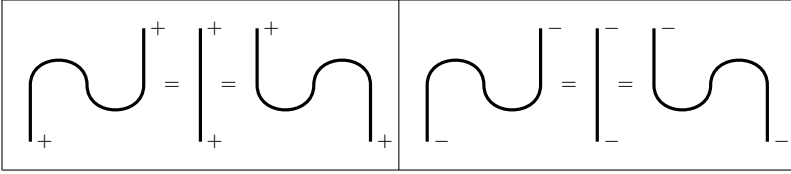
(4.35) 

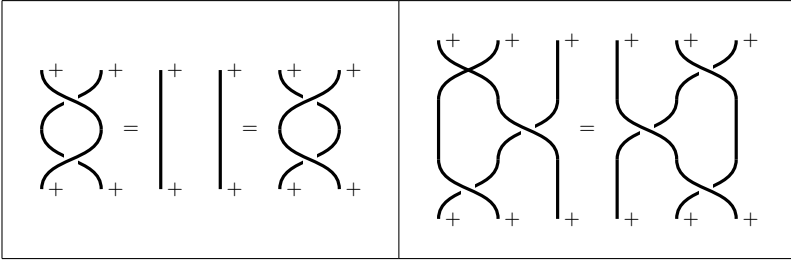
(4.36) 

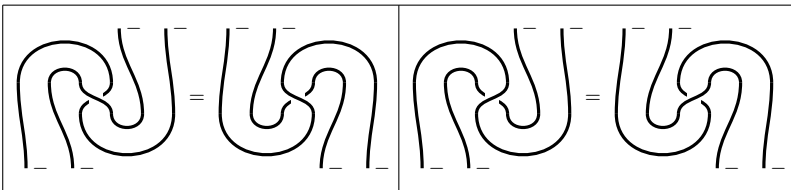
(4.37) 

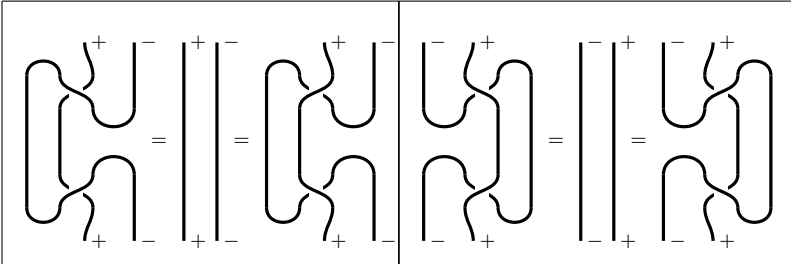
(4.38) 

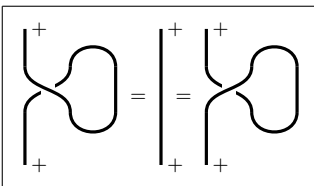
(4.39) 

The connection between tangles and the category \mathcal{C} is attained through applying [Kas95, Proposition XII.1.4].

Lemma 4.30. *There exists a strict monoidal functor $S: \mathcal{T} \rightarrow \mathcal{C}$ which is uniquely determined by $S(+)=X=S(-)$ and*

$$S(\text{ev}_{\pm}) = \text{ev}_X, \quad S(\text{coev}_{\pm}) = \text{coev}_X, \quad S(\tau_{+,+}^{\pm}) = \sigma_{X,X}.$$

To investigate the ‘topological features’ of \mathcal{C} , we want to lift its morphisms to \mathcal{T} . Hereto we want to ‘trivialise’ the generator $\rho_{X,X}: X \rightarrow X$. Set $\mathcal{C}/\langle \rho_X \rangle$ to be the category obtained from \mathcal{C} by identifying ρ_X with id_X . The ‘projection’ functor

$\text{Pr}: \mathcal{C} \rightarrow \mathcal{C}/\langle \rho_X \rangle$ allows us to define an equivalence relation on the morphisms of \mathcal{C} :

$$(4.40) \quad f \sim g \quad \iff \quad \text{Pr}(f) = \text{Pr}(g).$$

For example the following two endomorphisms $\bigcirc, \bullet\bigcirc: 1 \rightarrow 1$ of the monoidal unit of \mathcal{C} would be equivalent with respect to this relation:

$$(4.41) \quad \begin{array}{|c|c|} \hline \img alt="A simple circle representing a closed loop." data-bbox="398 238 461 281"/> & \img alt="A circle with a solid black dot on its left side, representing a closed loop decorated with rho." data-bbox="531 238 598 281"/> \\ \hline \text{A closed loop } \bigcirc. & \text{A closed loop } \bullet\bigcirc \\ & \text{decorated with } \rho. \\ \hline \end{array}$$

Theorem 4.31. *Every automorphism $f \in \mathcal{C}(X^n, X^n)$ can be uniquely written as*

$$(4.42) \quad f = f_s f_\phi,$$

where $f_s: X^n \rightarrow X^n$ is the automorphism induced by a permutation $s \in \text{Sym}(n)$ and

$$(4.43) \quad f_\phi = \rho_X^{\phi_1} \otimes \cdots \otimes \rho_X^{\phi_n}, \quad \text{with } \phi_1, \dots, \phi_n \in \mathbb{Z}_2.$$

Furthermore, if a minimal presentation $s = t_{i_1} \dots t_{i_l}$ is fixed, the resulting presentation of f is minimal as well.

Proof. For any automorphism $f \in \text{Aut}_{\mathcal{C}}(X^n)$ there exists another automorphism $g \in \text{Aut}_{\mathcal{C}}(X^n)$ such that $\text{Pr}(f) = \text{Pr}(g)$ and g has a presentation in which no copies of ρ occur. By proceeding analogous to [Kas95, Lemma X.3.3], we construct a tangle L_g out of g such that $S(L_g) = g$. Furthermore L_g is isotopic to a tangle L'_g , whose connected components are mapped under the projection $\mathbb{R}^2 \times [0, 1] \rightarrow \mathbb{R} \times [0, 1]$ either to closed loops, half-circles of evaluation- or coevaluation-type or straight lines. Write L_n^{triv} for a tangle which projects to n parallel straight lines

$$\{(k, t) \mid t \in [0, 1] \text{ and } k \in \{1, \dots, n\}\}.$$

Since g was invertible by assumption, we can lift its inverse $g^{-1}: X^n \rightarrow X^n$ to a tangle $L_{g^{-1}}$ with $[L_g][L_{g^{-1}}] = [L_n^{\text{triv}}] = [L_{g^{-1}}][L_g]$. This equation readily implies that L'_g could not have contained any loops or half-circles. In other words $g = f_s$, where f_s is the morphism obtained from the permutation $s \in \text{Sym}(n)$, induced by the projection of L'_g onto $\mathbb{R} \times [0, 1]$. Due to the naturality of $\sigma_{X, X}$, the equivalence between f and g implies $f = f_s f_\phi$, with f_ϕ being a tensor product of identities and copies of ρ_X .

The proof is concluded by showing that for all $\phi_1, \psi_1, \dots, \phi_n, \psi_n \in \mathbb{Z}_2$ we have

$$\rho^{\phi_1} \otimes \cdots \otimes \rho^{\phi_n} = \rho^{\psi_1} \otimes \cdots \otimes \rho^{\psi_n} \in \mathcal{C}(X^n, X^n) \iff \phi_1 = \psi_1, \dots, \phi_n = \psi_n.$$

Hereto we consider a 2-dimensional vector space V over a field \mathbb{k} and choose a basis $B = \{b_0, b_1\}$ of V . This allows us to construct a strong monoidal functor $F: \mathcal{C} \rightarrow \mathbb{k}\text{-Vect}$ with $F(X) = V$. For all $i, j \in \{0, 1\}$, we set

$$\begin{aligned} F(\rho_X)(b_1) &= b_0, & F(\rho_X)(b_0) &= b_1, & F(\sigma)(b_i \otimes b_j) &= b_j \otimes b_i, \\ F(\text{coev})(1_{\mathbb{k}}) &= b_0 \otimes b_0 + b_1 \otimes b_1, & F(\text{ev})(b_i \otimes b_j) &= \delta_{i=j}, \end{aligned}$$

and extend these assignments linearly. This determines the values of $F: \mathcal{C} \rightarrow \mathbb{k}\text{-Vect}$ on the set \mathfrak{M} of generating morphisms of \mathcal{C} . Identifying $\{0, 1\}$ with \mathbb{Z}_2 yields

$$F(\rho^{\phi_1} \otimes \cdots \otimes \rho^{\phi_n})(b_0 \otimes \cdots \otimes b_0) = b_{\phi_1} \otimes \cdots \otimes b_{\phi_n} \quad \text{and}$$

$$F(\rho^{\psi_1} \otimes \cdots \otimes \rho^{\psi_n})(b_0 \otimes \cdots \otimes b_0) = b_{\psi_1} \otimes \cdots \otimes b_{\psi_n}.$$

The claim follows. \square

The first step in showing that $\iota: \text{Pic A}(\mathcal{C})/\text{Pic SZ}(\mathcal{C}) \rightarrow \text{Piv Z}(\mathcal{C})$ cannot be surjective is to prove that the Picard heap $\text{Pic A}(\mathcal{C})$ contains at most two elements.

Corollary 4.32. *The only (quasi-)pivotal structures on \mathcal{C} are $\text{id}: \text{Id}_{\mathcal{C}} \rightarrow \text{Id}_{\mathcal{C}}$ and $\rho: \text{Id}_{\mathcal{C}} \rightarrow \text{Id}_{\mathcal{C}}$.*

Proof. The only invertible object of \mathcal{C} is its monoidal unit, which implies that any quasi-pivotal structure on \mathcal{C} is already pivotal. The claim follows since these are determined by their value on X and, by Theorem 4.31, $\text{Aut}_{\mathcal{C}}(X) = \{\text{id}_X, \rho_X\}$. \square

Let us now focus on the various ways in which we can equip the objects of \mathcal{C} with half-braidings. Our classification of automorphisms in \mathcal{C} allows us to easily verify that on $X \in \mathcal{C}$ there are four different half-braidings. These are determined by

$$(4.44) \quad \begin{array}{|c|c|} \hline \text{[Diagram 1]} & \text{[Diagram 2]} \\ \hline \sigma_{X,X}^{\circ,\circ}: X^2 \rightarrow X^2, & \sigma_{X,X}^{\circ,\bullet}: X^2 \rightarrow X^2 \\ \hline \end{array} \quad \text{and} \quad \begin{array}{|c|c|} \hline \text{[Diagram 3]} & \text{[Diagram 4]} \\ \hline \sigma_{X,X}^{\bullet,\circ}: X^2 \rightarrow X^2, & \sigma_{X,X}^{\bullet,\bullet}: X^2 \rightarrow X^2. \\ \hline \end{array}$$

The fact that these braidings are distinguished by the appearances of ρ on the respective strings, motivates our next definition.

Definition 4.33. Let $f = f_s f_\phi: X^n \rightarrow X^n$ be an automorphism in \mathcal{C} . Its *characteristic sequence* is $\phi := (\phi_1, \dots, \phi_n) \in (\mathbb{Z}_2)^n$ with

$$(4.45) \quad f_\phi = \rho_X^{\phi_1} \otimes \cdots \otimes \rho_X^{\phi_n}.$$

Indeed, it is the interplay between instances of ρ and the underlying permutation that determine whether an automorphism $\chi_{Y,X}: Y \otimes X \rightarrow X \otimes Y$ can be lifted to a half-braiding.

Lemma 4.34. *Any automorphism $\chi_{X^n,X}: X^n \otimes X \rightarrow X \otimes X^n$ extends to a half-braiding on $X^n \in \mathcal{C}$ if and only if there exists an $f \in \text{Aut}_{\mathcal{C}}(X^n)$ with characteristic sequence (ϕ_1, \dots, ϕ_n) and underlying permutation $s \in \text{Sym}(n)$ such that for all $1 \leq i \leq n$ we have*

$$(4.46) \quad s^2(i) = i, \quad s(\phi_i) = \phi_i,$$

and $\chi_{X^n,X} = \sigma_{X^n,X}(f \otimes \rho_X^j)$ for an integer $j \in \mathbb{Z}_2$.

Proof. Assume $\chi_{X^n,X}: Y \otimes X \rightarrow X \otimes Y$ to induce a half-braiding on X^n . Due to Theorem 4.31, we can write $\chi_{X^n,X} = \sigma_{X^n,X}(f \otimes \rho_X^j)$, where $f: X^n \rightarrow X^n$ is an automorphism of X^n and $j \in \mathbb{Z}_2$. Let $\phi = (\phi_1, \dots, \phi_n)$ be the characteristic sequence of f and $s \in \text{Sym}(n)$ its underlying permutation. We set

$$f_{s^{-1}(\phi)} = \rho_X^{s^{-1}(\phi_1)} \otimes \cdots \otimes \rho_X^{s^{-1}(\phi_n)}.$$

Writing $W := X^{n-1}$ and using that $f = f_s f_\phi$ as well as the naturality of $\chi_{X^n, -}$ and Equation (4.31), we compute:

(4.47)

This is equivalent to s being an involution and ϕ being invariant under s .

Conversely, let $\chi_{X^n, X} = \sigma_{X^n, X}(f \otimes \rho_X^j): X^n \otimes X \rightarrow X \otimes X^n$, where f is an automorphism whose characteristic sequence and underlying permutation satisfy Equation (4.46). In order to turn it into a half-braiding, we extend it to a family of isomorphisms $\chi_{X^n, -}: X^n \otimes - \rightarrow - \otimes X^n$ according to the hexagon axioms. We verify its naturality on the generators of \mathcal{C} . For ρ_X and $\sigma_{X, X}$ this is an immediate consequence of their respective naturality conditions. The necessary commutation relations between $\chi_{X^n, -}$ and coev_X as well as ev_X , can be deduced from Equation (4.47). \square

The previous lemma severely restricts the number of possibilities in which an automorphism of \mathcal{C} can lift to the centre $Z(\mathcal{C})$.

Corollary 4.35. *Consider an object $X^n \in \mathcal{C}$ equipped with two half-braidings*

$$\chi_{X^n, X} = \sigma_{X^n, X}(f_s f_\phi \otimes \rho_X^j), \quad \theta_{X^n, X} = \sigma_{X^n, X}(f_t f_\psi \otimes \rho_X^k).$$

If $g = g_r g_\lambda \in \text{Aut}_{\mathcal{C}}(X^n)$ lifts to a morphism $g: (X^n, \chi_{X^n, -}) \rightarrow (X^n, \theta_{X^n, -})$ of objects in the centre $Z(\mathcal{C})$ of \mathcal{C} , then

$$(4.48) \quad \phi_i \lambda_{sr(i)} = \psi_{r(i)} \lambda_{r(i)}, \quad \text{for all } 1 \leq i \leq n.$$

Proof. For the automorphism $g = g_r g_\lambda \in \text{Aut}_{\mathcal{C}}(X^n)$ to lift to the centre it must satisfy

$$\sigma_{X^n, X}(f_s f_\phi g \otimes \rho_X^j) = \chi_{X^n, X}(g \otimes \text{id}_X) = (\text{id}_X \otimes g)\theta_{X^n, X} = \sigma_{X^n, X}(g f_t f_\psi \otimes \rho_X^k).$$

This implies $f_s f_\phi g_r g_\lambda = g_r g_\lambda f_t f_\psi$ and therefore $\phi_{s(i)} \lambda_{sr(i)} = \lambda_{r(i)} \psi_{rt(i)}$ for all $1 \leq i \leq n$. Since \mathbb{Z}_2 is abelian and $\phi_{s(i)} = \phi_i$ as well as $\psi_{t(i)} = \psi_i$, the claim follows. \square

In view of Lemma 4.34, we state a slightly refined version of Definition 4.33.

Definition 4.36. Consider an object $Y = (X^n, \chi_{X^n, X}) \in Z(\mathcal{C})$ whose half-braiding is defined by $\chi_{X^n, X} = \sigma_{X^n, X}(f \otimes \rho_X^j)$ for an integer $j \in \mathbb{Z}_2$. We call the characteristic sequence ϕ of f the *signature* of Y .

We now construct a pivotal structure on the centre of \mathcal{C} which differs from the lifts of id and ρ from \mathcal{C} to $Z(\mathcal{C})$.

Theorem 4.37. *The Drinfeld centre $Z(\mathcal{C})$ of \mathcal{C} admits a pivotal structure ζ with*

$$(4.49a) \quad \zeta_{(X, \sigma_{X, -}^{\circ, \circ})} = \text{id}_X, \quad \zeta_{(X, \sigma_{X, -}^{\circ, \bullet})} = \text{id}_X,$$

$$(4.49b) \quad \zeta_{(X, \sigma_{X, -}^{\bullet, \circ})} = \rho_X, \quad \zeta_{(X, \sigma_{X, -}^{\bullet, \bullet})} = \rho_X.$$

Proof. For any object $Y \in Z(\mathcal{C})$ we define

$$\zeta_Y = \rho_X^{\phi_1} \otimes \cdots \otimes \rho_X^{\phi_n}, \quad \text{where } \phi = (\phi_1, \dots, \phi_n) \text{ is the signature of } Y.$$

Since the signature φ of a tensor product $Y \otimes W$ of objects $Y, W \in Z(\mathcal{C})$ is given by concatenating the signatures ϕ of Y and ψ of W , this defines a family of isomorphisms $\zeta: \text{Id}_{Z(\mathcal{C})} \rightarrow \text{Id}_{Z(\mathcal{C})}$, which is compatible with the monoidal structure. It therefore only remains to prove the naturality of ζ . This can be verified by considering all possible lifts of identities and generators of \mathcal{C} to its Drinfeld centre. For $\text{id}_X, \rho_X: X \rightarrow X$ and $\sigma_{X, X}: X^2 \rightarrow X^2$, this follows by Corollary 4.35. To study the coevaluation of X , we fix a half-braiding $\chi_{X^2, -}: X^2 \otimes - \rightarrow - \otimes X^2$ on X^2 . Due to Lemma 4.34, it is determined by

$$\chi_{X^2, X} = \sigma_{X^2, X}((\sigma_{X, X}^i(\rho_X^j \otimes \rho_X^k)) \otimes \rho_X^l), \quad \text{where } i, j, k, l \in \mathbb{Z}_2.$$

Now suppose, $\text{coev}_X: 1 \rightarrow X^2$ lifts to a morphism in $Z(\mathcal{C})$, where X^2 is equipped with this half-braiding. Relation (4.31) together with the self-duality of $\sigma_{X, X}$ imply $\sigma_{X, X} \text{coev}_X = \text{coev}_X$ and $\text{ev}_X \sigma_{X, X} = \text{ev}_X$, which allows us to compute:

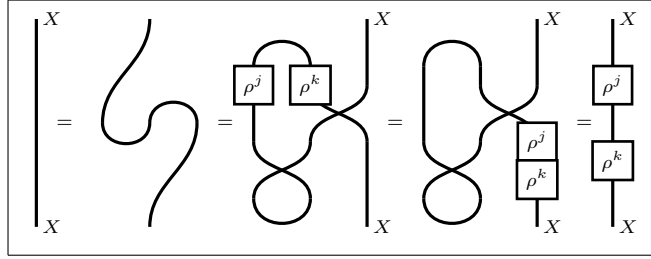

Therefore $j = k$ and $\zeta_{(X^2, \chi_{X^2, -})} = \text{id}_X^2$ or $\zeta_{(X^2, \chi_{X^2, -})} = \rho_X^2$, from which the desired naturality condition follows. A similar argument for the evaluation of X concludes the proof. \square

By Corollary 4.32, the Picard heap of $A(\mathcal{C})$ can have at most two elements. However, the above theorem constructs a third pivotal structure on $Z(\mathcal{C})$. This implies our desired result:

Theorem 4.38. *The pivotal structure ζ of $Z(\mathcal{C})$ is not induced by the Picard heap of $A(\mathcal{C})$. In particular, the map $\iota: \text{Pic } A(\mathcal{C}) / \text{Pic } \text{SZ}(\mathcal{C}) \rightarrow \text{Piv } Z(\mathcal{C})$ is not surjective.*

Let us conclude this section by stating that we deem the question interesting under which conditions on a rigid category \mathcal{C} , the map $\iota: \text{Pic } A(\mathcal{C}) / \text{Pic } \text{SZ}(\mathcal{C}) \rightarrow \text{Piv } Z(\mathcal{C})$ is surjective.

PART 2:

THE ANTI-DOUBLE OF A HOPF MONAD AND
PAIRS IN INVOLUTION

5. BIMODULE AND COMODULE MONADS

Bimonads and Hopf monads are a vast generalisation of bialgebras and Hopf algebras, respectively. They naturally arise in the study of (rigid) monoidal categories and topological quantum field theories, see amongst others [KL01, Moe02, BV07, BLV11, TV17]. While there are several, sometimes non-equivalent, constructions for Hopf monads, see [Boa95, MW11], we follow the approach of [BV07].

A monadic interpretation of module categories was given by Aguiar and Chase under the name ‘comodule monad’, see [AC12]. In this section, we recall some aspects of their theory needed to obtain a monadic version of the results in Section 4.

5.1. Monads and their representation theory. A monad is an object of algebraic nature which serves as a ‘coordinate system’ of its category of modules. That is, many properties of the latter can be expressed through the former. In this short exposition, we follow [Rie17, Chapter 5] but keep our notation in line with the article [BV07].

Definition 5.1. A *monad* on a category \mathcal{C} is an endofunctor $T: \mathcal{C} \rightarrow \mathcal{C}$ together with two natural transformations

$$\mu: T^2 \rightarrow T, \quad \eta: \text{Id}_{\mathcal{C}} \rightarrow T,$$

called the *multiplication* and *unit* of T , respectively. They need to satisfy appropriate associativity and unitality axioms, i.e. for all $X \in \mathcal{C}$

$$(5.1) \quad \mu_X(T(\mu_X)) = \mu_X(\mu_{T(X)}),$$

$$(5.2) \quad \mu_X(\eta_{T(X)}) = \text{id}_{T(X)} = \mu_X(T(\eta_X)).$$

A *morphism* of monads $f: T \rightarrow S$ is a natural transformation such that

$$(5.3) \quad f\mu_X^{(T)} = \mu^{(S)}S(f_X)f_{T(X)}, \quad f_X\eta_X^{(T)} = \eta_X^{(S)}, \quad \text{for every } X \in \mathcal{C}.$$

Remark 5.2. The endofunctors of a category \mathcal{C} form a monoidal category $\text{End}(\mathcal{C})$ with composition as its tensor product. From this point of view, monads can be interpreted as monoids (or algebras) in $\text{End}(\mathcal{C})$. In the language of string diagrams, we represent the multiplication and unit of a monad $(T, \mu, \eta): \mathcal{C} \rightarrow \mathcal{C}$ as

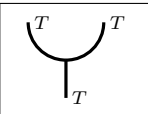
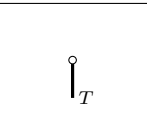
$$(5.4) \quad \begin{array}{|c|c|} \hline  &  \\ \hline \mu: T^2 \rightarrow T, & \eta: \text{Id}_{\mathcal{C}} \rightarrow T. \\ \hline \end{array}$$

Their associativity and unitality then equate to the diagrams

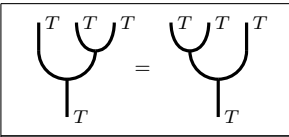
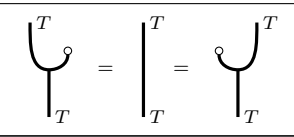
$$(5.5) \quad \begin{array}{|c|c|} \hline  &  \\ \hline \mu\mu_T = \mu T(\mu), & \mu\eta_T = \text{id}_T = \mu T(\eta). \\ \hline \end{array}$$

Definition 5.3. A *module* over a monad $(T, \mu, \eta): \mathcal{C} \rightarrow \mathcal{C}$ is an object $M \in \mathcal{C}$ together with a morphism $\vartheta_M: T(M) \rightarrow M$, called the *action* of T on M , such that

$$(5.6) \quad \vartheta_M\mu_M = \vartheta_M T(\vartheta_M) \quad \text{and} \quad \vartheta_M\eta_M = \text{id}_M.$$

A *morphism of modules over T* is a morphism $f: M \rightarrow N$ that commutes with the respective actions, i.e.

$$(5.7) \quad \vartheta_N T(f) = f \vartheta_M.$$

Modules and their morphisms over a monad T on \mathcal{C} form the category \mathcal{C}^T of *T -modules*¹⁵. The *free* and *forgetful functor* of T are

$$F_T: \mathcal{C} \rightarrow \mathcal{C}^T, \quad F_T(M) = (T(M), \mu_M^{(T)}) \quad \text{and} \quad U_T: \mathcal{C}^T \rightarrow \mathcal{C}, \quad U_T(M, \vartheta_M) = M.$$

They constitute the *Eilenberg–Moore adjunction* $F_T: \mathcal{C} \rightleftarrows \mathcal{C}^T : U_T$ of T whose unit $\eta: \text{Id}_{\mathcal{C}} \rightarrow U_T F_T$ and counit $\epsilon: F_T U_T \rightarrow \text{Id}_{\mathcal{C}^T}$ are defined by

$$(5.8a) \quad \eta_V := \eta_V^{(T)}: \text{Id}_{\mathcal{C}}(V) \rightarrow U_T F_T(V) = T(V), \quad \text{for every } V \in \mathcal{C},$$

$$(5.8b) \quad \epsilon_{(M, \vartheta_M)} := \vartheta_M: F_T U_T(M, \vartheta_M) \rightarrow \text{Id}_{\mathcal{C}^T}(M, \vartheta_M), \quad \text{for every } (M, \vartheta_M) \in \mathcal{C}^T.$$

Remark 5.4. To fit the free and forgetful functor of a monad $(T, \mu, \eta): \mathcal{C} \rightarrow \mathcal{C}$ into our graphical framework, we need a small modification: we label connected regions of the diagrams with categories. The unit and counit of the adjunction then read as

$$(5.9) \quad \begin{array}{|c|c|} \hline \begin{array}{c} \text{Id}_{\mathcal{C}} \\ \vdots \\ c \\ \boxed{\eta} \\ \vdots \\ c^T \\ \begin{array}{cc} F_T & U_T \end{array} \end{array} = \begin{array}{c} \text{Id}_{\mathcal{C}} \\ \text{U-shape} \\ \begin{array}{cc} F_T & U_T \end{array} \end{array} & \begin{array}{c} U_T \quad F_T \\ \begin{array}{c} c \\ \boxed{\epsilon} \\ c^T \end{array} \\ \text{Id}_{\mathcal{C}^T} \end{array} = \begin{array}{c} U_T \quad F_T \\ \text{U-shape} \\ \text{Id}_{\mathcal{C}^T} \end{array} \\ \hline \eta: \text{Id}_{\mathcal{C}} \rightarrow U_T F_T, & \epsilon: F_T U_T \rightarrow \text{Id}_{\mathcal{C}^T}. \end{array}$$

Since the occurring categories are often apparent from the context, we do not explicitly display them in our diagrams. With these conventions, the string diagrammatic versions of the defining Equations (2.1) and (2.2) of the above adjunction are

$$(5.10) \quad \begin{array}{|c|c|} \hline \begin{array}{c} U_T \\ \text{U-shape} \\ U_T \end{array} = \begin{array}{c} U_T \\ \text{I-shape} \\ U_T \end{array} & \begin{array}{c} F_T \\ \text{U-shape} \\ F_T \end{array} = \begin{array}{c} F_T \\ \text{I-shape} \\ F_T \end{array} \\ \hline U_T(\epsilon)\eta_{U_T} = \text{id}_{U_T}, & \epsilon_{F_T}F_T(\eta) = \text{id}_{F_T}. \end{array}$$

Likewise, we obtain a diagrammatic representation of the modules over T . By definition we have that $T = U_T F_T$ as functors. Define the natural transformation $\vartheta := U_T(\epsilon): T U_T = U_T F_T U_T \rightarrow U_T$. Following [Wil08], it will be represented by

$$(5.11) \quad \begin{array}{|c|} \hline \begin{array}{c} U_T \quad T \\ \begin{array}{c} \vdots \\ c \\ \boxed{\vartheta} \\ \vdots \\ c^T \\ U_T \end{array} \end{array} = \begin{array}{c} U_T \quad T \\ \begin{array}{c} \vdots \\ c \\ \vdots \\ U_T \end{array} \end{array} \\ \hline \vartheta: T U_T \rightarrow U_T. \end{array}$$

¹⁵In the literature, modules over T are also referred to as *T -algebras* and \mathcal{C}^T is called the *Eilenberg–Moore category* of T . The intention behind our conventions is to have a closer similarity to (Hopf) algebraic notions.

The compatibility of the action with the multiplication of T and its unitality are expressed by

(5.12)

$\vartheta\mu_{U_T} = \vartheta T(\vartheta),$	$\vartheta\eta_{U_T} = \text{id}_{U_T}.$

As witnessed above, monads lead almost naturally to adjunctions between their ‘base categories’ and their categories of modules. The situation we face, however, is the opposite. Given an adjunction $F: \mathcal{C} \rightleftarrows \mathcal{D} : U$ between two categories \mathcal{C} and \mathcal{D} , we want to find a monad on \mathcal{C} whose category of modules is equivalent to \mathcal{D} .

Lemma 5.5. *Let $F: \mathcal{C} \rightleftarrows \mathcal{D} : U$ be an adjunction between two categories \mathcal{C} and \mathcal{D} with unit $\eta: \text{Id}_{\mathcal{C}} \rightarrow UF$ and counit $\epsilon: FU \rightarrow \text{Id}_{\mathcal{D}}$. The endofunctor $UF: \mathcal{C} \rightarrow \mathcal{C}$ is a monad with multiplication and unit given by*

(5.13)

$\mu: UFUF \xrightarrow{U\epsilon_F} UF,$	$\eta: \text{Id}_{\mathcal{C}} \xrightarrow{\eta} UF.$

Let T be the monad of the adjunction $F: \mathcal{C} \rightleftarrows \mathcal{D} : U$. In the spirit of our previous remark, we might ask how much the functors F and U ‘differ’ from the free and forgetful functors $F_T: \mathcal{C} \rightarrow \mathcal{C}^T$ and $U_T: \mathcal{C}^T \rightarrow \mathcal{C}$ of T , respectively. Roughly summarised we are interested in the following:

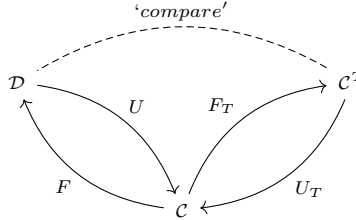

Definition 5.6. Let $T := UF$ be the monad of the adjunction $F: \mathcal{C} \rightleftarrows \mathcal{D} : U$. We refer to $\Sigma: \mathcal{D} \rightarrow \mathcal{C}^T$ as a *comparison functor* if

(5.14) $\Sigma F = F_T$ and $U_T \Sigma = U.$

Theorem 5.7. *Every monad T of an adjunction $F: \mathcal{C} \rightleftarrows \mathcal{D} : U$ admits a unique comparison functor $\Sigma: \mathcal{D} \rightarrow \mathcal{C}^T$. On objects it is given by*

(5.15) $\Sigma(X) = (U(X), U(\epsilon_X)),$ for all $X \in \mathcal{D}.$

We call an adjunction *monadic* if its comparison functor is an equivalence.

5.2. Bimonads and monoidal categories. Due to a lack of a (canonical) braiding on the endofunctors $\text{End}(\mathcal{C})$ over \mathcal{C} , the naïve notion of bialgebras does not generalise to the monadic setting and needs to be adjusted. One possible way of overcoming this problem was introduced and studied by Moerdijk under the name ‘Hopf monads’¹⁶ in [Moe02]; the idea being that the coherence morphisms of an oplax monoidal functor $(T, \Delta, \varepsilon): \mathcal{C} \rightarrow \mathcal{D}$, see Definition 2.2, serve as its ‘comultiplication’ and ‘counit’. Following the conventions of [BV07] we refer to such structures as bimonads.

Definition 5.8. A *bimonad* on a monoidal category \mathcal{C} is an oplax monoidal endofunctor $(B, \Delta, \varepsilon): \mathcal{C} \rightarrow \mathcal{C}$ together with oplax monoidal natural transformations $\mu: B^2 \rightarrow B$ and $\eta: \text{Id}_{\mathcal{C}} \rightarrow B$ implementing a monad structure on B .

A *morphism of bimonads* is a natural transformation $f: B \rightarrow H$ between bimonads which is oplax monoidal as well as a morphism of monads.

Convention. As discussed in Section 2.1, we refer to the coherence morphisms

$$\Delta: B(- \otimes -) \rightarrow B(-) \otimes B(-) \quad \text{and} \quad \varepsilon: B(1) \rightarrow 1$$

of a bimonad $(B, \mu, \eta, \Delta, \varepsilon): \mathcal{C} \rightarrow \mathcal{C}$ as its *comultiplication* and *counit*. Their defining relations, see Equations (2.4) and (2.5), will be called the *coassociativity* and *counitality axiom* of the comultiplication.

Remark 5.9. Despite this terminology not being standard, it can be justified by representation theoretic considerations. Under *Tannaka–Krein reconstruction*, see [EGNO15, Chapter 5], the comultiplication and counit of a bialgebra correspond to a tensor product and unit on its category of modules. Similarly, given a bimonad $(B, \mu, \eta, \Delta, \varepsilon): \mathcal{C} \rightarrow \mathcal{C}$ and two modules $(M, \vartheta_M), (N, \vartheta_N) \in \mathcal{C}^B$ we set

$$(5.16) \quad (M, \vartheta_M) \otimes (N, \vartheta_N) := (M \otimes N, (\vartheta_M \otimes \vartheta_N)\Delta_{M,N}).$$

Moreover, we define $\vartheta_1: B(1) \rightarrow 1$. The coassociativity and counitality of the comultiplication of B imply that the above construction implements a monoidal structure on \mathcal{C}^B , parallel to that on the modules over a bialgebra.

Going further, we can incorporate rigidity into this picture. In view of [BV07, Theorem 3.8], we state:

Definition 5.10. A bimonad $H: \mathcal{C} \rightarrow \mathcal{C}$ on a rigid category \mathcal{C} is called a *Hopf monad* if its category of modules \mathcal{C}^H is rigid.

Remark 5.11. The rigidity of the modules \mathcal{C}^H of a Hopf monad $H: \mathcal{C} \rightarrow \mathcal{C}$ is reflected by the existence of two natural transformations

$$(5.17) \quad s_X^l: H(H(X)^\vee) \rightarrow H^\vee, \quad s_X^r: H({}^\vee H(X)) \rightarrow {}^\vee H, \quad \text{for all } X \in \mathcal{C},$$

called the *left* and *right antipode* of H . In Example 2.4 of [BV12] it is explained how these generalise the antipode of a Hopf algebra.

The intricate interplay between monads and adjunctions transcends to monoidal categories and bimonads. Suppose $F: \mathcal{C} \rightleftarrows \mathcal{D} : U$ to be an oplax monoidal adjunction between \mathcal{C} and \mathcal{D} . The monad of the adjunction $UF: \mathcal{C} \rightarrow \mathcal{C}$ is a bimonad whose comultiplication is defined for every $X, Y \in \mathcal{C}$ as the composition

$$(5.18) \quad UF(X \otimes Y) \xrightarrow{U(\Delta_{X,Y}^{(F)})} U(F(X) \otimes F(Y)) \xrightarrow{\Delta_{F(X), F(Y)}^{(U)}} UF(X) \otimes UF(Y).$$

¹⁶As remarked in [Moe02], the concept of Hopf monads is strictly dual to that of monoidal comonads, which are studied for example in [Boa95].

Its counit is

$$(5.19) \quad UF(1) \xrightarrow{U(\varepsilon^{(F)})} U(1) \xrightarrow{\varepsilon^{(U)}} 1.$$

The next result is a slightly simplified version of [TV17, Lemma 7.10].

Lemma 5.12. *Let $F: \mathcal{C} \rightleftarrows \mathcal{D} : U$ be a pair of adjoint functors between two monoidal categories. The adjunction $F \dashv U$ is monoidal if and only if U is a strong monoidal functor. That is, the coherence morphisms of U are invertible.*

Suppose $B: \mathcal{C} \rightarrow \mathcal{C}$ to be the bimonad arising from the monoidal adjunction $F: \mathcal{C} \rightleftarrows \mathcal{D} : U$. Since the forgetful functor $U_B: \mathcal{C}^B \rightarrow \mathcal{C}$ is strict monoidal, the adjunction $F_B \dashv U_B$ is monoidal by the above lemma. This raises the question whether the comparison functor, mediating between the two adjunctions, is compatible with this additional structure. Due to [BV07, Theorem 2.6], we have the following result.

Lemma 5.13. *Let $F: \mathcal{C} \rightleftarrows \mathcal{D} : U$ be a monoidal adjunction and write $B: \mathcal{C} \rightarrow \mathcal{C}$ for its induced bimonad. The comparison functor $\Sigma: \mathcal{D} \rightarrow \mathcal{C}^B$ is strong monoidal and $U_B \Sigma = U$ as well as $\Sigma F = F_B$ as strong, respectively, oplax monoidal functors.*

The question to which extend the monoidal structure on \mathcal{C}^B is unique was answered by Moerdijk in [Moe02, Theorem 7.1].

Theorem 5.14. *Let (B, μ, η) be a monad on a monoidal category \mathcal{C} . There exists a one-to-one correspondence between bimonad structures on B and monoidal structures on \mathcal{C}^B such that the forgetful functor U_B is strict monoidal.*

5.3. The graphical calculus for bimonads. Willerton introduced a graphical calculus for bimonads in [Wil08]. Since it will aid us in making our arguments more transparent, we recall it here. The key idea is to incorporate the Cartesian product of categories into the string diagrammatic representation of functors and natural transformations.

As before, we consider strings and vertices between them. These are labelled with functors and natural transformations, respectively. The strings and vertices are embedded into bounded rectangles which we will call sheets. Each (connected) region of a sheet is decorated with a category. The same mechanics as for string diagrams apply—horizontal and vertical gluing represents composition of functors and natural transformations. On top of these operations, we add stacking sheets behind each other to depict the Cartesian product of categories. Our convention is to read diagrams from front to back, left to right and top to bottom.

Two of the most vital building blocks in this new graphical language are the tensor product and unit of a monoidal category $(\mathcal{C}, \otimes, 1)$:

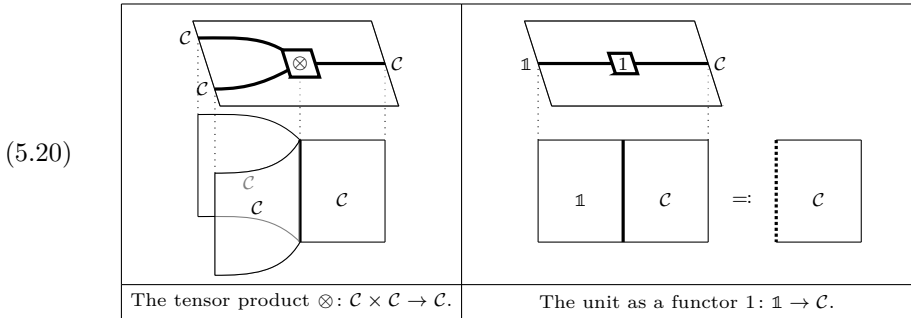

On the left, we see two sheets equating to two copies of \mathcal{C} joined by a line: the tensor product of \mathcal{C} . On the right, we have the unit of \mathcal{C} considered as a functor $\mathbb{1} \xrightarrow{1} \mathcal{C}$, where $\mathbb{1}$ is the category with one object and one morphism. Our convention is to represent the category $\mathbb{1}$ by the empty sheet and the unit of \mathcal{C} by a dashed line.

The first example we want to discuss is that of a bimonad $(B, \mu, \eta, \Delta, \varepsilon): \mathcal{C} \rightarrow \mathcal{C}$. Diagram (5.4) describes its unit and multiplication. The comultiplication and counit of B are represented by

(5.21)

$\Delta: B(- \otimes -) \rightarrow B(-) \otimes B(-), \quad \varepsilon: B(1) \rightarrow 1.$

In string diagrams, coassociativity and counitality equate to

(5.22)

$(\text{id}_B \otimes \Delta_{-, -}) \Delta_{-, - \otimes -} = (\Delta_{-, -} \otimes \text{id}_B) \Delta_{- \otimes -, -},$

(5.23)

$(\text{id} \otimes \varepsilon) \Delta_{-, 1} = \text{id}_B, \quad (\varepsilon \otimes \text{id}) \Delta_{1, -} = \text{id}_B.$

The multiplication and unit of B are comultiplicative and counital. The graphical version of these axioms is

(5.24)

$\Delta_{-, -} \mu_{- \otimes -} = (\mu_{-} \otimes \mu_{-}) \Delta_{B(-), B(-)} B(\Delta_{-, -}), \quad \Delta_{-, -} \eta_{- \otimes -} = \eta_{-} \otimes \eta_{-},$

(5.25)

$\varepsilon\mu_1 = \varepsilon B(\varepsilon),$	$\varepsilon\eta_1 = \text{id}_1.$

The second—equally important—example is that of an oplax monoidal adjunction $F: \mathcal{C} \rightleftarrows \mathcal{D} : U$. It is characterised by its unit $\eta^{(F \dashv U)}$ and counit $\varepsilon^{(F \dashv U)}$ being oplax monoidal natural transformations:

(5.26)

$\Delta_{F(-), F(-)}^{(U)} U(\Delta_{-, -}^{(F)}) \eta_{- \otimes -}^{(F \dashv U)} = \eta_{-}^{(F \dashv U)} \otimes \eta_{-}^{(F \dashv U)},$	$\varepsilon^{(U)} \varepsilon^{(F)} \eta_1^{(F \dashv U)} = \text{id}_1,$

(5.27)

$\varepsilon_{- \otimes -}^{(F \dashv U)} = (\varepsilon_{-}^{(F \dashv U)} \otimes \varepsilon_{-}^{(F \dashv U)}) \Delta_{U(-), U(-)}^{(F)} F(\Delta_{-, -}^{(U)}),$	$\varepsilon_1^{(F \dashv U)} = \varepsilon^{(F)} F(\varepsilon^{(U)}).$

5.4. Comodule monads. Monads with a ‘coaction’ over a bimonad were defined and studied by Aguiar and Chase in [AC12]. This concept is needed to obtain an adequate monadic interpretation of twisted centres. We briefly summarise the aspects of the aforementioned article that are needed for our investigation¹⁷. To keep our notation concise, we fix two monoidal categories \mathcal{C} and \mathcal{D} and over each a right module category \mathcal{M} and \mathcal{N} .

Definition 5.15. Suppose $(F, \Delta, \varepsilon): \mathcal{C} \rightarrow \mathcal{D}$ to be an oplax monoidal functor. A (right) comodule functor over F is a pair (G, δ) consisting of a functor $G: \mathcal{M} \rightarrow \mathcal{N}$ together with a natural transformation

$$(5.28) \quad \delta_{M, X}: G(M \triangleleft X) \rightarrow G(M) \triangleleft F(X), \quad \text{for all } X \in \mathcal{C} \text{ and } M \in \mathcal{M},$$

called the *coaction* of G , which is *coassociative* and *counital*. That is, for all $X, Y \in \mathcal{C}$ and $M \in \mathcal{M}$ we have

$$(5.29) \quad (\text{id}_{G(M)} \triangleleft \Delta_{X, Y}) \delta_{M, X \otimes Y} = (\delta_{M, X} \triangleleft \text{id}_{F(Y)}) \delta_{M \triangleleft X, Y},$$

$$(5.30) \quad (\text{id}_{G(M)} \triangleleft \varepsilon) \delta_{M, 1} = \text{id}_{G(M)}.$$

A comodule functor is called *strong* if its coaction is an isomorphism.

¹⁷We slightly deviate from [AC12] in that we study right comodule monads as opposed to their left versions.

A recurring example of strong comodule functors in our investigation is given by forgetful functors. By construction $U^{(Z)}: \mathbf{Z}(\mathcal{C}) \rightarrow \mathcal{C}$ is strict monoidal. Over it, the forgetful functor $U^{(L)}: \mathbf{Z}(\mathcal{L}\mathcal{C}) \rightarrow \mathcal{C}$ from a left twisted centre to its base category is strict comodule.

In order to emphasise that $(G, \delta): \mathcal{M} \rightarrow \mathcal{N}$ is a comodule functor over an oplax monoidal functor $(F, \Delta, \varepsilon): \mathcal{C} \rightarrow \mathcal{D}$, we colour it blue in our string diagrams. For example, its coaction is represented by

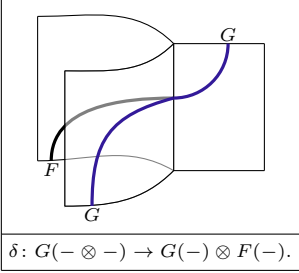
(5.31) 

$$\delta: G(- \otimes -) \rightarrow G(-) \otimes F(-).$$

The compatibility of the coaction with the comultiplication and counit of F given in Equations (5.29) and (5.30) would result in analogues of the Diagrams (5.22) and (5.23).

Definition 5.16. Let $G, K: \mathcal{M} \rightarrow \mathcal{N}$ be comodule functors over $B, F: \mathcal{C} \rightarrow \mathcal{D}$. A *comodule natural transformation* from G to K is a pair of natural transformations $\phi: G \rightarrow K$ and $\psi: B \rightarrow F$ such that

$$(5.32) \quad (\phi_M \triangleleft \psi_X) \delta_{M, X}^{(G)} = \delta_{M, X}^{(K)} \phi_{M \triangleleft X}, \quad \text{for all } X \in \mathcal{C} \text{ and } M \in \mathcal{M}.$$

We call (ϕ, ψ) a *morphism of comodule functors* if $B = F$ and $\psi = \text{id}_B$.

Suppose the pair $\phi: G \rightarrow K$ and $\psi: B \rightarrow F$ to constitute a comodule natural transformation. We can view $\phi: G \rightarrow K$ as a morphism of comodule functors over F if we equip G with a new coaction. It is given for all $X \in \mathcal{C}$ and $M \in \mathcal{M}$ by

$$G(M \triangleleft X) \xrightarrow{\delta_{M, X}^{(G)}} G(M) \triangleleft B(X) \xrightarrow{\text{id}_{G(M)} \triangleleft \psi_X} G(M) \triangleleft F(X).$$

It follows that by altering the involved coactions suitably, comodule natural transformations and morphisms of comodule functors can be identified with each other.

The graphical representation of the condition for $\phi: G \rightarrow K$ to be a morphism of comodule functors is displayed in our next diagram.

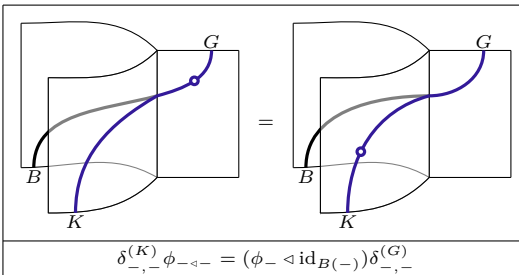
(5.33) 

$$\delta_{-, -}^{(K)} \phi_{- \triangleleft -} = (\phi_{-} \triangleleft \text{id}_{B(-)}) \delta_{-, -}^{(G)}$$

Remark 5.17. Let $(B, \mu, \eta, \Delta, \varepsilon): \mathcal{C} \rightarrow \mathcal{C}$ be a bimonad and \mathcal{M} a module category over \mathcal{C} . The unit $\eta: \text{Id}_{\mathcal{C}} \rightarrow B$ implements a coaction on $\text{Id}_{\mathcal{M}}: \mathcal{M} \rightarrow \mathcal{M}$ via

$$(5.34) \quad \text{id}_{\mathcal{M}} \triangleleft \eta_X: \text{Id}_{\mathcal{M}}(M \triangleleft X) \rightarrow \text{Id}_{\mathcal{M}}(M) \triangleleft B(X), \quad \text{for all } X \in \mathcal{C}, M \in \mathcal{M}.$$

Using the multiplication $\mu: B^2 \rightarrow B$, we can equip the composition GK of two comodule functors $G, K: \mathcal{M} \rightarrow \mathcal{M}$ with a comodule structure:

$$(5.35) \quad \delta^{(GK)} := (\text{id} \triangleleft \mu) \delta^{(K)} G(\delta^{(K)}): GK(- \triangleleft -) \rightarrow GK(-) \triangleleft B(-).$$

Due to the associativity and unitality of the multiplication of B , the category $\text{Com}(B, \mathcal{M})$ of comodule endofunctors on \mathcal{M} over B is monoidal. Studying its monoids will be a main focus of the rest of this section.

Definition 5.18. Consider a bimonad $B: \mathcal{C} \rightarrow \mathcal{C}$ and a module category \mathcal{M} over \mathcal{C} . A *comodule monad* over B on \mathcal{M} is a comodule endofunctor $(K, \delta): \mathcal{M} \rightarrow \mathcal{M}$ together with morphisms of comodule functors $\mu: K^2 \rightarrow K$ and $\eta: \text{Id}_{\mathcal{M}} \rightarrow K$ such that (K, μ, η) is a monad.

A *morphism of comodule monads* is a natural transformation of comodule functors $f: K \rightarrow L$ that is also a morphism of monads.

The conditions for the multiplication and unit of a comodule monad $K: \mathcal{M} \rightarrow \mathcal{M}$ over a bimonad $B: \mathcal{C} \rightarrow \mathcal{C}$ to be morphisms of comodule functors amount to

$$(5.36) \quad \begin{array}{c} \begin{array}{ccc} \begin{array}{c} \text{Diagram 1: } \delta_{-, -} \mu_{-, -}^{(K)} \\ \text{Diagram 2: } (\mu_{-, -}^{(K)} \triangleleft \mu_{-, -}^{(B)}) \delta_{K(-), B(-)} K(\delta_{-, -}) \\ \text{Diagram 3: } \delta_{-, -} \eta_{-, -}^{(K)} \\ \text{Diagram 4: } (\eta_{-, -}^{(K)} \triangleleft \eta_{-, -}^{(B)}) \end{array} \\ \hline \delta_{-, -} \mu_{-, -}^{(K)} = (\mu_{-, -}^{(K)} \triangleleft \mu_{-, -}^{(B)}) \delta_{K(-), B(-)} K(\delta_{-, -}), \quad \delta_{-, -} \eta_{-, -}^{(K)} = \eta_{-, -}^{(K)} \triangleleft \eta_{-, -}^{(B)}. \end{array} \end{array}$$

Remark 5.19. Let $B: \mathcal{C} \rightarrow \mathcal{C}$ be a bimonad and $(K, \delta): \mathcal{M} \rightarrow \mathcal{M}$ a comodule monad over it. The coaction of K allows us to define an action $\triangleleft: \mathcal{M}^K \times \mathcal{C}^B \rightarrow \mathcal{M}^K$. For any two modules $(M, \vartheta_M) \in \mathcal{M}^K$ and $(X, \vartheta_X) \in \mathcal{C}^B$, it is given by

$$(5.37) \quad (M, \vartheta_M) \triangleleft (X, \vartheta_X) := (M \triangleleft X, (\vartheta_M \triangleleft \vartheta_X) \delta_{M, X}).$$

The axioms of the coaction of B on K translate precisely to the compatibility of the action of \mathcal{C}^B on \mathcal{M}^K with the tensor product and unit of \mathcal{C}^B .

We have already seen that monads and adjunctions are in close correspondence and that additional structures on the monads have their counterparts expressed in terms of the units and counits of adjunctions. In the case of comodule monads this is slightly more complicated as we have two adjunctions to consider: one corresponding to the bimonad and one to the comodule monad.

Definition 5.20. Consider two adjunctions $F: \mathcal{C} \rightleftarrows \mathcal{D}: U$ and $G: \mathcal{M} \rightleftarrows \mathcal{N}: V$ such that $F \dashv U$ is monoidal and G, V are comodule functors over F, U . We call the pair $(G \dashv V, F \dashv U)$ a *comodule adjunction* if the following two identities hold:

$$(5.38) \quad \begin{array}{c} \begin{array}{ccc} \text{Diagram 1: } \delta_{G(-), F(-)}^{(V)} V(\delta_{-, -}^{(G)}) \eta_{-, -}^{(G \dashv V)} \\ \text{Diagram 2: } \eta_{-, -}^{(G \dashv V)} \triangleleft \eta_{-, -}^{(F \dashv U)} \end{array} \\ \hline \delta_{G(-), F(-)}^{(V)} V(\delta_{-, -}^{(G)}) \eta_{-, -}^{(G \dashv V)} = \eta_{-, -}^{(G \dashv V)} \triangleleft \eta_{-, -}^{(F \dashv U)}, \end{array}$$

(5.39)

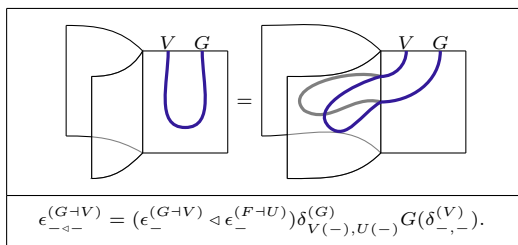

$$\epsilon_{-\triangleleft-}^{(G \dashv V)} = (\epsilon_{-}^{(G \dashv V)} \triangleleft \epsilon_{-}^{(F \dashv U)}) \delta_{V(-), U(-)}^{(G)} G(\delta_{-, -}^{(V)}).$$

The philosophy that monads and adjunctions are two sides of the same coin extends to the comodule setting. Suppose that we have a monoidal adjunction $F: \mathcal{C} \rightleftarrows \mathcal{D} : U$ and over it a comodule adjunction $G: \mathcal{M} \rightleftarrows \mathcal{N} : V$. As stated in [AC12, Proposition 4.3.1], the bimonad $B := UF$ admits a coaction on the monad $K := VG$. For any $M \in \mathcal{M}$ and $X \in \mathcal{C}$ it is given by

(5.40)

$$VG(M \triangleleft X) \xrightarrow{V(\delta_{M, X}^{(G)})} V(G(M) \triangleleft F(X)) \xrightarrow{\delta_{G(M), F(X)}^{(V)}} K(M) \triangleleft B(X).$$

The next result slightly extends Proposition 4.1.2 of [AC12]. We prove it analogous to [TV17, Lemma 7.10].

Theorem 5.21. *Suppose $F: \mathcal{C} \rightleftarrows \mathcal{D} : U$ to be a monoidal adjunction and let $G: \mathcal{M} \rightleftarrows \mathcal{N} : V$ be an adjunction between module categories over \mathcal{C} and \mathcal{D} , respectively. Lifts of $G \dashv V$ to a comodule adjunction are in bijection with lifts of $V: \mathcal{N} \rightarrow \mathcal{M}$ to a strong comodule functor.*

Proof. Let $G \dashv V$ be a comodule adjunction and write $\delta^{(V)}$ for the coaction of V . We define its inverse via

(5.41)

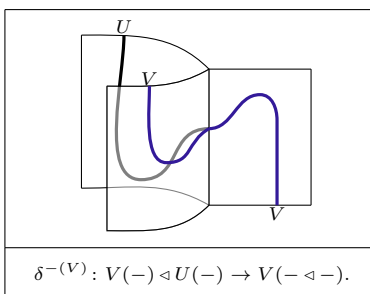

$$\delta^{-(V)}: V(-) \triangleleft U(-) \rightarrow V(- \triangleleft -).$$

Using that G and H are part of a comodule adjunction, we compute:

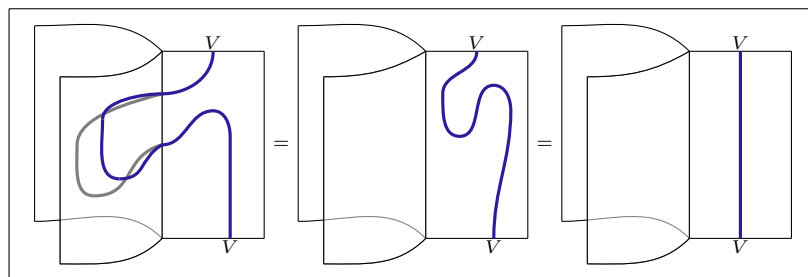

A similar strategy can be used to show that $\delta_{N, Y}^{(V)} \circ \delta_{N, Y}^{-(V)} = \text{id}_{V(N) \triangleleft U(Y)}$ for all $Y \in \mathcal{D}$ and $N \in \mathcal{N}$. Thus, $\delta^{(V)}$ is a natural isomorphism and therefore V is a strong comodule functor.

It follows that the unit of the adjunction $G \dashv H$ satisfies:

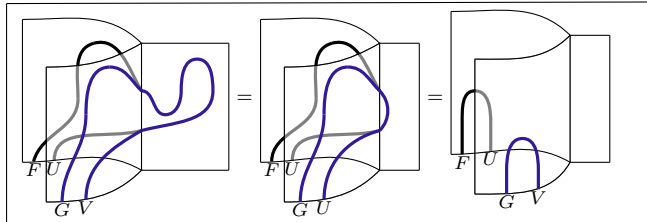

An analogous computation for the counit shows that $G \dashv V$ is a comodule adjunction.

To see that these constructions are inverse to each other, first suppose that we have a comodule adjunction $(G, \delta^{(G)}) \dashv (V, \delta^{(V)})$. By utilising $\delta^{-(V)}$ as given in Diagram (5.41), we obtain another coaction $\lambda^{(G)}$ on G , see Diagram (5.42). A direct computation shows that $\delta^{(G)} = \lambda^{(G)}$:

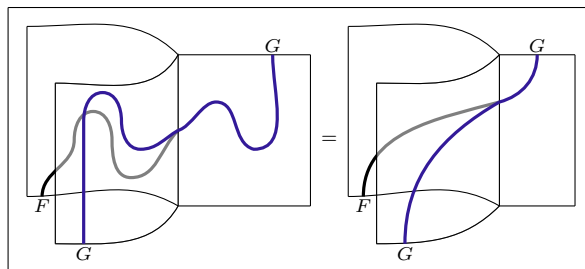

The converse direction is clear since inverses of natural isomorphisms are unique. \square

The above theorem yields a description of the coaction of a comodule monad in terms of its Eilenberg–Moore adjunction. It is an analogue of Theorem 5.14.

Corollary 5.22. *Let $B: \mathcal{C} \rightarrow \mathcal{C}$ be a bimonad and \mathcal{M} a right module over \mathcal{C} . Further suppose $K: \mathcal{M} \rightarrow \mathcal{M}$ to be a monad. Coactions of B on K are in bijection with right actions of \mathcal{C}^B on \mathcal{M}^K such that U_K is a strict comodule functor over U_B .*

Proof. Suppose \mathcal{C}^B acts from the right on \mathcal{M}^K such that U_K is a strict comodule functor. Due to Theorem 5.21, $K = U_K F_K$ is a comodule monad via the coaction

$$(5.45) \quad \delta^{(K)} = \delta^{(U_K)} U_K (\delta^{(F_K)}) = U_K (\delta^{(F_K)}).$$

Conversely, if K is a comodule monad, \mathcal{M}^K becomes a suitable right module over \mathcal{C}^B with the action as given in Remark 5.19.

Since the coaction on K and the action of \mathcal{C}^B on \mathcal{M}^K determine the coactions of F_K uniquely, the above constructions are inverse to each other by Theorem 5.21. \square

The next result clarifies the structure of comparison functors associated to comodule adjunctions. We prove it analogous to [BV07, Theorem 2.6].

Lemma 5.23. *Consider a comodule adjunction $G: \mathcal{M} \rightleftarrows \mathcal{N}: V$ over a monoidal adjunction $F: \mathcal{C} \rightleftarrows \mathcal{D}: U$ and denote the associated comodule monad and bimonad by $K = VG: \mathcal{M} \rightarrow \mathcal{M}$ and $B = UF: \mathcal{C} \rightarrow \mathcal{C}$, respectively. The comparison functor $\Sigma^{(K)}: \mathcal{N} \rightarrow \mathcal{M}^K$ is a strong comodule functor over $\Sigma^{(B)}: \mathcal{D} \rightarrow \mathcal{C}^B$ and $U_K \Sigma^{(K)} = V$, as well as $\Sigma^{(K)} G = F_K$ as comodule functors.*

Proof. For any $N \in \mathcal{N}$ we have $\Sigma^{(K)}(N) = (V(N), V(\epsilon_N))$ and a direct computation shows that the coaction of V lifts to a coaction of $\Sigma^{(K)}$. That is, we have

$$U_K \left(\delta_{N,Y}^{\Sigma^{(K)}} \right) = \delta_{N,Y}^V, \quad \text{for all } N \in \mathcal{N} \text{ and } Y \in \mathcal{D}.$$

Using that $U_K: \mathcal{M}^K \rightarrow \mathcal{M}$ is a faithful and conservative functor, we observe that $\Sigma^{(K)}$ becomes a strong comodule functor in this manner. Furthermore, as U_K is strict comodule, the coactions of $U_K \Sigma^{(K)}$ and V coincide. Lastly, we compute for any $X \in \mathcal{C}$ and $M \in \mathcal{M}$

$$\delta_{M,X}^{(\Sigma^{(K)}G)} = \delta_{M,X}^{(U_K \Sigma^{(K)}G)} = \delta_{M,X}^{(VG)} = \delta_{M,X}^{(K)} = \delta_{M,X}^{(U_K F_K)} = \delta_{M,X}^{(F_K)}.$$

□

5.5. Cross products and distributive laws. Suppose \mathcal{C} to be the modules of a Hopf monad $H: \mathcal{V} \rightarrow \mathcal{V}$. The Hopf monadic description of the Drinfeld centre $Z(\mathcal{C})$ of \mathcal{C} due to Bruguières and Virelizier, given in [BV12], is achieved as a two-step process. First, by finding a suitable monad on \mathcal{C} and then ‘extending’ it to a monad on \mathcal{V} . We will review this ‘extension’ process based on Sections 3 and 4 of [BV12].

Definition 5.24. Let $H: \mathcal{V} \rightarrow \mathcal{V}$ and $T: \mathcal{V}^H \rightarrow \mathcal{V}^H$ be two monads. The *cross product* $T \rtimes H$ of T by H is the monad $U_H T F_H: \mathcal{V} \rightarrow \mathcal{V}$ whose multiplication and unit are given by

$$(5.46) \quad \begin{array}{|c|c|} \hline \begin{array}{c} \text{Diagram 1: A box with two input wires at the bottom labeled } F_H T U_H \text{ and two output wires at the top labeled } F_H T U_H. The wires cross and then merge into two.} \\ F_H T U_H \end{array} & \begin{array}{c} \text{Diagram 2: A box with two input wires at the bottom labeled } F_H T U_H \text{ and two output wires at the top labeled } F_H T U_H. The wires merge into one, then split into two.} \\ F_H T U_H \end{array} \\ \hline U_H(\mu_{F_H}^{(T)})U_H T(\epsilon_{T F_H}^{(F \dashv U)}), & U_H(\eta_{F_H}^{(T)})\eta^{(F \dashv U)}. \end{array}$$

The cross product $B \rtimes H: \mathcal{C} \rightarrow \mathcal{C}$ of two bimonads $H: \mathcal{V} \rightarrow \mathcal{V}$ and $B: \mathcal{V}^H \rightarrow \mathcal{V}^H$ is a bimonad again, with comultiplication and counit

$$(5.47) \quad \begin{array}{|c|c|} \hline \begin{array}{c} \text{Diagram 1: A box with two input wires at the bottom labeled } F_H B U_H \text{ and two output wires at the top labeled } F_H B U_H. The wires are curved and cross.} \\ F_H B U_H \end{array} & \begin{array}{c} \text{Diagram 2: A box with two input wires at the bottom labeled } F_H B U_H \text{ and two output wires at the top labeled } F_H B U_H. The wires are curved and do not cross.} \\ F_H B U_H \end{array} \\ \hline \Delta_{B F_H(-), B F_H(-)}^{(U_H)} U_H(\Delta_{F_H(-), F_H(-)}^{(B)}) U_H B(\Delta_{-, -}^{(F_H)}), & \epsilon^{(U_H)} U_H(\epsilon^{(B)}) U_H B(\epsilon^{(F_H)}). \end{array}$$

The comultiplicativity and counitality of the multiplication and unit of $B \rtimes H$ can be deduced from Diagrams (5.24), (5.25), (5.26) and (5.27). Similar considerations imply the following:

Lemma 5.25. *Let $H: \mathcal{V} \rightarrow \mathcal{V}$ and $B: \mathcal{V}^H \rightarrow \mathcal{V}^H$ be bimonads which respectively coact on the comodule monads $K: \mathcal{M} \rightarrow \mathcal{M}$ and $C: \mathcal{M}^K \rightarrow \mathcal{M}^K$. The cross product*

$C \times K: \mathcal{M} \rightarrow \mathcal{M}$ is a comodule monad over $B \times H$ via the coaction

(5.48)

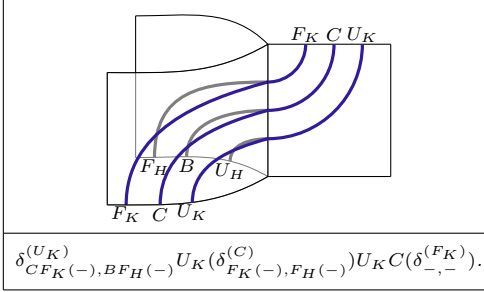

$$\delta_{CF_K(-), BF_H(-)}^{(U_K)} U_K(\delta_{F_K(-), F_H(-)}^{(C)}) U_K C(\delta_{-, -}^{(F_K)}).$$

Assume we have a monad $B: \mathcal{V}^H \rightarrow \mathcal{V}^H$ ‘on top’ of another monad $H: \mathcal{V} \rightarrow \mathcal{V}$. The question under which conditions the modules $\mathcal{V}^{B \times H}$ of $B \times H$ are isomorphic to $(\mathcal{V}^H)^B$ is closely related to Beck’s theory of distributive laws, developed in [Bec69].

Definition 5.26. Consider two monads $(H, \mu^{(H)}, \eta^{(H)})$, $(T, \mu^{(T)}, \eta^{(T)}): \mathcal{V} \rightarrow \mathcal{V}$. A *distributive law* of T over H is a natural transformation

(5.49)
$$\Omega: HT \rightarrow TH,$$

subject to the following relations:

(5.50)

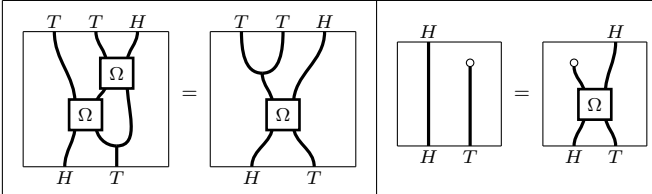

$$\mu_H^{(T)} T(\Omega) \Omega_T = \Omega H \mu^{(T)}, \quad \eta_H^{(T)} = \Omega H \eta^{(T)},$$

(5.51)

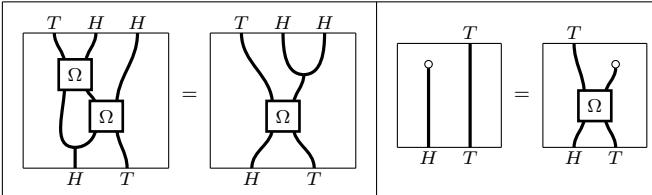

$$T(\mu^{(H)}) \Omega_H H(\Omega) = \Omega \mu_T^{(H)}, \quad T(\eta^{(H)}) = \Omega \eta_T^{(H)}.$$

A distributive law $\Omega: HT \rightarrow TH$ between $H, T: \mathcal{V} \rightarrow \mathcal{V}$ allows us to define a new monad $T \circ_{\Omega} H: \mathcal{V} \rightarrow \mathcal{V}$. Its underlying functor is $TH: \mathcal{V} \rightarrow \mathcal{V}$ and its multiplication and unit are given by:

(5.52)

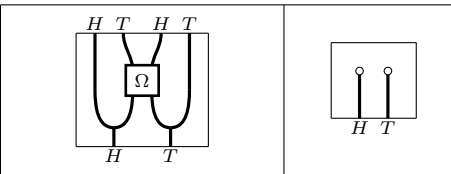

$$\mu := \mu_H^{(T)} T^2(\mu^{(H)}) T(\Omega_H) \quad \eta := \eta_H^{(T)} \eta^{(H)}$$

Street developed the theory of monads and distributive laws intrinsic to ‘well-behaved’ 2-categories in [Str72]. If we apply his findings to the 2-category $\otimes\text{-Cat}$ of monoidal categories, oplax monoidal functors and oplax monoidal natural transformations, we obtain a description of bimonads and *oplax monoidal distributive laws*, see also [McC02]. That is, oplax monoidal natural transformations $\Lambda: HB \rightarrow BH$ between bimonads $H, B: \mathcal{V} \rightarrow \mathcal{V}$ that are moreover distributive laws in the sense of Definition 5.26. Accordingly, suppose $\Lambda: HB \rightarrow BH$ to be an oplax monoidal distributive law. The comultiplication and counit of the underlying functor $BH: \mathcal{V} \rightarrow \mathcal{V}$ turn $B \circ_{\Lambda} H$ into a bimonad.

Comodule monads, on the other hand, can be intrinsically described in the 2-category $(\triangleleft\text{-Cat}, \otimes\text{-Cat})$ which has

- (i) as objects pairs $(\mathcal{M}, \mathcal{V})$ comprising a right module category \mathcal{M} over a monoidal category \mathcal{V} ,
- (ii) as 1-morphisms pairs (G, F) of a comodule functor G over an oplax monoidal functor F , and
- (iii) as 2-morphisms pairs (ϕ, ψ) which constitute a comodule natural transformation.

The subsequent definition and results arise immediately from [Str72].

Definition 5.27. Let $K, C: \mathcal{M} \rightarrow \mathcal{M}$ be two comodule monads over the bimonads $H, B: \mathcal{V} \rightarrow \mathcal{V}$, respectively. A *comodule distributive law* is a pair of distributive laws $\Omega: KC \rightarrow CK$ and $\Lambda: HB \rightarrow BH$ such that (Ω, Λ) is a comodule natural transformation.

Definition 5.28. Let $T: \mathcal{C} \rightarrow \mathcal{C}$ be a monad and $U: \mathcal{D} \rightarrow \mathcal{C}$ a functor. We call a monad $\tilde{T}: \mathcal{D} \rightarrow \mathcal{D}$ a *lift* of T if $U\tilde{T} = TU$ and for all $X \in \mathcal{D}$

$$(5.53) \quad U(\mu_X^{(\tilde{T})}) = \mu_{U(X)}^{(T)} \quad \text{and} \quad U(\eta_X^{(\tilde{T})}) = \eta_X^{(T)}.$$

As the next result shows, distributive laws are closely related to lifts of monads.

Theorem 5.29. Consider two comodule monads $K, C: \mathcal{M} \rightarrow \mathcal{M}$ over the bimonads $H, B: \mathcal{V} \rightarrow \mathcal{V}$. There exists a bijective correspondence between:

- (i) comodule distributive laws $(KC \xrightarrow{\Omega} CK, HB \xrightarrow{\Lambda} BH)$, and
- (ii) lifts of B to a bimonad $\tilde{B}: \mathcal{V}^H \rightarrow \mathcal{V}^H$ together with lifts of C to a comodule monad $\tilde{C}: \mathcal{M}^K \rightarrow \mathcal{M}^K$ over \tilde{B} such that $BU_H = U_H\tilde{B}$ as oplax monoidal functors and $CU_K = U_K\tilde{C}$ as comodule functors.

Let $(KC \xrightarrow{\Omega} CK, HB \xrightarrow{\Lambda} BH)$ be a comodule distributive law. The coactions of K and C turn $C \circ_{\Omega} K$ into a comodule monad over $B \circ_{\Lambda} H$.

Lemma 5.30. Suppose $\Omega: KC \rightarrow CK$ and $\Lambda: HB \rightarrow BH$ to form a comodule distributive law, then

- (i) $(\mathcal{V}^H)^{\tilde{B}^{\Lambda}}$ is isomorphic as a monoidal category to $\mathcal{V}^{B \circ_{\Lambda} H}$, and
- (ii) $(\mathcal{M}^K)^{\tilde{C}^{\Omega}}$ is isomorphic as a module category over $\mathcal{V}^{B \circ_{\Lambda} H}$ to $\mathcal{M}^{C \circ_{\Omega} K}$.

Remark 5.31. Suppose $B, H: \mathcal{V} \rightarrow \mathcal{V}$ to be Hopf monads. In [BV12] it is shown that if $\Lambda: HB \rightarrow BH$ is a oplax monoidal distributive law, $B \circ_{\Lambda} H: \mathcal{V} \rightarrow \mathcal{V}$ and the lift $\tilde{B}^{\Lambda}: \mathcal{V}^H \rightarrow \mathcal{V}^H$ are Hopf monads, as well.

5.6. Coend calculus. For our subsequent monadic description of the anti-Drinfeld centre, we need to functorially associate to every object a ‘free object’, which carries enough information to equip it with a ‘universal’ half-braiding. A feasible way of achieving this is given by considering appropriate coends. Based on [Lor21], we give an overview of a simplified version of their theory, tailored to our needs.

Definition 5.32. Consider three categories $\mathcal{A}, \mathcal{B}, \mathcal{C}$. An *extranatural transformation* $\zeta: P \multimap Q$ from a functor $P: \mathcal{B}^{\text{op}} \times \mathcal{A} \times \mathcal{B} \rightarrow \mathcal{C}$ to a functor $Q: \mathcal{A} \rightarrow \mathcal{C}$ is a collection of natural transformations

$$\zeta_{B,-}: P(B, -, B) \rightarrow Q(-), \quad \text{for all } B \in \mathcal{B},$$

which satisfy for all $f \in \mathcal{B}(B, B')$ and $A \in \mathcal{A}$ the *cowedge condition*

$$(5.54) \quad \zeta_{B,A}P(f, \text{id}_A, \text{id}_B) = \zeta_{B',A}P(\text{id}_{B'}, \text{id}_A, f).$$

Remark 5.33. Our definition of an extranatural transformation $\zeta: P \multimap Q$ differs in two ways from the one given in the literature. First, we have chosen a different order for the source categories of the trivalent functor $P: \mathcal{B}^{\text{op}} \times \mathcal{A} \times \mathcal{B} \rightarrow \mathcal{C}$ then what is the norm. Second, in its full generality, the ‘target functor’ Q of $\zeta: P \multimap Q$ could be trivalent as well. That is, it could be of the form $Q: \mathcal{D}^{\text{op}} \times \mathcal{A} \times \mathcal{D} \rightarrow \mathcal{C}$, where \mathcal{D} is a category which is possibly distinct from \mathcal{A}, \mathcal{B} and \mathcal{C} .

Definition 5.34. Consider an extranatural transformation $\zeta: P \multimap Q$ from a functor $P: \mathcal{B}^{\text{op}} \times \mathcal{A} \times \mathcal{B} \rightarrow \mathcal{C}$ to a functor $Q: \mathcal{A} \rightarrow \mathcal{C}$. We call the pair (Q, ζ) *universal* if for every other extranatural transformation $\xi: P \multimap R$ from P to a functor $R: \mathcal{A} \rightarrow \mathcal{C}$ there exists a unique natural transformation $\nu: Q \rightarrow R$ such that for all $A \in \mathcal{A}$ and $f \in \mathcal{B}(B, B')$ the following diagram commutes:

$$(5.55) \quad \begin{array}{ccccc} & & & & \xi_{B',A} \\ & & & & \curvearrowright \\ & & & & R(A) \\ & & & \swarrow \exists! \nu_A & \\ & & & Q(A) & \xleftarrow{\zeta_{B',A}} P(B', A, B') \\ & & & \uparrow \zeta_{B,A} & \uparrow P(\text{id}_{B'}, \text{id}_A, f) \\ & & & P(B, A, B) & \xleftarrow{P(f, \text{id}_A, \text{id}_B)} P(B', A, B) \\ & & & \uparrow \zeta_{B,A} & \\ & & & R(A) & \end{array}$$

In this case, we call $Q(A)$ the *coend* of $P(-, A, -): \mathcal{B}^{\text{op}} \times \mathcal{B} \rightarrow \mathcal{C}$ for any $A \in \mathcal{A}$.

Remark 5.35. It follows from their definition that universal extranatural transformations are unique up to unique natural isomorphisms.

6. A MONADIC PERSPECTIVE ON TWISTED CENTRES

The anti-Yetter–Drinfeld modules of a finite-dimensional Hopf algebra are a module category over the Yetter–Drinfeld modules. Subsequently, they are implemented by a comodule algebra over the Drinfeld double, see [HKRS04a]. As explained in Section 4, we find ourselves in a similar situation. Our replacement of the anti-Yetter–Drinfeld modules, the anti-Drinfeld centre, is a module category over the Drinfeld centre.

We replace finite-dimensional vector spaces by a rigid, possibly pivotal, category \mathcal{V} and the underlying Hopf algebra with a Hopf monad $H: \mathcal{V} \rightarrow \mathcal{V}$. In this section we study a Hopf monad $D(H): \mathcal{V} \rightarrow \mathcal{V}$ and over it a comodule monad $Q(H): \mathcal{V} \rightarrow \mathcal{V}$,

which realise the centre and its twisted cousin as their respective modules. Bruguières and Virelizier gave a transparent description of $D(H)$ in [BV12] by extending results of Day and Street, see [DS07]. The key concept in its construction is the so-called centraliser of the identity functor of \mathcal{V}^H . It is used to define a Hopf monad $\mathfrak{D}(\mathcal{V}^H)$ on \mathcal{V}^H with $Z(\mathcal{V}^H)$ as its Eilenberg–Moore category. From this, one obtains—as an application of Beck’s theory of distributive laws—the Drinfeld double $D(H): \mathcal{V} \rightarrow \mathcal{V}$. We apply the same techniques to define the anti-double $Q(H)$ of H , whose modules are isomorphic to the ‘dual’ of the anti-Drinfeld centre $Q(\mathcal{V}^H)$. This approach is best summarised by the following diagram:

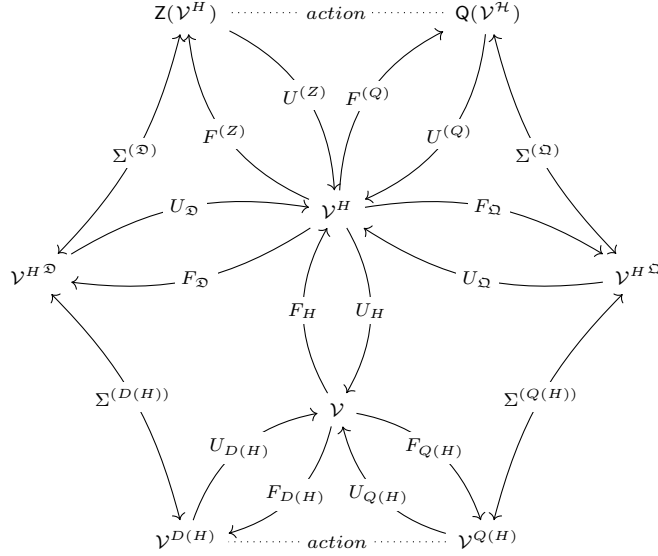

FIGURE 2. A cobweb of adjunctions, monads and various versions of the Drinfeld and anti-Drinfeld centre.

The translation of module functors between $Z(\mathcal{V}^H)$ and $Q(\mathcal{V}^H)$ into morphisms of comodule monads between $Q(H)$ and $D(H)$ yields our desired monadic version of Theorem 1.1, which we prove in Theorem 6.26. We end our endeavour into the theory of comodule monads with Corollary 6.27. In it, we explain how pivotal structures on \mathcal{V}^H arise from module morphisms between the so-called central Hopf monad \mathfrak{D} and the anti-central comodule monad \mathfrak{Q} .

6.1. Centralisable functors and the central bimonad. The construction of the double of a Hopf monad $H: \mathcal{V} \rightarrow \mathcal{V}$ given in [BV12] relies heavily on an ‘accessible’ left dual of the forgetful functor $U^{(Z)}: Z(\mathcal{V}^H) \rightarrow \mathcal{V}^H$. It is obtained as an application of the coend calculus covered in Section 5.6.

Definition 6.1. Suppose \mathcal{C} to be a rigid category and $T: \mathcal{C} \rightarrow \mathcal{C}$ to be an endofunctor. We call T *centralisable* if there exists a universal extranatural transformation

$$\zeta_{Y,X}: T(Y)^\vee \otimes X \otimes Y \rightarrow Z_T(X), \quad \text{for } X, Y \in \mathcal{C}.$$

A centralisable functor $T: \mathcal{C} \rightarrow \mathcal{C}$ admits a *universal coaction*

$$(6.1) \quad \chi_{X,Y} := (\text{id}_{T(Y)} \otimes \zeta_{Y,X})(\text{coev}_{T(Y)}^l \otimes \text{id}_Y), \quad \text{for } X, Y \in \mathcal{C},$$

which is natural in both variables. We call the pair (Z_T, χ) a *centraliser* of T .

Graphically, we represent the universal coaction as

$$(6.2) \quad \begin{array}{c} \begin{array}{c} X \quad Y \\ \diagdown \quad / \\ \bullet \\ / \quad \diagdown \\ T(Y) \quad Z_T(X) \end{array} \\ \hline \chi_{X,Y} : X \otimes Y \rightarrow T(Y) \otimes Z_T(X). \end{array}$$

It being natural equates to

$$(6.3) \quad \begin{array}{c} \begin{array}{c} V \quad X \\ \diagdown \quad / \\ \bullet \\ / \quad \diagdown \\ T(Y) \quad Z_T(W) \end{array} \quad \begin{array}{c} \boxed{f} \quad \boxed{g} \\ \diagdown \quad / \\ \bullet \\ / \quad \diagdown \\ T(Y) \quad Z_T(W) \end{array} = \begin{array}{c} V \quad X \\ \diagdown \quad / \\ \bullet \\ / \quad \diagdown \\ T(g) \quad Z_T(f) \\ \diagdown \quad / \\ T(Y) \quad Z_T(W) \end{array} \\ \hline \chi_{W,Y}(f \otimes g) = (T(g) \otimes Z_T(f))\chi_{V,X} \\ \text{for all morphisms } f: V \rightarrow W \text{ and } g: X \rightarrow Y. \end{array}$$

The *extended factorisation property* of universal coactions provides us with a potent tool for constructing bi- and comodule monads. Its proof is given for example in [BV12, Lemma 5.4].

Lemma 6.2. *Let (Z_T, χ) be the centraliser of a functor $T: \mathcal{C} \rightarrow \mathcal{C}$ and suppose that $L, R: \mathcal{D} \rightarrow \mathcal{C}$ are two functors. For any $n \in \mathbb{N}$ and any natural transformation*

$$\phi_{X, Y_1, \dots, Y_n}: L(X) \otimes Y_1 \otimes \dots \otimes Y_n \rightarrow T(Y_1) \otimes \dots \otimes T(Y_n) \otimes R(X),$$

where $X \in \mathcal{D}$ and $Y_1, \dots, Y_n \in \mathcal{C}$, there exists a unique natural transformation

$$\nu_V: Z_T^n L(X) \rightarrow R(X), \quad \text{for } V \in \mathcal{D},$$

which satisfies

$$(6.4) \quad \begin{array}{c} \begin{array}{c} L(X) \quad Y_1 \quad \dots \quad Y_n \\ \diagdown \quad / \quad \dots \quad / \\ \bullet \\ / \quad \diagdown \quad \dots \quad / \\ \boxed{\phi_{X, Y_1, \dots, Y_n}} \\ \diagdown \quad / \quad \dots \quad / \\ T(Y_1) \quad \dots \quad T(Y_n) \quad R(X) \end{array} = \begin{array}{c} L(X) \quad Y_1 \quad \dots \quad Y_n \\ \diagdown \quad / \quad \dots \quad / \\ \bullet \quad \dots \quad \bullet \\ / \quad \diagdown \quad \dots \quad / \\ T(Y_1) \quad \dots \quad T(Y_n) \quad \boxed{\nu_X} \\ \diagdown \quad / \\ T(Y_1) \quad \dots \quad T(Y_n) \quad R(X) \end{array} \\ \hline \phi_{X, Y_1, \dots, Y_n} = (\text{id} \otimes \nu_X) (\text{id} \otimes \chi_{Z_T^{n-1} L(X), Y_n}) \dots (\text{id} \otimes \chi_{Z_T L(X), Y_2} \otimes \text{id}) (\chi_{L(X), Y_1} \otimes \text{id}). \end{array}$$

Suppose $(T, \Delta^{(T)}, \varepsilon^{(T)}): \mathcal{C} \rightarrow \mathcal{C}$ to be an oplax monoidal functor with centraliser (Z_T, χ) . For all $X \in \mathcal{C}$, the counit of T combined with the universal coaction of Z_T gives rise to a natural transformation

$$(6.5) \quad \begin{array}{c} \begin{array}{c} X \quad \dots \quad 1 \\ \diagdown \quad / \quad \dots \quad / \\ \bullet \\ / \quad \diagdown \\ \boxed{\varepsilon^{(T)}} \\ \diagdown \quad / \\ \bullet \\ / \quad \diagdown \\ \cdot 1 \quad Z_T(X) \end{array} \\ \hline \eta_X^{(Z_T)} : X \rightarrow Z_T(X). \end{array}$$

We derive another natural transformation $\mu^{(Z_T)}: Z_T^2 \rightarrow Z_T$ from the comultiplication of T . Due to Lemma 6.2 it is uniquely defined by

$$(6.6) \quad \begin{array}{c} \begin{array}{ccc} X & & Y \otimes W \\ & \searrow & \nearrow \\ & \bullet & \\ & \nearrow & \searrow \\ T(Y) & & T(W) \\ \Delta^{(T)} \end{array} & = & \begin{array}{ccc} X & & Y & & W \\ & \searrow & \nearrow & & \\ & \bullet & & \bullet & \\ & \nearrow & & \nearrow & \searrow \\ T(Y) & & T(W) & & Z_T^2(X) \\ \mu_X^{(Z_T)} \end{array} \\ \hline (\Delta_{Y,W}^{(T)} \otimes \text{id})\chi_{X,Y \otimes W} = (\text{id} \otimes \mu_X^{(Z_T)})(\text{id} \otimes \chi_{Z_T(X),W})(\chi_{X,Y} \otimes \text{id}). \end{array}$$

Lemma 6.3. *The centraliser (Z_T, χ) of an oplax monoidal endofunctor $T: \mathcal{C} \rightarrow \mathcal{C}$ is a monad with multiplication and unit as given in Equations (6.6) and (6.5).*

The above lemma is proven as the first part of [BV12, Theorem 5.6]. In it, the authors further consider $T: \mathcal{C} \rightarrow \mathcal{C}$ to be equipped with a Hopf monad structure and show that in this case Z_T is a Hopf monad as well. The extended factorisation property given in Lemma 6.2 allows us to reconstruct a comultiplication on Z_T from a twofold application of the universal coaction and the multiplication of T :

$$(6.7) \quad \begin{array}{c} \begin{array}{ccc} X & & Y & & W \\ & \searrow & \nearrow & & \\ & \bullet & & \bullet & \\ & \nearrow & & \nearrow & \searrow \\ T^2(W) & & T(W) & & Z_T(X) \\ \mu_W^{(T)} \end{array} & = & \begin{array}{ccc} X \otimes Y & & W \\ & \searrow & \nearrow \\ & \bullet & \\ & \nearrow & \searrow \\ T(W) & & Z_T(X) & & Z_T(Y) \\ \Delta_{X,Y}^{(Z_T)} \end{array} \\ \hline (\mu_W^{(T)} \otimes \text{id})(\chi_{X,W} \otimes \text{id})(\text{id} \otimes \chi_{Y,W}) = (\text{id} \otimes \Delta_{X,Y}^{(Z_T)})(\chi_{X \otimes Y,W}). \end{array}$$

Likewise, the unit of T induces a counit on Z_T via

$$(6.8) \quad \begin{array}{c} \begin{array}{c} X = 1 \otimes X \\ \eta_X^{(T)} \\ T(X) = T(X) \otimes 1 \end{array} & = & \begin{array}{c} \cdot 1 \\ \nearrow \\ \bullet \\ \searrow \\ T(X) \cdot 1 \\ \varepsilon^{(Z_T)} \\ Z_T(1) \end{array} \\ \hline \eta_X^{(T)} = (\text{id}_{T(X)} \otimes \varepsilon^{(Z_T)})\chi_{1,X}. \end{array}$$

A direct computation shows that the centraliser Z_T of T is a bimonad as well. For the construction of left and right antipodes we refer the reader to [BV12, Theorem 5.6].

Remark 6.4. Given an oplax monoidal functor $T: \mathcal{C} \rightarrow \mathcal{C}$, we think of $Z(T\mathcal{C})$ as the centre of an oplax bimodule category as stated in Remark 4.1, see also [BV07, Section 5.5]. Objects in $Z(T\mathcal{C})$ are pairs $(X, \sigma_{X,-})$, where $X \in \mathcal{C}$ and

$$\sigma_{X,Y}: X \otimes Y \rightarrow T(Y) \otimes X, \quad \text{for all } Y \in \mathcal{C}$$

is a natural transformation satisfying for all $X, Y, W \in \mathcal{C}$

$$(6.9) \quad (\Delta_{Y,W}^{(T)} \otimes \text{id}_X)\sigma_{X,Y \otimes W} = (\text{id}_{T(Y)} \otimes \sigma_{X,W})(\sigma_{X,Y} \otimes \text{id}_W)$$

$$(6.10) \quad (\varepsilon^{(T)} \otimes \text{id}_X)\sigma_{X,1} = \text{id}_X.$$

Analogous to the centres studied before, the morphisms in $Z(T\mathcal{C})$ are those morphisms of \mathcal{C} which commute with the respective half-braidings. If $T: \mathcal{C} \rightarrow \mathcal{C}$ is moreover a Hopf monad, Proposition 5.9 of [BV12] shows that the $Z(T\mathcal{C})$ is rigid monoidal. For example, the tensor product of two objects $(X, \sigma_{X,-}), (Y, \sigma_{Y,-}) \in Z(T\mathcal{C})$ is by $X \otimes Y \in \mathcal{C}$ together with the half-braiding

(6.11)

$$\sigma_{X \otimes Y, W} = (\mu_W^{(T)} \otimes \text{id}_{X \otimes Y})(\sigma_{X, T(W)} \otimes \text{id}_Y)(\text{id}_X \otimes \sigma_{Y, W}).$$

Since centralisers of Hopf monads are Hopf monads themselves, it stands to reason that their modules implement the twisted centres discussed in the previous remark as a rigid category. This is proven in [BV12, Theorem 5.12 and Corollary 5.14].

Theorem 6.5. *Suppose $T: \mathcal{C} \rightarrow \mathcal{C}$ to be a centralisable Hopf monad. The modules \mathcal{C}^{Z_T} of its centraliser (Z_T, χ) are isomorphic as a rigid category to $Z(T\mathcal{C})$.*

Applying the above theorem to the identity functor $\text{Id}: \mathcal{C} \rightarrow \mathcal{C}$, we obtain a Hopf monadic description of the Drinfeld centre $Z(\mathcal{C})$ of a rigid category \mathcal{C} . The terminology of our next definition is due to Shimizu, see [Shi17].

Definition 6.6. Let $\text{Id}: \mathcal{C} \rightarrow \mathcal{C}$ be centralisable with centraliser (Z, χ) . We call $\mathfrak{D}(\mathcal{C}) := (Z, \mu^{(Z)}, \eta^{(Z)}, \Delta^{(Z)}, \varepsilon^{(Z)}): \mathcal{C} \rightarrow \mathcal{C}$ the *central Hopf monad* of \mathcal{C} and denote the category of its modules by $\mathcal{C}^{\mathfrak{D}}$.

An important step in proving Theorem 6.5 is determining the comparison functor $\Sigma^{(Z_T)}: Z(T\mathcal{C}) \rightarrow \mathcal{C}^{Z_T}$ and its inverse. This construction will also play a substantial role in our monadic description of the anti-Drinfeld centre, hence why we recall it in its full generality. Let $T: \mathcal{C} \rightarrow \mathcal{C}$ be a centralisable oplax monoidal endofunctor with (Z_T, χ) as its centraliser. To every object $(M, \sigma_{M,-}) \in Z(T\mathcal{C})$ we assign a module over Z_T whose action $\vartheta_M^{(\sigma_M)}$ is uniquely defined by

(6.12)

$$\sigma_{M, X} = (\text{id}_X \otimes \vartheta_M^{(\sigma_M)})(\chi_{M, X}).$$

This leads to an explicit description of the comparison functor $\Sigma^{(Z_T)}: Z(T\mathcal{C}) \rightarrow \mathcal{C}^{Z_T}$. It is the identity on morphisms and on objects given by

(6.13) $\Sigma^{(Z_T)}(M, \sigma_{M,-}) = (M, \vartheta_M^{(\sigma_M)}), \quad \text{for all } (M, \sigma_{M,-}) \in Z(T\mathcal{C}).$

Conversely, to every module (M, ϑ_M) over Z_T we can associate a half-braiding $\sigma_{M,-}^{(\vartheta_M)}: M \otimes - \rightarrow T(-) \otimes M$. For any $X \in \mathcal{C}$ it is obtained by the composition

$$(6.14) \quad \begin{array}{c} \boxed{\begin{array}{c} \begin{array}{c} M \quad X \\ \diagdown \quad \diagup \\ \bullet \\ \diagup \quad \diagdown \\ T(X) \quad M \\ \boxed{\vartheta_M} \end{array} \end{array}} \\ \sigma_{M,X}^{(\vartheta_M)} = (\text{id}_{T(X)} \otimes \vartheta_M)_{\chi_{M,X}}: M \otimes X \rightarrow T(X) \otimes M. \end{array}$$

This yields another functor $E^{(Z_T)}: \mathcal{C}^{Z_T} \rightarrow Z(T\mathcal{C})$ that again is the identity on morphisms and whose value on objects is

$$(6.15) \quad E^{(Z_T)}(M, \vartheta_M) = (M, \sigma_{M,-}^{(\vartheta_M)}), \quad \text{for all } (M, \vartheta_M) \in \mathcal{C}^{Z_T}.$$

Remark 6.7. Suppose $T: \mathcal{C} \rightarrow \mathcal{C}$ to be a centralisable oplax monoidal endofunctor with (Z_T, χ) as its centraliser. Denote the free functor of the Eilenberg–Moore adjunction of Z_T by $F_{Z_T}: \mathcal{C} \rightarrow \mathcal{C}^{Z_T}$. The composition

$$(6.16) \quad \mathcal{C} \xrightarrow{F_{Z_T}} \mathcal{C}^{Z_T} \xrightarrow{E^{(Z_T)}} Z(T\mathcal{C})$$

defines a left adjoint of the canonical forgetful functor $U^{(T)}: Z(T\mathcal{C}) \rightarrow \mathcal{C}$.

We recall [BV12, Theorem 5.12], which proves the adjunction of the previous remark to be monadic.

Theorem 6.8. *Assume (Z_T, χ) to be a centraliser of the oplax monoidal endofunctor $T: \mathcal{C} \rightarrow \mathcal{C}$. The comparison functor $\Sigma^{(Z_T)}: Z(T\mathcal{C}) \rightarrow \mathcal{C}^{Z_T}$ is an isomorphism of categories whose inverse is the canonical functor $E^{(Z_T)}: \mathcal{C}^{Z_T} \rightarrow Z(T\mathcal{C})$.*

6.2. Centralisers and comodule monads. We will now apply the methods of Bruguières and Virelizier to twisted centres for the purpose of obtaining a comodule monad that implements the anti-Drinfeld centre. Hereto, we need a generalised version of the concept of modules over a monad. Our approach is based on [MW11].

Definition 6.9. Suppose $B: \mathcal{C} \rightarrow \mathcal{C}$ to be a bimonad and $L: \mathcal{C} \rightarrow \mathcal{D}$ an oplax monoidal functor. An *oplax monoidal right action* of B on L is an oplax natural transformation $\alpha: LB \rightarrow L$, such that for all $X \in \mathcal{D}$

$$(6.17) \quad \alpha_X \alpha_{B(X)} = \alpha_X L(\mu_X^{(B)}) \quad \text{and} \quad \alpha_X L(\eta_X^{(B)}) = \text{id}_{L(X)}.$$

Similarly, we could define oplax monoidal left actions. A prime example of the latter is given by the forgetful functor $U_B: \mathcal{C}^B \rightarrow \mathcal{C}$ of a bimonad $B: \mathcal{C} \rightarrow \mathcal{C}$ together with the action displayed in Diagram (5.11).

To keep our notation concise, in the following we fix an oplax monoidal functor $L: \mathcal{C} \rightarrow \mathcal{C}$ with an oplax right action $\alpha: LB \rightarrow L$ by a bimonad $B: \mathcal{C} \rightarrow \mathcal{C}$ and assume that L and B are centralisable. Their centralisers will be denoted by (Q, ξ) and (Z, χ) , respectively.

We think of $Z(B\mathcal{C})$ as a more general version of the Drinfeld centre which is supposed to act on $Z(L\mathcal{C})$ from the right. To emphasise this, and in line with the colouring scheme of Section 4, we use black for objects in \mathcal{C} or its generalised Drinfeld centre $Z(B\mathcal{C})$ and blue for objects in $Z(L\mathcal{C})$.

Consider two objects $(M, \sigma_M, -) \in \mathcal{Z}(\mathcal{L}\mathcal{C})$ and $(X, \sigma_X, -) \in \mathcal{Z}(\mathcal{B}\mathcal{C})$. The action of B on L , combined with the half-braidings of M and X , yields a natural transformation

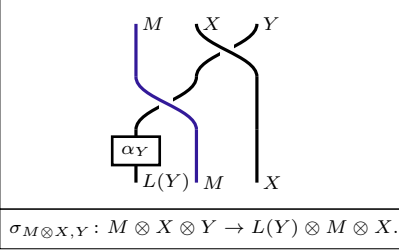
(6.18) 

Lemma 6.10. *The centre $\mathcal{Z}(\mathcal{B}\mathcal{C})$ acts on $\mathcal{Z}(\mathcal{L}\mathcal{C})$ from the right by tensoring the underlying objects and gluing together the half-braidings as in Equation (6.18). With respect to this action, the forgetful functor $U^{(L)} : \mathcal{Z}(\mathcal{L}\mathcal{C}) \rightarrow \mathcal{C}$ is a strict comodule functor over $U^{(B)} : \mathcal{Z}(\mathcal{B}\mathcal{C}) \rightarrow \mathcal{C}$.*

Proof. We proceed as in [BV12, Proposition 5.9] and fix objects $(M, \sigma_M, -) \in \mathcal{Z}(\mathcal{L}\mathcal{C})$ and $(X, \sigma_X, -) \in \mathcal{Z}(\mathcal{B}\mathcal{C})$. The compatibility of the half-braiding of $M \otimes X$ with the unit of \mathcal{C} is a short computation:

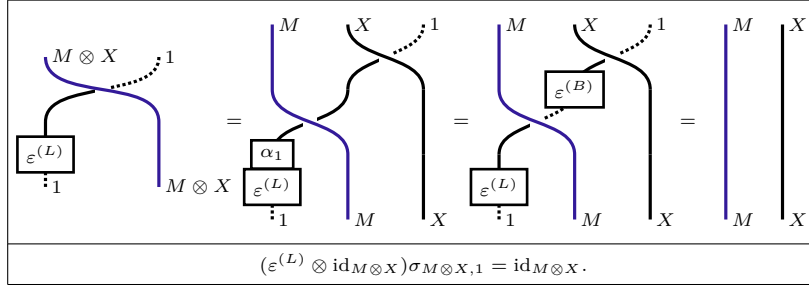

$(\varepsilon^{(L)} \otimes \text{id}_{M \otimes X}) \sigma_{M \otimes X, 1} = \text{id}_{M \otimes X}$.

Similarly, we verify the hexagon axiom:

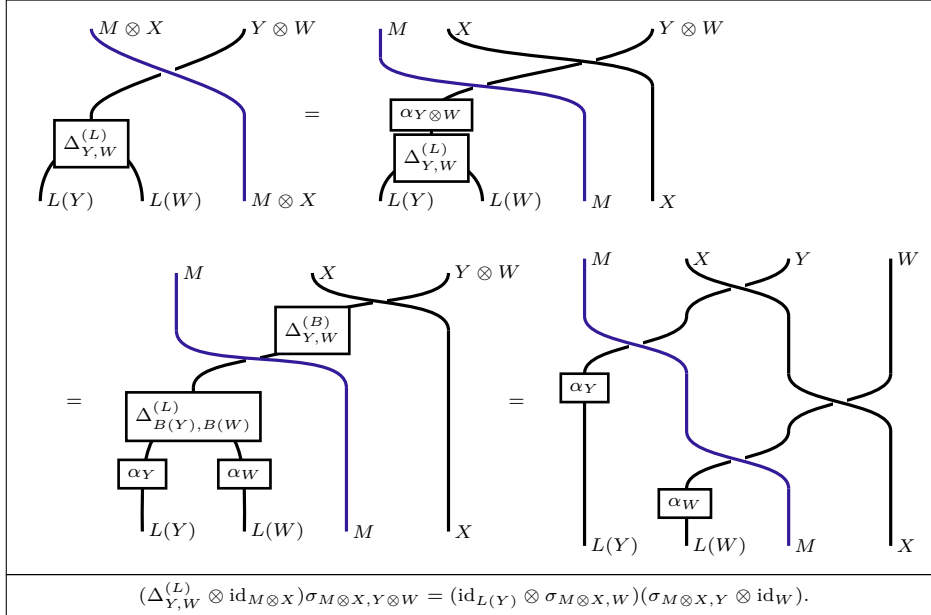

$(\Delta_{Y,W}^{(L)} \otimes \text{id}_{M \otimes X}) \sigma_{M \otimes X, Y \otimes W} = (\text{id}_{L(Y)} \otimes \sigma_{M \otimes X, W}) (\sigma_{M \otimes X, Y} \otimes \text{id}_W)$.

The compatibility of the action $\alpha: LB \rightarrow L$ with the multiplication and unit of B asserts that $Z(L\mathcal{C})$ is a right module of the generalised Drinfeld centre $Z(B\mathcal{C})$.

By construction, we have for all $(M, \sigma_{M,-}) \in Z(L\mathcal{C})$ and $(X, \sigma_{X,-}) \in Z(B\mathcal{C})$

$$U^{(L)}((M, \sigma_{M,-}) \triangleleft (X, \sigma_{X,-})) = M \otimes X = U^{(L)}(M, \sigma_{M,-}) \otimes U^{(B)}(X, \sigma_{X,-}).$$

Thus, $U^{(L)}$ is a strict comodule functor over $U^{(B)}$. \square

We extend our colouring scheme to universal coactions and write

$\xi_{X,Y}: X \otimes Y \rightarrow L(Y) \otimes Q(X),$	$\chi_{X,Y}: X \otimes Y \rightarrow B(Y) \otimes Z(X).$

The identification of \mathcal{C}^Z and \mathcal{C}^Q with the generalised Drinfeld centre and its twisted cousin suggest that Q is a comodule monad over Z . In analogy with Equation (6.7), we define a candidate for the coaction of Q by

$(\alpha_W \otimes \text{id})(\xi_{X,B(W)} \otimes \text{id})(\text{id} \otimes \chi_{Y,W}) = (\text{id} \otimes \delta_{X,Y}^{(Q)})(\xi_{X \otimes Y,W}).$	

Theorem 6.11. *Let $\alpha: LB \rightarrow L$ be an oplax monoidal right action of a bimonad $B: \mathcal{C} \rightarrow \mathcal{C}$ on an oplax monoidal functor $L: \mathcal{C} \rightarrow \mathcal{C}$. Suppose furthermore that the centralisers (Q, ξ) of L and (Z, χ) of B exist. The coaction of Equation (6.20) turns Q into a comodule monad over Z such that \mathcal{C}^Q is isomorphic as a right module category over \mathcal{C}^Z to $Z(L\mathcal{C})$.*

Proof. By Remark 6.7 and Theorem 6.8 we have monadic adjunctions

$$F^{(B)}: \mathcal{C} \rightleftarrows Z(B\mathcal{C}) : U^{(B)} \quad \text{and} \quad F^{(L)}: \mathcal{C} \rightleftarrows Z(L\mathcal{C}) : U^{(L)}$$

which, due to [BV12, Remark 5.13], give rise to the bimonad Z and monad Q , respectively. Lemma 6.10 shows that $U^{(L)}$ is a strict comodule functor over $U^{(B)}$ and therefore, by Theorem 5.21, we obtain that Q is a comodule monad over B . Following Corollary 5.22, the coaction $\lambda: Q(- \otimes -) \rightarrow Q(-) \otimes Z(-)$ implementing the action of \mathcal{C}^Z on \mathcal{C}^Q is for all $X, Y \in \mathcal{C}$ given by

$$(6.21) \quad \lambda_{X,Y} = \vartheta_{Q(X) \otimes Z(Y)} Q(\eta_X^{(Q)} \otimes \eta_Y^{(Z)}).$$

By using the relation between universal coactions and half-braidings, explained in Equation (6.14), and applying the hexagon identity we compute:

(6.22)

The uniqueness property of universal coactions implies $\lambda = \delta^{(Q)}$.

It remains to show that \mathcal{C}^Q and $Z(L\mathcal{C})$ are isomorphic as modules over \mathcal{C}^Z . Note that by Lemmas 5.12 and 5.13 as well as Theorem 5.21 and Lemma 5.23, the comparison functor $\Sigma^{(Z)}: Z(B\mathcal{C}) \rightarrow \mathcal{C}^Z$ is strong monoidal and $\Sigma^{(Q)}: Z(L\mathcal{C}) \rightarrow \mathcal{C}^Q$ is a strong comodule functor over it. Furthermore, due to Theorem 6.8, both $\Sigma^{(Z)}$ and $\Sigma^{(Q)}$ admit inverses

$$E^{(Z)}: \mathcal{C}^Z \rightarrow Z(B\mathcal{C}) \quad \text{and} \quad E^{(Q)}: \mathcal{C}^Q \rightarrow Z(L\mathcal{C}).$$

Using that $E^{(Z)}$ is monoidal as well, we identify the right action of $Z(B\mathcal{C})$ on $Z(L\mathcal{C})$ with a right action $\blacktriangleleft: Z(L\mathcal{C}) \times \mathcal{C}^Z \rightarrow Z(L\mathcal{C})$ of \mathcal{C}^Z by setting

$$Z(L\mathcal{C}) \times \mathcal{C}^Z \xrightarrow{\text{Id} \times E^{(Z)}} Z(L\mathcal{C}) \times Z(B\mathcal{C}) \xrightarrow{(-) \blacktriangleleft (-)} Z(L\mathcal{C}).$$

For any $M \in Z(L\mathcal{C})$ and $X \in Z(L\mathcal{C})$ we have

$$\Sigma^{(Q)}(M \blacktriangleleft X) = \Sigma^{(Q)}(M \blacktriangleleft E^{(Z)}(X)) \xrightarrow{\delta^{\Sigma^{(Q)}}} \Sigma^{(Q)}(M) \blacktriangleleft \Sigma^{(Z)} E^{(Z)}(X) = \Sigma^{(Q)}(M) \blacktriangleleft X$$

The second and third part of the above mentioned theorem state that Q is a lift of the monad Q_H and Z is a lift of the bimonad Z_H . It remains for us to show that the coactions of Q and Q_H are compatible with the forgetful functor $U_H: \mathcal{V}^H \rightarrow \mathcal{V}$. We fix objects $(X, \vartheta_X), (Y, \vartheta_Y) \in \mathcal{V}^H$ and $W \in \mathcal{V}$ and compute:

$$\begin{aligned}
& \begin{array}{c} U_H(X \otimes Y) \\ \tau \\ \downarrow \\ L \times H(W) \end{array} \begin{array}{c} W \\ \downarrow \\ Q_H(X) \end{array} \begin{array}{c} U_H(\delta_{X,Y}^{(Q)}) \\ \downarrow \\ Z_H(Y) \end{array} = \begin{array}{c} U_H(X \otimes Y) \\ \tau \\ \downarrow \\ L \times H(W) \end{array} \begin{array}{c} U_H L(F_H(\eta_W^{(H)})) \\ \downarrow \\ Q_H(X) \end{array} \begin{array}{c} U_H(\delta_{X,Y}^{(Q)}) \\ \downarrow \\ Z_H(Y) \end{array} \\
& \begin{array}{c} U_H(X \otimes Y) \\ \tau \\ \downarrow \\ L \times H(W) \end{array} \begin{array}{c} U_H L(\epsilon_{F_H(W)}) \\ \downarrow \\ Q_H(X) \end{array} \begin{array}{c} U_H(\delta_{X,Y}^{(Q)}) \\ \downarrow \\ Z_H(Y) \end{array} = \begin{array}{c} U_H(X \otimes Y) \\ \tau \\ \downarrow \\ L \times H(W) \end{array} \begin{array}{c} U_H(\epsilon) \\ \downarrow \\ Q_H(X) \end{array} \begin{array}{c} U_H(\delta_{X,Y}^{(Q)}) \\ \downarrow \\ Z_H(Y) \end{array} \\
& \begin{array}{c} U_H(X \otimes Y) \\ \tau \\ \downarrow \\ L \times H(W) \end{array} \begin{array}{c} U_H(\epsilon) \\ \downarrow \\ Q_H(X) \end{array} \begin{array}{c} U_H(\delta_{X,Y}^{(Q)}) \\ \downarrow \\ Z_H(Y) \end{array} = \begin{array}{c} U_H(X) \\ U_H(\epsilon) \\ \downarrow \\ L \times H(W) \end{array} \begin{array}{c} U_H(Y) \\ U_H(x) \\ \downarrow \\ Q_H(X) \end{array} \begin{array}{c} W \\ \eta_W^{(H)} \\ \downarrow \\ Z_H(Y) \end{array} \\
& \begin{array}{c} U_H(X) \\ U_H(\epsilon) \\ \downarrow \\ L \times H(W) \end{array} \begin{array}{c} U_H(Y) \\ U_H(x) \\ \downarrow \\ Q_H(X) \end{array} \begin{array}{c} W \\ \eta_W^{(H)} \\ \downarrow \\ Z_H(Y) \end{array} = \begin{array}{c} U_H(X) \\ \tau \\ \downarrow \\ L \times H(W) \end{array} \begin{array}{c} U_H(Y) \\ \zeta \\ \downarrow \\ Q_H(X) \end{array} \begin{array}{c} W \\ \alpha_{HW} \\ \downarrow \\ Z_H(Y) \end{array} \\
& \begin{array}{c} U_H(X \otimes Y) \\ \tau \\ \downarrow \\ L \times H(W) \end{array} \begin{array}{c} U_H(\delta_{X,Y}^{(Q_H)}) \\ \downarrow \\ Q_H(X) \end{array} \begin{array}{c} W \\ \downarrow \\ Z_H(Y) \end{array} \\
& (\text{id}_{L \times H(W)} \otimes U_H(\delta_{(X, \vartheta_X), (Y, \vartheta_Y)}^{(Q)})) \tau_{U_H(X \otimes Y), W} = (\text{id}_{L \times H(X)} \otimes \delta_{X, Y}^{(Q_H)}) \tau_{U_H(X \otimes Y), W}.
\end{aligned}$$

The uniqueness property of universal coactions as given in Lemma 6.2 then implies that $U_H(\delta_{(X, \vartheta_X), (Y, \vartheta_Y)}^{(Q)}) = \delta_{X, Y}^{(Q_H)}$. Since $U_H: \mathcal{V}^H \rightarrow \mathcal{V}$ is a strict comodule functor, the claim follows. \square

The previous theorem together with Lemma 5.25 imply that we obtain a comodule monad $D(L, H) := Q \times H$ over $D(B, H) := Z \times H$. The correspondence between lifts and monads given in Theorem 5.29 yields a unique comodule distributive law $(HQ_H \xrightarrow{\Omega} Q_H H, HZ_H \xrightarrow{\Lambda} Z_H H)$ such that

$$(6.24) \quad D(L, H) = Q_H \circ_{\Omega} H \quad \text{and} \quad D(B, H) = Z_H \circ_{\Lambda} H.$$

Definition 6.15. We call $D(B, H)$ and $D(L, H)$ the *double* and *twisted double* of the pairs (B, H) and (L, H) .

The relationship between doubles and generalised Drinfeld centres is explained in [BV12, Proposition 7.5 and Theorem 7.6]. Our next result uses the same techniques to prove how twisted doubles parametrise twisted centres.

Theorem 6.16. *The twisted double $D(L, H)$ is a comodule monad over $D(B, H)$ and $\mathcal{V}^{D(L, H)}$ is isomorphic as a module category over $\mathcal{V}^{D(B, H)}$ to $Z(L)\mathcal{V}^H$.*

Proof. Since Q is a lift of Q_H as a comodule monad, the twisted double $D(L, H)$ is a comodule monad over $D(B, H)$. By Lemma 5.30, this implies the existence of an isomorphism of $\mathcal{V}^{D(B, H)}$ -module categories $K^{(\Omega)}: \mathcal{V}^{D(L, H)} \rightarrow (\mathcal{V}^H)^Q$. Due to the proof of Theorem 6.11 the comparison functor $\Sigma^{(Q)}: Z(L)\mathcal{V}^H \rightarrow (\mathcal{V}^H)^Q$ implements an isomorphism of module categories and the statement follows by considering

$$(6.25) \quad \mathcal{V}^{D(L, H)} \xrightarrow{K^{(\Omega)}} (\mathcal{V}^H)^Q \xrightarrow{E^{(Q)}} Z(L)\mathcal{V}^H.$$

□

Definition 6.17. Suppose $B = \text{Id}_{\mathcal{V}^H}: \mathcal{V}^H \rightarrow \mathcal{V}^H$ and $L = (-)^{\vee\vee}: \mathcal{V}^H \rightarrow \mathcal{V}^H$. We refer to $D(H) := D(B, H)$ and $Q(H) := D(L, H)$ as the *Drinfeld* and *anti-Drinfeld double* of H .

Our previous definition can be understood as an extension of the notion of the anti-Drinfeld double given by [HKRS04a] to the monadic framework.

6.4. Pairs in involution for Hopf monads. For the final step in our investigation, let us consider a Hopf monad $H: \mathcal{V} \rightarrow \mathcal{V}$ which admits a double and anti-double. Tracing the various identifications of the centre and anti-centre of a monoidal category given in Figure 2, we observe that module functors from $Z(\mathcal{V}^H)$ to $Q(\mathcal{V}^H)$ equate bidirectionally to module functors between $\mathcal{V}^{D(H)}$ and $\mathcal{V}^{Q(H)}$. In the spirit of viewing $D(H)$ and $Q(H)$ as ‘coordinate systems’ of their respective modules, we want to translate such functors into comodule monad morphisms. Our main focus here is on pivotal structures of $\mathcal{V}^{D(H)}$.

We begin by developing the notion of pairs in involution for a Hopf monad. Classically, pairs in involution consist of a group-like and character of a Hopf algebra, which implement the square of its antipode by their adjoint actions.

Definition 6.18. Let $H: \mathcal{V} \rightarrow \mathcal{V}$ be a Hopf monad. A *character* of H is a module $\beta := (1, \vartheta_\beta) \in \mathcal{V}^H$, whose underlying object is the monoidal unit of \mathcal{V} .

A *group-like* element of H is a natural transformation $g: \text{Id}_{\mathcal{V}} \rightarrow H$ satisfying for all $X, Y \in \mathcal{V}$

$$(6.26) \quad \Delta_{X, Y}^{(H)} g_{X \otimes Y} = g_X \otimes g_Y \quad \text{and} \quad \varepsilon^{(H)} g_1 = \text{id}_1.$$

We write $\text{Char}(H)$ for the characters of H and $\text{Gr}(H)$ for its group-likes.

Note that the characters $\text{Char}(H)$ of a Hopf-monad $H: \mathcal{V} \rightarrow \mathcal{V}$ form a monoid and, by Lemma [BV07, Lemma 3.21], the set $\text{Gr}(H)$ of group-like elements bears a group structure.

Furthermore, the group-likes of a Hopf monad H act on it by conjugation. We recall this construction based on [BV07, Section 1.4]. Given a natural transformation $g: \text{Id}_{\mathcal{C}} \rightarrow H$, we define the *left* and *right regular action* of g on H to be the natural transformations defined for every $X \in \mathcal{V}$ by

$$(6.27) \quad L_{g, X} := H(X) \xrightarrow{g_{H(X)}} H^2(X) \xrightarrow{\mu_X^{(H)}} H(X),$$

$$(6.28) \quad R_{g, X} := H(X) \xrightarrow{H(g_X)} H^2(X) \xrightarrow{\mu_X^{(H)}} H(X).$$

Before we state our next definition, we set for all $X, Y, W \in \mathcal{V}$

$$(6.29) \quad \Delta_{X,Y,W}^{(H)} := (\Delta_{X,Y}^{(H)} \otimes \text{id}_{H(W)})\Delta_{X \otimes Y, W}^{(H)} = (\text{id}_{H(X)} \otimes \Delta_{Y,W}^{(H)})\Delta_{X, Y \otimes W}^{(H)}.$$

Definition 6.19. Every group-like $g \in \text{Gr}(H)$ and character $\beta \in \text{Char}(H)$ of a Hopf monad $H: \mathcal{V} \rightarrow \mathcal{V}$ give rise to natural transformations

$$(6.30) \quad \text{Ad}_{g,X} := R_{g^{-1},X} L_{g,X}: H(X) \rightarrow H(X), \quad \text{for all } X \in \mathcal{V},$$

$$(6.31) \quad \text{Ad}_{\beta,X} := (\vartheta_\beta \otimes \text{id}_{H(X)} \otimes \vartheta_{\beta^\vee})\Delta_{1,X,1}^{(H)}: H(X) \rightarrow H(X), \quad \text{for all } X \in \mathcal{V}.$$

called the *adjoint actions* of g and β on H , respectively.

To define pairs in involution, we need the ‘square of the antipode’. This notion was developed in [BV07, Section 7.3].

Definition 6.20. Suppose $\phi: \text{Id}_{\mathcal{V}} \rightarrow (-)^{\vee\vee}$ to be a pivotal structure on \mathcal{V} and let $H: \mathcal{V} \rightarrow \mathcal{V}$ be a Hopf monad. The *square of the antipode* of H is a natural transformation $S^2: H \rightarrow H$, which is defined for every $X \in \mathcal{V}$ by

$$(6.32) \quad S_X^2 := \phi_{H(X)}^{-1} s_{H(X)^\vee}^l H(s_X^l) H(\phi_X).$$

Analogous to the Hopf algebraic case, we state the following:

Definition 6.21. A *pair in involution* for a Hopf monad $H: \mathcal{V} \rightarrow \mathcal{V}$ consists of a group-like $g \in \text{Gr}(H)$ and character $\beta \in \text{Char}(H)$ such that for all $X \in \mathcal{V}$

$$(6.33) \quad \text{Ad}_{g,X} = \text{Ad}_{\beta,X} S_X^2.$$

To prove that pairs in involution correspond to certain pivotal structures on the Drinfeld centre of \mathcal{V}^H , we need two technical results. The first is a special case of [BV07, Lemma 1.3].

Lemma 6.22. *Let $H: \mathcal{V} \rightarrow \mathcal{V}$ be a monad with associated forgetful functor $U_H: \mathcal{V}^H \rightarrow \mathcal{V}$. Then there exists a canonical bijection*

$$(6.34) \quad (-)^\sharp: \text{Nat}(\text{Id}_{\mathcal{V}}, H) \rightarrow \text{Nat}(HU_H, U_H), \quad f \mapsto f^\sharp,$$

where $f_{(M, \vartheta_M)}^\sharp = \vartheta_M f_M$.

The next lemma is a variant of [BV07, Lemma 7.5].

Lemma 6.23. *Let $\phi: \text{Id}_{\mathcal{V}} \rightarrow (-)^{\vee\vee}$ be a pivotal structure on \mathcal{V} and $H: \mathcal{V} \rightarrow \mathcal{V}$ a Hopf monad. For any group-like $g \in \text{Gr}(H)$ and character $\beta \in \text{Char}(H)$ the following are equivalent:*

- (i) *The arrows g and β form a pair in involution.*
- (ii) *The natural arrow $\phi g^\sharp \in \text{Nat}(U_H, U_H)$ lifts to $\text{Nat}(\text{Id}_{\mathcal{V}^H}, \beta \otimes (-)^{\vee\vee} \otimes \beta^\vee)$.*

Proof. Consider a module $(M, \vartheta_M) \in \mathcal{V}^H$. By [BV07, Theorem 3.8(a)] and the definition of S^2 , the action on $M^{\vee\vee}$ is given by

$$\vartheta_{M^{\vee\vee}} = \vartheta_M^{\vee\vee} s_{H(M)^{\vee\vee}}^l H(s_M^l) = \phi_M \vartheta_M S_M^2 H(\phi_M^{-1})$$

and therefore we have

$$\vartheta_{\beta \otimes M^{\vee\vee} \otimes \beta^\vee} = (\vartheta_\beta \otimes \vartheta_{M^{\vee\vee}} \otimes \vartheta_{\beta^\vee})\Delta_{1,M,1}^{(H)} = (\vartheta_\beta \otimes \phi_M \vartheta_M S_M^2 H(\phi_M^{-1}) \otimes \vartheta_{\beta^\vee})\Delta_{1,M,1}^{(H)}.$$

By definition ϕg^\sharp lifts to a natural transformation from $\text{Id}_{\mathcal{V}^H}$ to $\beta \otimes (-)^{\vee\vee} \otimes \beta^\vee$, if and only if for any H -module (M, ϑ_M) , we have

$$(6.35) \quad (\phi g^\sharp)_M \vartheta_M = \vartheta_{\beta \otimes M^{\vee\vee} \otimes \beta^\vee} H((\phi g^\sharp)_M).$$

Let us now successively simplify both sides of the equation. Using the naturality of $g: \text{Id}_{\mathcal{V}} \rightarrow H$, the fact that ϑ_M is an action and the definition of g^\sharp as given in Lemma 6.22, we can rewrite the left hand side of the equation as

$$\begin{aligned} (\phi g^\sharp)_M \vartheta_M &= \phi_M \vartheta_M g_M \vartheta_M = \phi_M \vartheta_M H(\vartheta_M) g_{H(M)} \\ &= \phi_M \vartheta_M \mu_M^{(H)} g_{H(M)}. \end{aligned}$$

Similarly, we simplify the right-hand side to

$$\begin{aligned} \vartheta_{\beta \otimes M^{\vee\vee} \otimes \beta^\vee} H((\phi g^\sharp)_M) &= (\vartheta_\beta \otimes \phi_M \vartheta_M S_M^2 H(\phi_M^{-1}) \otimes \vartheta_{\beta^\vee}) \Delta_{1,M,1}^{(H)} H((\phi g^\sharp)_M) \\ &= (\vartheta_\beta \otimes \phi_M \vartheta_M S_M^2 H(\phi_M^{-1}) H((\phi g^\sharp)_M) \otimes \vartheta_{\beta^\vee}) \Delta_{1,M,1}^{(H)} \\ &= (\vartheta_\beta \otimes \phi_M \vartheta_M S_M^2 H(\vartheta_M g_M) \otimes \vartheta_{\beta^\vee}) \Delta_{1,M,1}^{(H)} \\ &= (\vartheta_\beta \otimes \phi_M \vartheta_M H(\vartheta_M g_M) S_M^2 \otimes \vartheta_{\beta^\vee}) \Delta_{1,M,1}^{(H)} \\ &= \phi_M \vartheta_M H(\vartheta_M g_M) (\vartheta_\beta \otimes \text{id}_{H(M)} \otimes \vartheta_{\beta^\vee}) \Delta_{1,M,1}^{(H)} S_M^2 \\ &= \phi_M \vartheta_M \mu_M^{(H)} H(g_M) \text{Ad}_{\beta,M} S_M^2. \end{aligned}$$

Using the fact that ϕ is an isomorphism, Equation (6.35) can thus be restated as

$$\begin{aligned} \vartheta_M \mu_M^{(H)} g_{H(M)} &= \vartheta_M \mu_M^{(H)} H(g_M) \text{Ad}_{\beta,M} S_M^2 \\ \iff \vartheta_M L_{g,M} &= \vartheta_M R_{g,M} \text{Ad}_{\beta,M} S_M^2 \end{aligned}$$

Since $(-)^\sharp$ is a bijection by Lemma 6.22, the above equation is equivalent to $L_{g,M} = R_{g,M} \text{Ad}_{\beta,M} S_M^2$. We conclude the proof by multiplying both sides with $R_{g^{-1},M}$. \square

The previous lemma leads to an identification of pairs in involution of H with certain quasi-pivotal structures on \mathcal{V}^H .

Theorem 6.24. *Suppose $H: \mathcal{V} \rightarrow \mathcal{V}$ to be a Hopf monad on a pivotal category \mathcal{V} . Then H admits a pair in involution if and only if there exists a quasi-pivotal structure on \mathcal{V}^H that is given for any $X \in \mathcal{V}^H$ and $\beta \in \text{Char}(H)$ by*

$$(6.36) \quad \rho_{\beta,X}: X \rightarrow \beta \otimes X^{\vee\vee} \otimes \beta^\vee.$$

Proof. We fix a pivotal structure $\phi: \text{Id}_{\mathcal{V}} \rightarrow (-)^{\vee\vee}$ on \mathcal{V} and proceed analogous to [BV07, Proposition 7.6]. Suppose $g \in \text{Gr}(H)$ and $\beta \in \text{Char}(H)$ to constitute a pair in involution for H . By the previous lemma, ϕg^\sharp lifts to a natural isomorphism

$$\rho_{\beta,X}: X \rightarrow \beta \otimes X^{\vee\vee} \otimes \beta^\vee, \quad \text{for all } X \in \mathcal{V}^H.$$

Since ϕ is monoidal by definition and g^\sharp is monoidal by virtue of g being a group-like, see for example [BV07, Lemma 3.20], we obtain a quasi-pivotal structure $\rho_\beta: \text{Id}_{\mathcal{V}^H} \rightarrow \beta \otimes (-)^{\vee\vee} \otimes \beta^\vee$.

On the other hand, consider a quasi-pivotal structure (β, ρ_β) , where $\beta \in \text{Char}(H)$ is a character. Since the forgetful functor U_H is strong monoidal and thus

$$U_H(\beta \otimes (-)^{\vee\vee} \otimes \beta^\vee) = U_H((-)^{\vee\vee}) = (U_H(-))^{\vee\vee},$$

there exists a monoidal natural transformation

$$\phi_{U_H(X)}^{-1} U_H(\rho_{\beta,X}): U_H(X) \rightarrow U_H(X), \quad \text{for all } X \in \mathcal{V}^H.$$

Again, we apply [BV07, Lemma 3.20] and obtain a unique group-like $g \in \text{Gr}(H)$ such that $g^\sharp = \phi_{U_H(X)}^{-1} U_H(\rho_{\beta, X})$. As $\phi g^\sharp = U_H(\rho_\beta)$ lifts to the quasi-pivotal structure (β, ρ_β) on \mathcal{V}^H , Lemma 6.23 implies that g and β form a pair in involution. \square

Let us now study a variant of [BV07, Lemma 2.9].

Theorem 6.25. *Assume $K, C: \mathcal{M} \rightarrow \mathcal{M}$ to be two comodule monads over a bimonad $B: \mathcal{C} \rightarrow \mathcal{C}$. There is a bijective correspondence between morphisms of comodule monads $f: K \rightarrow C$ and strict module functors $F: \mathcal{M}^C \rightarrow \mathcal{M}^K$ such that $U_K F = U_C$.*

Proof. As shown for example in [BV07, Lemma 1.7], we know that any functor $F: \mathcal{M}^C \rightarrow \mathcal{M}^K$ with $U_K F = U_C$ is ‘induced’ by a unique morphism of monads $f: K \rightarrow C$. That is, F is the identity on morphisms and on objects it is defined by

$$F(M, \vartheta_M) = (M, \vartheta_M f_M), \quad \text{for all } (M, \vartheta_M) \in \mathcal{M}^C.$$

It remains to show that f is a morphism of comodules if and only if F is a strict module functor in the sense of Definition 2.15. Let $(M, \vartheta_M) \in \mathcal{M}^C$ and $(X, \vartheta_X) \in \mathcal{C}^B$. We compute

$$\begin{aligned} F((M, \vartheta_M) \triangleleft (X, \vartheta_X)) &= (M \triangleleft X, (\vartheta_M \triangleleft \vartheta_X) \delta_{M, X}^{(C)} f_{M \triangleleft X}), \\ F(M, \vartheta_M) \triangleleft (X, \vartheta_X) &= (M \triangleleft X, (\vartheta_M \triangleleft \vartheta_X) (f_M \triangleleft \text{id}_{B(X)}) \delta_{M, X}^{(K)}). \end{aligned}$$

According to [BV07, Lemma 1.4], these modules coincide if and only if

$$\delta_{M, X}^{(C)} f_{M \triangleleft X} = (f_M \triangleleft \text{id}_{B(X)}) \delta_{M, X}^{(K)},$$

which is exactly the condition for f to be a comodule morphism. \square

The above result readily implies the desired monadic version of the Hajac–Sommerhäuser characterisation of pairs in involution as stated Theorem 1.1.

Theorem 6.26. *Let $H: \mathcal{V} \rightarrow \mathcal{V}$ be a Hopf monad that admits a double $D(H)$ and anti-double $Q(H)$. The following statements are equivalent:*

- (i) *The monoidal unit $1 \in \mathcal{V}$ lifts to a module over $Q(H)$.*
- (ii) *The Drinfeld double and anti-Drinfeld double of H are isomorphic as comodule monads.*
- (iii) *There is an isomorphism of monads $g: Q(H) \rightarrow D(H)$.*

Additionally, if \mathcal{V} is pivotal, one of the above statements holds if and only if H admits a pair in involution.

Proof. (i) \implies (ii): suppose $\omega \in \mathbf{Q}(\mathcal{V}^H)$ with $U_{Q(H)}(\omega) = 1$. As shown in Equation (4.6), it induces a functor of module categories

$$\omega \otimes -: \mathcal{V}^{D(H)} \rightarrow \mathcal{V}^{Q(H)}.$$

Since $U_{Q(H)}(\omega) = 1 \in \mathcal{V}$, we can apply Theorem 6.25 and obtain that $Q(H)$ and $D(H)$ are isomorphic as comodule monads.

It immediately follows that (ii) implies (iii); we proceed with (iii) \implies (i): consider an isomorphism of monads $f: Q(H) \rightarrow D(H)$. It gives rise to a functor $G: \mathcal{V}^{D(H)} \rightarrow \mathcal{V}^{Q(H)}$ that, on objects, is defined by

$$G(M, \vartheta_M) = (M, \vartheta_M f_M), \quad \text{for all } (M, \vartheta_M) \in \mathcal{C}^Z.$$

We compose G with the inverse of the comparison functor $E^{(Q(H))}: \mathcal{V}^{Q(H)} \rightarrow \mathbf{Q}(\mathcal{C})$, defined in Equation (6.15), and see that there exists an object

$$1^{(Q)} := E^{(Q(H))}G(1) \in \mathbf{Q}(\mathcal{C})$$

whose underlying object is the unit of \mathcal{V} .

Now let \mathcal{V} be pivotal. By Lemma 4.12, lifts of $1 \in \mathcal{V}$ to the dual of the anti-centre $\mathbf{Q}(\mathcal{V}^H)$ are in correspondence with quasi-pivotal structures (β, ρ_β) , where $\beta \in \text{Char}(H)$. By Theorem 6.24 such a quasi-pivotal structure exists if and only if H admits a pair in involution. \square

As a corollary, we can determine whether a category is pivotal in terms of monad isomorphisms between the central and anti-central monad

Corollary 6.27. *Assume \mathcal{C} to admit a central and anti-central monad. Then \mathcal{C} is pivotal if and only if $\mathfrak{D}(\mathcal{C})$ and $\mathfrak{Q}(\mathcal{C})$ are isomorphic as monads.*

Proof. We consider the identity $\text{Id}_{\mathcal{C}}: \mathcal{C} \rightarrow \mathcal{C}$ as a Hopf monad. Its Drinfeld and anti-Drinfeld double are $D(\text{Id}_{\mathcal{C}}) = \mathfrak{D}(\mathcal{C}) \rtimes \text{Id}_{\mathcal{C}}$ and $Q(\text{Id}_{\mathcal{C}}) = \mathfrak{Q}(\mathcal{C}) \rtimes \text{Id}_{\mathcal{C}}$. From here it follows that $D(\text{Id}_{\mathcal{C}}) = \mathfrak{D}(\mathcal{C})$ and similarly $Q(\text{Id}_{\mathcal{C}}) = \mathfrak{Q}(\mathcal{C})$. With these identifications established, we observe that any pivotal structure $\rho: \text{Id}_{\mathcal{C}} \rightarrow (-)^{\vee\vee}$ can be uniquely identified with a quasi-pivotal structure $(1, \rho)$. Due to Lemma 4.12, this corresponds to a module $(1, \vartheta_1)$ of $\mathfrak{Q}(\mathcal{C}): \mathcal{C} \rightarrow \mathcal{C}$. By Theorem 6.26 such a module exists if and only if $\mathfrak{D}(\mathcal{C})$ and $\mathfrak{Q}(\mathcal{C})$ are isomorphic as monads. \square

REFERENCES

- [AA17] Nicolás Andruskiewitsch and Iván Angiono. On finite dimensional Nichols algebras of diagonal type. *Bull. Math. Sci.*, 7(3):353–573, 2017.
- [AAGI⁺14] Nicolas Andruskiewitsch, Ivan Angiono, Augustin García Iglesias, Blas Torrecillas, and Cristian Vay. From Hopf algebras to tensor categories. In *Conformal field theories and tensor categories*, Math. Lect. Peking Univ., pages 1–31. Springer, Heidelberg, 2014.
- [AC12] Marcelo Aguiar and Stephen U. Chase. Generalized Hopf modules for bimonads. *Theory and Applications of Categories*, 27:263–326, 2012.
- [AM10] Marcelo Aguiar and Swapneel Mahajan. *Monoidal functors, species and Hopf algebras*, volume 29 of *CRM Monograph Series*. American Mathematical Society, Providence, RI, 2010. With forewords by Kenneth Brown and Stephen Chase and André Joyal.
- [ARS10] Nicolás Andruskiewitsch, David Radford, and Hans-Jürgen Schneider. Complete reducibility theorems for modules over pointed Hopf algebras. *Journal of Algebra*, 324(11):2932–2970, 2010.
- [AS98a] N. Andruskiewitsch and H.-J. Schneider. Lifting of quantum linear spaces and pointed Hopf algebras of order p^3 . *Journal of Algebra*, 209(2):658–691, 1998.
- [AS98b] Nicolás Andruskiewitsch and Hans-Jürgen Schneider. Hopf algebras of order p^2 and braided Hopf algebras of order p . *Journal of Algebra*, 199(2):430–454, 1998.
- [AS02] Nicolás Andruskiewitsch and Hans-Jürgen Schneider. Pointed Hopf algebras. In *New directions in Hopf algebras*, volume 43 of *Math. Sci. Res. Inst. Publ.*, pages 1–68. Cambridge Univ. Press, Cambridge, 2002.
- [BD95] John C. Baez and James Dolan. Higher-dimensional algebra and topological quantum field theory. *Journal of Mathematical Physics*, 36(11):6073–6105, 1995.
- [Bec69] Jon Beck. Distributive laws. In *Sem. on Triples and Categorical Homology Theory (ETH, Zürich, 1966/67)*, pages 119–140. Springer, Berlin, 1969.
- [Bén63] Jean Bénabou. Catégories avec multiplication. *Comptes Rendus Hebdomadaires des Séances de l’Académie des Sciences*, 256:1887–1890, 1963.
- [BLV11] Alain Bruguières, Steve Lack, and Alexis Virelizier. Hopf monads on monoidal categories. *Advances in Mathematics*, 227(2):745–800, 2011.
- [Boa95] J. Michael Boardman. Stable operations in generalized cohomology. In *Handbook of algebraic topology*, pages 585–686. North-Holland, Amsterdam, 1995.
- [Brz20] Tomasz Brzeziński. Trusses: paragons, ideals and modules. *Journal of Pure and Applied Algebra*, 224(6):106258, 39, 2020.
- [BS11a] John Baez and Mike Stay. Physics, topology, logic and computation: a Rosetta Stone. In *New structures for physics*, volume 813 of *Lecture Notes in Phys.*, pages 95–172. Springer, Heidelberg, 2011.
- [BS11b] Thomas Booker and Ross Street. Torsors, herds and flocks. *Journal of Algebra*, 330(1):346–374, 2011.
- [BV07] Alain Bruguières and Alexis Virelizier. Hopf monads. *Advances in Mathematics*, 215(2):679–733, 2007.
- [BV12] Alain Bruguières and Alexis Virelizier. Quantum double of Hopf monads and categorical centers. *Transactions of the American Mathematical Society*, 364(3):1225–1279, 2012.
- [BW99] John W. Barrett and Bruce W. Westbury. Spherical categories. *Advances in Mathematics*, 143(2):357–375, 1999.
- [Cer43] Jeremiah Certaine. The ternary operation $(abc) = ab^{-1}c$ of a group. *Bulletin of the American Mathematical Society*, 49:869–877, 1943.
- [CF94] Louis Crane and Igor B. Frenkel. Four-dimensional topological quantum field theory, Hopf categories, and the canonical bases. *Journal of Mathematical Physics*, 35(10):5136–5154, 1994.
- [CM99] Alain Connes and Henri Moscovici. Cyclic cohomology and Hopf algebras. *Letters in Mathematical Physics*, 48(1):97–108, 1999. Moshé Flato (1937–1998).
- [CM00] Alain Connes and Henri Moscovici. Cyclic cohomology and Hopf algebra symmetry. *Letters in Mathematical Physics*, 52(1):1–28, 2000. Conference Moshé Flato 1999 (Dijon).

- [DP80] Albrecht Dold and Dieter Puppe. Duality, trace, and transfer. In *Proceedings of the International Conference on Geometric Topology (Warsaw, 1978)*, pages 81–102. PWN, Warsaw, 1980.
- [Dri87] V. G. Drinfeld. Quantum groups. *Proc. Int. Congr. Math., Berkeley/Calif. 1986, Vol. 1*, 798–820 (1987)., 1987.
- [DS07] Brian Day and Ross Street. Centres of monoidal categories of functors. In *Categories in algebra, geometry and mathematical physics*, volume 431 of *Contemp. Math.*, pages 187–202. Amer. Math. Soc., Providence, RI, 2007.
- [DSS21] Christopher L. Douglas, Christopher Schommer-Pries, and Noah Snyder. *Dualizable tensor categories*, volume 1308. Providence, RI: American Mathematical Society (AMS), 2021.
- [EGNO15] Pavel Etingof, Shlomo Gelaki, Dmitri Nikshych, and Victor Ostrik. *Tensor categories*, volume 205 of *Mathematical Surveys and Monographs*. American Mathematical Society, Providence, RI, 2015.
- [EK66] Samuel Eilenberg and G. Max Kelly. Closed categories. In *Proc. Conf. Categorical Algebra (La Jolla, Calif., 1965)*, pages 421–562. Springer, New York, 1966.
- [ENO04] Pavel Etingof, Dmitri Nikshych, and Viktor Ostrik. An analogue of Radford’s s^4 formula for finite tensor categories. *IMRN. International Mathematics Research Notices*, 2004(54):2915–2933, 2004.
- [ESZ21] Mohamed Elhamdadi, Masahico Saito, and Emanuele Zappala. Heap and ternary self-distributive cohomology. *Communications in Algebra*, 49(6):2378–2401, 2021.
- [FS03] Jürgen Fuchs and Christoph Schweigert. Category theory for conformal boundary conditions. In *Vertex operator algebras in mathematics and physics. Proceedings of the workshop, Fields Institute for Research in Mathematical Sciences, Toronto, Canada, October 23–27, 2000*, pages 25–70. Providence, RI: American Mathematical Society (AMS), 2003.
- [FSS17] Jürgen Fuchs, Gregor Schaumann, and Christoph Schweigert. A trace for bimodule categories. *Applied Categorical Structures*, 25(2):227–268, 2017.
- [GNN09] Shlomo Gelaki, Deepak Naidu, and Dmitri Nikshych. Centers of graded fusion categories. *Algebra & Number Theory*, 3(8):959–990, 2009.
- [GR20] Azat M. Gainutdinov and Ingo Runkel. Projective objects and the modified trace in factorisable finite tensor categories. *Compositio Mathematica*, 156(4):770–821, 2020.
- [Gre10] Justin Greenough. Monoidal 2-structure of bimodule categories. *Journal of Algebra*, 324(8):1818–1859, 2010.
- [Hal21] Sebastian Halbig. Generalized Taft algebras and pairs in involution. *Communications in Algebra*, 49(12):5181–5195, 2021.
- [Hec07] István Heckenberger. Examples of finite-dimensional rank 2 Nichols algebras of diagonal type. *Compos. Math.*, 143(1):165–190, 2007.
- [Hec09] István Heckenberger. Classification of arithmetic root systems. *Adv. Math.*, 220(1):59–124, 2009.
- [HK19] Sebastian Halbig and Ulrich Krähmer. A Hopf algebra without a modular pair in involution. In *Geometric methods in physics XXXVII*, Trends Math., pages 140–142. Birkhäuser/Springer, Cham, 2019.
- [HKRS04a] Piotr M. Hajac, Masoud Khalkhali, Bahram Rangipour, and Yorck Sommerhäuser. Hopf-cyclic homology and cohomology with coefficients. *Comptes Rendus Mathématique. Académie des Sciences. Paris*, 338(9):667–672, 2004.
- [HKRS04b] Piotr M. Hajac, Masoud Khalkhali, Bahram Rangipour, and Yorck Sommerhäuser. Stable anti-Yetter–Drinfeld modules. *Comptes Rendus Mathématique. Académie des Sciences. Paris*, 338(8):587–590, 2004.
- [HKS19] Mohammad Hassanzadeh, Masoud Khalkhali, and Ilya Shapiro. Monoidal categories, 2-traces, and cyclic cohomology. *Canadian Mathematical Bulletin. Bulletin Canadien de Mathématiques*, 62(2):293–312, 2019.
- [HL17] Christopher D. Hollings and Mark V. Lawson. *Wagner’s theory of generalised heaps*. Springer, Cham, 2017.
- [HPT16] André Henriques, David Penneys, and James Tener. Categorified trace for module tensor categories over braided tensor categories. *Documenta Mathematica*, 21:1089–1149, 2016.

- [HS10] Piotr M. Hajac and Yorck Sommerhäuser. Anti-Yetter–Drinfel’d Modules in Cyclic Cohomology. *privately communicated*, 2010.
- [HY10] I. Heckenberger and H. Yamane. Drinfel’d doubles and Shapovalov determinants. *Revista de la Unión Matemática Argentina*, 51(2):107–146, 2010.
- [HZ22] Sebastian Halbig and Tony Zorman. Pivotality, twisted centres and the anti-double of a Hopf monad. (*preprint*) *arXiv:2201.05361*, January 2022.
- [JS91] André Joyal and Ross Street. Tortile Yang-Baxter operators in tensor categories. *Journal of Pure and Applied Algebra*, 71(1):43–51, 1991.
- [JS93] André Joyal and Ross Street. Braided tensor categories. *Advances in Mathematics*, 102(1):20–78, 1993.
- [Kas95] Christian Kassel. *Quantum groups*, volume 155 of *Graduate Texts in Mathematics*. Springer-Verlag, New York, 1995.
- [KK11] Niels Kowalzig and Ulrich Krähmer. Cyclic structures in algebraic (co)homology theories. *Homology, Homotopy and Applications*, 13(1):297–318, 2011.
- [KL01] Thomas Kerler and Volodymyr V. Lyubashenko. *Non-semisimple topological quantum field theories for 3-manifolds with corners*, volume 1765 of *Lecture Notes in Mathematics*. Springer-Verlag, Berlin, 2001.
- [Kow20] Niels Kowalzig. Centres, trace functors, and cyclic cohomology. (*preprint*) <http://arxiv.org/pdf/2012.13790v1>, December 2020.
- [KR93] Louis H. Kauffman and David E. Radford. A necessary and sufficient condition for a finite-dimensional Drinfel’d double to be a ribbon Hopf algebra. *Journal of Algebra*, 159(1):98–114, 1993.
- [Kre49] M. Krejn. Das Dualitätssprinzip für eine bikompakte Gruppe und eine quadratische Block-Algebra. *Doklady Akademii Nauk SSSR. Novaya Seriya*, 69:725–728, 1949.
- [KS19] Ivan Kobyzev and Ilya Shapiro. A categorical approach to cyclic cohomology of quasi-Hopf algebras and Hopf algebroids. *Applied Categorical Structures*, 27(1):85–109, 2019.
- [Lei14] Tom Leinster. *Basic category theory*, volume 143 of *Cambridge Studies in Advanced Mathematics*. Cambridge University Press, Cambridge, 2014.
- [Lor21] Fosco Loregian. *(Co)end calculus*, volume 468 of *London Mathematical Society Lecture Note Series*. Cambridge University Press, Cambridge, 2021.
- [LS69] R. G. Larson and M. E. Sweedler. An associative orthogonal bilinear form for Hopf algebras. *American Journal of Mathematics*, 91:75–94, 1969.
- [Lus90] George Lusztig. Finite dimensional Hopf algebras arising from quantized universal enveloping algebras. *Journal of the American Mathematical Society*, 3(1):257–296, 1990.
- [Maj91] Shahn Majid. Representations, duals and quantum doubles of monoidal categories. In *Proceedings of the winter school on geometry and physics, held in Srni, Czechoslovakia, 6-13 January, 1990*, pages 197–206. Palermo: Circolo Matematico di Palermo, 1991.
- [Maj94] Shahn Majid. Cross products by braided groups and bosonization. *Journal of Algebra*, 163(1):165–190, 1994.
- [Man87] Yu. I. Manin. Some remarks on Koszul algebras and quantum groups. *Annales de l’Institut Fourier*, 37(4):191–205, 1987.
- [May01] Jon Peter May. Picard groups, Grothendieck rings, and Burnside rings of categories. *Advances in Mathematics*, 163(1):1–16, 2001.
- [McC02] Paddy McCrudden. Opmonoidal monads. *Theory and Applications of Categories*, 10:No. 19, 469–485, 2002.
- [ML63] Saunders Mac Lane. Natural associativity and commutativity. *Rice University Studies*, 49(4):28–46, 1963.
- [ML98] Saunders Mac Lane. *Categories for the working mathematician*, volume 5 of *Graduate Texts in Mathematics*. Springer-Verlag, New York, second edition, 1998.
- [Moe02] Ieke Moerdijk. Monads on tensor categories. *J. Pure Appl. Algebra*, 168(2-3):189–208, 2002. Category theory 1999 (Coimbra).
- [Mon93] Susan Montgomery. *Hopf algebras and their actions on rings*, volume 82 of *CBMS Regional Conference Series in Mathematics*. Published for the Conference Board of the Mathematical Sciences, Washington, DC; by the American Mathematical Society, Providence, RI, 1993.

- [Müg13] Michael Müger. *Quantum physics and linguistics: a compositional, diagrammatic discourse*, chapter Chapter 6. Oxford University Press, 2013.
- [MW11] Bachuki Mesablishvili and Robert Wisbauer. Bimonads and Hopf monads on categories. *Journal of K-Theory. K-Theory and its Applications in Algebra, Geometry, Analysis & Topology*, 7(2):349–388, 2011.
- [Nen04] Adriana Nenciu. Quasitriangular pointed Hopf algebras constructed by Ore extensions. *Algebr. Represent. Theory*, 7(2):159–172, 2004.
- [NS07] Siu-Hung Ng and Peter Schauenburg. Higher Frobenius-Schur indicators for pivotal categories. In *Hopf algebras and generalizations*, volume 441 of *Contemp. Math.*, pages 63–90. Amer. Math. Soc., Providence, RI, 2007.
- [NZ89] Warren D. Nichols and M. Bettina Zoeller. A Hopf algebra freeness theorem. *American Journal of Mathematics*, 111(2):381–385, 1989.
- [Ost03] Victor Ostrik. Module categories, weak Hopf algebras and modular invariants. *Transformation Groups*, 8(2):177–206, 2003.
- [Prü24] Heinz Prüfer. Theorie der Abelschen Gruppen. *Mathematische Zeitschrift*, 20(1):165–187, 1924.
- [Rad76] David E. Radford. The order of the antipode of a finite dimensional Hopf algebra is finite. *American Journal of Mathematics*, 98(2):333–355, 1976.
- [Rad85] David E. Radford. The structure of Hopf algebras with a projection. *Journal of Algebra*, 92:322–347, 1985.
- [Rad93] David E. Radford. Minimal quasitriangular Hopf algebras. *Journal of Algebra*, 157(2):285–315, 1993.
- [Rad12] David E. Radford. *Hopf algebras*, volume 49 of *Series on Knots and Everything*. World Scientific Publishing Co. Pte. Ltd., Hackensack, NJ, 2012.
- [Rie17] Emily Riehl. *Category theory in context*. Courier Dover Publications, 2017.
- [RT90] N. Yu. Reshetikhin and V. G. Turaev. Ribbon graphs and their invariants derived from quantum groups. *Communications in Mathematical Physics*, 127(1):1–26, 1990.
- [Sch92] Peter Schauenburg. *Tannaka duality for arbitrary Hopf algebras*. München: R. Fischer, 1992.
- [Sch01] Peter Schauenburg. Turning monoidal categories into strict ones. *New York Journal of Mathematics*, 7:257–265, 2001.
- [Sel11] Peter Selinger. A survey of graphical languages for monoidal categories. In *New structures for physics*, volume 813 of *Lecture Notes in Phys.*, pages 289–355. Springer, Heidelberg, 2011.
- [Shi15] Kenichi Shimizu. The pivotal cover and Frobenius-Schur indicators. *Journal of Algebra*, 428:357–402, 2015.
- [Shi16] Kenichi Shimizu. Pivotal structures of the Drinfeld center of a finite tensor category. (preprint) *arXiv:1608.05905*, August 2016.
- [Shi17] Kenichi Shimizu. The monoidal center and the character algebra. *Journal of Pure and Applied Algebra*, 221(9):2338–2371, 2017.
- [Shi19] Kenichi Shimizu. Non-degeneracy conditions for braided finite tensor categories. *Advances in Mathematics*, 355:36, 2019. Id/No 106778.
- [Ško07] Zoran Škoda. Quantum heaps, cops and heapy categories. *Mathematical Communications*, 12(1):1–9, 2007.
- [Str72] Ross Street. The formal theory of monads. *Journal of Pure and Applied Algebra*, 2(2):149–168, 1972.
- [Str12] Ross Street. Monoidal categories in, and linking, geometry and algebra. *Bulletin of the Belgian Mathematical Society. Simon Stevin*, 19(5):769–821, 2012.
- [Szl03] Kornél Szlachányi. The monoidal Eilenberg-Moore construction and bialgebroids. *Journal of Pure and Applied Algebra*, 182(2-3):287–315, 2003.
- [Szl12] Kornél Szlachányi. Skew-monoidal categories and bialgebroids. *Advances in Mathematics*, 231(3-4):1694–1730, 2012.
- [Tan38] T. Tannaka. Über den Dualitätssatz der nichtkommutativen topologischen Gruppen. *Tohoku Mathematical Journal*, 45:1–12, 1938.
- [Tur88] V. G. Turaev. The Yang-Baxter equation and invariants of links. *Inventiones Mathematicae*, 92(3):527–553, 1988.
- [TV17] Vladimir Turaev and Alexis Virelizier. *Monoidal categories and topological field theory*, volume 322 of *Progress in Mathematics*. Birkhäuser/Springer, Cham, 2017.

- [Ulb90] K.-H. Ulbrich. On Hopf algebras and rigid monoidal categories. *Israel Journal of Mathematics*, 72(1-2):252–256, 1990.
- [Wil08] Simon Willerton. A diagrammatic approach to Hopf monads. *The Arabian Journal for Science and Engineering. Section C. Theme Issues*, July 2008.

ERKLÄRUNG

Die hier vorliegende Promotion wurde an der Technischen Universität Dresden unter der Betreuung von Prof. Dr. Ulrich Krähmer angefertigt.

Hiermit versichere ich, dass ich die vorliegende Arbeit ohne unzulässige Hilfe Dritter und ohne Benutzung anderer als der angegebenen Hilfsmittel angefertigt habe; die aus fremden Quellen direkt oder indirekt übernommenen Gedanken sind als solche kenntlich gemacht. Die Arbeit wurde bisher weder im Inland noch im Ausland in gleicher oder ähnlicher Form einer anderen Prüfungsbehörde vorgelegt.

Ort und Datum

Unterschrift