

On-line method for optimal tuning of PID controllers using standard OPC interface

Método on-line para sintonización óptima de controladores PID utilizando interface estándar OPC

DOI: <http://doi.org/10.17981/ingecuc.18.2.2022.02>

Artículo de Investigación Científica. Fecha de Recepción: 16/11/2019, Fecha de Aceptación: 21/08/2022

Cristhian Ivan Riaño Jaimes 

Universidad de Pamplona. Norte de Santander, (Colombia)

cristhian.riano@unipamplona.edu.co

Jorge Luis Díaz Rodríguez 

Universidad de Pamplona. Norte de Santander, (Colombia)

jdiazcu@gmail.com

Diego Armando Mejía Bugallo 

Universidad de Pamplona. Norte de Santander, (Colombia)

diego.mejia@unipamplona.edu.co

To cite this paper:

C. Riaño Jaimes, J. Díaz Rodríguez, D. Mejía Bugallo, “On-line method for optimal tuning of PID controllers using standard OPC interface”. DOI: <http://doi.org/10.17981/ingecuc.18.2.2022.02>

Resumen

Introducción– El controlado PID es el algoritmo matemático mayormente utilizado como estrategia de control regulatorio en entornos industriales. Las aplicaciones son variadas; sin embargo, su respuesta depende del cálculo adecuado de sus tres parámetros: el proporcional, el derivativo y el integral. La sintonización analítica y algunos métodos experimentales resuelven el problema, pero ahora, dentro del contexto digital y de integración de procesos se habilitan nuevas posibilidades de sintonización.

Objetivo– Obtener de manera automática y remota los parámetros óptimos del controlador PID aprovechando una conexión online vía el protocolo de comunicación OPC para analizar la respuesta transitoria del sistema.

Metodología– El estudio se realiza en tres grandes fases, se inicia con un proceso térmico PD3 SMAR con conexión vía OPC, en esta fase se construye analíticamente el modelo matemático del proceso basado en leyes fundamentales. En la segunda fase utilizando un método analítico de sintonización se crea la arquitectura de control PID sobre la cual se realiza la experimentación online. En la tercera fase se implementan los algoritmos genéticos para sintonización automática, extrayendo medidas de rendimiento del controlador PID a través de la respuesta transitorio del proceso y se determinan de manera óptima los valores para los parámetros proporcional, derivativo e integral.

Resultados– El método de sintonización automática fue probado con dos procesos industriales correctamente instrumentados y se puede observar el potencial de aplicación por su buen resultado además de que no se requiere de conocimientos matemáticos

© The author; licensee Universidad de la Costa - CUC.

INGE CUC Vol. 18. No. 2, Julio – Diciembre, 2022.

Barranquilla. ISSN 0122-6517 Impreso, ISSN 2382-4700 Online

específicos en comparación con métodos convencionales de sintonización.

Conclusiones– El método de sintonización automática consigue ser empleado de forma remota para calcular los parámetros óptimos de un controlador PID. Los parámetros son calculados a partir de la respuesta transitoria y de la definición de unos criterios de diseño adaptables a cualquier necesidad de control, de respuesta y de proceso.

Palabras clave– Algoritmos genéticos; Sintonización automática; Optimización; Controlador PID;

Abstract

Introduction– The controlled PID is the most widely used mathematical algorithm as a regulatory control strategy in industrial environments. The applications are varied; however, its answer depends on the proper calculation of its three parameters: the proportional, the derivative, and the integral. Analytical tuning and experimental methods solve the problem, but new tuning possibilities are now enabled within the digital and process integration context.

Objective– Automatically and remotely obtain the optimal parameters of the PID controller, taking advantage of an online connection via the OPC communication protocol to analyze the transient response of the system.

Methodology– The study is carried out in three main phases; it begins with a PD3 SMAR thermal process with connection via OPC; in this phase, the mathematical model of the process is built analytically based on fundamental laws. In the second phase, using an analytical tuning method, the PID control architecture is created on which the online experimentation is carried out. In the third phase, the genetic algorithms for automatic tuning are implemented, extracting performance measures from the PID controller through the transient response of the process and optimally determining the values for the proportional, derivative, and integral parameters.

Results– The automatic tuning method was tested with two properly instrumented industrial processes. The potential for application can be seen due to its good result and because it does not require specific mathematical knowledge compared to conventional tuning methods.

Conclusions– The automatic tuning method can be used remotely to calculate the optimal parameters of a PID controller. The parameters are calculated from the transient response and the definition of design criteria adaptable to any need for control, response, and process.

Keywords– Genetic algorithms; Automatic tuning; Optimization; PID controller;

I. INTRODUCTION

In-process control theory, developing new control strategies applicable to different systems is essential in academic and industrial fields. Within an analytical context, knowledge about the process allows the creation of mathematical models that enable experimentation in simulation environments, leading to answers about dynamic behavior, especially the generation of new control strategies [1]. PID controllers, considered conventional controls, remain in full force and are the types of control most used in industrial environments [2]. The simple structure makes them easy to implement on different devices. The performance characteristics of the PID controller are constantly tested and prove that the controller robustly performs its function for different operating conditions and in a wide range of applications [3].

A PID controller defines its behavior through three proportional, integral, and derivative components concerning its mathematical structure that contribute to the error minimization process [4]. The error enters the controller with the information resulting from the algebraic difference between the reference and current values [5]. The proportional component generates a controller response proportional to the magnitude of the error. The integral part operates with the data over time and, based on this behavior, generates a corrective action to reduce the displacement of the process variable. The derivative component observes the rate of change of the controlled variable and helps reduce significant variations in the behavior of the controlled variable [6]. Each proportional, integral, and derivative action is represented by a numerical value that defines the quality with which the controller fits the purpose of controlling a process [7]. This simple implementation has led to PID controllers being the most widely used in industrial processes. Controller performance is the subject of multiple investigations covering different areas pursuing this purpose [8]. Modern applications continue to use this mathematical structure implemented as an algorithm in embedded devices with a control instrument, making it pertinent to the search for new strategies that improve the controller's performance [9].

The PID controller consists of adjustment parameters called proportional action, Integral action, and derivative action. The literature describes that most tuning techniques involve Ziegler-Nichols PID tuning parameters [10]. By adjusting the three parameters of the PID controller, the controller can provide a control action designed to meet particular design specifications. Controller response can be described as the controller's transient response performance against an error, the degree to which the controller overshoots the setpoint, and the degree of system oscillation [11]. Please note that using the PID algorithm for control does not guarantee optimal system control or system stability. Various techniques are derived from its simple mathematics, and multiple lines of research seek solutions to configure, parameterize and develop strategies that enhance its response characteristics [12].

If the current context is observed, where the digital age is advancing, interoperability and integration barriers still prevent several technological and academic developments from being assumed and directly linked to industrial processes. Industrial communication protocols enable bidirectional communication to receive process information and access configuration parameters [13]. New emerging approaches relate to supervisory systems to create digital twins of processes that share the exact characteristics of natural processes [14].

Modeling and simulation are essential tools for answering the systems under investigation. Simulation environments allow the behavior of the most common systems in the industry to be observed in a safe environment. Mathematical modeling uses the fundamental laws to represent the system's dynamic behavior that will be considered in the development of the investigation [15]. Through these tools, continuous processes can be understood, and the mathematical model becomes a decisive element in decision making. The development of algorithms not only for the areas of control but also for supervision and system operation is driven by the possibility of first interacting with models of physical processes to be validated and implemented later [16].

Academic centers make different efforts to find strategies for automatic and remote tuning. The performance of the controllers within the process represents a long-term positive effect on the use of available resources [17]. Evolutionary algorithms based on intelligent techniques constitute robust tools to obtain the best performance from control systems [18]. The objective function represents an adequate mechanism to drive the results to obtain a response that adapts to the specific needs of each project. The PID controller supported by new techniques continues to remain in force, with its industrial use predominating due to the reliability it represents [19].

Knowing the dynamics of the process observing and interacting with the plant facilitated the construction of the mathematical model for the temperature and water mixing processes. The mathematical model incorporated in a simulation environment created the necessary conditions for experimentation. To implement the online tuning, an OPC server client was used, extracting in real-time all the process variables needed for the design and operation of the PID controller in the process. The bidirectional communication and the possibility of writing and reading values of the instrumentation installed in the process enables the opportunity of interacting and altering the dynamic behavior of the process remotely. The development of an automatic tuning method using current values of the process led to the implementation of genetic algorithms that facilitate the search process having as reference a transient response of the process. The search method is relatively fast, performed on the mathematical model adjusted to the natural behavior of the process, considering it as a digital twin of the natural process. The values returned as optimal in the search process are written in the control units and tested in the natural process. The results obtained make the method viable within the architecture built for its development. This article exposes the path to developing a PID controller's automatic and remote tuning using genetic algorithms.

II. METHODOLOGY

The plant presented in the Figure 1 comprises a circuit that interconnects three tanks. The heating tank contains two 4KW electrical resistors manipulated by PWM, in charge of transferring heat to the liquid inside the tank. The mathematical model and the temperature control strategy presented in this document are carried out for the heating tank using the current flowing through the electrical resistors as a manipulated variable. The system has a reservoir tank that allows receiving and delivering the liquid back to the process. A temperature controller was also tuned for the mixing tank, following the same strategy presented in this article. The entire system is interconnected and enabled for SCADA control through a Foundation Fieldbus network.

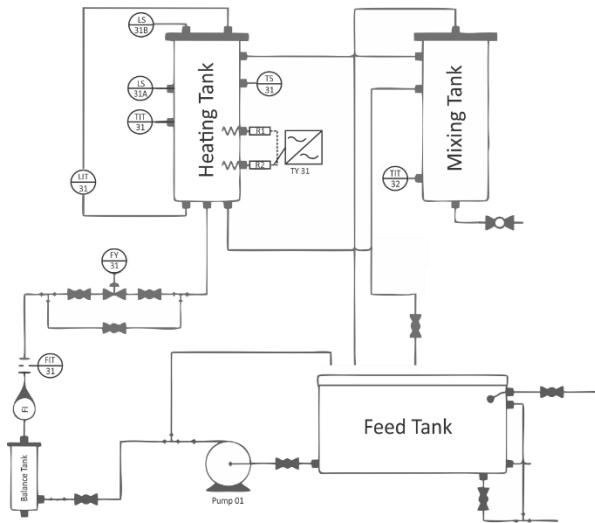

Instrumentation used in process control	
Name	Description
FIT-31	Flow Transmitter Sensor
TIT-31	Sensor Transmitter Temperature Indicator
LIT-31	Temperature Indicator Transmitter
FCV-31	Flow Control Valve
TY-31	Thermal Resistance
LS-31A	Switch level
FY-31	Relay Flow

Figure 1 P&I Diagram and instrumentation used in process control. Source: authors

A. Thermal process description

The general configuration of the SMAR didactic plant was modified to achieve the implementation of control architectures to create study and verification environments in the laboratory. The plant is made up of three tanks, tank one is for heating, and tank two is for mixing, both of which have the exact dimensions. Tank three has the storage function and provides tanks one and two water through a three-phase pump. Through the force of gravity, Tank two returns the water to tank three. Therefore, tank two always remains full and is where the mixing process occurs. Tank one has a 4- kW resistance controlled by pulse-width modulation (PWM) as a coupled actuator; it acts as a manipulated variable in the temperature process control.

The SMAR didactic plant has different communication alternatives, facilitating the monitoring of operating parameters and variables. Technologies available for communication include industrial Hart, Foundation Fieldbus, and Profibus protocols. The plant is put into operation in an automatic operational mode, sharing data and control configuration information and dynamic process response. In each function, the process is monitored digitally, allowing the collection of operating data, sensors, and actuators. These collected data are sent via OLE for Process Control (OPC), a communication standard with an open client-server architecture. The OPC server is the data source, and any application in our case, the Matlab software accesses the server to read write any available variables.

Figure 2 shows the architecture configured for automatic operation and control of the process. The distributed control system coordinates the execution, makes available the current value of each of the variables involved in the system, and shows the status of the process in real-time. This system can access the configuration parameters of the DF75 HSE Controller, especially the configuration parameters of the PID controller. OPC Server services, connection through the Foundation Fieldbus (SCADA) network, support the process and monitor the system in real-time, with all information accessible. An OPC client is installed on a remote computer system to capture and process the variables. Both plant modeling, control techniques, and automatic tuning methods are performed in this system. The primary tool used in this study is the Matlab software.

B. Mathematical modeling of heating processes

With the in-depth study of the operating dynamics, it is possible to present the mathematical model in the form of differential equations that describe the execution characteristics of the loops. In the construction of the

model that represents the dynamic behavior of the heating process given in the tank, the following considerations were assumed:

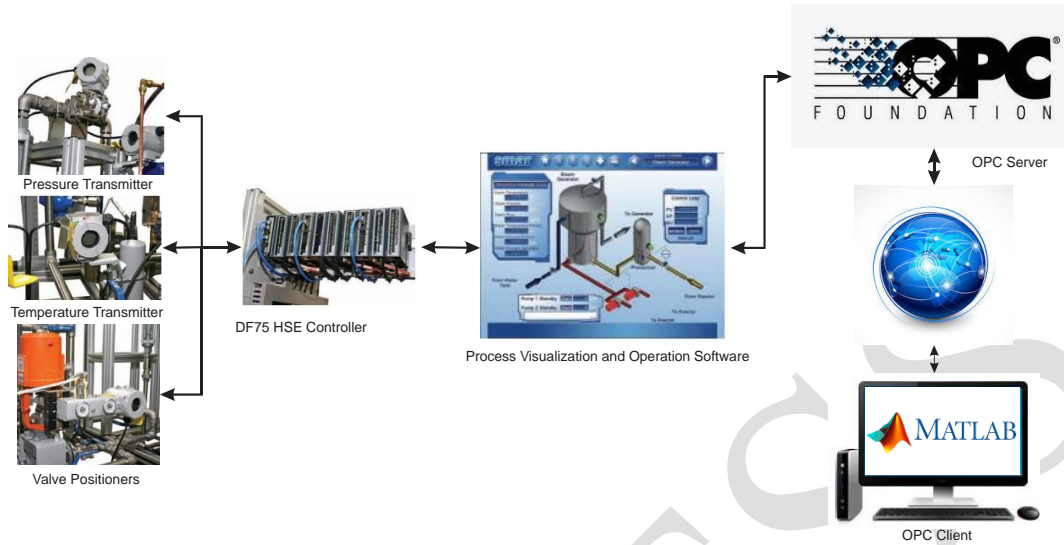

Figure 2. Architecture configured for automatic operation and control of the process. Source: authors

- Water inlet is defined as a constant flow in the model, with the operating point for valve opening at ten percent.
- Water inlet temperature is constant.
- The operating point is defined based on the criterion that the lowest inflow of ambient temperature water and the temperature differential inside the tank will be smaller, which will cause a quick response to changes in the reference.
- The process does not lose or gain mass.
- The hot water flow in the heating tank is constant.
- The work done with the pumps for the water inlet in each of the processes is the same work done to cause the water to leave the system, so the work based on this premise is not considered to simplify the model.
- The energy acquired by the system due to the movement of the liquid and its velocity is equal to the energy acquired by the system due to the position of the gravitational field.

The differential equations that emulate the dynamic behavior of the heating process are obtained by applying the principle of conservation of energy and mass. Therefore, we have a sequence in the rate of conservation of mass, which is the rate of mass entering the system minus the rate leaving the system equals the cumulative rate of change in the system. Also, within the same logic, we have the principle conservation of energy with the first law of thermodynamics, where the flow of incoming internal, kinetic, and potential energy minus the flow of outgoing energy plus the heat added to the system by conduction and radiation minus the work done by the system is equal to the rate of change of the internal, kinetic, and potential energy within the system. Equation 1 shows the balance of mass and energy applied in constructing the dynamic model.

$$\widehat{M}_i - \widehat{M}_o - \widehat{M}_G - \widehat{M}_C = \widehat{M} \quad (1)$$

Where,

M_i : Mass in through system Boundaries.

M_o : Mass out through system boundaries.

M_G : Mass generated within system.

M_C : Mass consumed within system.

\widehat{M} : Mass accumulated within system.

The masses generated within the system as the masses consumed within the system are omitted in the equation of following the premises mentioned above.

$$\widehat{M}_i - \widehat{M}_o = \widehat{M} \quad (2)$$

(3). Both the mass in through system boundaries and mass out through system boundaries are determined by

$$\widehat{M}_i = m_i = F_i \cdot \rho \quad (3)$$

Where,

F_i : Input flux given in $\left(\frac{m^3}{seg}\right)$

ρ : Density of water given in $\left(\frac{Kg}{m^3}\right)$

m_i, m_o : Mass flow (input and output) given in $\left(\frac{Kg}{seg}\right)$

The applied mass balance in tank one is given by (4).

$$\frac{dM_{TK1}}{dt} = m_i - m_o = F_i \cdot \rho - F_o \cdot \rho \quad (4)$$

As the tank's body is volumetric, the mass differentials dM_{TK1} into which we divide it are associated with volume differentials $\rho \frac{dV}{dt} = \frac{dM_{TK1}}{dt}$, where ρ is the volumetric density (mass per unit volume). Therefore, equation (5) is obtained.

$$\rho \frac{dV}{dt} = m_i - m_o = F_i \cdot \rho - F_o \cdot \rho \quad (5)$$

Since the tank's volume is constant over time, it is stated that the inlet flow is equal to the outlet flow at a steady state ($F_i = F_o$). The energy balance is based on the law of conservation of energy. The energy in through system boundaries minus the energy out through system boundaries equals the energy accumulated within the system. The law of conservation of energy is applied in (6).

$$\widehat{E}_i - \widehat{E}_o = \widehat{E} \quad (6)$$

Where,

E_i : Energy in through system Boundaries.

E_o : Energy out through system boundaries.

\widehat{E} : Energy accumulated within system.

The total energy per unit mass θ of a fluid flowing into or out of a control object volume would be given by $\theta = P \cdot v + u + e_k + e_p$. The total energy carried by a mass m , is simply the product $Em=m\theta$, provided the properties of the mass are uniform. The total energy flux carried by mass $Emasa$ would then be $m\theta$.

$$\widehat{E}_i = m \frac{dE}{dt} = m_i \cdot (U + e_k + e_p + P \cdot v)_{in} - m_o \cdot (U + e_k + e_p + P \cdot v)_{out} + Q + W_s \quad (7)$$

Where,

U : Internal energy

e_k : Kinetic energy

e_p : Potential energy

P : System pressure

v : System volume

The Q is the energy transferred to the system minus the energy lost by the system, $Q = Q_{elect} - Q_{perd}$ and W_s is the work done by moving parts in the system. In this model, W_s is related to the energy required. To bring water into the system and the momentum, it causes the water outlet of the system. The kinetic and potential energy is depreciated in the system to simplify the model $e_k = e_p = 0$. Rewriting the energy balance (7), it follows:

$$m \frac{dU}{dt} = m_i \cdot (U + P \cdot v)_{in} - m_o \cdot (U + P \cdot v)_{out} + Q_{elect} - Q_{perd} \quad (8)$$

Enthalpy defines the amount of energy in a system capable of doing work, so the pressure transfer is constant, and the enthalpy change is equal to the heat absorbed or released in the process. Enthalpy (H) is defined

© The author; licensee Universidad de la Costa - CUC.

INGE CUC Vol. 18. No. 2, Julio – Diciembre, 2022.

Barranquilla. ISSN 0122-6517 Impreso, ISSN 2382-4700 Online

as the thermal energy combination $H = U + \rho \cdot V$, then $\frac{dU}{dt} = \frac{dH}{dt} - \rho \cdot \frac{dV}{dt}$, So, rewriting (8), we have:

$$m \frac{dH}{dt} = m_i \cdot H_i - m_o \cdot H_o + Q_{elect} - Q_{perd} \quad (9)$$

Therefore, the enthalpy relative to a reference temperature, with the heat capacity, at constant pressure, $H = C_p(T - T_{ref})$, then $\frac{dH}{dt} = C_p \frac{dT}{dt} - C_p \frac{dT_{ref}}{dt}$ allows us to rewrite (9).

$$m \cdot C_p \frac{dT}{dt} = m_i \cdot C_p(T_i - T_{ref}) - m_o \cdot C_p(T - T_{ref}) + Q_{elect} - Q_{perd} \quad (10)$$

Including the definition of mass flow ($m_i = F_i \rho$, and $m_o = F_o \rho$) in the equation gives (11).

$$m \cdot C_p \frac{dT}{dt} = F_i \rho \cdot C_p(T_i - T_{ref}) - F_o \rho \cdot C_p(T - T_{ref}) + Q_{elect} - Q_{perd} \quad (11)$$

The electrical heat lost is calculated based on the heat transfer coefficient given by $Q_{perd} = \alpha_{isol} \Delta T$ and $Q_{elet} = U \cdot \Delta T_A$ to obtain the arithmetic mean of the temperature, as the same and constant, the equation is used $\Delta T_A = \frac{2 \cdot T_{ref} - (T_i + T)}{2}$, and $C_{A.Inox} \frac{dT}{dt} = -\alpha_{isol} \cdot (T - T_{amb})$, allows us to rewrite (11).

$$\rho \cdot V \cdot C_p \frac{dT}{dt} = F_i \rho \cdot C_p(T_i - T_{ref}) - F_o \rho \cdot C_p(T - T_{ref}) + U_{elect} \cdot \left(\frac{2 \cdot T_{ref} - (T_i + T)}{2} \right) - C_{A.Inox} \frac{dT}{dt} \quad (12)$$

C. validation of the mathematical model

In checking the mathematical model derived for the dynamic system of the heating process, it was necessary to use a simulation environment. The appropriate environment for model simulation is provided by the software Simulink MATLAB®. The Simulink Matlab S-Function block contains a framework to include continuous, discrete, and hybrid systems; it was used to include under a predefined syntax the mathematical model for the heating tank and use it as a block in different functions. The model is organized by identifying the mathematical relationship between the block's input, states, and outputs, structuring the mathematical model in parts such as initialization, update, derivatives, outputs, and completion. The created S-function block and the actual values for the parameters included in the mathematical model are presented in Figure 3.

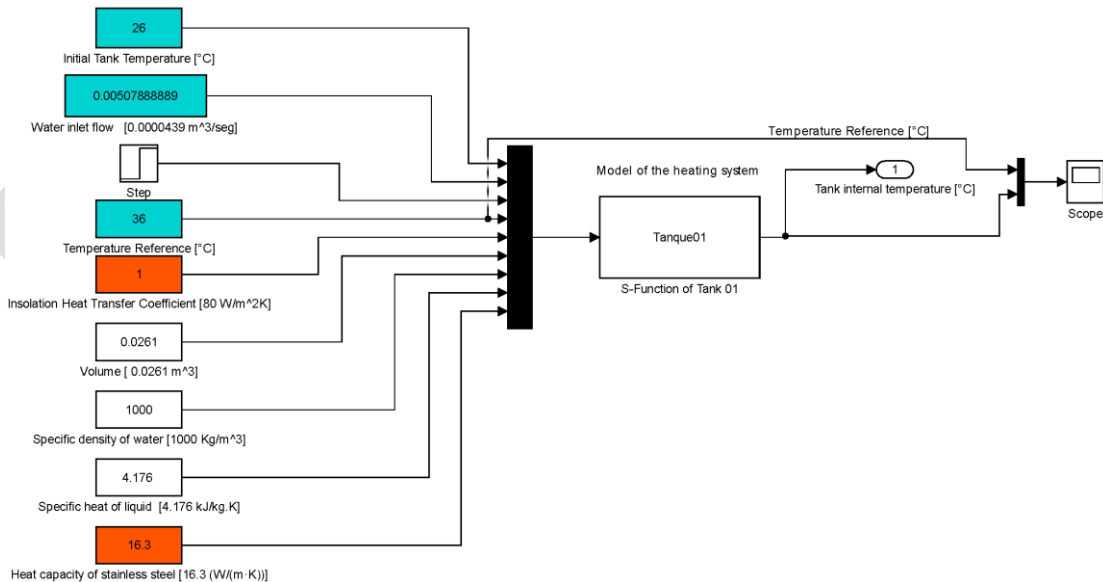

Figure 3 The S-function block with the mathematical model of the heating system. Source: authors.

Figure 4 shows the response of both the mathematical model simulated against a step input and the

© The author; licensee Universidad de la Costa - CUC.

INGE CUC Vol. 18, No. 2, Julio – Diciembre, 2022.

Barranquilla. ISSN 0122-6517 Impreso, ISSN 2382-4700 Online

system's response, both without any active control strategy. The answers obtained are similar; the response of the mathematical model with the adjusted parameters dynamically coincides with the actual behavior. The actual response is captured through the OPC client available in Matlab, allowing real-time access to the operational data. It was necessary to adjust the transfer coefficient in the simulation to obtain a better response than the real one. It is essential to ensure that the simulated model is very close to the actual system, as it will influence the quality of the controller. The model is considered reasonably suitable for the control design.

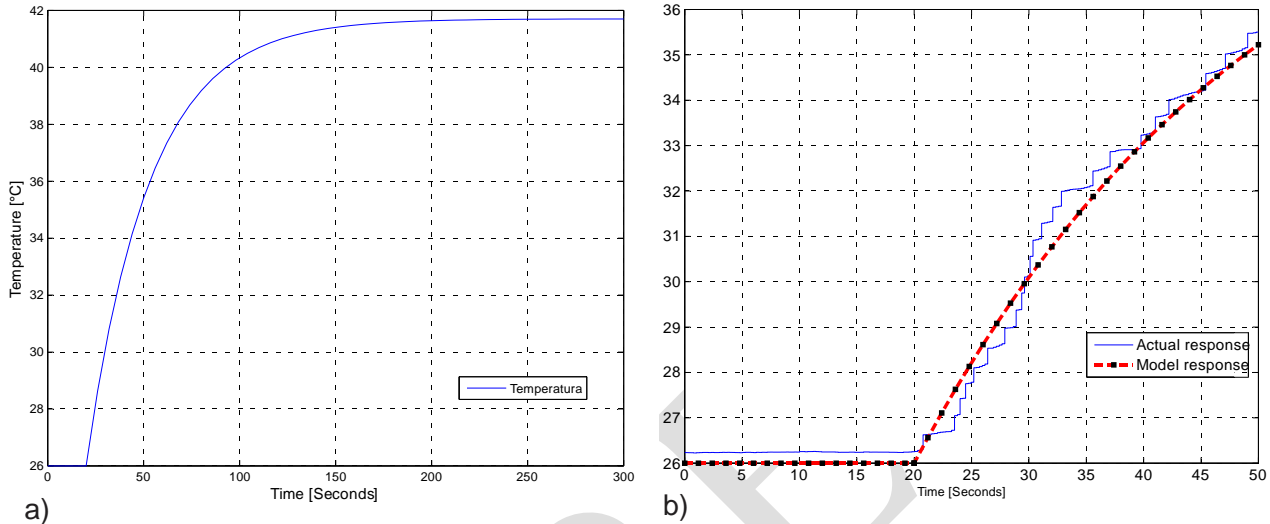

Figure 4 a). Dynamic response of the mathematical model simulated in Matlab. b). Both simulated and actual responses of the heating system. Source: authors.

D. PID temperature control design.

The control proposed for development is a PID feedback control. Figure 5 shows the conventional closed loop of a PID controller implemented with communication via the OPC protocol to read and write values directly on the process control system. In this control loop, the natural plant is used directly to extract the dynamic response, and on this same architecture, the tuning and adjustment result of the PID controller is validated using genetic algorithms. The goal is to develop a fine-tuning technique for PID control. The parameters of interest to optimize in this controller are the proportional constant K_p , the integral gain K_i , and the derivative gain K_d .

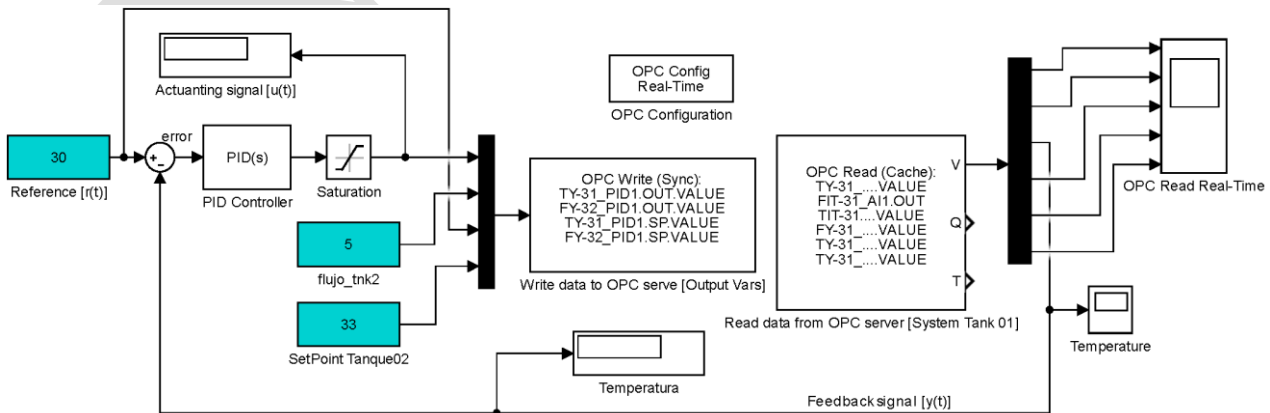

Figure 5. Closed-loop control system diagram with OPC connection. Source: authors.

A second closed-loop control using the mathematical model of the plant within the simulation environment is created for tuning tasks. The process of raising the temperature of the liquid to a reference point requires time and energy consumption, which makes it challenging to carry out repeated interactions on the natural process. The deduced model has the purpose of supporting the multiple interactions of the genetic algorithm in search of optimal parameters for the PID controller; when the stop criterion of the search algorithm determines that it found good values for the desired transient response, these parameters are tested in the control architecture presented in Figure 5.

E. Automatic tuning of the PID controller using genetic algorithms

A method based on genetic algorithms was developed for tuning the PID controller. The genetic algorithm is a stochastic search method that works on a population of solutions. Its behavior is inspired by an evolutionary process where the genetic content of a population contains essential information to achieve a better solution. A solution may not be evident because the appropriate combination of several individuals still does not occur. We can arrive at an optimal solution with the genetic association of different genomes. The objective of applying this method is to achieve fine-tuning for the PID control of the smart plant.

The first step is to create a relationship between the objective function and the optimal response of the plant associated with the variables K_p , K_i , and K_d . In the literature, it is widespread to find the construction of the objective function with the rules of the Ziegler-Nichols tuning method. This method differs by introducing specific design criteria into the desired transient response. The objective function evaluates the performance parameters on the system's response and compares with the design specification, seeking to minimize the difference between the current response and the desired response. The parameters that measure the performance of the controller and that are present in the transient response are:

- t_s : Settling time.
- t_r : Rise time.
- t_p : Peak time.
- t_d : Delay time.
- M_p : Peak overshoot.

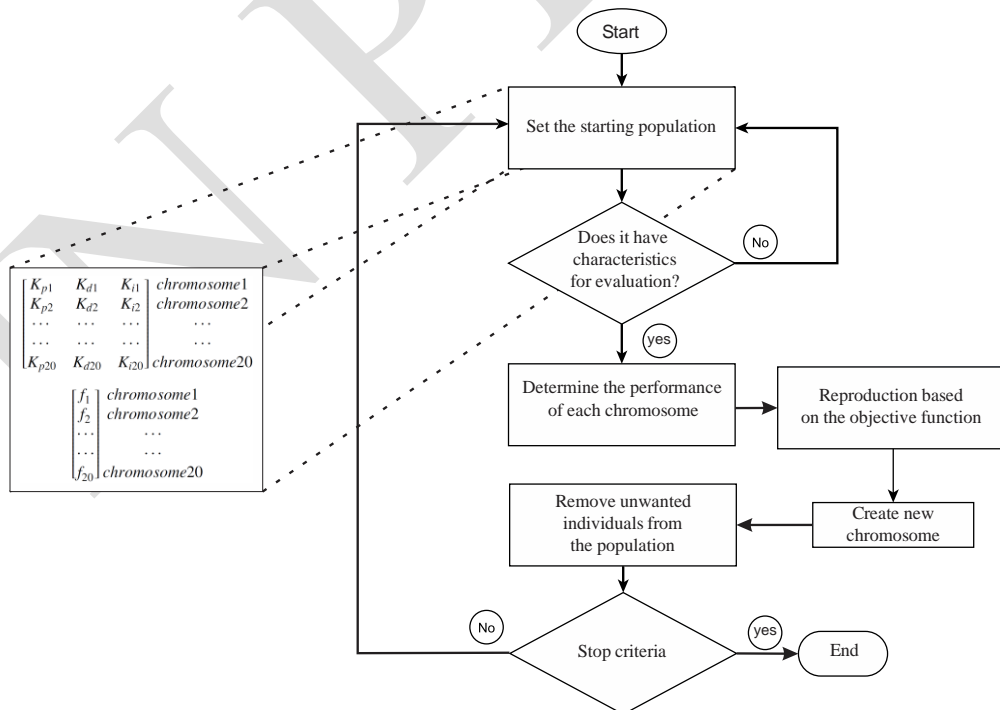

Figure 6 Flowchart of the Developed Algorithm for automatic tuning of the controller PID. Source: authors.

The population in each generation enters the optimization algorithm in the form of a matrix of 20 X 3 distinct values. Each row of the matrix is a chromosome representing K_p , K_i , and K_d ; the Figure 6 shows a schematic of the matrix structure. Each chromosome creates a control loop interaction with the natural system's mathematical model. In the simulation, the transient response obtained with each chromosome is evaluated by the objective function giving a performance value on the expected results. These obtained values define the minimization process in the algorithm, causing the search for values for K_p , K_i , and K_d that best performance in transient response present.

The objective function is defined based on the capture of the performance parameters of the PID control, measured in the transient response obtained in each interaction. From the transient response, the parameters *Settling time* (t_s), *Rise time* (t_r), *Peak time* (t_p), *Delay time* (t_d) and *Peak overshoot* (M_p) are extracted, and the yield of each chromosome is calculated using (13).

$$f = \omega_{peak} \cdot (M_p + P_{peak}) + \omega_{T_{ss}}(t_s) + \omega_{T_r}(t_r) + \omega_{T_p}(t_p) + \omega_{err}(SetPoint - V_{Estb}) \quad (13)$$

Where,

ω_{peak} : Weight to prioritize the variable *Peak overshoot*.

$\omega_{T_{ss}}$: Weight to prioritize the variable *Settling time*.

ω_{T_r} : Weight to prioritize the variable *Rise time*.

ω_{T_p} : Weight to prioritize the variable *Peak time*.

ω_{err} : Weight to prioritize the variable *error*.

With the mathematical model implemented in S-Function and connected in a closed loop with a PID controller, the transient response is obtained to extract the parameters that influence the performance of the control. With the objective function, the performance of each chromosome is calculated, and the corresponding mutations are carried out to include new individuals in the population that demonstrate the performance of control to the desired parameters. The cycle's stop criteria are when there is a significant variation in the scores awarded to the performance of each chromosome or when the time limit is exceeded without finding a solution.

III. RESULTS AND ANALYSIS

Two case studies are tested in the tuning process. Two different temperature values are set to test the method's effectiveness for different reference values. Figure 7 and Figure 8 show the transient responses generated for each chromosome in the optimization algorithm and the optimal solution for the design criterion established in a value of Thirty-five and forty-two degrees of reference temperature. The algorithm converges on generation fifty-one. Table 1 shows the values obtained for an optimal response according to the predefined design requirements.

Table 1. Parameters obtained for the PID controller of the heating tank.

Reference	K_p	K_d	K_i	f
35°C	1.3293	0.1098	0.9974	6.4489e+03
42°C	1.5789	0.9542	0.8879	5.8765 e+03

Source: authors

Figure 7 shows the response of the heating system with PID control, whose parameters are the values shown in Table 1. The response presents an allowable overshoot specified in the design criteria through the weights of the objective function. The final control instrument is a valve that regulates the flow of incoming cold water. The response of the final control element is greater than the change in temperature within the tank so that the process may experience some form of overdrive. The weights and reference temperature are changed to obtain a response without thrust while the response speed remains. The values obtained to obtain an answer according to the new design requirements are shown in Table 1.

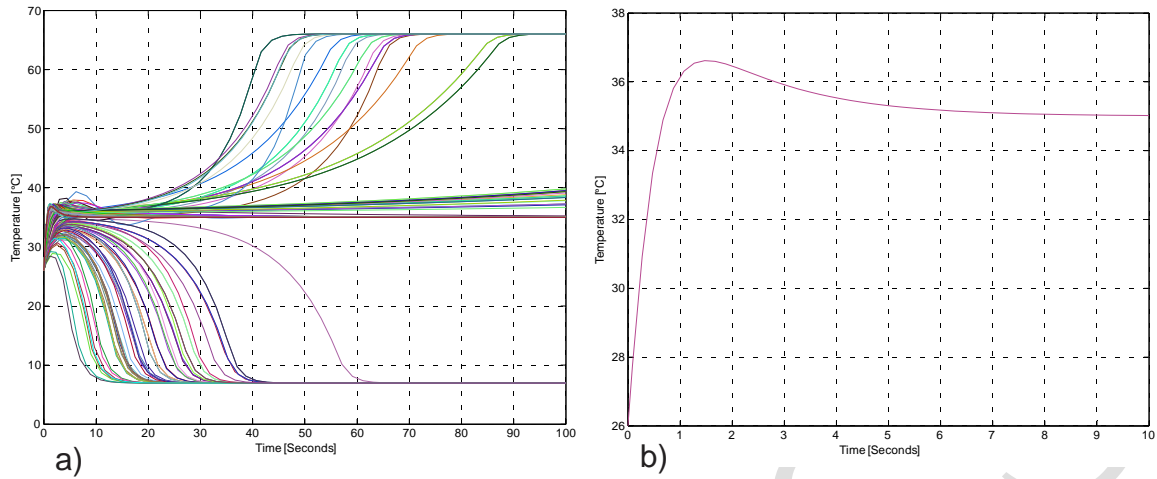

Figure 7. a). Transient responses are generated for each chromosome in the optimization algorithm. b) Optimal solution for the design criterion established in a value of Thirty-five degrees of reference temperature. Source: authors.

Figure 8 shows the response of the heating system for the PID control, which has the values shown in table 1 as parameters. The response has a high stabilization time but is acceptable in the specifications. The final control instrument is an electrical resistor that regulates the current flow. The response of the final control element is too slow to achieve a change in temperature inside the heating tank, so the process has a long stabilization time. The system response meets the specifications defined for the PID control. The parameters of the temporal response for the heating tank in front of a step input of forty y degrees of centigrade are presented in Table 1. The parameter values were extracted from the graph obtained from the process presented in Figure 8. Figure 9 shows the system response to reference variations and PID control response to reference variations.

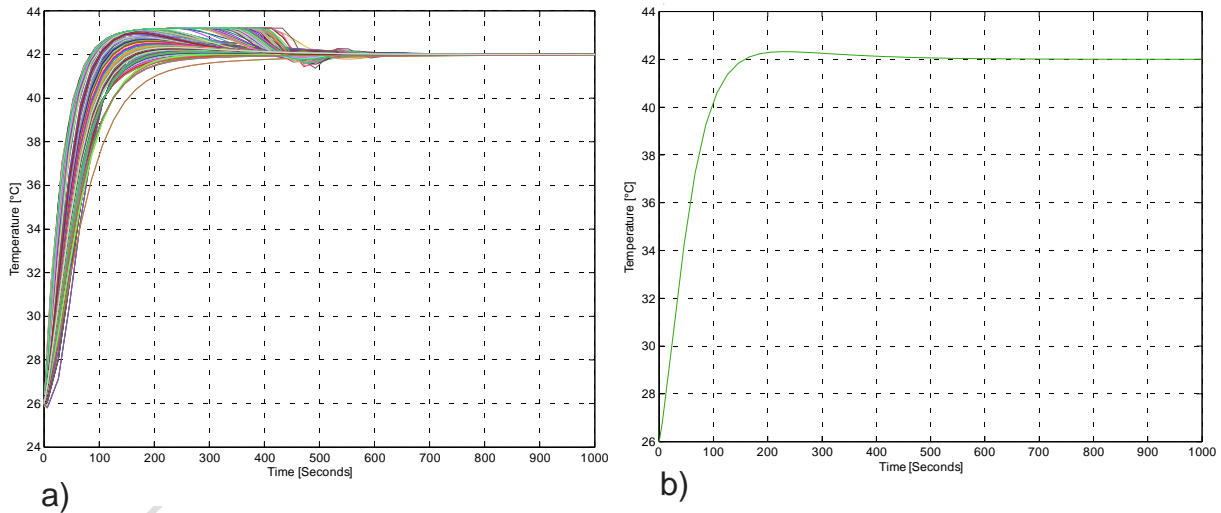

Figure 8. a). Transient responses are generated for each chromosome in the optimization algorithm. b) Optimal solution for the design criterion established in a value of forty-two degrees of reference temperature. Source: authors.

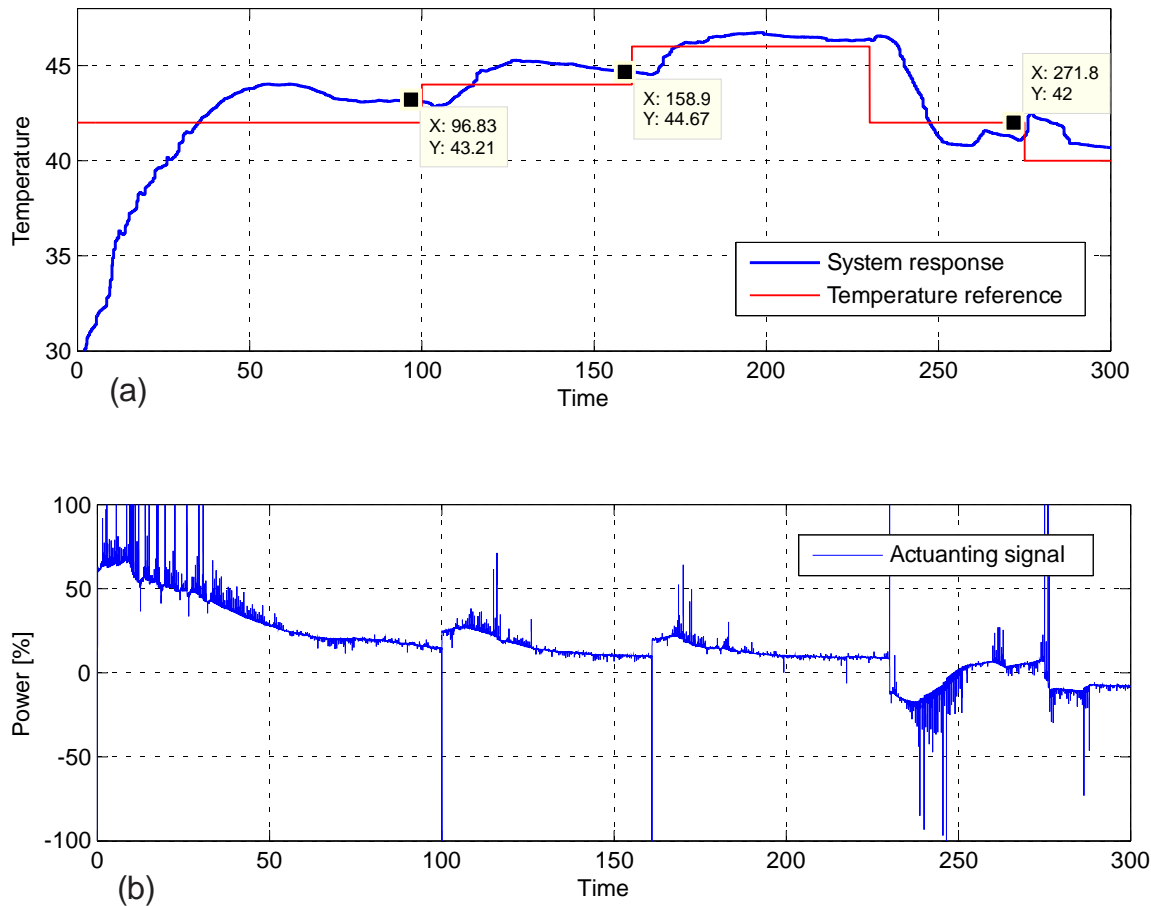

Figure 9. a) System response to reference variations b) PID control response to reference variations. Source: authors.

The control response manages to maintain the process temperature and effectively overcome the disturbances caused by the variable dynamics of the system. The adjustment method for this process was effective. The dynamics of the process presents different variations that are attributed to disturbances. The behavior of the natural process is different from the modeled and simulated linear system; however, it is a reasonably close approximation that preserves its naturalness. The most significant disturbances found in the process are because the flow of the heating tank does not have a constant temperature, the mixing process is not carried out effectively due to the lack of a mechanism to move the liquid inside, and the liquid leaves the process without stabilizing the temperature. The cold-water inlet used to lower the hot water temperature has a variable temperature and can take values higher than the reference temperature. Figure 9 shows the process response interacting with all disturbances. The objective of tuning the PID controller for the mixing tank was achieved, but the control actions, such as the output response, show that the tuning method manages to do its best job against disturbances. The most adverse considerations that occur when the processes have high temperatures as a reference are exposed in this work. shows the Smar Didactic Pilot Plant used to develop the automatic tuning method.

The most important result obtained in this research is the consolidation of a PID controller tuning methodology adaptable to different processes. The tuning methodology uses genetic algorithms that search for an optimal solution that meets the design criteria that can be adapted according to the need for control. The results showed that the process could be monitored, controlled, and automatically adjusted when required when the error goes out of the acceptable ranges, either due to changes in the reference, manual adjustments made to the process, or disturbances that affect performance. Process digitization and digital twin concepts for process control can be implemented through mathematical models adjusted to reality and sensors transmitting data in real-time. The presented strategy makes control feasible within this perspective and digital trend.



Figure 10. Smar Didactic Pilot Plant was used to develop the automatic tuning method. Source: authors.

IV. CONCLUSIONS

The control seeks to follow the step type input, due to the resistance's functional characteristics against high input flow, the response to temperature change needs time to stabilize at the new reference value. The response of the PID control is optimal for the system and manages to deal with the disturbances caused by being a process with a marked non-linear nature of the thermal process and the mixing process. The high variability of the process requires fine-tuning to operate over a more extensive range of temperatures. For the process to be more efficient, changes in the operation of the plant must be applied. The hot liquid outlet does not have to recirculate back into the process because it makes it challenging to control reference values for temperatures close to room temperature. A constant flow must be guaranteed without temperature gradients far above ambient temperature. The control action can quickly attend setpoints far from the ambient temperature.

The tuning method proposed in this article achieves an effective online tuning technique because it takes the natural dynamics and its transient response directly from the process. The response is used to measure the controller's performance against the design criteria based on the expected response. The search for optimal values for the PID controller parameters is performed randomly and does not require advanced control knowledge to define the search and tuning parameters, allowing its straightforward implementation in other processes of a different nature. The results obtained in system behavior show that the PID control action effectively maintains its validity and that, supported by new strategies such as the one presented in this article, it is possible to take advantage of its benefits in a better way. It opens the possibility of generalizing the exposed method for tuning PID controllers online using genetic algorithms; new case studies with processes of a different nature will be tested in this new approach resulting from this research.

ACKNOWLEDGMENTS

Special thanks to the University of Brasilia, the research group *Grupo de Inovação em Automação Industrial* (GIAI) and the Brazilian organization *Coordenação de aperfeiçoamento de pessoal superior* (CAPES).

REFERENCES

- [1] R. P. Borase, D. K. Maghade, S. Y. Sondkar y S. N. Pawar, «A review of PID control, tuning methods and applications,» *International Journal of Dynamics and Control*, vol. 9, p. 818–827, 2021.
- [2] V. Dubey, H. Goud y P. C. Sharma, «Role of PID Control Techniques in Process Control System: A Review,»

Data Engineering for Smart Systems, p. 659–670, 2022.

- [3] S. Albatran, I. A. Smadi y H. A. Bataineh, «Generalized optimal and explicit PI/PID tuning formulas for underdamped second-order systems,» *International Journal of Control, Automation and Systems*, vol. 18, p. 1023–1032, 2020.
- [4] A. Bagis, «Determination of the PID controller parameters by modified genetic algorithm for improved performance,» *Journal of Information science and Engineering*, vol. 23, p. 1469–1480, 2007.
- [5] Y. Chen, Y.-j. Ma y W.-x. Yun, «Application of improved genetic algorithm in PID controller parameters optimization,» *TELKOMNIKA Indonesian Journal of Electrical Engineering*, vol. 11, p. 1524–1530, 2013.
- [6] C. Huang y Y. Bai, «PID Tuning of Networked Feedforward-Feedback Control Systems,» de *Measuring Technology and Mechatronics Automation in Electrical Engineering*, Springer, 2012, p. 369–376.
- [7] S. Saxena y Y. V. Hote, «Internal model control based PID tuning using first-order filter,» *International Journal of Control, Automation and Systems*, vol. 15, p. 149–159, 2017.
- [8] Y. Mitsukura, T. Yamamoto y M. Kaneda, «A design of self-tuning PID controllers using a genetic algorithm,» de *Proceedings of the 1999 American Control Conference (Cat. No. 99CH36251)*, 1999.
- [9] K. Amuthambigaiyin Sundari y P. Maruthupandi, «Optimal Design of PID Controller for the analysis of Two TANK System Using Metaheuristic Optimization Algorithm,» *Journal of Electrical Engineering & Technology*, vol. 17, p. 627–640, 2022.
- [10] E. Jove, H. Alaiiz-Moretón, I. García-Rodríguez, C. Benavides-Cuellar, J. L. Casteleiro-Roca y J. L. Calvo-Rolle, «PID-ITS: an intelligent tutoring system for PID tuning learning process,» de *International Joint Conference SOCO'17-CISIS'17-ICEUTE'17 León, Spain, September 6–8, 2017, Proceeding*, 2017.
- [11] Z. Bingul, «A new PID tuning technique using differential evolution for unstable and integrating processes with time delay,» de *International Conference on Neural Information Processing*, 2004.
- [12] M. Gani, M. Islam, M. A. Ullah y others, «Optimal PID tuning for controlling the temperature of electric furnace by genetic algorithm,» *SN Applied Sciences*, vol. 1, p. 1–8, 2019.
- [13] M. Mavrinac, Z. Car, M. Šerčer y others, «Genetic Algorithm-Based Parametrization of a PI Controller for DC Motor Control,» *Tehnički glasnik*, vol. 16, p. 16–22, 2022.
- [14] S. P. Kodali, R. K. Mandava y B. N. Rao, «Development of an Optimal PID Controller for the 4-DOF Manipulator Using Genetic Algorithm,» de *Recent Advances in Industrial Production*, Springer, 2022, p. 23–32.
- [15] D. Shan, C. Li, X. Qiu y W. Wei, «PID Parameters Tuning Based on Self-Adaptive Hybrid Particle Swarm Optimization Algorithm,» de *Proceedings of the International Conference on Information Engineering and Applications (IEA) 2012*, 2013.
- [16] S. K. Singh y N. Katal, «Optimal tuning of PID controller for coupled tank liquid level control system using particle swarm optimization,» de *Proceedings of Sixth International Conference on Soft Computing for Problem Solving*, 2017.
- [17] C. Sravan Bharadwaj, T. Sudhakar Babu y N. Rajasekar, «Tuning PID controller for inverted pendulum using genetic algorithm,» de *Advances in Systems, Control and Automation*, Springer, 2018, p. 395–404.
- [18] N. Thomas y D. P. Poongodi, «Position control of DC motor using genetic algorithm based PID controller,» de *Proceedings of the world congress on engineering*, 2009.
- [19] J. C. Tudon-Martinez, J. d.-J. Lozoya-Santos, A. Cantu-Perez y A. Cardenas-Romero, «Advanced Temperature Control Applied on An Industrial Box Furnace,» *Journal of Thermal Science and Engineering Applications*, vol. 14, 2022.