

# Review of Suspension Control and Simulation of Passive, Semi-Active and Active Suspension Systems Using Quarter Vehicle Model

Jacob Kwaku Nkrumah<sup>a\*</sup>, Kwabla Sherry Amedorme<sup>b</sup>, Baba Ziblim<sup>c</sup>, David Inusah Offei<sup>d</sup>

<sup>a</sup>*Automotive Research Institute, Jiangsu University, No.301 Xuefu, Road, Zhenjiang, 21203, Jiangsu, China*

<sup>b</sup>*Department of Mechanical and Automotive Engineering, Akenten Appiah-Menka University of Skills Training and Entrepreneurial Development, Kumasi*

<sup>c,d</sup>*Tamale Technical University, Department of Automotive Engineering, Post Office Box 3 E/R, Tamale Ghana*

<sup>a</sup>*Email: jnkrumah@tatu.edu.gh, <sup>b</sup>Email: smedorme@yahoo.com*

<sup>c</sup>*Email: babaziblim7@gmail.com, <sup>d</sup>Email: offeidavidinusah@gmail.com*

## Abstract

This paper reviewed vehicle suspension control and also simulated passive, semi-active and active suspension system using quarter vehicle model with the help of Matlab software. The suspension system of a vehicle is meant to isolate the occupants of the vehicle from the disturbances occasioned by irregular road surface to improve ride quality. The main essence of this work is to review and assess the effectiveness of the vehicle suspension system by comparing the ride quality of passive, semi active and active suspension systems based on the set parameters. These parameters are: the unsprung mass displacement, sprung mass displacement and the suspension deflection. When the unsprung mass displacement and the sprung mass displacement were compared, it was found that, the passive suspension system has the highest magnitudes of both unsprung mass and sprung mass displacements. The active suspension system has the least unsprung mass and sprung mass displacements magnitudes. Based on these two parameters that were compared, it was therefore convenient to conclude that the active suspension system provides the best ride quality than the passive and semi-active suspension systems. The semi-active suspension system was also found to provide better ride quality than the passive suspension system based on unsprung mass and sprung mass displacements. When the suspension deflections of the passive, semi-active and active suspension systems were compared, it was found that, the semi-active suspension system has the least suspension deflection than the passive and active suspension systems under the same road conditions.

**Keywords:** Passive; Semi-Active; Active; Suspension Control; Sprung Mass; Unsprung Mass.

---

\* Corresponding author.

## **1. Introduction**

There are three (3) areas of study under vehicle dynamics. These areas are: longitudinal dynamics, lateral dynamics and vertical dynamics. The study of vibration of the vehicle body as results of the suspension spring and vehicle tyres due to irregular road surface or road profile comes directly under vertical dynamics [6]. Vehicle suspension system is one of the most important systems in the vehicle. The main essence of incorporating suspension system into the vehicle is to isolate the vehicle body and its occupants from the vibrational forces and its effects as a result of irregular road surface. There are many designs of suspension systems which are namely: Double wishbone suspension system, McPherson suspension system and Multi-link suspension system. These are the commonly used suspension systems in the vehicle application. Vehicle suspension systems are categorised into three different types namely: passive, semi-active and fully active suspension systems [7]. These systems are all geared towards improving the ride quality and dynamic control of the vehicle. The most important parameters that the designers of vehicles mostly consider are the safety, control dynamics and comfort of the ride or ride quality. The biggest enemy of the moving vehicle in terms of safety and ride comfort is vibration. The vibrations expose to vehicle body can emanate from the vehicle engine, shafts, gearbox, wind and irregular road conditions. The exposure to vibrations, has direct effect on the driver's health, vehicle stability and also, it has negative effect on the occupants of the vehicle. More also, these vibration cause wear and tear of the vehicle's components leading to frequent maintenance of the vehicle. The system used to suppress these negative effects of vibration in vehicles is the suspension system. Due to these reasons, suspension systems stand out as one of the most important parts of vehicle dynamics. The suspension system, in its most general form, consists of a spring and damper, providing the connection between the wheel and the shaft and therefore has a direct effect on the driving dynamics [4]. In the past vehicle suspension system was a purely mechanical system. The whole system was simple and the ride quality offered was very poor. Improvement of the suspension system by various researches have been done both for automotive and railway vehicle sectors [2]. What this study intends to do is to compare the ride comfort of these three suspension systems based on certain parameters by using quarter vehicle model technique.

## **2. Literature review**

The two fundamental criteria of good vehicle suspension system performance are typically their ability to provide a good road handling and increased ride comfort. The main disturbance affecting these two criteria is road surface irregularities. Active suspension control systems reduce these undesirable effects by isolating vehicle body motion from vibrations at the road wheels. Vehicle suspension system performance is basically rated by its ability to provide improved road handling and improved occupant comfort. Current automobile suspension systems using passive components can only offer a compromise between these two conflicting criteria by providing spring and damping coefficients with fixed rates. The traditional engineering practice of designing spring and damping, function as two separate entities which has been a compromise from its inception in the late 1800s [8]. Poor road handling capability and decreased occupant comfort are due to excess vehicle body or sprung mass vibrations resulting in artificial vehicle speed limitations, reduced vehicle chassis life, un-comfortability of occupant, and detrimental consequences to freight. Active suspension control systems aim to reduce these undesirable effects by isolating the vehicle body from road wheel vibrations induced by irregular

road surface. The main objective of suspension systems is to reduce motions of the sprung mass or vehicle body. Many control approaches have been investigated for the full vehicle model, half vehicle model and quarter vehicle model using suspension control methods such as nonlinear control, optimal control and back stepping control [6]. Additionally, optimal control approaches have been applied to the full vehicle model as well. An active suspension system should be able to provide different behavioural characteristics dependent upon various road conditions and be able to do so without going beyond its travel limits [1]. It is a known fact that using a force control loop to compensate for the hydraulic dynamics can destabilize the system. This full nonlinear control problem of active suspensions has been investigated using several approaches including optimal control. Moreover, several assumptions of linearity in the parameters are needed, which may not be satisfied by actual systems [8]. The use of fuzzy logic (FL) systems has accelerated in recent years in many areas, including feedback control. A fuzzy logic approach for the active suspension control of a hydro-pneumatic actuator is a possible way of suspension control [9]. Particularly important in FL control are the universal function approximation capabilities of FL systems. Given these recent results, some rigorous design techniques for FL feedback control based on adaptive control approaches have now been given. FL systems offer significant advantages over adaptive control, including no requirement for linearity in the parameters assumptions and no need to compute a regression matrix for each specific system. Since the initiation of the fuzzy set theory, Fuzzy Logic Control (FLC) schemes have been widely developed and successfully applied to many real-world applications including the vehicle suspension. Besides, FLC schemes have been used to control suspension systems [9]. [8] Opined and concluded in their study that, a fuzzy control for active suspension system to improve the ride comfort. Other researchers have used a robust controller for a full vehicle linear active suspension system using the mixed parameter synthesis and found its performance to be incredible. Due to the fact that strong nonlinearity inherently exists in the damper and spring components, inevitably the nonlinear effect must be taken into account in designing the controller for practical active suspension systems. Account for the three motions of the vehicle body: vertical movement at centre of gravity, pitching movement and rolling movement. An intelligent controller can be used to design a control system for a full vehicle nonlinear active suspension system such as Neural Controller (NC) [5]. Neural Networks (NNs) are capable of handling complex and nonlinear problems, process information rapidly and can reduce the engineering effort required in controller model development. Improvement in suspension systems plays an important role in achieving the goals of pursuing more comfortable and safer vehicles. Naturally, the suspension systems are then expected to have more intelligence to accommodate themselves in various road conditions. Hence, many control methods such as classical control, optimal control, nonlinear control, robust control adaptive control and intelligent control have been used for vehicle suspension controller design. However, model uncertainties due to the parameter uncertainties and unknown road inputs in real suspension systems bring a great challenge for the controller design [11]. It is well known that optimal controllers are normally designed offline by solving Hamilton-Jacobi-Bellman (HJB) equation. For linear system, linear quadratic regulator (LQR) controller is designed offline by solving the rickety equation (special case of HJB). However, the main drawback of the conventional LQR method lies in the fact that the system model has to be known precisely in advance to find the optimal control law. In addition, the feedback control gains are obtained offline [11]. Once the feedback gains of the controllers are obtained, they cannot be changed with the different driving environment. Thus, a more efficient control strategy is needed to adaptively cope with an active suspension control problem subject to time varying

parameters under different driving situations in real time. Most of the available adaptive optimal control methods are usually based on the dual NN architecture, where the critic NN and action NN are employed to approximate the optimal cost function and optimal control policy, respectively. The complicated structure and computational burden make the practical implementation difficult.

### Passive Suspension System

This type of suspension system is commonly used to control the dynamics of a vehicle's vertical motion as well as spinning (pitch) and tilting (roll). Passive indicates that the suspension elements cannot provide energy to the suspension system. The passive suspension system limits the motion of the vehicle body and wheel by limiting their relative velocities to a rate that gives the required ride comfort. This is achieved by using some type of damping element placed between the body and the wheels of the vehicle, such as hydraulic shock absorber [3]. Properties of the dampers are desired to reduce the vertical vehicle body acceleration and to provide good tyre-road contact force. That is, for a comfortable ride, it is desirable to limit the vehicle body acceleration by using a soft absorber, but this allows more variation in the tyre-road contact force that in turn reduces the handling performance of the vehicle. Also, the suspension travel, commonly called the sprung mass (the mass of vehicle body and other components supported by suspension system) displacement, limits allowable suspension deflection, which in turn limits the amount of relative velocity of the shock absorber that can be permitted [7]. By comparison, it is desirable to reduce the relative velocity to improve handling by designing a stiffer or higher rate shock absorber. This stiffness decreases the ride quality performance at the same time increases the vehicle body acceleration, detract what is considered being good ride characteristics [8]. An early design for automobile suspension systems focused on unconstrained fulfilment of results for passive suspension system which shows the desirability of low suspension stiffness, reduced unsprung mass, and better damping ratio for the best controllability. Thus, the passive suspension systems, which approach optimal values, had offered an appealing choice for a vehicle suspension system and had been widely used on vehicles. However, the conventional shock absorbers do not provide energy to the suspension system and control only the displacement of the vehicle body and wheel by limiting the sprung mass and unsprung mass velocity according to the rate determined by the designers. Hence, the optimization of a passive suspension system is varied according to the road profiles. Passive suspension system representation diagram of a quarter vehicle model is as shown in Fig.1.

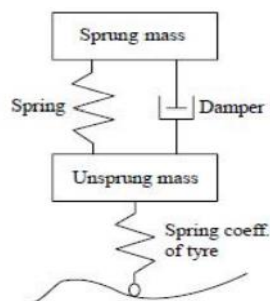

**Figure 1:** Quarter Vehicle Model Showing Passive Suspension System [7].

## Semi-Active Suspension Systems

In passive suspension systems, changing the selected suspension system parameters during vehicle design is the reason for the emergence of semi-active suspension systems [11]. In such systems, passive spring is replaced by models with which the damping coefficient can be adjusted externally while maintaining the element position. However, when passive suspension systems do not have an action such as parameter change, an extra energy source is not needed for this process, while semi-active suspension systems require an external energy source to adjust the damping coefficient and to operate the controller systems and sensors [4]. In the semi-active suspension system, the required damping force is calculated by the controller using the data collected from the vehicle through the sensors and the damping coefficient is adjusted by sending the necessary commands to the damper [9]. The important thing at this point is that the damping force depends on both the damping coefficient and the relative speed of the damper [4].

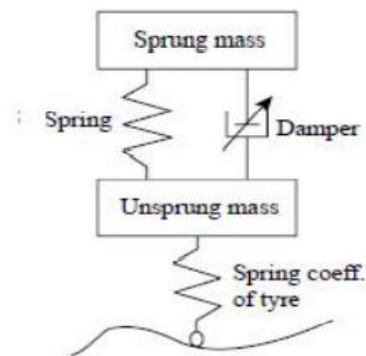

**Figure 2:** Quarter Vehicle model Showing Semi-Active Suspension System [4]

## Active Suspensions

Compared to other previous systems, an active suspension includes an actuator that can supply active force regulated by a controlling algorithm which uses information gathered from attached vehicle sensors. As illustrated in Fig. 3, active suspension system comprises an actuator, mechanical spring, and damper; or an actuator and mechanical spring only. These kinds of systems have much better reacting capabilities against generated vertical forces caused by unpredictable road input changes since the dampers as well as springs are regulated through an actuator force. This actuator operates by allowing or spreading energy from the system and could moderate through different controller types based on intended design. With proper controlling methods, an active suspension can result in compromise between vehicle ride comforts to road handling stableness be more improved, thus making it an overall enhanced suspension design [1].

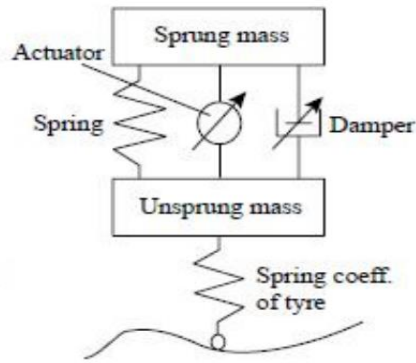

**Figure 3:** Quarter Vehicle model showing Active Suspension System [1]

### 3. Methods

Ride performance is assessed at the design stage by simulation of the vehicle's response to road innervation. This requires the development of a vehicle model and analysis of its response. Model of varying complexity are used. For a passenger car, the most comprehensive of these models has seven degrees of freedom (DoFs) as shown in Figure 4. These comprise three degrees of freedom for the vehicle's body which are moments by names: Pitch moment, yaw (bounce) moment and rolling moment. There are further vertical degrees of freedom at each of the four unsprung masses. These models allow the pitch, yaw and roll performance of the vehicle to be studied. The suspension stiffness and damping rates in the model are derived from the individual spring and damping units using the kinematics approach. The simplest of these models uses a point-contact model to represent the elasticity and damping in the tyre with a simple spring and viscous damper. Since tyre damping is in several orders of magnitude lower than suspension damping, it can be neglected in basic vehicle models.

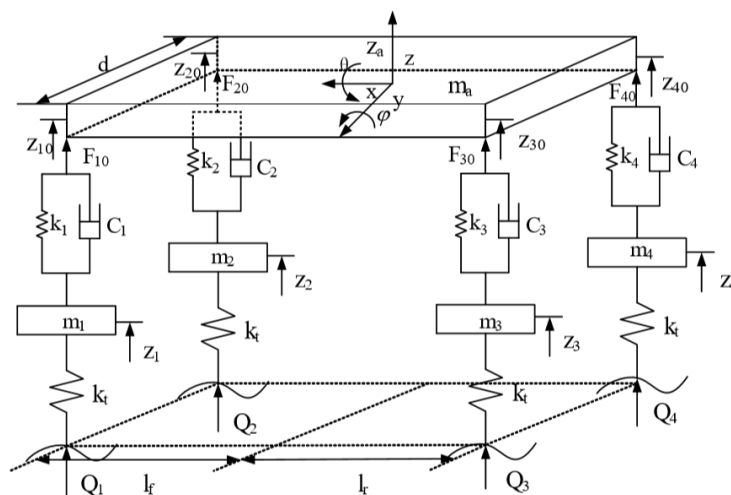

**Figure 4:** Full Vehicle Model for Vehicle Suspension System

Much useful information can be derived from simpler vehicle models than the full vehicle model shown in Figure 4. For a normal road surface profile, the components having the longer wavelength components are in coherent across the left and right tracks of a vehicle and there is therefore no tendency to excite body roll. This then justifies the use of a half vehicle model as shown in Figure 5. This has four degrees of freedom which are: a body mass translation and rotation, plus a translation for each of the unsprung axle masses [8].

The half vehicle model can be simplified still further to a quarter vehicle model as shown in Figure 6 if the body mass satisfies certain conditions. In the case of quarter vehicle model, the mass of the vehicle body and the occupants is represented as a single mass element called the sprung mass ( $M_s$ ). The unsprung mass ( $M_u$ ) consists of the mass of the wheel assembly. A spring and a damper are used to model the suspension system between the sprung and unsprung masses while another set of spring and damper are used to model the tyre stiffness and internal damping respectively. For the quarter vehicle model representation of Active Suspension System, only the actuating force is considered. The actuator is not modelled explicitly for simplicity, and hence the actuator dynamics are not considered making it an ideal actuator. As quarter vehicle model is most simple to implement, it comes with the inherent limitations. The roll and pitch motion of the vehicle cannot be modelled using quarter vehicle model. Also, the effect of dependent motion of individual wheel suspensions is not taken into consideration [9].

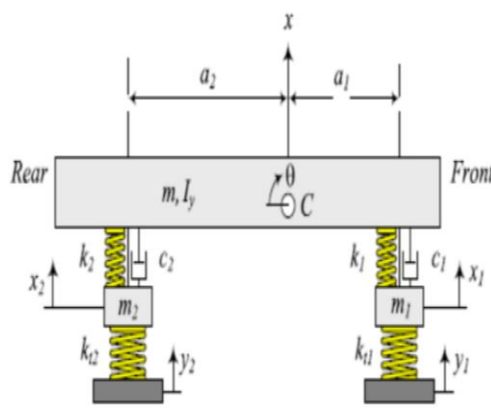

Figure 5: Half vehicle model [10]

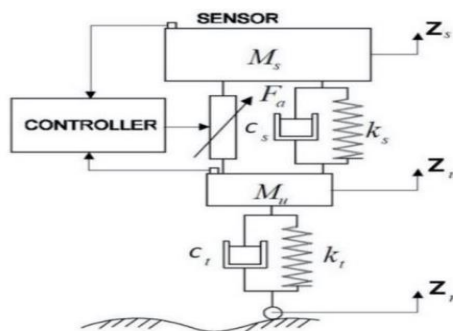

Figure 6: Quarter vehicle model [9].

### 3.1 Mathematical modelling of Quarter vehicle model

There are three different types of mathematical vehicle models for suspension system. These models are: full vehicle model as shown in Figure 4, half vehicle model as shown in Figure 5 and quarter vehicle model as shown in Figure 6. For the purpose of this work, quarter vehicle model will be considered for the analysis of the vehicle suspension spring. These mathematical models are normally used to analyse the displacement behaviour of a vehicle suspension when moving on an irregular or uneven road surface. These models come with their varied complexities; the quarter vehicle model is the simplest among all. The quarter vehicle suspension system consists of one-fourth of the vehicle body mass, suspension components and one wheel. Figure 6 shows the quarter vehicle model which was considered for the mathematical analysis. The assumptions that were used for the mathematical modelling include but not limited to: the tyre is modelled as a linear spring without damping force, there is no rotational motion in the wheel and body, the behaviour of spring and damper are linear, the tyre is always in contact with the road surface and its effects on friction is neglected so the residual structural damping is not considered in the vehicle modelling [7]. The equations of motion for the active, semi-active and passive quarter vehicle models have the following variables:  $Z_s$  and  $Z_u$  are the vertical displacements of the sprung and unsprung masses, respectively. The road profile is denoted by  $Z_r$ . The derivatives, that is, the velocities and accelerations of the sprung and unsprung masses, are represented by a single and double dot over the variables, respectively.  $K_s$  is the stiffness of the suspension spring and  $C_s$  is the damping coefficient of the suspension damper. The tyre stiffness is represented by  $K_t = K_u$  and internal damping coefficient of the tyre is  $C_t = C_u$ . The actuation force is given as  $F_a$ .

The quarter vehicle model for the Passive Suspension System can be obtained simply by removing the actuation force term from the equation of motions.

#### Variables Considered

$Z_s$  – Sprung mass displacement

$\dot{Z}_s$  – Sprung mass velocity

$Z_u$  – Unsprung mass displacement

$\dot{Z}_u$  – Unsprung mass velocity

$Z_r$  – Road profile

$\theta$  – Pitch Angle

$\dot{\theta}$  – Pitch angle velocity

$\phi$  – Roll Angle



$\dot{\phi}$  – Roll angle velocity

### 3.2 Mathematical modelling of Quarter vehicle passive suspension system

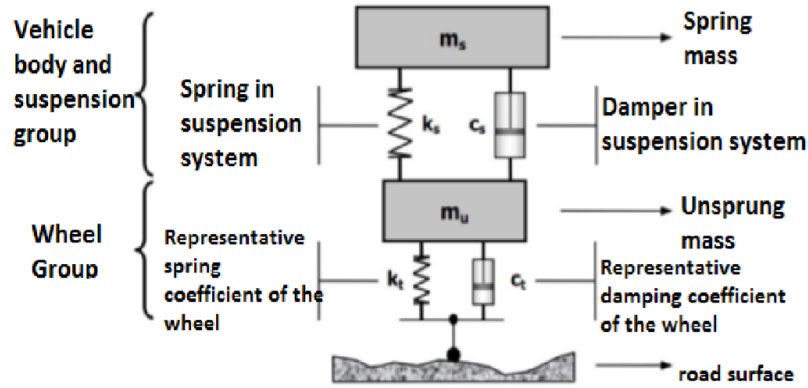

Figure 7: Quarter Vehicle model of Passive suspension system [4].

#### Equations of motion of passive suspension system for quarter vehicle model

$$M_s \ddot{Z}_s + C_s(\dot{Z}_s - \dot{Z}_u) + K_s(Z_s - Z_u) = 0 \quad (1)$$

$$M_u \ddot{Z}_u + C_s(\dot{Z}_u - \dot{Z}_s) + K_s(Z_u - Z_s) + K_u(Z_u - Z_r) = 0 \quad (2)$$

$$\ddot{Z}_s = \frac{1}{M_s} [C_s(\dot{Z}_u - \dot{Z}_s) + K_s(Z_u - Z_s)] \quad (3)$$

$$\ddot{Z}_u = \frac{1}{M_u} [C_s(\dot{Z}_s - \dot{Z}_u) + K_s(Z_s - Z_u) + K_u(Z_r - Z_u)] \quad (4)$$

Let the state variables be:

$$Z_1 = Z_s - Z_u \quad (5)$$

$$Z_2 = \dot{Z}_s \quad (6)$$

$$Z_3 = Z_u - Z_r \quad (7)$$

$$Z_4 = \dot{Z}_u \quad (8)$$

$$\dot{Z}_1 = \dot{Z}_s - \dot{Z}_u \approx \dot{Z}_s - \dot{Z}_u \quad (9)$$

$$\dot{Z}_2 = \ddot{Z}_s \quad (10)$$

$$\dot{Z}_3 = \dot{Z}_u - \dot{Z}_s \approx \dot{Z}_u - \dot{Z}_s \quad (11)$$

$$\dot{Z}_4 = \dot{Z}_u \tag{12}$$

General form of state space equation

$$\dot{Z} = AZ + BF_a + \dot{Z}_r \tag{13}$$

$$\begin{pmatrix} \dot{Z}_1 \\ \dot{Z}_2 \\ \dot{Z}_3 \\ \dot{Z}_4 \end{pmatrix} = \begin{pmatrix} 0 & 1 & 0 & -1 \\ -K_s/M_u & -C_s/M_u & 0 & C_s/M_u \\ 0 & 0 & 0 & 1 \\ -K_s/M_s & C_s/M_s & -K_u/M_s & -C_s/M_s \end{pmatrix} \begin{pmatrix} Z_1 \\ Z_2 \\ Z_3 \\ Z_4 \end{pmatrix} + \begin{pmatrix} 0 \\ 0 \\ -0 \\ 0 \end{pmatrix} \dot{Z}_r$$

### 3.3 Mathematical modelling of active and semi-active suspension system

The only difference between active, semi-active and passive suspension systems in mathematical modelling is the addition of the damper force to the equation of motion of the passive suspension system to get the equation of motion for the active and semi-active suspension systems. The equation of motion of the active and semi-active suspension system is as given below:

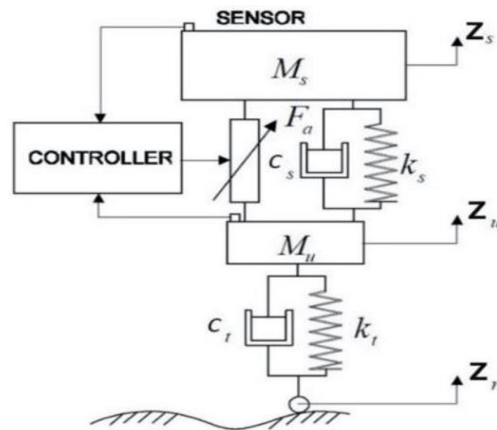

**Figure 8:** Quarter vehicle model of semi-active suspension system [3]

$$M_s \ddot{Z}_s + C_s(\dot{Z}_s - \dot{Z}_u) + K_s(Z_s - Z_u) + F_a = 0 \tag{15}$$

$$M_u \ddot{Z}_u + C_s(\dot{Z}_u - \dot{Z}_s) + K_s(Z_u - Z_s) + K_u(Z_u - Z_r) - F_a = 0 \tag{16}$$

$$\ddot{Z}_s = \frac{1}{M_s} [C_s(\dot{Z}_u - \dot{Z}_s) + K_s(Z_u - Z_s) - F_a] \tag{17}$$

$$\ddot{Z}_u = \frac{1}{M_u} [C_s(\dot{Z}_s - \dot{Z}_u) + K_s(Z_s - Z_u) + K_u(Z_r - Z_u) + F_a] \tag{18}$$

Let the state variables be:

$$Z_1 = Z_s - Z_u$$

$$Z_2 = \dot{Z}_s$$

$$Z_3 = Z_u - Z_r$$

$$Z_4 = \dot{Z}_u$$

$$\dot{Z}_1 = \dot{Z}_s - \dot{Z}_u \approx Z_s - Z_u$$

$$\dot{Z}_2 = \ddot{Z}_s$$

$$\dot{Z}_3 = \dot{Z}_u - \dot{Z}_s \approx Z_u - Z_r$$

$$\dot{Z}_4 = \ddot{Z}_u$$

General form of state space equation

$$\dot{Z} = AZ + BF_a + \dot{Z}_r$$

$$\begin{pmatrix} \dot{Z}_1 \\ \dot{Z}_2 \\ \dot{Z}_3 \\ \dot{Z}_4 \end{pmatrix} = \begin{pmatrix} 0 & 1 & 0 & -1 \\ -K_s/M_u & -C_s/M_u & 0 & C_s/M_u \\ 0 & 0 & 0 & 1 \\ -K_s/M_s & C_s/M_s & -K_u/M_s & -C_s/M_s \end{pmatrix} \begin{pmatrix} Z_1 \\ Z_2 \\ Z_3 \\ Z_4 \end{pmatrix} + \begin{pmatrix} 0 \\ \frac{1}{M_u} \\ 0 \\ \frac{1}{M_s} \end{pmatrix} F_a + \begin{pmatrix} 0 \\ 0 \\ -1 \\ 0 \end{pmatrix} \dot{Z}_r \tag{19}$$

In order to get bases to compare the displacements and the velocities of the passive suspension system, this work also considered Active and Semi-Active suspension systems of a quarter vehicle model. The equations of motion for the sprung and unsprung masses of the semi-active and active suspension quarter vehicle models are identical. In the case of semi-active suspension system, the variable of the damper will provide the needed force. On the other hand, the Active suspension system requires an actuating force to provide a comfortable ride and control than the passive suspension system. The actuator force ( $F_a$ ) is an additional input to the suspension

system model. These models can be built in Simulink using MatLab software as shown in Figure 9

### 3.4 Parameters for Simulation

The following parameters were used in the MatLab simulation. Body mass ( $M_s$ ) = 300 kg, Suspension mass ( $M_u$ ) = 80 kg, spring constant of Suspension system ( $K_s$ ) = 17200 N/m, spring constant of wheel and tire ( $K_u = K_t$ ) = 196000 N/m, damping constant of suspension system ( $C_s$ ) = 1200 Ns/m, control force ( $F_a$ ), the  $Z_s$ ,  $Z_u$  are the sprung mass and unsprung mass displacement. The  $\dot{Z}_s, \dot{Z}_u, \ddot{Z}_s, \ddot{Z}_u$  are the sprung mass and unsprung mass velocities and accelerations. The Figure 9 shows the passive suspension system simulation block diagram.

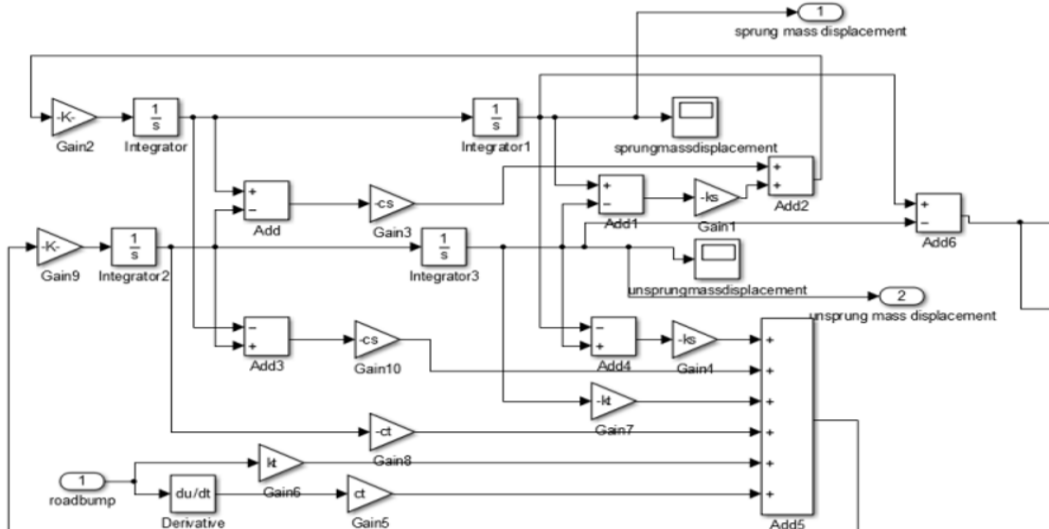

Figure 9: Simulink block for passive quarter vehicle model suspension system

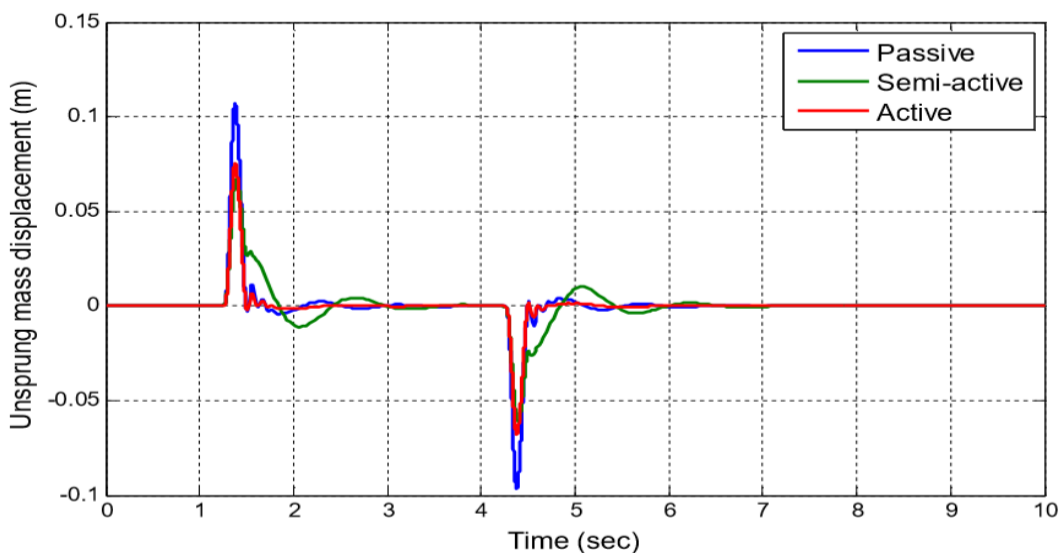
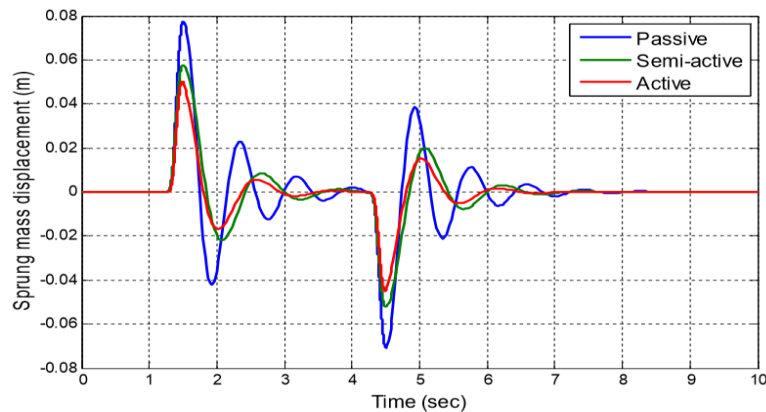

Figure 10: Unsprung Mass Displacement

#### 4. Simulated Results and Discussion

Figure 10 shows a graph of unsprung mass displacement against time. As indicated on the graph, the blue line indicates the unsprung mass displacement of the passive suspension system, the green line represents the unsprung mass displacement of the semi-active suspension system and the red line represents the unsprung mass displacement of the active suspension system. The unsprung mass displacement is the working space between the road surface and the unsprung mass or the working space of the vehicle tyre.

The simulation results as shown in Figure 10 indicates that, the unsprung mass positive displacement of the passive suspension system is much higher than the semi-active and active suspension systems. It was observed that, the positive displacement of the unsprung mass of both passive and semi-active occurred at the same time of about 1.3 seconds and fell at the same time at about 1.6 seconds but with varied magnitudes of unsprung mass positive displacement. The unsprung mass displacement magnitude of the passive suspension system is about 0.11m while the unsprung mass displacement magnitude of the semi-active suspension system towards the positive direction is about 0.075m under the same road conditions. The vibrational response characteristics of both passive and semi-active suspension systems have the same time delay response of about 4 seconds. The passive and semi-active suspension systems have almost the same characteristics with the only difference of variable unsprung mass displacement magnitudes. It was again observed that, the unsprung mass displacement characterisation of the active suspension system is of a sinusoidal quadratic of the form ( $x^3$ ) in nature. The active suspension system has the least unsprung mass displacement with uniform vibrational characteristics under the same road conditions as shown in Figure 10. The graph in Figure 10 actually shows the behaviour of a vehicle tyre on an irregular road surface.

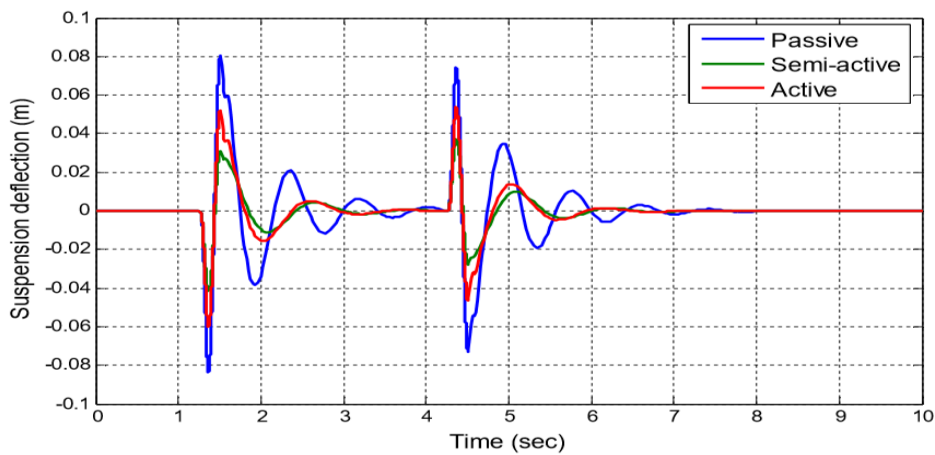

**Figure 11:** Sprung Mass Displacement

Again, Figure 11 shows a graph of sprung mass displacement against time. As indicated on the graph, the blue line indicates the sprung mass displacement of the passive suspension system, the green line represents the sprung mass displacement of the semi-active suspension system and the red line represents the sprung mass displacement of the active suspension system. The sprung mass displacement is the movement of vehicle body as a result of irregular road surface. The main aim of automotive designers is to reduce the sprung mass

displacement of the vehicle body in order to improve the ride quality.

The simulation results as shown in Figure 11 indicates that, the sprung mass displacement of the passive suspension system is much higher than the semi-active and active suspension systems. It was observed that, the sprung mass displacement of passive, semi-active and active suspension systems delayed for about 1.3 seconds before the start of vibration which lasted for about 7 seconds before dying off gradually. It was again observed that, the passive suspension system has the highest magnitude of 0.07 m of sprung mass displacement in the positive direction and 0.041m towards the negative direction, the semi-active suspension system has a sprung mass displacement of 0.055m towards the positive direction and 0.021m towards the negative direction and the active suspension system has the least magnitudes of sprung mass displacement of 0.044m towards the positive direction and 0.018m towards the negative direction under the same road condition. The vibrational response characteristics of passive, semi-active and active suspension systems are the same but with varied magnitudes of sprung mass displacements. It was again observed that, the sprung mass displacement characterisation of the passive, semi-active and active suspension system is of a sinusoidal quadratic of the form  $(x^3)$  graph in nature. The active suspension system has the least sprung mass displacement with uniform vibrational characteristics under the same road conditions as shown in Figure 11.



**Figure 12:** Suspension Deflection

Figure 12 shows a graph of suspension deflection against time. As indicated on the graph, the blue line indicates the suspension deflection of the passive suspension system, the green line represents the suspension deflection of the semi-active suspension system and the red line represents the suspension deflection of the active suspension system. The suspension deflection is the difference between sprung mass displacement ( $Z_s$ ) and the unsprung mass displacement ( $Z_u$ ). It can be represented mathematically as  $\delta = Z_s - Z_u$ , this space can also be referred to as the rattle space. The main aim of automotive designers is to reduce the suspension deflection or the rattle space as much as possible to improve the vehicle ride quality. The suspension deflection is an important parameter that is used to assess the effectiveness of the suspension system.

The simulation results as shown in Figure 12 indicate that, the deflection of the suspension of the passive suspension system is much higher than the semi-active and active suspension systems. It was observed that, the

deflection characteristics of the nature of the vibration is opposite to the vibrational characteristics of sprung mass displacement and the unsprung mass displacement graphs of passive, semi-active and active suspension systems under the same road condition. It was again observed that, the passive suspension system deflected more than the semi-active and active suspension systems. Again, there is a time delay of about 1.3 seconds before the start of the vibrational deflection which lasted for about 7 seconds before the deflection begins to smoothen out to normality. Here, the graph in Figure 12 shows that, the deflection displacement first moved towards the negative direction to start the vibration which is opposite of the unsprung mass displacement and sprung mass displacement graphs shown in Figure 10 and 12 respectively. It was further observed that, the passive suspension system has the highest magnitude of 0.08 m of suspension deflection in the positive direction and 0.081m towards the negative direction, the semi-active suspension system has a suspension deflection magnitude of 0.025m towards the positive direction and 0.04m towards the negative direction and the active suspension system has a suspension deflection magnitudes 0.045m towards the positive direction and 0.06m towards the negative direction under the same road condition. It was detected that, the semi-active suspension system has the least suspension deflection compared to passive and active suspension systems. The vibrational response characteristics of passive, semi-active and active suspension systems are the same but with varied magnitudes of suspension deflections. It was again noted that, the suspension deflection characterisation of the passive, semi-active and active suspension systems are of a sinusoidal quadratic of the form  $(x^3)$  graph in nature.

## 5. Conclusion

Suspensions control is highly a difficult control problem due to the complicated relationship between its components and parameters. Many researches were carried out by different authors in suspension control systems, this covers a broad range of design issues and challenges. The challenge here for researchers is to select the best control method to design a suspension system that will guarantee vehicle safety and ride comfort.

The main essence of this work is to assess the effectiveness of the vehicle suspension system by comparing the ride quality of passive, semi active and active suspension systems based on the set parameters. The report actually considered the quarter vehicle model with three parameters for assessment. These parameters are: the unsprung mass displacement, sprung mass displacement and the suspension deflection. A well-designed suspension system which is able to perform the functions set for the suspension systems is the one that is able to isolate the vibrational effects from the suspension system as a result of irregular road profile or surface from the sprung mass or the vehicle body to improve ride quality. The designers of the vehicle suspension systems main aim is to reduce the unsprung mass displacement, the sprung mass displacement and the rattle space or the suspension deflection to the barest minimum to increase the ride quality. When these parameters were simulated using matlab software, to generate the performance graphs of the unsprung mass displacement, sprung mass displacement and the suspension deflection as shown in Figures 10, 11 and 12 respectively. The report can therefore be concluded as follows:

When the unsprung mass displacement and the sprung mass displacement were compared, it was found that, the passive suspension system has the highest magnitudes of both unsprung mass and sprung mass displacements.

The active suspension system has the least unsprung mass and sprung mass displacements magnitudes. Based on these two parameters that were compared, it is therefore convenient to conclude that the active suspension system provides the best ride quality than the passive and semi-active suspension systems. The semi-active suspension system was also found to provide better ride quality than the passive suspension system based on unsprung mass and sprung mass displacements. The passive suspension system has the least ride quality based on the set parameters and under the same road condition. When the suspension deflections of the passive, semi-active and active suspension systems were compared, it was found that, the semi-active suspension system has the least suspension deflection than the passive and active suspension systems under the same road conditions. Hence, if the suspension deflection parameter alone were used to measure the effectiveness of the suspension systems, the semi-active suspension system would have provided the best ride quality. The active suspension system was found to deflect more than the semi-active but less than the passive suspension system. The parameters that were set to measure the effectiveness of the three suspension systems indicated from the result that, the active and semi-active suspension systems provide better ride quality with regards to all the parameters measured than the passive suspension systems.

## References

- [1] Ankita Bhise, R. et al (2016). Comparison between Passive and Semi-Active Suspension Systems using Matlab/Simulink. IOSR Journal of Mechanical and Civil Engineering (IOSR-JMCE).
- [2] Ahmed, M. I., Hazlina, M. Y. & Rashid, M. M. (2016). Mathematical Modelling and Control of Active Suspension System for a Quarter Car Railway Vehicle. Malaysian Journal of Mathematical Sciences.
- [3] Ayman, A. A. and Farhan A. S. (2013). Vehicle Suspension Systems Control, a Review. International Journal of Control Automation and Systems. NSSN 2165-8285 (Online).
- [4] Mehmet A. (2020). Modelling of Vehicle Suspension System. Project Submitted to Trakya University.
- [5] Musa, M. B. et al (2015). Active Vehicle Suspension Control Using Full State-Feedback Controller. Journal of Advance Materials Research.  
<https://www.researchgate.net/publication/281998514>.
- [6] Rajesh Rajamani (2012). Vehicle Dynamics and Control, Second Edition. Springer New York Dordrecht Heidelberg, London. DOI 10.1007/978-1-4614-1433-9.
- [7] Sathishkumar P. et al (2014). Mathematical Modelling and Simulation of Quarter Car Vehicle Suspension. International Journal of Innovative Research in Science, Engineering and Technology
- [8] Samaneh, F. and Moarefianpur (2021). An Adaptive Approach for Vehicle Suspension System Control in Presence of Uncertainty and Unknown Actuator Time Delay. Taylor and Francis; Systems



Science and Control Engineering. <https://www.tandfonline.com/loi/tssc20>

- [9] Srikanth Raju M. & Mahmoud, C. (2020). Quarter and Full Car Models Optimisation of Passive and Active Suspension System Using Genetic Algorithm. School of Physics, Engineering and Computer Science, University of Hertfordshire, Hatfield, UK.
- [10] Tejas P. T. & Modi M. J. (2016). Mathematical Modelling and Simulation of A Simple Half Car Vibration Model. International Journal for Scientific Research and Development. ISSN Online: 2321-0613.
- [11] Zhi-Jun, F. et al (2017). Online Adaptive Optimal Control of Vehicle Active Suspension Systems Using Single Network Approximation Dynamics Programming. Mathematical Problems in Engineering. <https://doi.org/10.1155/2017/4575926>.