

Design and validation of a Cloth Face Covering (CFC) with low breathing resistance for sports practice

Original

Design and validation of a Cloth Face Covering (CFC) with low breathing resistance for sports practice / Ferri, Ada; Barla, Marco; Campagnaro, Cristian; Dotti, Francesca; Dugoni, Martina; Marchesa, Guglielmo; Mozzone, Daniele; Vallan, Alberto. - ELETTRONICO. - (2022), pp. 106-110. ((Intervento presentato al convegno 2022 IEEE International Workshop on Sport, Technology and Research (STAR) tenutosi a Trento - Cavalese (I) nel 06-08 July 2022 [10.1109/STAR53492.2022.9859588]).

Availability:

This version is available at: 11583/2971172 since: 2022-09-09T22:04:58Z

Publisher:

IEEE - Institute of Electrical and Electronics Engineers

Published

DOI:10.1109/STAR53492.2022.9859588

Terms of use:

openAccess

This article is made available under terms and conditions as specified in the corresponding bibliographic description in the repository

Publisher copyright

IEEE postprint/Author's Accepted Manuscript

©2022 IEEE. Personal use of this material is permitted. Permission from IEEE must be obtained for all other uses, in any current or future media, including reprinting/republishing this material for advertising or promotional purposes, creating new collecting works, for resale or lists, or reuse of any copyrighted component of this work in other works.

(Article begins on next page)

Design and validation of a Cloth Face Covering (CFC) with low breathing resistance for sports practice

1st Ada Ferri

*dept. Applied Science and Tech.
Politecnico di Torino
Turin, Italy
ada.ferri@polito.it*

2nd Marco Barla

*dept. Structural, Geotech. and Building Engin.
Politecnico di Torino
Turin, Italy
marco.barla@polito.it*

3rd Cristian Campagnaro

*dept. Architecture and Design
Politecnico di Torino
Turin, Italy
cristian.campagnaro@polito.it*

4th Francesca Dotti

*dept. Applied Science and Tech.
Politecnico di Torino
Turin, Italy
francesca.dotti@polito.it*

5th Martina Dugoni

*dept. Architecture and Design
Politecnico di Torino
Turin, Italy
martina.dugoni@polito.it*

6th Guglielmo Marchesa

*dept. Applied Science and Tech.
Politecnico di Torino
Turin, Italy
guglielmo.marchesa@polito.it*

7th Daniele Mozzone

*IMSTO
Istituto di Medicina dello Sport
Turin, Italy
dthelf55@gmail.com*

8th Alberto Vallan

*dept. Electronics and Telecommunications
Politecnico di Torino
Turin, Italy
alberto.vallan@polito.it*

Abstract—A Cloth Face Covering (CFC) to prevent the spread of SARS-COVID 2 was designed and tested with the aim of minimising interference with athletic performance. A highly rigid 3D mesh fabric was chosen as the reusable frame and an electrospun non-woven fabric as the replaceable filter. A product with extremely high breathability was developed that complies with the Italian standard UNI /PdR 90.1:2020. Measurements of the pressure in the dead space during sports practise confirmed the low breathing resistance of CFC. In maximal tests, no differences were found in maximum heart rate and duration of exertion, while the rate of perceived exertion (RPE) was slightly higher when wearing CFC compared to not wearing the mask.

Index Terms—Cloth face covering, breathing resistance, filtration, maximal test

I. INTRODUCTION

The combined use of vaccines and non pharmaceutical interventions has been shown to be an effective strategy to reduce the risk of infection with Severe Acute Respiratory Syndrome Coronavirus 2 (SARS-COVID 2) [1]. Among non pharmaceutical interventions, face masks are an effective means of preventing the spread of infection and are still used in many countries, especially indoors. Several studies show the benefits of wearing a mask for individual and community safety [2] [3]. However, face masks can heavy interfere with

everyday activities, especially sports [4]. Cloth face masks (CFCs) have become popular during the pandemic COVID for many reasons: shortage of certified devices such as surgical and FFP respirators, concern about the environmental impact of disposable masks [5], potential ingestion of microplastics when wearing a mask [6]. CFCs are not classified as medical devices or personal protective equipment, and the lack of testing and certification was one of the barriers limiting their use. However, some countries, including France and Italy, have developed new national standards for the testing of face masks, with specific requirements for use in sports [24] [25], and the CEN Workshop Agreement CWA 17553:2020 [7], which sets minimum requirements for test methods and the use of community face coverings was developed drafted in June 2020. With the same aim of providing guidelines for testing community face covering, ASTM F3502-21 [8] and BSI Flex 5555 [9] were published in 2021.

As ventilation increases dramatically during exercise, certified masks do not meet the needs of an athlete: surgical masks are flexible and easily deformed so that negative pressure during inhalation causes the mask to be sucked into the mouth; FFP respirators, while stiffer and thermoformed, are made of five layers of filtering non-woven fabric and have high breathing resistance. When selecting materials that offer an optimal balance between filtration efficiency and breathability, one can refer to the data recently presented by Bourrous S. et al [10]. In this study, 233 different fabrics (woven, non-woven, mixed)

This work has been supported by the Italian Ministry of University and Research (MUR) within the FISR2020 project “Development of a face mask for the prevention of hypercapnia in sport activities - FISR2020IP 03563 SHERPA”

were examined and the graph of filtration efficiency at $3\ \mu\text{m}$ versus air permeability was presented. For woven materials, high breathability was observed at the expense of filtration efficiency, as the two properties are strongly correlated. Non-woven fabrics had the highest filtration efficiency but were generally characterised by low breathability. Mixed fabrics, i.e. the combination of layers of woven and non-woven fabrics, guaranteed the highest breathability and, for some specific combinations, an acceptable filtration efficiency.

A mixed fabric was chosen for the development of the community face covering presented in this paper, as the main objective of this mask was to meet the needs of athletes during physical activities, favouring high breathability over high filtration. The main advantage of population masking is source control, i.e. the control of particles emitted by the wearer to protect others. If adherence is high, even small reductions in individual transmission with "imperfect" masks and face coverings could lead to large effects on population spread, especially in crowded indoor environments [11].

This paper reports on the effect of a face mask during maximal and submaximal physical activity and compares standardised face masks (surgical and FFP2) and a CFC with an electrospun replaceable filter specifically designed for sports practise. The CFC filter was tested for filtration efficiency and breathing resistance according to the Italian standard UNI/PdR 90:1-2:2020 [25]. During a submaximal test, pressure measurements were taken in the dead space of the mask, using surgical and FFP2 masks as a comparison. Finally, five athletes performed a maximal test with and without CFC to check for any impairment of athletic performance by the mask.

II. MATERIALS AND METHODS

Sherpa CFC was developed in Italy during the first wave of the pandemic outbreak (March-May 2020), when even outdoor sports required the wearing of a mask. It was marketed and used by athletes during training and competitions, especially basketball players. Based on feedback after use, an improved version of the mask was developed in 2022. It consists of two parts: a reusable frame and an electrospun replaceable filter. The frame is made of a polyester 3D mesh fabric (Tiba Tricot, basis weight: $148\ \text{g/m}^2$, air permeability $5.236 \cdot 10^6\ \text{l/s/m}^2$ according to UNI EN ISO 9237:97 [12], flexural rigidity $71\text{-}142\ \mu\text{J/m}$ according to ASTM D1388-18 [13]). Combining layers with stiffer materials for shaping has been reported in the literature as an option for CFC [14], and a 3D mesh fabric should meet the requirements of high stiffness and high air permeability.

Fig.1 shows the heart loop test to measure the stiffness of the mesh fabric. The test is based on measuring the length of the loop that a fabric strip forms under the action of gravity. Since fabrics are highly non-isotropic materials, flexural rigidity depends on the direction and the test was performed along the web course and the wale directions.

Several mesh fabrics were considered and the selected fabric was the optimal choice in terms of weight (fabrics weighing more than $200\ \text{g/m}^2$ were excluded because of poor wearing

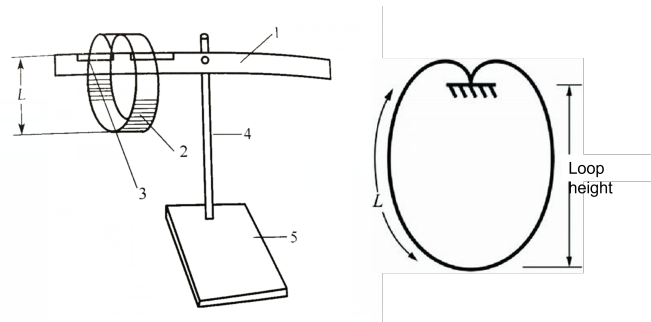

Fig. 1. Heart loop test for fabric stiffness.

comfort), air permeability and flexural rigidity.

The filter is a three-layer nonwoven fabric with a nanofiber layer sandwiched between two hydrophilic spunbonded layers (basis weight: $30\ \text{g/m}^2$, thickness $0.35\ \text{mm}$, particle filtration efficiency PFE 80%, breathing resistance $13\ \text{Pa/cm}^2$). The minimum particle filtration efficiency requirement for CFCs was set at 80% according to UNI/PdR 90:1:2020, a lower value than for certified surgical masks (minimum filtration efficiency BFE 95% according to BS EN 14683:2019 [15]) and FFP2 (minimum PFE 95% according to BS EN 149:2001 [16]), which are considered a compromise between filtration efficiency and breathing resistance. Adjustable elastic straps hold the CFC in place and guarantee the seal on the face during use (Fig. 2).



Fig. 2. Sherpa CFC worn by an athlete during maximal test.

The head harness is very important during training, as the mask must sit firmly on the face under all circumstances. An elastic strap with a slider allows the mask position to be adjusted and helps to seal the mask onto the face. Leakage from a non-sealing mask has been shown to be of

greater concern compared to respirators [17]. In addition, a randomised clinical trial [18] and a computational study [20] have demonstrated that leakage also depends on the position of the mask on the user's face and is thus influenced by the way it is worn and compliance with the manufacturer's instructions [17]. Leakage also depends on airflow, and it is reasonable that it is significantly higher, in term of absolute values, at high flow rates during exercise.

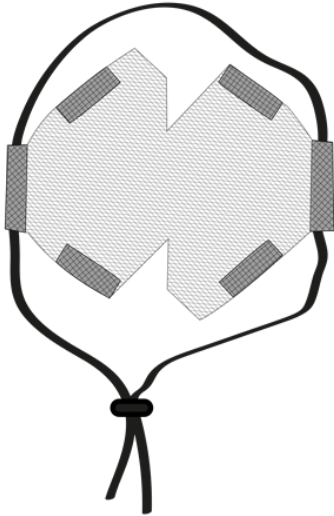

Fig. 3. Sherpa CFC design (flat for filter replacement) with velcros for 3D shaping.

The design of the Sherpa CFC is such that the mask is flat to facilitate filter replacement, while it seals on the face by superimposing two Velcro straps on the nose and chin, making the mask three-dimensional (Fig. 3).

III. RESULTS

Measurements of air permeability were made in accordance with ISO 9237:97 under the fixed gradient of 100 Pa (Table I). These data do not take into account leakage in real use, as the fabric sample is kept flat and sealed at the edge during the test.

TABLE I
AIR PERMEABILITY OF THE TESTED MASKS.

	FFP2	Surgical	CFC
Air permeability according to ISO 9237:97 expressed in (l/s/m ²) for a vacuum pressure of 100 Pa	69.7	112.0	605.0

According to CWA 17553:20, the differential pressure of the material should be less than or equal to 70 Pa/cm², which corresponds to about 80 l/s/m² at a vacuum pressure of 100 Pa. Sherpa CFC shows extremely high breathability in relation to the surgical mask and FFP2 respirator. This result confirms that mixed fabrics can achieve a level of breathability that cannot

be matched by conventional nonwovens such as those used in the surgical mask and FFP2 respirator. The CWA 17553 distinguishes two levels of CFCs according to their filtration efficiency for particles around 3 ($\pm 0,5$) μm : level 90% and level 70%. The Sherpa CFC filter material, with an efficiency of 96.7% for particles of 3.5 μm and an efficiency of 91.8% for particles of 2.5 μm , belongs to the first level according to CWA 17553:20. According to the Italian standard UNI/PdR 90:1, the cumulative efficiency for particles of different sizes was measured and a value of 80% was obtained, which is the minimum requirement of the Italian CFC standard. Comparing the air permeability and filtration efficiency results of Sherpa CFC with the literature data given in [10], it can be seen that Sherpa CFC mixed fabric achieves one of the highest air permeability and filtration efficiency among the tested materials.

Concentration of carbon dioxide in the dead space for Sherpa CFC, measured according to BS EN 149:2001 [16], was less than 1%.

To verify the performance of the CFC during use, a sub-maximal test was performed by a trained amateur athlete (49 years, height 175 cm, weight 73 kg, BMI 23.8, FTP 280W) on a Smart Trainer (Elite Drivo II). Table II shows the metabolic cost, ventilation and heart rate during a pre-test without mask at three incremental power levels (100 W, 150 W, 200 W). The duration of each phase was 3 minutes.

TABLE II
SUB-MAXIMAL TEST METABOLIC COST.

Power output (W)	Heart rate (bpm)	VE (l/min)	VO ₂ /kg (ml/min/kg)	VCO ₂ /kg (ml/min/kg)
101	91	18.7	20.6	16.9
151	104	37.5	27.2	24.8
200	119	57.9	35.1	34.6

The same submaximal test was repeated by the same tester with FFP2, surgical mask and Sherpa CFC.

In order to compare different masks under real conditions, a portable measure system which is able to measure pressure, CO₂ concentration and temperature inside the mask dead space was specifically developed [19] and a first prototype was employed in this test. Two sampling lines are employed to measure the quantities inside the mask and during the tests have been fixed just in front of the athlete's mouth using surgical tape, as shown in Fig. 5. The measurement system embeds a sensor pressure having a range of ± 500 Pa and a sampling rate of 20 Hz, high enough to record the mask pressure even under hard physical activity. Results obtained during the test are shown in Fig. 4. The test started after 1 min and was carried out at increasing physical intensity. Breathing rate and ventilation increases during the test and, as expected, pressure signal shows a larger peak-to-peak amplitude toward the end of the test. Air temperature follows the same behaviour since larger is the ventilation and larger is the temperature swing recorder in front of the mouth. Concerning the CO₂ concentration, the difference between the beginning and the

end of the test was not so relevant, probably because the CO₂ sampling line was in contact with the mask fabric and thus not able to sample the athlete inspired and expired air.

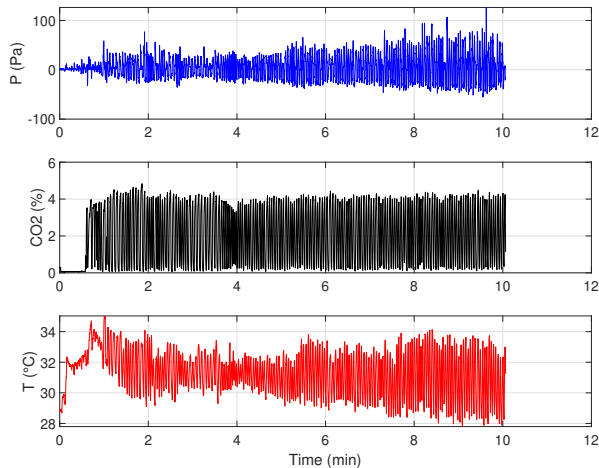

Fig. 4. Pressure, CO₂ concentration and temperature recorded inside the CFC mask during a submaximal test.

The most significant test outcome is the pressure measurement and Fig. 6 shows a comparison among the pressure evolution during the test at different physical intensities with different masks. The air permeability of the surgical mask is about five times lower than that of Sherpa CFC, but a pressure difference of about 25% was found in the dead space between Sherpa CFC compared to the surgical mask, whereas with the FFP2 respirators a significantly higher pressure was observed in the dead space. This result can be explained by leakage in the airflow, as the surgical mask is not face-tight, whereas CFC and, partially, the FFP2 are. Two routes for particle penetration have been confirmed in the literature (through the filter and through the face seal) and it has been demonstrated that face seal leakage is significantly higher in the surgical mask than in the N95 respirator [21].



Fig. 5. Sherpa CFC worn by an athlete during submaximal test. Sampling lines for the measurement of pressure and CO₂ concentration are routed inside the mask and their openings are in front of the mouth.

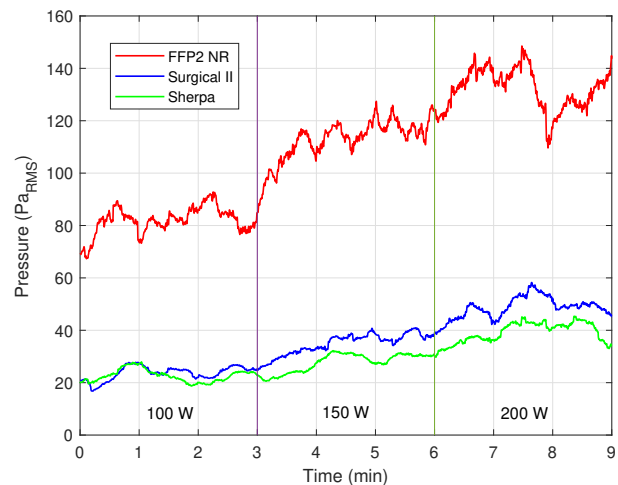

Fig. 6. Pressure in the dead space (Root Mean Square envelope using a sliding window of length 25 s).

Following the preliminary results on submaximal physical activity, a campaign of maximal tests was conducted to emphasise the effects of the masks on athletic performance. Five basketball players (21 ± 1 years, height 188 ± 6 cm, weight 81 ± 11 kg, BMI 22.8 ± 2.5) performed a maximal test according to the Bruce protocol treadmill test [22]. They performed two tests at the same time of day, 48 hours apart (to ensure full recovery), with and without CFC. Maximum heart rate and total test duration were monitored as an indicator of performance. The Rate of Perceived Exertion (RPE) was determined at the end of the test using the Borg scale [23]. Data were analysed using the Wilcoxon signed-rank test. Both maximum heart rate ($p = 0.5879$) and duration ($p = 0.8125$) showed no significant differences with and without mask. Perceived exertion was higher with CFC, and mean RPE was 1.4 points higher with CFC (17.6 vs 16.2). The results of the maximal tests indicated that athletic performance was not significantly affected by Sherpa CFC, with comparable total duration of the maximal test. However, perceived exertion was generally greater with the mask ($p = 0.1736$), likely due to a greater effort of the respiratory muscles to ventilate the high flow rate through the CFC.

ACKNOWLEDGEMENT

The authors would like to thank Stamperia Alicese for tailoring the prototypes, UFI for developing the replaceable filter, Prof. Tronville for conducting the particle filtration efficiency test and Tam Tam ASD, the basketball team, for kindly providing the athletes for the maximal tests.

REFERENCES

- [1] Rowan, N. J., Moral, R. A. (2021). Disposable face masks and reusable face coverings as non-pharmaceutical interventions (NPIs) to prevent transmission of SARS-CoV-2 variants that cause coronavirus disease (COVID-19): Role of new sustainable NPI design innovations and predictive mathematical modelling. *The Science of the total environment*, 772, 145530. <https://doi.org/10.1016/j.scitotenv.2021.145530>

- [2] Tabatabaeizadeh S. A. (2021). Airborne transmission of COVID-19 and the role of face mask to prevent it: a systematic review and meta-analysis. *European journal of medical research*, 26(1), 1. <https://doi.org/10.1186/s40001-020-00475-6>
- [3] Asadi, S., Cappa, C. D., Barreda, S., Wexler, A. S., Bouvier, N. M., Ristenpart, W. D. (2020). Efficacy of masks and face coverings in controlling outward aerosol particle emission from expiratory activities. *Scientific reports*, 10(1), 15665. <https://doi.org/10.1038/s41598-020-72798-7>
- [4] Egger, F., Blumenauer, D., Fischer, P., Venhorst, A., Kulenthiran, S., Bewarder, Y., Zimmer, A., Böhm, M., Meyer, T., Mahfoud, F. (2022). Effects of face masks on performance and cardiorespiratory response in well-trained athletes. *Clinical research in cardiology : official journal of the German Cardiac Society*, 111(3), 264–271. <https://doi.org/10.1007/s00392-021-01877-0>
- [5] Dharmaraj, S., Ashokkumar, V., Hariharan, S., Manibharathi, A., Show, P. L., Chong, C. T., Ngamcharussrivichai, C. (2021). The COVID-19 pandemic face mask waste: A blooming threat to the marine environment. *Chemosphere*, 272, 129601. <https://doi.org/10.1016/j.chemosphere.2021.129601>
- [6] Li, L., Zhao, X., Li, Z., Song, K. (2021). COVID-19: Performance study of microplastic inhalation risk posed by wearing masks. *Journal of hazardous materials*, 411, 124955. <https://doi.org/10.1016/j.jhazmat.2020.124955>
- [7] Community face coverings - Guide to minimum requirements, methods of testing and use, CEN CWA 17553:2020 (2020).
- [8] Standard Specification for Barrier Face Covering, ASTM F3502-21 (2021).
- [9] Community Face Coverings – Specifications, BSI Flex 5555 (2021).
- [10] Bourrous, S., Barrault, M., Mocho, V., Poirier, S., Bardin-Monnier, N., Charvet, A., Thomas, D., Bescond, A., Fouqueau, A., Macé, T., Gaielevrel, F., Ouf, F.X. (2021). A Performance Evaluation and Inter-laboratory Comparison of Community Face Coverings Media in the Context of COVID-19 Pandemic. *Aerosol and Air Quality Research*, 21, 200615. <https://doi.org/10.4209/aaqr.200615>
- [11] Czypionka, T., Greenhalgh, T., Bassler, D., Bryant, M. B. (2021). Masks and Face Coverings for the Lay Public : A Narrative Update. *Annals of internal medicine*, 174(4), 511–520. <https://doi.org/10.7326/M20-6625>
- [12] Textiles. Determination of the permeability of fabrics to air, BS EN ISO 9237:1995 (1995).
- [13] Standard test method for stiffness of fabrics, ASTM D1388-18 (2018).
- [14] Varallyay, C., Li, N. P., Case, B., Wolf, B. (2021). Material Suitability Testing for Nonmedical Grade Community Face Masks to Decrease Viral Transmission During a Pandemic. *Disaster medicine and public health preparedness*, 15(5), e26–e32. <https://doi.org/10.1017/dmp.2020.262>
- [15] Medical Face masks. Requirements and test methods, BS EN 14683:2019 (2019).
- [16] Respiratory protective devices – Filtering half masks to protect against particles – Requirements, testing, marking, BS EN 149:2001+A1:2009 (2009).
- [17] Chiera, S., Cristoforetti, A., Benedetti, L., Nollo, G., Borro, L., Mazzei, L., Tessarolo, F. (2022). A Simple Method to Quantify Outward Leakage of Medical Face Masks and Barrier Face Coverings: Implication for the Overall Filtration Efficiency. *International journal of environmental research and public health*, 19(6), 3548. <https://doi.org/10.3390/ijerph19063548>
- [18] Pettit, N., Zaidi, A., O'Neill, B., Doehring, M. (2022). Use of Adhesive Tape to Facilitate Optimal Mask Positioning and Use in the Emergency Department: A Randomized Controlled Trial. *Annals of emergency medicine*, 79(1), 58–63.e1. <https://doi.org/10.1016/j.annemergmed.2021.06.004>
- [19] Vallan A., Carullo A., Midolo L. and Ferri A., A portable system for CO2 and pressure monitoring inside the dead space of face masks. *IEEE MeMeA 2022*, in press.
- [20] Schmitt, J., Wang, J. (2021). Quantitative modeling of the impact of facemasks and associated leakage on the airborne transmission of SARS-CoV-2. *Scientific reports*, 11(1), 19403. <https://doi.org/10.1038/s41598-021-98895-9>
- [21] Grinshpun, S. A., Haruta, H., Eninger, R. M., Reponen, T., McKay, R. T., Lee, S. A. (2009). Performance of an N95 filtering facepiece particulate respirator and a surgical mask during human breathing: two pathways for particle penetration. *Journal of occupational and environmental hygiene*, 6(10), 593–603. <https://doi.org/10.1080/15459620903120086>
- [22] BRUCE, R. A., LOVEJOY, F. W., Jr (1949). Normal respiratory and circulatory pathways of adaptation in exercise. *The Journal of clinical investigation*, 28(6 Pt 2), 1423–1430. <https://doi.org/10.1172/JCI102207>
- [23] Borg, Gunnar. (1998). Borg's Perceived Exertion And Pain Scales.
- [24] Masques barrières pour le sport - Guide d'exigences minimales, de méthodes d'essais et d'usage, AFNOR SPEC S70-001 (2021).
- [25] Maschere di comunità - Parte I: Requisiti, tipologia e marcatura, UNI/PdR 90:1 (2020).