

2022

## Overarching Preventive Sympathetic Tripping Approach in Active Distribution Networks Without Telecommunication Platforms and Additional Protective Devices

Tahereh Dehghani Firouzabadi

Davoud Abootorabi Zarchi

Mohammadreza Mazid

*See next page for additional authors*

Follow this and additional works at: <https://arrow.tudublin.ie/engscheleart2>



Part of the [Electrical and Computer Engineering Commons](#)

---

This Article is brought to you for free and open access by the School of Electrical and Electronic Engineering at ARROW@TU Dublin. It has been accepted for inclusion in Articles by an authorized administrator of ARROW@TU Dublin. For more information, please contact [arrow.admin@tudublin.ie](mailto:arrow.admin@tudublin.ie), [aisling.coyne@tudublin.ie](mailto:aisling.coyne@tudublin.ie), [gerard.connolly@tudublin.ie](mailto:gerard.connolly@tudublin.ie).



This work is licensed under a [Creative Commons Attribution-NonCommercial-Share Alike 4.0 License](#)

---

**Authors**

Tahereh Dehghani Firouzabadi, Davoud Abootorabi Zarchi, Mohammadreza Mazid, Hadi Safdarkhani, and Hamed Nafisi

---

Received February 1, 2022, accepted February 14, 2022, date of publication February 22, 2022, date of current version March 18, 2022.

Digital Object Identifier 10.1109/ACCESS.2022.3153351

# Overarching Preventive Sympathetic Tripping Approach in Active Distribution Networks Without Telecommunication Platforms and Additional Protective Devices

TAHEREH DEGHANI FIROUZABADI<sup>1</sup>, DAVOUD ABOOTORABI ZARCHI<sup>1</sup>,  
MOHAMMADREZA MAZID<sup>1</sup>, HADI SAFDARKHANI<sup>1</sup>, AND HAMED NAFISI<sup>2,3</sup>

<sup>1</sup>Department of Electrical Engineering, Yazd University, Yazd 8915818411, Iran

<sup>2</sup>School of Electronics and Electrical Engineering, Technological University Dublin (TU Dublin), Dublin 15, D07 EWW4 Ireland

<sup>3</sup>Department of Electrical Engineering, Amirkabir University of Technology (Tehran Polytechnic), Tehran 15875-4413, Iran

Corresponding authors: Davoud Abootorabi Zarchi (d.abootorabi@yazd.ac.ir) and Hamed Nafisi (hamed.nafisi@TUDublin.ie)

**ABSTRACT** Nowadays, distributed generation (DG) has made it possible to generate electricity close to the consumption site, resulting in improved efficiency, less environmental pollution, and higher economic profit. These advantages have led to increased penetration of DGs in the distribution system. Protective devices in a distribution system are set by considering the main substation as the only source for feeding short circuit current. However, with the increased influence of DGs as the second main source of short circuit current in distribution systems the short circuit level changes, which leads to false tripping of protective devices, including overcurrent relays. A sympathetic trip, occurring due to a fault in the adjacent feeder, is one of the most serious challenges. This paper analyzes the sympathetic trip in the presence of synchronous based DGs. The equations related to the participation of DGs and upstream network in feeding the short circuit current are obtained. The effect of different parameters on the probability of occurrence of a sympathetic trip is also investigated. Moreover, a novel fast solution is presented for overcoming the sympathetic trip of synchronous based DGs. The proposed method is introduced using the positive-sequence currents of the DGs and main substation. The sympathetic trip is predicted by adopting this prediction index and its occurrence is avoided. The proposed methodology is independent of telecommunication platforms and additional protective devices and can be applied to various short circuits. The method is tested on a network by simulating in DIGSILENT PowerFactory software. Simulation results show the effectiveness of the proposed methodology in predicting and preventing sympathetic trips.


**INDEX TERMS** Distributed generation, distribution network, false tripping, overcurrent relay, positive sequence network, sympathetic tripping, short circuit current.

## I. INTRODUCTION

Distribution systems, as part of the power system, play a key role in power distribution, and the occurrence of any problems in the protection systems and equipments of this part of the power system, disrupts the process of power transmission to customers. For this reason, the factors that cause failures in protective devices must be identified and eliminated. One of these factors is the phenomenon of the sympathetic trip. The sympathetic trip is an incorrect disconnection of a healthy

feeder, which occurs for reasons such as no-load transformer energizing, presence of Distributed Generations (DGs), and delay in voltage recovery [1]–[3]. Other factors such as voltage dip imbalance, capacitor discharge current, and magnetic coupling between conductors of a cavity due to asymmetric fault have also been mentioned in the literature as causes of the sympathetic trip [4]. This study aims to investigate the sympathetic trip phenomenon in the distribution system with the presence of DGs.

Protection systems are designed based on radial current and line short circuit current for the normal operation of the distribution system. When a fault occurs in the network,

The associate editor coordinating the review of this manuscript and approving it for publication was Ali Raza .

in addition to the upstream network, the fault current is also fed by DGs and therefore, the short circuit current of upstream network is reduced, the short circuit level of the network is increased, and changes the direction of the current of feeders [5]. Protection problems such as blinding protection, sympathetic trip, loss of fuse-recloser coordination, unintentional islanding, and under-reach of protective devices occur due to changes in the short circuit level of the network [4]–[6], [8]–[10]. It should be mentioned that type, size, and location of DGs determine their contribution in short circuit current [6].

Following a fault in a distribution network in the presence of DGs, the relay associated with the fault is expected to trip. If the related relay does not trip and DG feeder protection relay that is not associated with the fault operates, this causes unwanted loss of an unfaulted line which is not desirable. This phenomenon of incorrect relay operation is named sympathetic tripping in the presence of DGs. Various methods have been proposed to prevent sympathetic trips in the presence of DG. Most solutions are based on changing the overcurrent relay settings; that is, the pickup current and time dial or the use of equipment to increase the short circuit impedance and thus reduce the short circuit current of the network and DG. Reference [11] provides a smart protection network that detects the fault location by using overhead and directional overcurrent relays and sends the settings to the nearest relay to disconnect the smallest part of the network. To prevent sympathetic trip, a method is proposed by calculating the root mean square (RMS) value of discrete wavelet energy gradient using current and voltage signals of the DG. In this method, using the simulation results, the threshold value for the rms value of the discrete wavelet gradient is determined, which detects whether a fault has occurred on the DG feeder or in the adjacent feeder. Accordingly, the sympathetic trip is prevented [12]. The adoption of equipment such as a 1:1 transformer to connect large DGs to the grid, fault current limiting reactors, and fault current limiters (FCL) increases the network impedance and thus reduces the short circuit current. Fault current limiting reactor during normal network operation increases network losses; however, the FCL has no additional losses. Using inverter-based DG is another solution as it has the least contribution to the fault current feeding. Installation of series fault current limiting reactor with DG to increase short circuit impedance and thus reduce DG short circuit current is also one of the ways to prevent sympathetic trip [8]. Adaptive protective methods are presented according to the network configuration to reduce the operating time of protective devices for fault clearance reasons [13]–[15]. In the adaptive protection method, with any changes in the network configuration, the relay settings are calculated and sent through the telecommunication platform using the proposed algorithms to minimize the fault clearance time. In [13], the objective function for optimization is to minimize the total operating time of the primary relays. However, the objective function in [14] is to minimize the

operating times of the primary and backup relay pairs, and the problem deals with the number of primary-backup relay pairs as the objective function. In [15], the optimal settings of overcurrent relays are calculated by considering faults in different locations using the downstream-upstream method. A method using positive and negative sequence currents is also presented [16]. In fact, the proposed algorithm for detecting sympathetic trips in the presence of DG has only been investigated to detect line-to-line (LL) short circuits. In this method, positive and negative sequence currents of the DG and changes of both are measured. Considering the values of the positive to negative sequence current ratio and the ratio of positive sequence current changes to negative sequence current changes, it detects experimentally whether the fault has occurred in the DG adjacent feeder or downstream of DG. Another solution is to increase the pickup current of the overcurrent relay. A sympathetic trip may be avoided by increasing the pickup current; nonetheless, the sensitivity of the protective device decreases and some faults cannot be detected. Another and better solution would be to increase the fault clearance time [13]. In this case, first, the faulty feeder is disconnected and the healthy feeder is prevented from disconnection. Directional relays can also be used without changing the relay settings. The overcurrent relay measures the short-circuit current and the direction of the power flow and operates if the current is greater than the pickup current and the power flow is in a certain direction. Nevertheless, these relays are expensive and relatively slow [2]. Reference [17] presents adaptive protection using fast recursive discrete Fourier transform and fuzzy-logic decision module. In [5], the sympathetic tripping of DG and retrieved the formulations for sinusoidal steady state. However, formulation for the sympathetic tripping of DG should be developed in transient condition. Reference [18] proposed a method for sympathetic tripping in distribution networks with Photovoltaic DGs based on the IEC 61850 standard. This method requires to exchange message between agents which limits its application in real application. In [19], different types of faults, fault locations and loads were compared and studied. The results showed that the delayed voltage recovery following a phase-to-phase or three-phase fault can lead to the sympathetic trip of an adjacent feeder with high percentage of motor loads. In [20], application of machine learning based method was studied to prevent sympathetic tripping in distribution networks. In [4], a blocking logic scheme was proposed to detect the sympathetic tripping phenomena using the existing features of relays. Similarly, in [21], a blocking logic scheme is investigated to prevent sympathetic tripping of overcurrent relays during the fault induced delayed voltage recovery condition. Reference [22], an adaptive protection scheme was proposed to prevent sympathetic tripping in distribution networks.

Table 1 compares the proposed method in this paper with other methods and shows the superiority of the proposed method over them.

**TABLE 1. Comparison of the proposed method with other methods in terms of prevention of sympathetic trip.**

Methods	Setting changes of protective devices	Need for a telecommunication platform	Additional protective devices	Applicable for various short circuits	Dependence on network configuration
Proposed method				*	*
Ref. [7]	*	*	*	*	*
Refs. [13-15]	*	*		*	*
Ref. [16]					*
Ref. [2]	*		*		*
Ref. [22]	*	*	*		*

The main contributions of this study are as follows:

- Based of our knowledge, a novel formulation is obtained in this paper for the DG current and the main substation current in the case of the sympathetic trip.

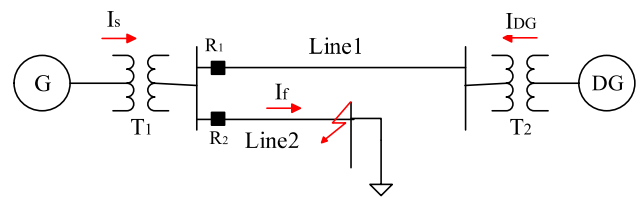
- A new methodology is proposed to prevent sympathetic trips in the presence of DG, which can detect the fault location in the DG feeder or the adjacent feeder. This method has advantages as follows: it is used for four different types of faults including single-line to ground (LG), line-to-line (LL), line-to-line to ground (LLG), and three-phase (LLL) faults with a high presence of DG. By Simulating the considered network and the application of the proposed method, the sympathetic trip is predicted in all cases and its occurrence is prevented.

- In this methodology, no additional telecommunication platform and protective devices is needed; only the current of the DG units and the main substation is required and the settings of the protective devices are not changed.

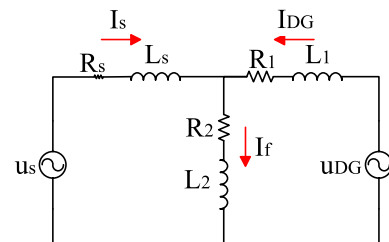
In Section 2, a formulation for the phenomenon of the sympathetic trip is presented simultaneously with the simplified network. Also, the effect of different parameters on the probability of occurrence of this phenomenon has been investigated. The theory and mathematical relations of the proposed algorithm are presented in Section 3. Section 4 analyzes the simulation results by applying the proposed method to a test network using DIgSILENT PowerFactory software. Section 5 provides the conclusions of this study.

## II. IMPACT OF DIFFERENT PARAMETERS ON THE PROBABILITY OF OCCURRENCE OF SYMPATHETIC TRIPPING

A sympathetic trip is the incorrect disconnection of one part of the network due to a fault occurring in another part of the network. With the presence of DG in the distribution system, in the event of a fault in adjacent feeders, the DGs feed part of the fault current through a common bus. As shown in Fig. 1, if the current of the DG-connected feeder exceeds the regulating current of the feeder relay, the overcurrent relay  $R_1$



**FIGURE 1. DG involvement in feeding the fault current.**



**FIGURE 2. Equivalent circuit of Fig. 1.**

may operate faster than the relay  $R_2$  and the DG-connected feeder may be disconnected incorrectly.

As shown in Fig. 1, when a fault occurs in Line 2, part of the fault current is supplied by the DG and the other part by the external network. Depending on the different parameters of the system, each provides some amount of fault current. To investigate the effect of different parameters on the probability of sympathetic trip, the relationship between the fault currents of the DG and the external network is calculated by considering the network in Fig. 1.

Fig. 2. Shows the equivalent circuit of the network, where the DG and the main substation are assumed as sinusoidal sources. Using Kirchoff’s voltage and current laws (KVL and KCL), Eqs. (1)-(3) are expressed.

$$u_s(t) = u_s \sin(\omega t) \text{ and } u_{DG}(t) = u_{DG} \sin(\omega t)$$

$Z_s = R_s + j\omega L_s$  is the equivalent impedance of the upstream network and transformer  $T_1$ .

$Z_1 = R_1 + j\omega L_1$  is the equivalent impedance of the DG unit, the transformer  $T_2$ , and Line 1.

$Z_2 = R_2 + j\omega L_2$  is the equivalent impedance of Line 2 and the short circuit.

$$R_1 \approx R_2 = R \text{ and } L_1 \approx L_2 = L.$$

$$\begin{cases} u_s = R_s i_s + L_s \frac{di_s}{dt} + R i_f + L \frac{di_f}{dt} & (1) \\ u_{DG} = R i_{DG} + L \frac{di_{DG}}{dt} + R i_f + L \frac{di_f}{dt} & (2) \\ i_f = i_{DG} + i_s & (3) \end{cases}$$

Taking the Laplace transform of Eqs. (1)-(3), Equations (4)-(6) are obtained by solving the equations in the Laplace and inverse Laplace domains.

Equations (4)-(6) represent short circuit currents of DG, fault location, and upstream network considering a three-phase fault in the symmetric network. The currents comprise three components; one sinusoidal component related to the DG and main substation and two decaying DC components with time constants of  $(L + 2L_s)/(R + 2R_s)$  and  $L/R$  respectively. The decaying rate of the first component is faster than that of the second component. As per Eq. (4), if the DC component of the DG's short-circuit current is significant, this circuit surpasses the threshold value of overcurrent protection. If the DC protection device trips faster than the protection device of faulty feeder, a sympathetic trip will occur.

$$\begin{aligned} i_{DG}(t) &= -\frac{(\omega \cos \omega t - \frac{R+2R_s}{L+2L_s} \sin \omega t - \omega e^{-\frac{R+2R_s}{L+2L_s}t})}{2(L+2L)\left(\omega^2 + \left(\frac{R+2R_s}{L+2L_s}\right)^2\right)} (u_{DG} - 2u_s) \\ &\quad - \frac{(\omega \cos \omega t - \frac{R}{L} \sin \omega t - \omega e^{-\frac{R}{L}t})}{2L\left(\omega^2 + \left(\frac{R}{L}\right)^2\right)} u_{DG} \\ &\quad + \frac{1}{2}e^{-\frac{R}{L}t} (i_{DG}(0) + i_f(0)) + \frac{1}{2}e^{-\frac{R+2R_s}{L+2L_s}t} (i_{DG}(0) - i_f(0)) \end{aligned} \quad (4)$$

$$\begin{aligned} i_f(t) &= \frac{(\omega \cos \omega t - \frac{R+2R_s}{L+2L_s} \sin \omega t - \omega e^{-\frac{R+2R_s}{L+2L_s}t})}{2(L+2L_s)\left(\omega^2 + \left(\frac{R+2R_s}{L+2L_s}\right)^2\right)} (u_{DG} - 2u_s) \\ &\quad - \frac{(\omega \cos \omega t - \frac{R}{L} \sin \omega t - \omega e^{-\frac{R}{L}t})}{2L\left(\omega^2 + \left(\frac{R}{L}\right)^2\right)} u_{DG} \\ &\quad + \frac{1}{2}e^{-\frac{R}{L}t} (i_{DG}(0) + i_f(0)) - \frac{1}{2}e^{-\frac{R+2R_s}{L+2L_s}t} (i_{DG}(0) - i_f(0)) \end{aligned} \quad (5)$$

$$\begin{aligned} i_s(t) &= \frac{(\omega \cos \omega t - \frac{R+2R_s}{L+2L_s} \sin \omega t - \omega e^{-\frac{R+2R_s}{L+2L_s}t})}{(L+2L_s)\left(\omega^2 + \left(\frac{R+2R_s}{L+2L_s}\right)^2\right)} (u_{DG} - 2u_s) \\ &\quad - e^{-\frac{R+2R_s}{L+2L_s}t} (i_{DG}(0) - i_f(0)) \end{aligned} \quad (6)$$

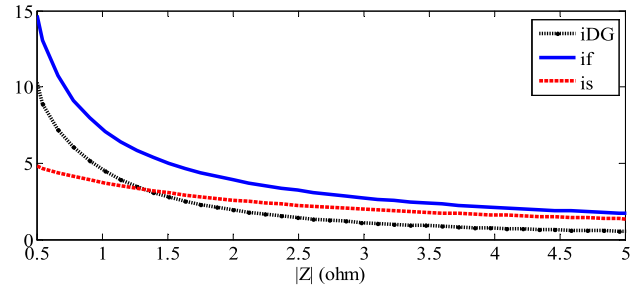


FIGURE 3. Maximum short-circuit current in terms of the distance between the DG and fault location from the common bus.

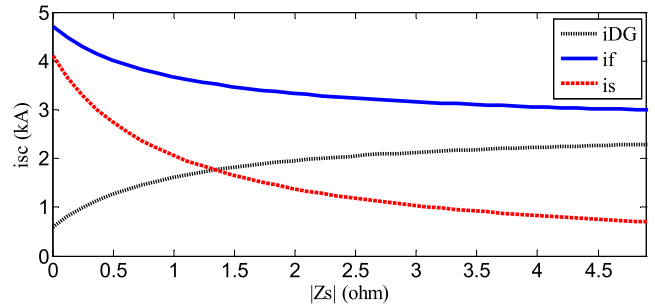


FIGURE 4. Maximum short-circuit current in terms of source impedance.

To analyze the impact of different parameters on the probability of occurrence of a sympathetic trip, the maximum short-circuit current, given in Eqs. (4)-(6), is depicted in Figs. 3 and 4 by changing the impedance of the upstream network and the distance between the fault location and the DG.

Additionally, short-circuit currents in the phasor domain are expressed in Eqs. (7)-(9) assuming  $U_s = U_{DG} = E$ . According to Figs. (3)-(4) and Eqs. (7)-(9), increasing the distance between the DG or the fault location and the common bus increases the impedance  $z$ , while currents  $i_{DG}$ ,  $i_f$ , and  $i_s$  are reduced and the probability of occurrence of a sympathetic trip is reduced as well. Increasing the source impedance ( $z_s$ ) leads to a reduction in currents  $i_s$  and an increase in current  $i_{DG}$ , while the sympathetic trip becomes more probable.

$$I_s = \frac{2U_s - U_{DG}}{z + 2z_s} = \frac{E}{z + 2z_s} \quad (7)$$

$$I_{DG} = \frac{U_{DG}}{z + \frac{z \cdot z_s}{z + z_s}} - \frac{U_s}{z + 2z_s} = \frac{E}{z(\frac{z}{z_s} + 2)} \quad (8)$$

$$I_f = \frac{z_s U_{DG}}{z(z + 2z_s)} + \frac{U_s}{z + 2z_s} \quad (9)$$

Other parameters such as size and type of DG and external network short-circuit ratio also affect on the probability of occurrence of a sympathetic trip [15], [16]. With increasing the external short-circuit ratio, the fault current fed by the network increases; thus, the protection device of the faulty feeder acts faster and prevents the sympathetic trip. Likewise, with increasing the size of DG, its participation in feeding the fault current rises and therefore, the probability of a sympathetic trip increases [23]. Reference [24] addresses the



impact of DG type on the fault current. Participation of a synchronous generator in fault current is greater than that of an induction generator. Inverter-based DGs have the least possible involvement in feeding fault current and most of the short-circuit current are supplied by the network; thus, a sympathetic trip is avoided under such conditions.

### III. THE PROPOSED ALGORITHM FOR DETECTION AND PREVENTION OF SYMPATHETIC TRIPPING

Considering the circuit in Fig. 5, three cases are taken into account for a fault in the network: 1) Fault on the adjacent feeder downstream of the DG (Line 1), 2) Fault on the adjacent feeder upstream of the DG (Line 3), and 3) Fault on the DG-connected feeder (Line 2). In case a fault occurs on Line 1, the protection device of DG may act faster than the near-end relay of the line ( $R_1$ ) due to the participation of DG in feeding the short-circuit current, and the DG unit may be disconnected mistakenly. Furthermore, when a fault occurs on Line 3, the DG unit feeds part of the short-circuit current through the common bus. In this case, the DG protection device or the relay at the near-end of the DG-connected feeder may trip faster than the faulty relay and a sympathetic trip would occur.

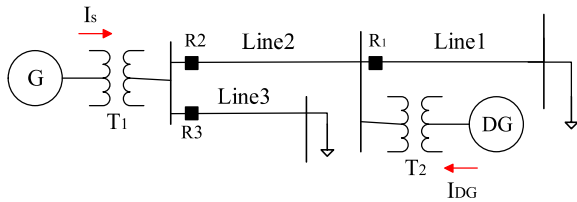


FIGURE 5. A distribution system in the presence of a DG.

Short circuits in the distribution system are generally divided into four categories: single-line to ground (LG), double-line (LL), double-line to ground (LLG), and three-phase (LLL) faults [10]. The proposed method in this study is applied to all four types. Positive-sequence currents of the DG unit and main substation are used in this method. Each of the positive-sequence currents can be calculated using positive-sequence circuits [25].

Considering the positive-sequence equivalent circuit of the network for each of the three cases abovementioned, positive-sequence currents of the DG and the upstream network together with the index  $K \triangleq I_{DG}^1/I_s^1$  are calculated. Using the index  $K$ , one can detect the type of fault. In case the fault is identified in the adjacent feeders, the protection function of the DG or the relay of the DG-connected feeder can be locked for a given interval so that the occurrence of a sympathetic trip is prevented. Noted that the DGs and feeders are modeled as synchronous generator and short distance line, respectively.

#### A. A FAULT IN THE ADJACENT FEEDER DOWNSTREAM OF THE DG

Assume that a short circuit occurs on Line 1. Fig. 6 shows the positive-sequence equivalent circuit of the network.

Positive-sequence currents of the DG and the external network are obtained by dividing current  $I_1$ , Eqs. (10)-(11) [26]. An auxiliary index  $K \triangleq I_{DG}^1/I_s^1$  is defined, which is a suitable criterion for detecting the fault location and for preventing the sympathetic trip. In Fig. 6,  $Z_f$  is the fault impedance. The positive sequence current ( $I_1$ ) is related to  $Z_f$  in location of fault. However, as indicated in (12), (15), and (18)  $K$  has been defined as the ratio of positive sequence currents which leads to removing  $I_1$  in numerator and denominator. Therefore, the fault resistance does not have any effect on the results.

$$I_{DG}^1 = I_1 \times \frac{(Z_s^1 \parallel Z_{L3}^1) + Z_{L2}^1}{(Z_s^1 \parallel Z_{L3}^1) + Z_{L2}^1 + Z_{DG}^1} \quad (10)$$

$$I_s^1 = I_1 \times \frac{Z_{DG}^1}{(Z_s^1 \parallel Z_{L3}^1) + Z_{L2}^1 + Z_{DG}^1} \times \frac{Z_{L3}^1}{Z_{L3}^1 + Z_s^1} \quad (11)$$

$$K \triangleq \frac{I_{DG}^1}{I_s^1} = \frac{Z_s^1 + Z_{L2}^1 (1 + \frac{Z_s^1}{Z_{L3}^1})}{Z_{DG}^1} \quad (12)$$

$Z_{L2}^1$ : Positive-sequence impedance of line L2

$Z_{L3}^1$ : Positive-sequence impedance of line L3

$Z_s^1$ : Sum of positive-sequence impedances of the external network and the substation transformer

$Z_{DG}^1$ : Sum of impedances of the DG and the connecting transformer

$I_1$ : Positive-sequence current of a short circuit at the fault location

$I_{DG}^1$ : Positive-sequence current of a short circuit at the DG location

$I_s^1$ : Positive-sequence current of a short circuit at the upstream network.

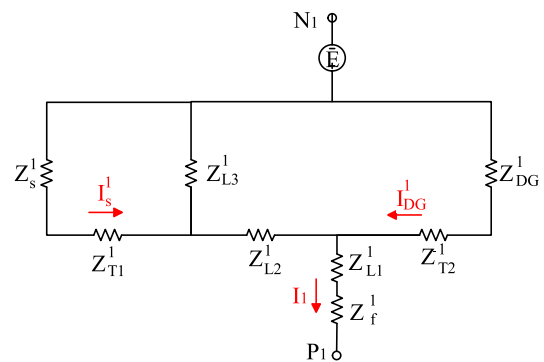


FIGURE 6. Positive-sequence equivalent circuit 1 of Fig. 5 considering a fault on Line 1.

#### B. A FAULT ON THE ADJACENT FEEDER UPSTREAM OF THE DG

Fig. 7 illustrates the positive-sequence equivalent circuit of Fig. 5 by considering a short circuit fault on the upstream adjacent feeder (Line 3). The contributions of the DG and the external network to feeding the positive-sequence current are calculated using Eqs. (13) and (14), respectively.

Equation (15) gives the calculation of index  $K$ . In this case, again the value of  $K$  is independent of fault location.

$$I_{DG}^1 = I_1 \times \frac{Z_s^1}{(Z_{DG}^1 \parallel Z_{L1}^1) + Z_{L2}^1 + Z_s^1} \times \frac{Z_{L1}^1}{Z_{L1}^1 + Z_{DG}^1} \quad (13)$$

$$I_s^1 = I_1 \times \frac{(Z_{DG}^1 \parallel Z_{L1}^1) + Z_{L2}^1}{(Z_{DG}^1 \parallel Z_{L1}^1) + Z_{L2}^1 + Z_s^1} \quad (14)$$

$$K \frac{I_{DG}^1}{I_s^1} \triangleq \frac{Z_s^1}{Z_{DG}^1 + Z_{L2}^1 (1 + \frac{Z_{DG}^1}{Z_{L1}^1})} \quad (15)$$

$Z_{L1}^1$ : Positive-sequence impedance of line L1.

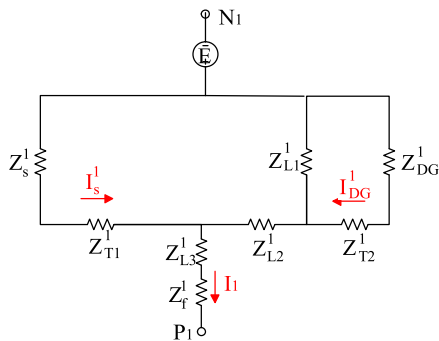


FIGURE 7. Positive-sequence equivalent circuit of Fig. 5 considering a fault on Line 3.

### C. A FAULT ON THE DG-CONNECTED FEEDER

Assume a short circuit fault on the DG-connected feeder (Line 2). In this case, similar to the previous case and by depicting the positive-sequence equivalent circuit (Fig. 8), positive-sequence currents of DG and external network are obtained by current division (Eqs. (16)-(17)). Index  $K$  is found from Eq. (18).

$$I_{DG}^1 = I_1 \times \frac{(Z_s^1 \parallel Z_{L3}^1) + \lambda Z_{L2}^1}{(Z_{DG}^1 \parallel Z_{L1}^1) + Z_{L2}^1 + (Z_s^1 \parallel Z_{L3}^1)} \times \frac{Z_{L1}^1}{Z_{L1}^1 + Z_{DG}^1} \quad (16)$$

$$I_s^1 = I_1 \times \frac{(Z_{DG}^1 \parallel Z_{L1}^1) + (1 - \lambda) Z_{L2}^1}{(Z_{DG}^1 \parallel Z_{L1}^1) + Z_{L2}^1 + (Z_s^1 \parallel Z_{L3}^1)} \times \frac{Z_{L3}^1}{Z_{L3}^1 + Z_s^1} \quad (17)$$

$$K \triangleq \frac{I_{DG}^1}{I_s^1} = \frac{Z_s^1 + \lambda Z_{L2}^1 (1 + \frac{Z_s^1}{Z_{L3}^1})}{Z_{DG}^1 + (1 - \lambda) Z_{L2}^1 (1 + \frac{Z_{DG}^1}{Z_{L1}^1})} \quad (18)$$

$\lambda$ : the distance between the fault location and main substation (%)

Based on Eq. (18), in this case, index  $K$  changes by varying the fault location. The values of this index for  $\lambda = 0$  (fault on the main substation) and  $\lambda = 1$  (fault on the far-end of Line 2) are presented in Eqs. (19) and (20), respectively. These values

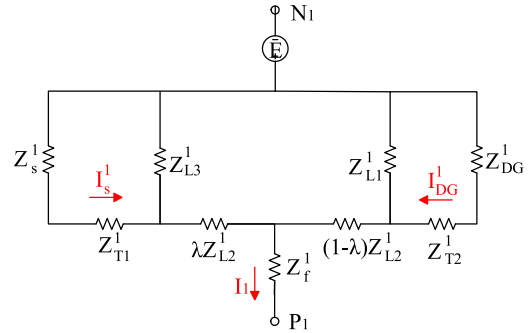


FIGURE 8. Positive-sequence equivalent circuit of Fig. 5 considering a fault on line  $L_2$ .

are used for depicting the curve of  $K$  vs fault location.

$$k_0 = K (\lambda = 0) = \frac{Z_s^1}{Z_{DG}^1 + Z_{L2}^1 (1 + \frac{Z_{DG}^1}{Z_{L1}^1})} \quad (19)$$

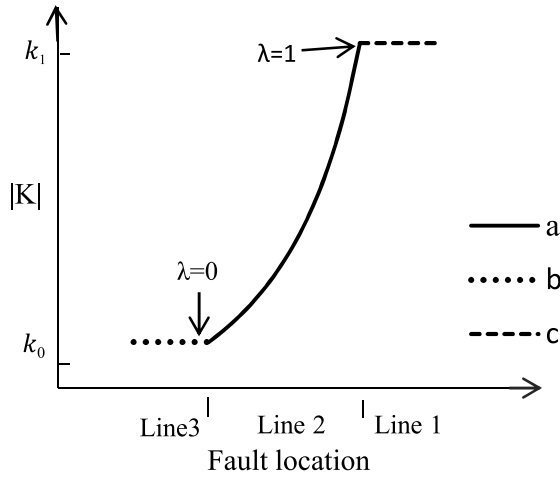
$$k_1 = K (\lambda = 1) = \frac{Z_s^1 + Z_{L2}^1 (1 + \frac{Z_s^1}{Z_{L3}^1})}{Z_{DG}^1} \quad (20)$$

The values of index  $K$  for three short circuits at the downstream and upstream adjacent feeders and the DG-connected feeder are depicted in Fig. 9. By investigating Fig. 9 and Eqs. (12), (15), and (18), the following conclusions are notable. The proposed method is based on these conclusions:

1. If the fault is on the upstream adjacent feeder (Line 3),  $K = k_0$  (Eq. (19)), and its value is independent of fault location.
2. If the fault is on the downstream adjacent feeder (Line 1),  $K = k_1$  (Eq. (20)), and its value is independent of fault location.
3. If the fault is on the DG-connected feeder (Line 2),  $k_0 < K < k_1$ , and its value depends on the fault location ( $\lambda$ ).

The comparison of these three cases can be adopted for the prevention of a sympathetic trip. Fig. 10 shows the proposed method algorithm for sympathetic trip prevention in the presence of DG. The proposed method is adaptively adopted on the distribution network. Regarding the number and size of DGs and the short circuit impedances are measured and  $k_0(DG_i)$  and  $k_1(DG_i)$  are calculated using (21) and (22). In (21) and (22),  $Z_s^1$ ,  $Z_{DGi}^1$ ,  $Z_{L1i}^1$ ,  $Z_{L2i}^1$ , and  $Z_{L3i}^1$  are the positive sequence impedance of downstream network, DG, the feeder which the DG is connected, downstream feeder of DG, upstream, feeder of DG, respectively. With occurring a short circuit, the current increases from the threshold of DGs' over current protection, and the algorithm is started. Accordingly, the positive sequence current of each DG and external grid are measured and  $K(DG_i) = I_{DG_i}^1 / I_s^1$  is calculated. If,  $|k_0(DG_i)| < |K(DG_i)| < |k_1(DG_i)|$ , then the fault has occurred on the DG-connected feeder; otherwise, the fault is on adjacent feeders and the function of DGi protection device or DGi-connected feeder needs to be locked to prevent sympathetic trip. As per Eqs. (12), (15), and (18), index  $K$  is independent of fault type. The proposed method is





**FIGURE 9.** Changes of  $K$  vs fault location (a: Fault on DG feeder, b: Fault on adjacent feeder upstream of the DG, c: Fault on downstream feeder of the DG).

applicable for various types of short circuits. As mentioned, the impedance fault doesn't any affect on the results.

$$k_0(DG_i) = \frac{Z_s^1}{Z_{DG_i}^1 + Z_{L_{2i}}^1 \left(1 + \frac{Z_{DG_i}^1}{Z_{L_{1i}}^1}\right)}, \quad i = 1, 2, \dots, n_{DG} \quad (21)$$

$$k_1(DG_i) = \frac{Z_s^1 + Z_{L_{2i}}^1 \left(1 + \frac{Z_s^1}{Z_{L_{3i}}^1}\right)}{Z_{DG_i}^1}, \quad i = 1, 2, \dots, n_{DG} \quad (22)$$

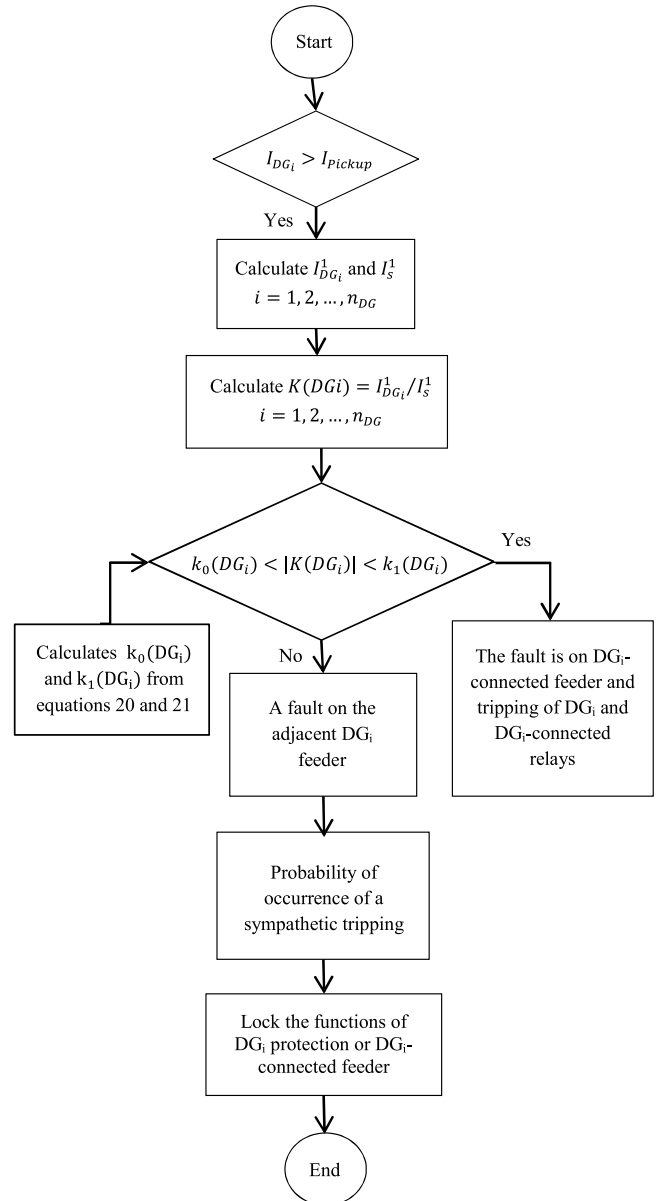
#### IV. SIMULATIONS AND RESULTS ANALYSIS

A 25 kV distribution system is simulated in DIgSILENT to analyze the sympathetic trip in the presence of DGs and to demonstrate the efficiency of the proposed method in preventing this phenomenon (Fig. 11) [27]. The upstream network with a short circuit level of 637 MVA and  $X/R = 8$  is modeled at a 69 kV bus. The main substation contains a 69/25 kV transform with a capacity of 15 MVA and an equivalent series impedance of 7.8%. The distribution system consists of three load feeders, namely,  $LF_1$ ,  $LF_2$ , and  $LF_3$ , with an equal impedance of  $0.2138 + j0.2880 \Omega/km$  and lengths of respectively 20, 10, and 10 km.  $DG_1$  and  $DG_2$  units are modeled as synchronous generators and are connected to the distribution system via connecting transformers  $T_2$  and  $T_3$  with specifications of 0.66/25 kV, 18 MVA, and impedance of 8%. Each of the synchronous generators has a sub-transient reactance of 18.6%, 0.66 kV, and 18 MVA, with a power factor of 0.85.

Specifications of overcurrent relays used in the lines and DG units are as follows [28]:

Overcurrent relay  $LF_1$ : SEL751-1A (51P1, C1 standard inverse), TD = 0.33 sec, Ipu = 1.02 sec.A, and CT 300/1A

Overcurrent relay  $LF_2$ : SEL751-1A (51P1, C1 standard inverse), TD = 0.28 sec, Ipu = 0.5 sec.A, and CT 300/1A



**FIGURE 10.** The proposed method algorithm for solving the sympathetic trip issue.

Overcurrent relay  $LF_3$ : SEL751-1A(51P1, C1 standard inverse), TD = 0.19 sec, Ipu = 0.96 sec.A, and CT 300/1A

Overcurrent relay  $CF_1$ : SEL751-1A(51P1, C2 very inverse), TD = 0.1 sec, Ipu = 4.9 sec.A, and CT 300/5A

Overcurrent relay  $CF_2$ : SEL751-1A(51P1, C2 very inverse), TD = 0.1 sec, Ipu = 5 sec.A, and CT 300/5A

Various types of short circuits are applied at different distances of lines  $LF_1$ ,  $LF_2$ , and  $LF_3$ . Values of index  $K$  for individual DGs are tabulated in Tables 2 and 3. The information provided in these tables are adapted with the theory:

For the  $DG_1$  unit, when a fault occurs on adjacent feeders  $LF_1$ ,  $LF_2$ , and  $LF_3$ , the value of  $K$  for  $DG_1$  is independent of fault location and type of short circuit, according to Eq. (15) and Table 2, and is constant;  $|k_0(DG_1)| = 0.7085$ .

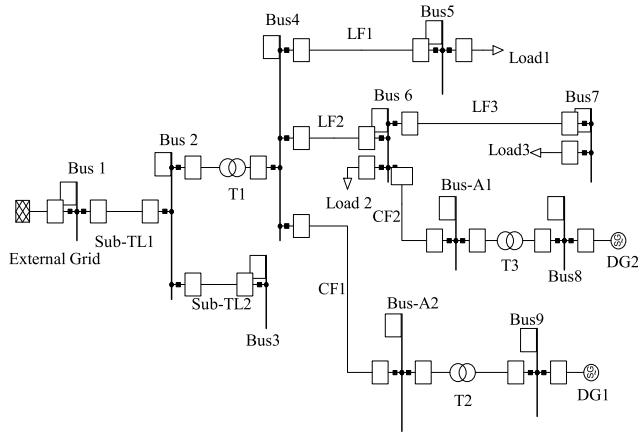


FIGURE 11. Simulated model in DigSILENT to evaluate the efficiency of the suggested method.

For the DG2 unit, when a fault occurs on adjacent feeders LF<sub>1</sub> and LF<sub>3</sub>, the value of  $K$  is constant as per Eqs. (12)-(13) and Table 3, and is independent of the location and type of short circuit. However, when a fault occurs on LF<sub>2</sub> (DG2-connected feeder),  $K$  varies and relies on fault location, where  $0.5450 < |K(DG_2)| < 1.2364$ ,  $|k_0(DG_2)| = 0.5450$ , and  $|k_1(DG_2)| = 1.2364$ .

By applying short circuits to different distances on the lines, the cases resulting in a sympathetic trip along with the values of index  $K$  are listed in Tables 4-6. For instance, based on Table 4, when an LL short circuit occurs on LF<sub>1</sub> at a distance of 40% from Bus 4, overcurrent protection of DG1 acts faster than that of LF<sub>1</sub>, and a sympathetic trip occurs.

To prevent a sympathetic trip in the aforementioned six cases, the proposed algorithm using the coding in DigSILENT software is applied to the network. Positive-sequence currents of DG units and the external network in each of the measurement cases and  $K(DG_i) = I_{DG_i}^1 / I_s^1$  are calculated. For the DG1 unit, in case  $|K(DG_1)| > |k_0(DG_1)| = 0.7085$ , the fault has occurred on the DG-connected feeder; otherwise, the fault is on the adjacent feeder to DG1. To avoid the sympathetic trip, the function of the overcurrent relay for the CF1 feeder is locked for some interval. Additionally, for DG2 unit, in case  $|k_0(DG_2)| = 0.5450 < |K(DG_2)| < |k_1(DG_2)| = 1.2364$  the fault is on the DG-connected feeder; otherwise, the fault is on feeders adjacent to the DG. Again, the function of overcurrent relays for LF2 and CF2 is locked for a specific period to prevent a sympathetic trip.

For instance, Fig. 12 shows three-phase currents for DGs (CF1 and CF2), LF1, and protection device operating time. An LL fault at time  $t = 0.1$  sec is applied to LF1 at a distance of 20% from the common bus. At  $t = 0.840$  sec, the protective relay of the DG1 feeder (CF1) operates, and unnecessary DG1 is disconnected from the network (a sympathetic trip). At  $t = 1.093$  sec, the DG2 feeder protection device (CF2) operates and the unnecessary DG2 is disconnected. Ultimately, at  $t = 1.252$  sec, the protective device of LF1 (the faulty feeder) operates. In this case, a sympathetic trip

TABLE 2. Value of  $K$  for DG1.

$ K(DG_1) = \frac{I_{DG_1}^1}{I_s^1} $		Fault feeder		
		LF1	LF2	LF3
Distance between the fault location and common bus	80	0.7085	0.7085	0.7085
	60	0.7085	0.7085	0.7085
	40	0.7085	0.7085	0.7085
	20	0.7085	0.7085	0.7085

TABLE 3. Value of  $K$  for DG 2.

$ K(DG_2) = \frac{I_{DG_2}^1}{I_s^1} $		Fault feeder		
		LF1	LF2	LF3
Distance between the fault location and common bus	80	0.5450	1.0659	1.2364
	60	0.5450	0.9135	1.2364
	40	0.5450	0.7770	1.2364
	20	0.5450	0.6546	1.2364

TABLE 4. Sympathetic tripping due to a fault on LF1.

Fault type	Distance from Bus 4 (%)	Fault on LF1				
		$t_{R(LF1)}$	$t_{R(CF1)}$	$t_{R(CF2)}$	$K(DG1)$	$K(DG2)$
LL	40	1.345	1.124	-	0.7085	0.5450
	20	1.252	0.840	1.093	0.7085	0.5450
LLG	20	1.121	0.950	-	0.7085	0.5450

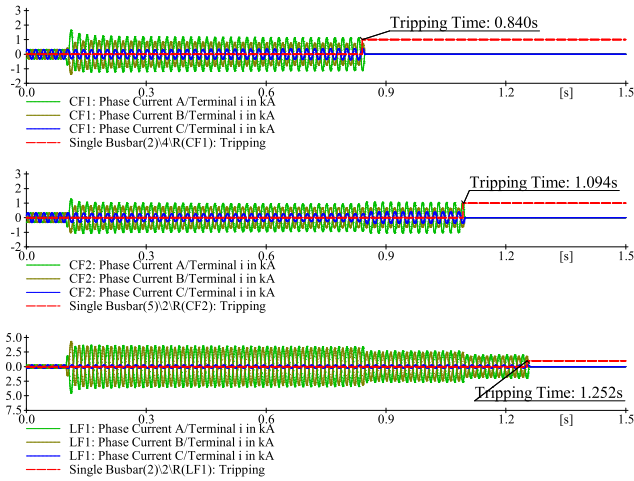
TABLE 5. Sympathetic tripping due to a fault on LF2.

Fault type	Distance from Bus 4 (%)	Fault on LF2				
		$t_{R(LF2)}$	$t_{R(CF1)}$	$t_{R(CF2)}$	$K(DG1)$	$K(DG2)$
LL	40	0.843	0.786	0.719	0.7085	0.7770
	20	0.823	0.692	0.754	0.7085	0.6546

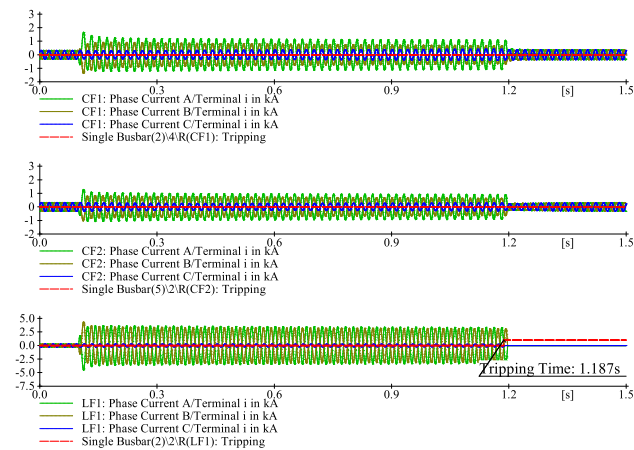
has occurred. To avoid such an event, the proposed method is applied to a test network. In this case, for DG1, we have  $|K(DG1)| = |k_0(DG1)| = 0.7085$ , as per Table 2; hence, the fault is detected on DG1 adjacent feeder and the function of the DG1 feeder overcurrent protection is locked. Moreover, for DG2, we have  $|K(DG2)| = |k_0(DG2)| = 0.5450$ ; so,

**TABLE 6.** Sympathetic tripping due to a fault on LF3.

Fault type	Distance from Bus 6 (%)	Fault on LF3				
		$t_{R(LF3)}$	$t_{R(CF1)}$	$t_{R(CF2)}$	$K(DG1)$	$K(DG2)$
LL	20	0.744	-	0.698	0.7085	1.2364

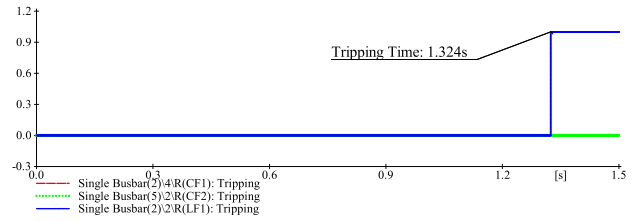


**FIGURE 12.** Sympathetic tripping when an LL fault occurs at 20% distance on feeder LF1.

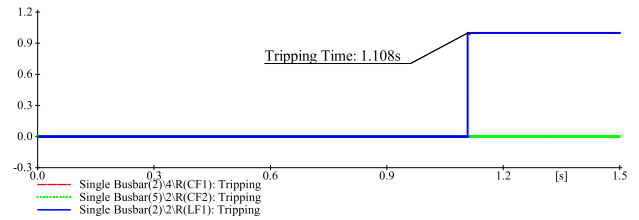


**FIGURE 13.** Preventing sympathetic tripping when an LL fault occurs at 20% distance on feeder LF1.

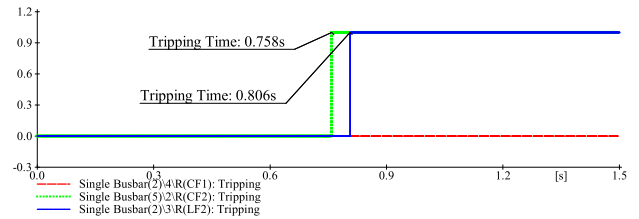
the fault is identified on DG2 adjacent feeder and the protective operation of DG2 overcurrent relay is locked. Fig. 13 illustrates the current and protective operating times of DG1, DG2, and LF1. With a fault occurrence on LF1 and locking the operation of overcurrent relays of CF1, CF2, and LF2, DG1 and DG2 units are still present in the distribution system. Finally, at  $t = 1.108$  sec, the protective relay of the LF1 feeder operates and the faulty feeder is disconnected from the rest of the network.



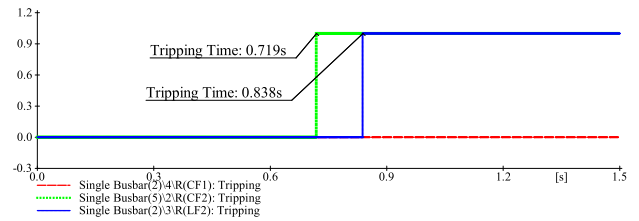
**FIGURE 14.** Tripping time of the overcurrent protections when an LL fault occurs at 40% distance on feeder LF1.



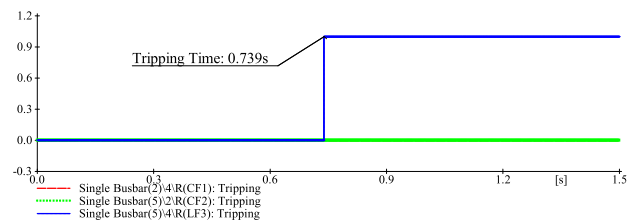
**FIGURE 15.** Tripping time of the overcurrent protection when an LLG fault occurs at 20% distance on feeder LF1.



**FIGURE 16.** Tripping time of the overcurrent protection when an LL fault occurs at 20% distance on feeder LF2.



**FIGURE 17.** Tripping time of the overcurrent protection when an LL fault occurs at 40% distance on feeder LF2.



**FIGURE 18.** Tripping time of the overcurrent protection when an LL fault occurs at 20% distance on feeder LF3.

Figs. 14-18 show the protection operating time of DG1, DG2, and faulty feeder in the other five cases when the proposed method is applied to prevent sympathetic trip. In all cases, the unnecessary disconnection of DG units and DG-connected feeders is avoided. The suggested method

shows satisfactory performance for various short circuits and the presence of any number of DGs and perfectly avoids sympathetic trips.

The methods introduced in [13]–[15] require a smart protection network for the prevention of sympathetic trips, and protection settings vary when the network configuration changes. Reference [11] proposes a method that needs many protective devices in addition to requiring a smart protection network. These methods are costly. The method presented in [16] can be applied to only LL faults and has no use for other types of short circuits. Nonetheless, the method described in this paper can be incorporated for various fault types and does not rely on telecommunication platforms or additional protective equipment. In fact, the method is comprehensive and less costly.

## V. CONCLUSION

The paper presents current equations for DG, external network, and fault location upon a short circuit so that the effect of different parameters of the network on short circuit currents is investigated. Moreover, the method adopts novel sympathetic trip prevention in the presence of DGs, which can be applied to various types of faults and DG-rich networks. The proposed methodology works based on measuring positive-sequence currents of DG units and the external network. Index  $K$  that represents the ratio between the positive-sequence currents of DG and external fault, is calculated for each DG by measuring positive-sequence currents. Fault location is identified according to the value of  $K$ . In case the fault is detected on DG adjacent feeder, the function of the protective device of DG or its related feeder is locked to prevent sympathetic trip. The proposed method is applied to a test network, and the obtained results demonstrate its efficient performance, where the method prevents sympathetic trips in all cases. By doing this, incorrect disconnection of DG units or their feeders is avoided; thus, the number of interrupted customers, the amount of energy not-supplied, the number of common interruptions, etc. are reduced and power quality indices are improved.

## REFERENCES

- [1] H. Bronzeado and R. Yacamini, "Phenomenon of sympathetic interaction between transformers caused by inrush transients," *IEE Proc. Sci., Meas. Technol.*, vol. 142, no. 4, pp. 323–329, Jul. 1995.
- [2] A. R. Haron, A. Mohamed, H. Shareef, and H. Zayandehroodi, "Analysis and solutions of overcurrent protection issues in a microgrid," in *Proc. IEEE Int. Conf. Power Energy (PECon)*, Dec. 2012, pp. 644–649.
- [3] B. O. Agili, M. M. Abdu AL-Ziz, and H. K. Yossif, "Prevention of sympathetic tripping phenomena on power system by fault level management," in *Proc. IEEE/PES Transmiss. Distrib. Conf. Exposit.*, Apr. 2008, pp. 1–14.
- [4] H. Sabra, D. K. Ibrahim, and M. Gilany, "Field experience with sympathetic tripping in distribution networks: Problems and solutions," *J. Eng.*, vol. 2018, no. 15, pp. 1181–1185, Oct. 2018.
- [5] H. V. Padullaparti, P. Chirapongsananurak, M. E. Hernandez, and S. Santoso, "Analytical approach to estimate feeder accommodation limits based on protection criteria," *IEEE Access*, vol. 4, pp. 4066–4081, 2016.
- [6] V. A. Papaspiliotopoulos, V. A. Kleftakis, P. C. Kotsampopoulos, G. N. Korres, and N. D. Hatziaargyriou, "Hardware-in-the-loop simulation for protection blinding and sympathetic tripping in distribution grids with high penetration of distributed generation," in *Proc. MedPower*, Athens, Greece, Nov. 2014.
- [7] Y. Baghzouz, "Some general rules for distributed generation-feeder interaction," in *Proc. IEEE Power Eng. Soc. Gen. Meeting*, Jun. 2006, p. 4.
- [8] S. Boljevic and M. F. Conlon, "The contribution to distribution network short-circuit current level from the connection of distributed generation," in *Proc. 43rd Int. Universities Power Eng. Conf. (UPEC)*, Sep. 2008, pp. 1–6.
- [9] M. E. Baran, H. Hooshyar, Z. Shen, and A. Huang, "Accommodating high PV penetration on distribution feeders," *IEEE Trans. Smart Grid*, vol. 3, no. 2, pp. 1039–1046, Jun. 2012.
- [10] H. Cheung, A. Hamlyn, L. Wang, C. Yang, and R. Cheung, "Investigations of impacts of distributed generations on feeder protections," in *Proc. IEEE Power Energy Soc. Gen. Meeting*, Jul. 2009, pp. 1–7.
- [11] O. V. G. Swathika and S. Hemamalini, "Prims-aided Dijkstra algorithm for adaptive protection in microgrids," *IEEE J. Emerg. Sel. Topics Power Electron.*, vol. 4, no. 4, pp. 1279–1286, Dec. 2016.
- [12] R. J. N. de Alencar, A. M. D. Ferreira, L. G. Martins, and W. R. S. Furtado, "A new methodology to prevent sympathetic tripping in distributed generation protection using discrete wavelet transform," in *Proc. IEEE PES Innov. Smart Grid Technol. Conf. Latin Amer. (ISGT Latin Amer.)*, Sep. 2019, pp. 1–6.
- [13] A. Sharma and B. K. Panigrahi, "Interphase fault relaying scheme to mitigate sympathetic tripping in meshed distribution system," *IEEE Trans. Ind. Appl.*, vol. 55, no. 1, pp. 850–857, Jan. 2019.
- [14] V. A. Papaspiliotopoulos, G. N. Korres, V. A. Kleftakis, and N. D. Hatziaargyriou, "Hardware-in-the-loop design and optimal setting of adaptive protection schemes for distribution systems with distributed generation," *IEEE Trans. Power Del.*, vol. 32, no. 1, pp. 393–400, Feb. 2015.
- [15] F. Coffele, C. Booth, and A. Dysko, "An adaptive overcurrent protection scheme for distribution networks," *IEEE Trans. Power Del.*, vol. 30, no. 2, pp. 561–568, Apr. 2015.
- [16] T. D. Le and M. Petit, "Directional relays for distribution networks with distributed generation," in *Proc. 11th IET Int. Conf. Develop. Power Syst. Protection (DPSP)*, Apr. 2012, pp. 1–6.
- [17] D. S. Kumar, D. Srinivasan, and T. Reindl, "A fast and scalable protection scheme for distribution networks with distributed generation," *IEEE Trans. Power Del.*, vol. 31, no. 1, pp. 67–75, Feb. 2016.
- [18] G. L. N. Rocha and Y. Lopes, "Analysis of sympathetic tripping problem in photovoltaic distributed generation with IEC 61850," in *Proc. Simposio Brasileiro de Sistemas Eletricos (SBSE)*, May 2018, pp. 1–6.
- [19] A. N. Stefamidi, I. A. Panos, A. N. Milioudis, and G. T. Andreou, "Sympathetic tripping in a field case study," in *Proc. 53rd Int. Universities Power Eng. Conf. (UPEC)*, Sep. 2018, pp. 1–5.
- [20] F. Aminifar, S. Teimourzadeh, A. Shahsavari, M. Savaghebi, and M. S. Golsorkhi, "Machine learning for protection of distribution networks and power electronics-interfaced systems," *Electr. J.*, vol. 34, no. 1, Jan. 2021, Art. no. 106886.
- [21] R. Bekhradian, M. Davarpanah, and M. Sanaye-Pasand, "Current-based blocking scheme to stabilize distribution network relays against FIDVR," *Int. J. Electr. Power Energy Syst.*, vol. 132, Nov. 2021, Art. no. 107205.
- [22] R. C. S. P. Tambun, K. M. Banjar-Nahor, N. Hariyanto, F. S. Rahman, and R. Rahmani, "Adaptive protection coordination scheme for distribution system under penetration of distributed generation," in *Proc. 3rd Int. Conf. High Voltage Eng. Power Syst. (ICHVEPS)*, Oct. 2021, pp. 355–360.
- [23] K. Jennett, F. Coffele, and C. Booth, "Comprehensive and quantitative analysis of protection problems associated with increasing penetration of inverter-interfaced DG," in *Proc. 11th IET Int. Conf. Develop. Power Syst. Protection (DPSP)*, Apr. 2012, p. 31.
- [24] A. M. Massoud, S. Ahmed, S. J. Finney, and B. W. Williams, "Inverter-based versus synchronous-based distributed generation; fault current limitation and protection issues," in *Proc. IEEE Energy Convers. Congr. Expo.*, Sep. 2010, pp. 58–63.
- [25] J. L. Blackburn, "Basic fundamentals and the sequence networks," in *Symmetrical Components for Power Systems Engineering*. New York, NY, USA: CRC Press, 2017, ch. 4, pp. 39–84.
- [26] J. C. Das, "Unsymmetrical fault calculations," in *Understanding Symmetrical Components for Power System Modeling*. New York, NY, USA: Marcel Dekker, 2017, ch. 6, sec. 6, pp. 116–126. [Online], Available: <https://www.wiley.com/enus/Understanding+Symmetrical+Components+for+Power+System+Modeling-p-9781119226857>
- [27] B. Hussain, S. M. Sharkh, and S. Hussain, "Impact studies of distributed generation on power quality and protection setup of an existing distribution network," in *Proc. SPEEDAM*, Jun. 2010, pp. 1243–1246.

- [28] A. M. Sleva, "Protective relay functions," in *Protective Relay Principles*. London, U.K.: CRC Press, 2018, ch. 5, pp. 80–85.



**TAHEREH DEGHANI FIROUZABADI** was born in Maybod, Yazd, Iran, in 1991. She received the B.S. degree in electrical engineering from the Isfahan University of Technology, Isfahan, Iran, in 2016. She is currently pursuing the degree in power system engineering with Yazd University, Yazd. Her research interests include distribution networks, power quality, and optimization in power systems.



**MOHAMMADREZA MAZID** received the B.Sc. and M.Sc. degrees from the Iran University of Science and Technology, Tehran, Iran, in 2010 and 2012, respectively, and the Ph.D. degree in electrical engineering from the University of Tehran, Tehran, in 2016. His research interests include operation and control microgrids and stability and control of power systems.



**HADI SAFDARKHANI** received the B.S., M.S., and Ph.D. degrees in electrical engineering from the Amirkabir University of Technology, Tehran, Iran, in 2005, 2008, and 2015, respectively. He is currently an Assistant Professor with the Department of Electrical Engineering, Yazd University, Yazd, Iran. His research interest includes analog and digital system analysis and design.



**DAVOUD ABOOTORABI ZARCHI** was born in Yazd, Iran, in 1984. He received the B.S. degree in electrical engineering from the Amirkabir University of Technology, Tehran, Iran, in 2007, the M.S. degree in electrical engineering from the Sharif University of Technology, Tehran, in 2010, and the Ph.D. degree in electrical engineering from the Amirkabir University of Technology, in 2016. He is currently an Assistant Professor of power systems with the Department of Electrical Engineering, Yazd University, Yazd. His research interests include high-voltage distribution systems and optimization applications in power systems.



**HAMED NAFISI** received the B.Sc., M.Sc., and Ph.D. degrees in electrical engineering from the Iranian Center of Excellence in Power Systems, Amirkabir University of Technology, Tehran, Iran, in 2006, 2008, and 2014, respectively. He is currently a Research Fellow with the School of Electrical and Electronic Engineering, Technological University Dublin (TU Dublin). His current research interests include smart grids, peer-to-peer energy trading, electric vehicles, power system protection, and power electronics applications in power systems.

...