

AEGIS Experiment Commissioning at CERN

D. Krasnický^{a,b}, S. Aghion^{c,d}, C. Amsler^e, A. Ariga^e, T. Ariga^e,
 A. S. Belov^f, G. Bonomi^{g,h}, P. Bräunigⁱ, R. S. Brusa^j, J. Bremer^k,
 G. Burghart^k, L. Cabaret^l, M. Caccia^d, C. Canali^m, R. Caravita^{n,d},
 F. Castelliⁿ, G. Cerchiarini^{n,d}, S. Cialdiⁿ, D. Comparat^l, G. Consolati^{o,d},
 L. Dassa^g, S. Di Domizio^b, L. Di Noto^j, M. Doser^k, A. Dudarev^k,
 A. Ereditato^e, R. Ferragut^{c,d}, A. Fontana^h, P. Genova^h, M. Giammarchi^d,
 A. Gligorova^p, S. N. Gninenko^f, S. D. Hogan^q, S. Haider^k, E. Jordan^r,
 L. V. Jørgensen^k, T. Kaltenbacher^k, J. Kawada^e, A. Kellerbauer^r,
 M. Kimura^e, V. Lagomarsino^a, S. Mariazzi^j, V. A. Matveev^{f,s}, F. Merkt^t,
 F. Moia^{c,d}, G. Nebbia^u, P. Nédélec^v, M. K. Oberthalerⁱ, N. Pacifico^p,
 V. Petráček^w, C. Pistillo^e, F. Prelz^d, M. Prevedelli^x, C. Regenfus^m,
 C. Riccardi^{y,h}, O. Røhne^z, A. Rotondi^{y,h}, H. Sandaker^p, P. Scampoli^e,
 J. Storey^e, M.A. Subieta Vasquez^{g,h}, M. Špaček^w, G. Testera^b,
 R. Vaccarone^b, F. Villaⁿ and S. Zavatarelli^b

^aUniversity of Genoa, Dept of Physics, Via Dodecaneso 33, 16146 Genoa, Italy

^bIstituto Nazionale di Fisica Nucleare, Sez. di Genova, Via Dodecaneso 33, 16146 Genoa, Italy

^cPolitecnico di Milano, LNESS and Dept of Physics, Via Anzani 42, 22100 Como, Italy

^dIstituto Nazionale di Fisica Nucleare, Sez. di Milano, Via Celoria 16, 20133 Milano, Italy

^eAlbert Einstein Center for Fundamental Physics, University of Bern, 3012 Bern, Switzerland

^fInstitute for Nuclear Research of the Russian Academy of Sciences, Moscow 117312, Russia

^gUniversity of Brescia, Dept of Mech. and Indust. Engineering, Via Branze 38, 25133 Brescia, Italy

^hIstituto Nazionale di Fisica Nucleare, Sez. di Pavia, Via Agostino Bassi 6, 27100 Pavia, Italy

ⁱUniversity of Heidelberg, Kirchoff Institute for Physics, Im Neuenheimer Feld 227,
69120 Heidelberg, Germany

^jDipartimento di Fisica, Università di Trento and INFN, Gruppo collegato di Trento, Via
Sommarive 14, 38050 Povo, Trento, Italy

^kEuropean Organisation for Nuclear Research, Physics Department, 1211 Genève 23, Switzerland

^lLaboratoire Aimé Cotton, CNRS, Université Paris Sud, ENS Cachan, Bâtiment 505, Campus
d'Orsay, 91405 Orsay Cedex, France

^mUniversity of Zurich, Physics Institute, Winterthurerstrasse 190, 8057 Zürich, Switzerland

ⁿUniversity of Milano, Dept of Physics, Via Celoria 16, 20133 Milano, Italy

^oPolitecnico di Milano, Dept of Aerospace Sci. and Tech., Via La Masa 34, 20156 Milano, Italy

^pUniversity of Bergen, Institute of Physics and Technology, Alleegaten 55, 5007 Bergen, Norway

^qUniversity College London, Dept of Physics and Astronomy, Gower Street, London WC1E 6BT, UK

^rMax Planck Institute for Nuclear Physics, Saupfercheckweg 1, 69117 Heidelberg, Germany

^sJoint Institute for Nuclear Research, 141980 Dubna, Russia

^tETH Zurich, Laboratory for Physical Chemistry, 8093 Zürich, Switzerland

^uIstituto Nazionale di Fisica Nucleare, Sez. di Padova, Via Marzolo 8, 35131 Padova, Italy

^vClaude Bernard University Lyon 1, Institut de Physique Nucléaire de Lyon, 4 Rue Enrico Fermi,
69622 Villeurbanne, France

^wCzech Technical University in Prague, FNSPE, Břehová 7, 11519 Praha 1, Czech Republic

^xUniversity of Bologna, Dept of Physics, Via Irnerio 46, 40126 Bologna, Italy

^yUniversity of Pavia, Dept of Nuclear and Theoretical Physics, Via Bassi 6, 27100 Pavia, Italy

^zUniversity of Oslo, Dept of Physics, Sem Sælands vei 24, 0371 Oslo, Norway

Non-Neutral Plasma Physics VIII

AIP Conf. Proc. 1521, 144-153 (2013); doi: 10.1063/1.4796070

© 2013 American Institute of Physics 978-0-7354-1144-9/\$30.00

Abstract. The AEGIS Experiment is an international collaboration based at CERN whose aim is to perform the first direct measurement of the gravitational acceleration g of antihydrogen in the gravitational field of the Earth. Cold antihydrogen will be produced with a pulsed charge exchange reaction in a cylindrical Penning trap where antiprotons will be cooled to 100 mK. The cold antihydrogen will be produced in an excited Rydberg state and subsequently formed into a beam. The deflection of the antihydrogen beam will be measured by using Moiré deflectometer gratings. After being approved in late 2008, AEGIS started taking data in a commissioning phase early 2012. This report presents an overview of the AEGIS experiment, describes its current status and shows the first measurements on antiproton catching and cooling in the 5 T Penning catching trap. We will also present details on the techniques needed for the 100 mK antihydrogen production, such as pulsed positronium production and its excitation with lasers.

Keywords: Antimatter, Positronium, Antihydrogen, Penning trap, Gravity, AEGIS

PACS: 04.80.-y, 07.77.Gx, 36.10.-k, 36.10.Dr, 36.10.Gv

INTRODUCTION

Since the 1980s, when low energy antiprotons became available at CERN, the low energy antimatter research community strived to perform high precision measurements on antihydrogen ($\bar{\text{H}}$). Low energy antihydrogen – produced for the first time in 2002 [1, 2] – opens the possibilities to perform precise tests of CPT invariance and tests of the Weak Equivalence Principle (WEP) with antimatter. Previous gravitational experiments to test the WEP with charged antimatter, such as antiprotons [3], were overwhelmed by systematic errors due to the strength of electromagnetic forces on a bare charge. Thus interest has been oriented towards recombination of positrons and antiprotons in order to create antihydrogen for spectroscopic measurements to test the CPT invariance and to perform a gravity measurement on electrically neutral antimatter, which significantly reduces the effect of stray and in general inhomogeneous electromagnetic fields.

The Antimatter Experiment: Gravity, Interferometry and Spectroscopy (AEGIS) [4] encompasses many of the main challenges of low energy antimatter research. The primary and currently pursued goal is a 1% measurement of the gravitational acceleration g of antihydrogen in the gravitational field of the Earth [5, 6, 7]. This would be the first direct measurement of the WEP on antimatter. The experiment is based at the CERN laboratory in the Antiproton Decelerator (AD) hall – the only place in the world with low energy (5.3 MeV) antiprotons. The gravity measurement in AEGIS will be performed by forming a pulsed cold antihydrogen beam and observing its vertical deflection in a set of Moiré deflectometer gratings.

AEGIS EXPERIMENTAL SCHEME

In AEGIS a novel antihydrogen production scheme was chosen. Whereas the standard techniques of $\bar{\text{H}}$ production are continuous, in AEGIS the production method will be pulsed and repeated every few cycles of the AD machine. The method is based on a charge exchange reaction between highly excited positronium (Ps) and cold antiprotons:



The reaction in Eq. (1) has some particular advantages:

- The cross section scales as $\sigma \propto n_{\text{Ps}}^4$, where n_{Ps} is the positronium principal quantum number. For $n_{\text{Ps}} \sim 25$, $\sigma \simeq 10^{-9} \text{ cm}^2$.
- The principal quantum number of antihydrogen ($n_{\bar{\text{H}}}$) is determined by n_{Ps} (which can be controlled to some extent with lasers).
- The resulting antihydrogen temperature is given by the temperature of antiprotons prior to formation.

Charge exchange reaction for $\bar{\text{H}}$ production was first proposed by B.I. Deutch et al. [8]. It was demonstrated with excited Cs atom beam by ATRAP experiment [9]. In AEGIS the production of $\bar{\text{H}}$ differs from the forementioned method as the $\bar{\text{H}}$ atoms will be produced in one pulse using a different positronium production mechanism.

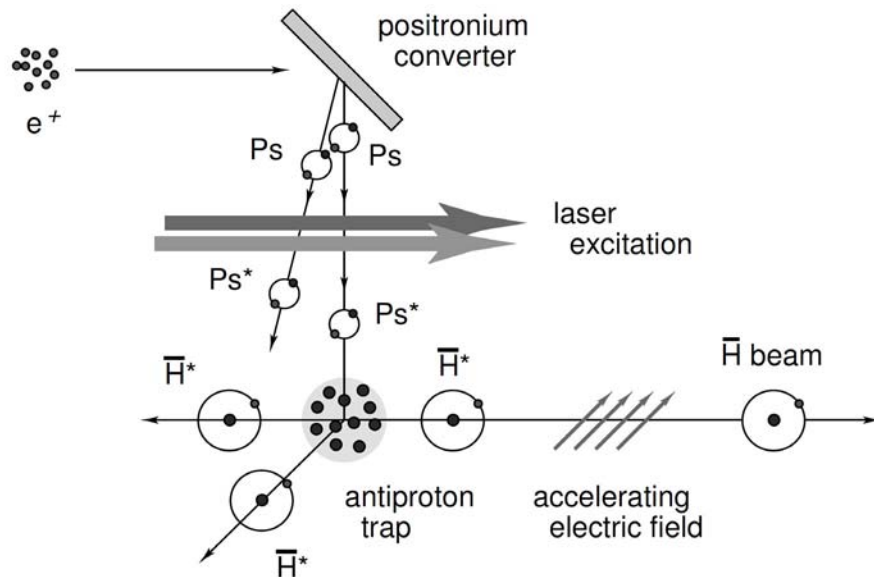

FIGURE 1. Schematic of pulsed antihydrogen production in AEGIS. With permission from [6].

The scheme of production of antihydrogen in AEGIS is shown in Fig. 1. Positronium will be produced in a nanoporous silica target after an implantation of a bunch consisting of $\sim 10^8$ positrons. The longer lived ortho-positronium (o-Ps) diffuses out of the target material and is excited by lasers into Rydberg levels. Rydberg positronium then enters through a semi-transparent Penning-trap electrode structure, interacts with a pre-cooled 100 mK antiproton cloud and forms cold Rydberg antihydrogen. The antihydrogen does not remain confined in the Penning trap and it will thus slowly spread out isotropically with its thermal velocity distribution ($v \approx 25 - 80 \text{ m/s}$). To form the $\bar{\text{H}}$ beam we will use the strong electric dipole moment of Rydberg atoms which makes them very sensitive to inhomogeneous electric fields. By forming an electric field gradient we will accelerate neutral antimatter. This manipulation technique (Stark acceleration) has been demon-

strated by members of the AEGIS collaboration, where Rydberg hydrogen atoms with $v = 720$ m/s were stopped in $4.7 \mu\text{s}$ within 1.9 mm flight-path [10].

In AEGIS we will form a cold antihydrogen beam by applying time-varying electric potentials to segments of trap electrodes immediately after $\bar{\text{H}}$ production. In this way we expect to create a beam of antihydrogen with a broad distribution of axial velocities ranging from 300 m/s to 600 m/s, with a transverse velocity slightly lower than the original thermal distribution [11].

Positronium production and excitation

As shown in the schematic in Fig. 2 the production of positronium comprises a number of operations in Penning-Malmberg traps located in a 1 T superconducting magnet. The system consists of two parallel traps, where the central (on-axis) trap is devoted to the storage and cooling of antiprotons and the second trap (located off the main axis) is dedicated to positron acceleration towards the Ps conversion target.

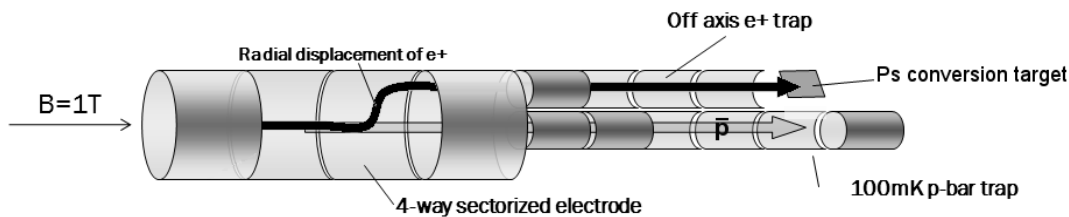

FIGURE 2. Schematic of the 1 T antihydrogen production trap system in AEGIS. The positron cloud is loaded into a high voltage off-axis trap using an autoresonance technique whereas antiprotons are transferred along the axis to the ultracold trap.

At first a cloud of $\sim 10^8$ positrons produced in a Surko-type positron accumulator [12] is brought to a larger radius Penning-Malmberg trap located on the main axis. Here positrons need to be loaded into the off-axis high voltage trap before they can be accelerated towards the Ps conversion target. Moving positrons off-axis is done by an autoresonant excitation of the $m = 1$ diocotron mode of the positron plasma. This technique has been demonstrated and well described by Danielson et al. [14] with electrons in high magnetic fields. For the purposes of AEGIS an additional set of measurements was performed with the emphasis on reproducibility and eventual losses of this technique in fields as low as 0.25 T. The measurements have shown a high level of control of the radial and angular position of an electron cloud and indicated minimal losses or radial expansion [15].

The off-axis high voltage trap serves to accelerate positrons towards the positronium conversion target. The target is nanochanneled Si p-type in which the diameter of the oxidized nanochannels can be tuned within 5-100 nm during the fabrication process. Such material shows very high ortho-positronium yield (Fig. 3) when implanted with positrons. The o-Ps fraction reaching the vacuum through the nanochannels is up to 42% at 1 keV and still 10% at 10 keV positron implantation energy [16]. This target is

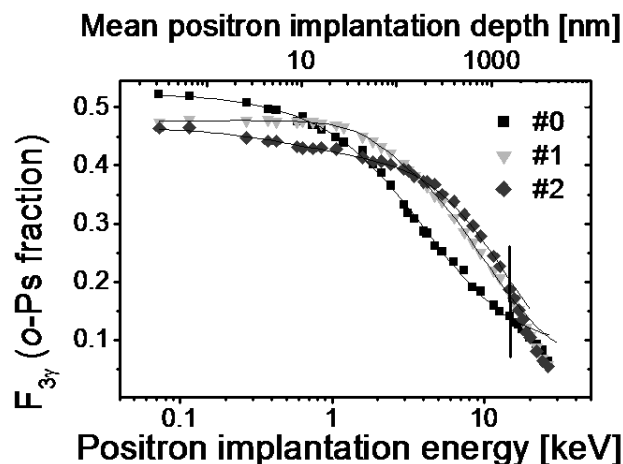

FIGURE 3. Fraction of implanted positrons annihilating via 3 gamma as ortho-positronium. Modified from [16]. Curves #0, #1 and #2 correspond to nanochannel diameter of 4-7 nm, 8-12 nm and 8-14 nm respectively.

currently being installed in the AEGIS apparatus. Hydrophobic positronium converters suitable for AEGIS based on silica (aerogel and MCM-41) are also under study within the collaboration [17, 18].

To obtain a high charge exchange reaction rate, the positronium needs to be excited to high energy levels. This will be achieved by two superimposed laser pulses perpendicular to the trap axis, which will excite positronium as it leaves the target surface. The AEGIS laser system consists of a UV pulse with $\lambda = 205$ nm which induces the $n_{\text{Ps}} = 1 \rightarrow n_{\text{Ps}} = 3$ transition and a tunable IR laser pulse with $\lambda = 1650$ -1700 nm which allows for $n_{\text{Ps}} = 3 \rightarrow n_{\text{Ps}} = 16 - 30$ transitions [19]. The efficiency of this two stage positronium excitation through the $n = 3$ transition should be $\sim 30\%$.

Gravity measurement

The gravitational acceleration g of antihydrogen will be measured by studying the fringe pattern created by a Moiré deflectometer [20] – a classical counterpart to the Mach-Zehnder atom interferometer. It is a device composed of three equidistant gratings, where the first two gratings create a shadow (Moiré) pattern of particles that is detected by looking at the transmission of the third grating. Members of the AEGIS collaboration have measured the local gravitational acceleration using a Moiré deflectometer with a beam of Argon atoms and reached a relative precision $\delta g/g = 2 \times 10^{-4}$ [20]. The main advantage of Moiré deflectometer is that neither a collimated nor ultracold nor monochromatic beam is necessary to perform a measurement with such precision. If L is the length between the gratings and v is the velocity of the beam, the vertical shift due

to gravity is:

$$\delta x = -g \frac{L^2}{v^2} . \quad (2)$$

In AEgIS the third grating will be replaced by a high resolution position sensitive detector (Fig. 4), which will work in vacuum and under cryogenic conditions. The flux of antihydrogen will be low, so that with a reasonably fast detector individual $\bar{\text{H}}$ annihilations on the detector could be detected. By measuring the vertical shifts δx and the times of flight (and thus the velocities) of incoming antihydrogen atoms one can fit the data using Eq. 2 and determine the local gravitational acceleration of antihydrogen g .

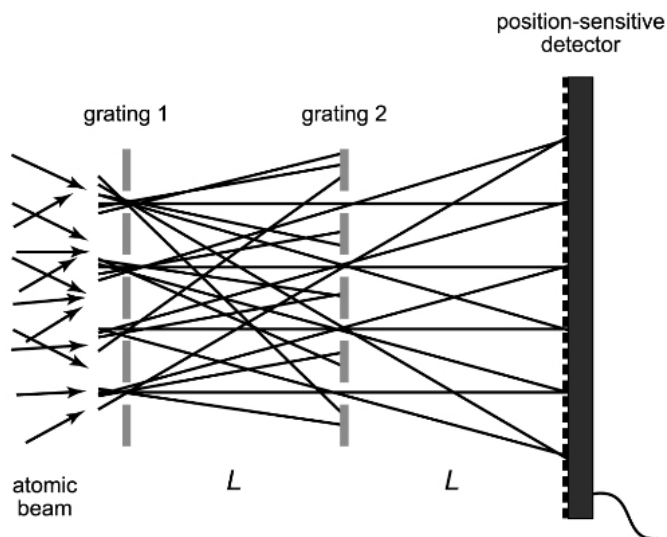

FIGURE 4. Schematic of the Moiré deflectometer in AEgIS with position sensitive detector instead of the third grating. With permission from [6].

AEGIS EXPERIMENTAL APPARATUS

Figure 5 shows the AEgIS experimental apparatus once fully completed. Antiprotons ($\sim 3.1 \times 10^7$ per bunch) coming from the AD at 5.3 MeV energy are slowed down in a set of thin aluminum foils (so-called degrader foils) with variable thicknesses located at the entrance of the 5 T magnet. Antiprotons are caught using the standard technique of quickly raising the high voltage of the entrance electrode of the trap after the passage of the antiproton bunch. In this way only a small fraction of initial antiprotons is caught. These antiprotons are subsequently cooled down by a previously loaded cloud of electrons (which in turn cools by emission of cyclotron radiation in the 5 T magnetic field). Cold antiprotons with energies in the sub-eV range will then be transferred toward the 1 T magnet where the final cooling and $\bar{\text{H}}$ production will take place as mentioned earlier.

The positron accumulator [12] (First Point Scientific) along with the positron transfer line are located above the AD beam line allowing for positron injection into the main apparatus from the same side as antiprotons.

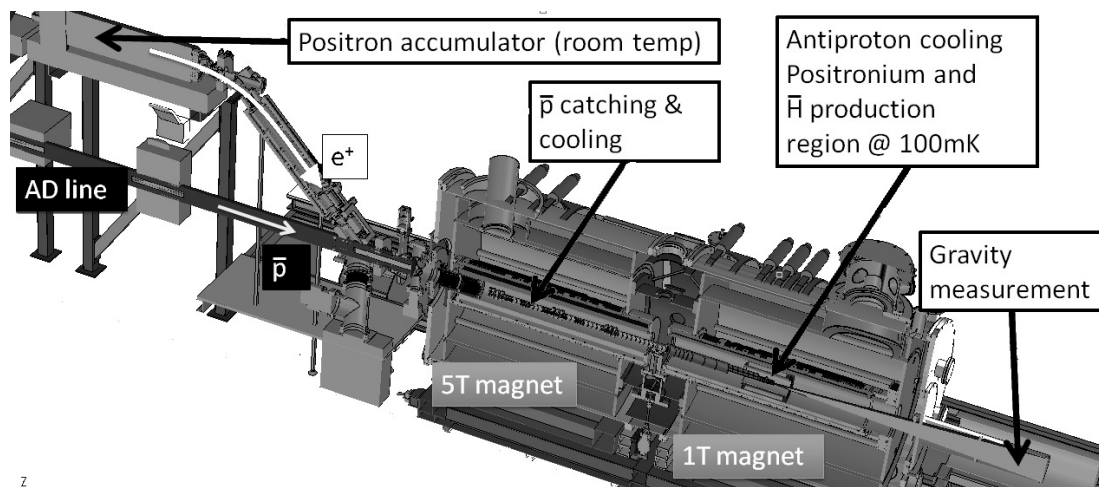

FIGURE 5. A 3D cut-open view of the full AEGIS apparatus at the CERN Antiproton Decelerator. During the first commissioning run the 1T magnet, the Moiré deflectometer and the positron transfer line were not present.

COMMISSIONING OF 5 T CATCHING TRAP

During the first commissioning run of AEGIS (May-June 2012) the 5 T magnet and the \bar{p} catching trap system were tested. An additional chamber at the end of the 5 T cryostat was mounted to study direct low energy antiproton annihilations on various detectors.

The 5 T Penning-Malmberg catching trap has been designed for antiproton and positron catching, cooling and subsequent transfer into the 1 T magnet. It consists of a 1 m-long stack of cylindrical electrodes of 30 mm inner diameter with three high voltage electrodes that divide two multi-ring trap harmonic regions. The whole trap with its support is inside a vacuum chamber of the 5 T superconducting magnet. The trap stack reaches a temperature of $\simeq 11$ K. Three high voltage electrodes were chosen in order to add variability to the antiproton catching length, in this way two \bar{p} trapping lengths of 46 cm or 76 cm are available. The first high voltage electrode, which is located at the beginning of the trap stack right after a movable degrader foil, is connected to fast switching electronics.

Antiproton catching

Roughly half of the incoming antiprotons annihilate on the degrader foils, the rest enter the trap with a broad energy spectrum. Antiprotons with energies below the trapping high voltage pass the first high voltage electrode (momentarily at ground) and are reflected by the second (static) HV electrode. Before the \bar{p} bunch exits the trap stack we switch on the first HV electrode and trap it.

Antiprotons are detected using a set of plastic scintillators coupled to magnetically shielded photomultiplier tubes which were positioned around the 5 T cryostat vessel. The detection efficiency for single antiproton annihilation has been calculated using

GEANT3 MC with real AEGIS geometry and – depending on the scintillator size – is in the range of 6 – 11%.

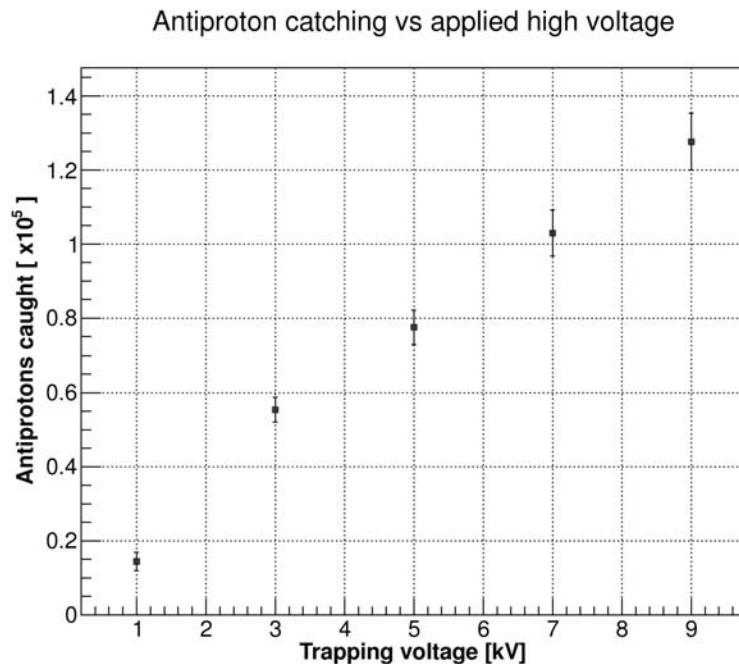

FIGURE 6. Number of antiprotons caught vs. trapping voltage for 3.1×10^7 incident antiprotons. Antiprotons were confined for 5 s in a 46 cm-long high voltage trap before being released towards the degrader foil.

Figure 6 shows the number of trapped antiprotons with respect to the trapping high voltage. Antiprotons were stored for 5 s before the high voltage on the first electrode was gradually switched off and \bar{p} were allowed to annihilate on the degrader foil (the so-called “hot dump”). A roughly linear increase of \bar{p} caught with high voltage is observed. The regular operating conditions in AEGIS were at 9 kV, where $\sim 1.3 \times 10^5$ antiprotons were caught per AD bunch ($\sim 3.1 \times 10^7 \bar{p}$). This means almost a 10-fold increase in trapping efficiency ($\sim 0.4\%$) when compared to the ATHENA experiment ($\sim 0.05\%$) [13].

Trapping runs with storage times up to 300 s were also performed and no significant losses of antiprotons were observed in both 46 cm or 76 cm-long trap configuration.

Electron cooling

Electron cooling of antiprotons was performed by loading a cloud of $10^7 - 10^8$ electrons into a ~ 120 V deep potential well prior to the antiproton bunch arrival. Once trapped, the antiprotons collided with electrons and lost energy until they remained confined in the 120 V deep well along with the electrons. After the hot dump (lowering of HV potentials from 9 kV \rightarrow 0) the so-called “cold dump” was performed in which the cold antiprotons were released towards the degrader foil. Measuring the ratios of the hot

to cold antiprotons for various cooling/storage times indicates that in our experimental conditions $\sim 90\%$ of antiprotons were cooled to eV-range within 20 s.

Detector tests

During the catching and cooling runs described in the previous section a pixelated silicon sensor and emulsion films were tested in order to assess the position resolution of such detectors with on-detector antiproton annihilation. Such measurements took place in a symbiotic way: the antiprotons not caught by the trapping system passed through a $2\ \mu\text{m}$ thick titanium vacuum separation foil at the exit of the 5 T magnet into the detector test chamber, where either a Mimotera Si pixel detector or nuclear emulsion films were directly exposed to low energy ($\leq 500\ \text{keV}$) antiprotons.

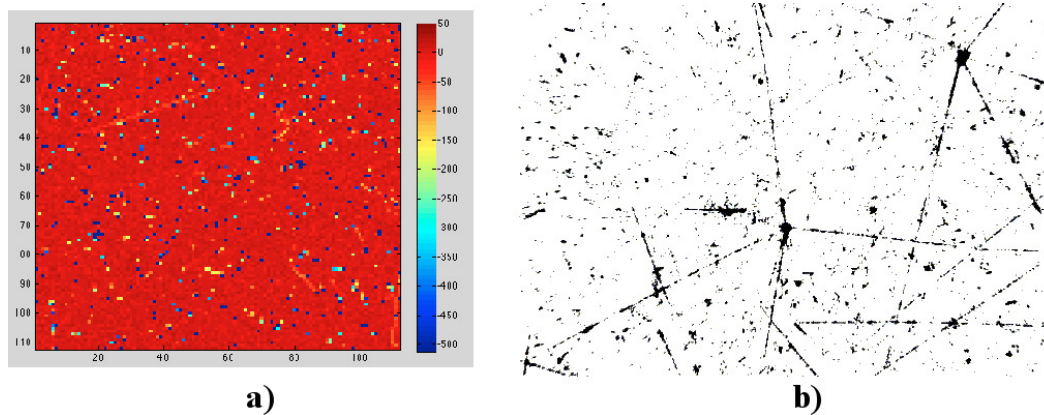

FIGURE 7. Low energy antiprotons annihilating on the detector surface. a) Mimotera pixel detector showing antiproton annihilation spots (dark blue), sporadic pion tracks are also visible (rare cases when pion was travelling along the detector's active volume). b) A developed and scanned nuclear emulsion after in-vacuum direct exposure to low energy antiprotons.

The Mimotera detector [21] has a very thin active layer ($15\ \mu\text{m}$) and a very high dynamic range, making it appropriate to detect events with a high energy release like the antiproton annihilation. With the Mimotera we were able to detect clear antiproton annihilation spots (Fig. 7). The nuclear emulsion test was novel [22] as it was performed in vacuum and showed that the emulsion technology would allow for position resolution of $\leq 2\ \mu\text{m}$, which is 5 times higher than the one envisaged in the AEGIS proposal [5]. Two snapshots of measurements with these detectors are shown in Fig. 7. Novel high precision detection techniques could reduce the required data-taking time by a factor of 4 with respect to the original AEGIS proposal.

CURRENT STATUS AND SHORT TERM PLANS

Currently (autumn 2012) AEGIS is undergoing its second assembly phase. The positron accumulator chain and the e^+ transfer line are completed and under commissioning. The 1 T magnet is ready and being installed in the experimental zone along with the

1 T traps and \bar{H} production detector based on a scintillating fiber technology. A hybrid position sensitive detector for the gravity measurement is under development along with the 100 mK dilution refrigerator which will be ready for installation in 2014.

Since the accelerator complex at CERN will be shut down during 2013 AEGIS collaborators have developed a proton source, so that in 2013 pulsed hydrogen production using the charge exchange reaction can be tested. In this case we will take advantage of the fact that the reaction given in Eq. 1 is symmetric and allows to produce Rydberg hydrogen if protons are cooled by positrons ($Ps^* + p \rightarrow H^* + e^+$).

CONCLUSIONS

AEGIS is a challenging multidisciplinary physics experiment with the aim of performing the first measurement of matter – antimatter gravitational interaction. This year, in the first run with antiprotons, we have successfully tested the new antiproton beam line, the 5 T superconducting magnet and the long antiproton catching trap. We have also performed tests with low energy antiprotons for precise \bar{p} annihilation detector necessary for the gravity measurement. The experiment started taking data in a commissioning phase and is on track to perform first gravity measurements in the near future.

REFERENCES

1. M. Amoretti et al. (ATHENA collaboration), *Nature* **419**, 456 (2002)
2. G. Gabrielse et al. (ATRAP collaboration), *Phys. Rev. Lett.* **89**, 213401 (2002)
3. M.H. Holzscheiter et al., *Nucl. Phys. A* **558**, 709c (1993)
4. <http://cern.ch/aegis>
5. M. Amoretti et al. (AEGIS collaboration), *Proposal for the AEGIS Experiment at the CERN Antiproton Decelerator*, CERN-SPSC-2007-017, <http://cdsweb.cern.ch/record/1037532>
6. A. Kellerbauer et al. (AEGIS collaboration), *Nucl. Instrum. Methods B* **266**, 351-356 (2008)
7. M. Doser et al. (AEGIS collaboration), *Class. Quantum Grav.* **29**, 184009 (2012)
8. B.I. Deutch et al., *Proceedings of the 1st Workshop on Antimatter Physics at Low Energies* (1986), p.371, <http://ss.fnal.gov/conf/C860410/>
9. C.H. Storry et al. (ATRAP collaboration), *Phys. Rev. Lett.* **93**, 263401 (2004)
10. E. Vliegen and F. Merkt, *Phys. Rev. Lett.* **97**, 033002 (2006)
11. G. Testera et al., *AIP Conf. Proc.* **1037**, 5 (2008)
12. R. G. Greaves et al., *Phys. Plasmas* **1**, 1439 (1994)
13. M. Amoretti et al. (ATHENA collaboration), *Nucl. Instrum. Methods A* **518**, 679-711 (2004)
14. J.R. Danielson et al., *Phys. Plasmas* **13**, 123502 (2006)
15. C. Canali et al., *Eur. Phys. J. D* **65** (3), 499-504 (2011)
16. S. Mariazzi et al., *Phys. Rev. B* **81**, 235418 (2010)
17. R. Ferragut et al., *Can. J. Phys.* **89**, 17-24 (2011)
18. G. Consolati et al., *Mesoporous materials for antihydrogen production*, *Chem. Soc. Rev.* in press, doi: 10.1039/c2cs35454c (2013)
19. S. Cialdi et al., *Nucl. Instrum. Methods B* **269**, 1527-1533 (2011)
20. M. Oberthaler, et al., *Phys. Rev. A* **54**, 3165 (1996)
21. L. Badano et al., *Proceedings of DIPAC 2007*, <http://accelconf.web.cern.ch/accelconf/d07/papers/wepc20.pdf>
22. C. Amsler et al., *A new application of emulsions to measure the gravity force on antihydrogen*, submitted to *Journal of Instrumentation*