



## **Economic Analysis of Heat Distribution Concepts for a Small Solar District Heating System**

Downloaded from: <https://research.chalmers.se>, 2022-11-19 13:26 UTC

Citation for the original published paper (version of record):

Andersen, M., Bales, C., Dalenbäck, J. (2022). Economic Analysis of Heat Distribution Concepts for a Small Solar District Heating System. *Energies*, 15(13). <http://dx.doi.org/10.3390/en15134737>

N.B. When citing this work, cite the original published paper.

## Article

# Economic Analysis of Heat Distribution Concepts for a Small Solar District Heating System

Martin Andersen <sup>1,2,\*</sup> , Chris Bales <sup>1</sup> and Jan-Olof Dalenbäck <sup>2</sup>

<sup>1</sup> Solar Energy Research Center (SERC), Dalarna University (Högskolan Dalarna), 78170 Borlänge, Sweden; cba@du.se

<sup>2</sup> Department of Architecture and Civil Engineering, Chalmers University of Technology, 41296 Gothenburg, Sweden; jan-olof.dalenback@chalmers.se

\* Correspondence: maar@du.se

**Abstract:** One challenge in today's district heating systems is the relatively high distribution heat loss. Lowering distribution temperatures is one way to reduce operational costs resulting from high heat losses, while changing the distribution system from steel pipes to plastic pipes and changing the heat distribution concept can reduce investment costs. The result is that the overall life cycle cost of the district heating system is reduced, leading to the improved cost competitiveness of district heating versus individual heating options. The main aim of this study was to determine the most cost-efficient distribution system for a theoretical solar district heating system, by comparing the marginal life cycle cost of two different distribution systems. A secondary aim was to determine the influence of the employed pipe type and insulation level on the marginal life cycle cost by comparing detailed economic calculations, including differences in pipe installation costs and construction costs, among others. A small solar-assisted district heating system has been modeled in TRNSYS based on a real system, and this "hybrid" model is used as a basis for a second model where a novel distribution system is employed and the heating network operating temperature is changed. Results indicate that a novel distribution concept with lower network temperatures and central domestic hot water preparation is most efficient both from an energy and cost perspective. The total life cycle costs vary less than 2% for a given distribution concept when using different pipe types and insulation classes, indicating that the investment costs are more significant than operational costs in reducing life cycle costs. The largest difference in life cycle cost is observed by changing the distribution concept, the novel concept having approximately 24% lower marginal life cycle cost than the "hybrid" system.

**Keywords:** 4GDH; solar thermal; district heat; hot water circulation; GRUDIS; TRNSYS



**Citation:** Andersen, M.; Bales, C.; Dalenbäck, J.-O. Economic Analysis of Heat Distribution Concepts for a Small Solar District Heating System. *Energies* **2022**, *15*, 4737. <https://doi.org/10.3390/en15134737>

Academic Editors: Ahmad Arabkoohsar and Meisam Sadi

Received: 30 May 2022

Accepted: 20 June 2022

Published: 28 June 2022

**Publisher's Note:** MDPI stays neutral with regard to jurisdictional claims in published maps and institutional affiliations.



**Copyright:** © 2022 by the authors. Licensee MDPI, Basel, Switzerland. This article is an open access article distributed under the terms and conditions of the Creative Commons Attribution (CC BY) license (<https://creativecommons.org/licenses/by/4.0/>).

## 1. Introduction

This section sets the premise for the work presented in this article by treating the background of the topic and placing the paper in context by reviewing previous literature. The aims and scope are also outlined, together with a graphical presentation of the overall method used to answer the research questions.

### 1.1. Background

District heating (DH) was invented to recycle energy that would otherwise go to waste. With the onset of the industrial revolution and the employment of heat energy derived from coal, the first generation of DH networks naturally utilised high-temperature steam as a medium for heat transport. However, these networks led to high distribution heat losses and low system efficiency, a deficit of the distribution technology that endured until the third generation of DH that we have today. Presently, operating temperatures are significantly lower than in the past, allowing for a host of new industrial and renewable heat sources alike, while the pipe insulation has improved to reduce heat losses. Although

the fourth generation of DH technology is still being studied by research in the field, the foreseen improvements include even lower operating temperatures, enabling a wide variety of waste-heat sources and a larger share of renewables [1].

Space heating (SH) and domestic hot water (DHW) are two low-temperature application areas often supplied by DH systems in the EU, particularly in the urban areas. The residential sector is responsible for about 50% of the final energy demand in the EU, out of which the vast majority is SH and DHW demand, which is supplied mainly by fossil fuels. The DH share of the EU28 heating demand was about 12% in 2015, out of which only a very small (<1%) share was supplied by solar [2]. The temperature requirements of SH and DHW preparation correspond well to the operating temperature range of solar thermal (ST) energy, and most (>90%) of the installed ST systems are used in small and medium-sized hot water systems in the residential and public sector. However, by the end of 2019, less than 3% of all ST collectors in Europe were installed in large-scale systems (e.g., for DH) [3]. Although as much as 22% of total energy use for heating and cooling in the EU28 was supplied by renewable energy by the end of 2019 [4], only a small (~2%) part of the thermal energy demand in European buildings was covered by ST [5].

Solar thermal (ST) energy has been used in several DH systems with success, the earliest examples of which were realised in the 1980s. In recent years, SDH has matured into a viable alternative for DH companies around Europe. Denmark is today the market leader, closely followed by Germany, Sweden and Austria. The economic feasibility of SDH in these countries has largely been determined by energy policy so that ST energy has achieved parity or even surpassed fossil fuel alternatives in terms of cost per unit of heat [3]. However, the economic viability of DH has always been subject to line heat density, favouring urban areas and limiting its use in rural and suburban environments. Paradoxically, with the development of low-energy housing and political aims to reduce residential sector carbon footprints [6], the heat density of present and future residential areas is set to reduce significantly, which increases the fraction of distribution heat losses and reduces the DH system efficiency. This reduces the economic competitiveness of DH in comparison to other heating methods, and due to this, research efforts are necessary to identify the most efficient distribution options available for low-energy housing areas [1]. Despite previous efforts to identify essential improvements in the future district energy system [7], case studies on implementation are still needed for proof of concept [8].

Today's solar-assisted district heating (SDH) plants typically employ low-temperature flat-plate solar collectors with gas or biomass-fired boilers to achieve a solar-fraction (SF) of 20–50% in the annual heat supply. Solar fractions in the upper half of this range are typically achieved by employing centralised seasonal storage, whereas the values in the lower half are usually achieved by using centralised or decentralised diurnal storage [9,10]. The use of decentralised short-term storage may allow for more strategic use of the heating network and increase the efficiency of the DH system by enabling the use of ST energy locally and reducing distribution heat losses associated with circulation flows needed to uphold the target network operating temperatures. This may be particularly true in so-called hybrid networks, where 3rd and 4th generation DH technology is combined using both high-temperature steel pipes and low-temperature plastic pipes. Operational experiences from these types of systems as well as preliminary economic evaluations show that these networks have advantages over conventional 3rd generation DH networks, although it has been indicated that there may be economic advantages to the use of pure low-temperature plastic networks for heat distribution when compared to the hybrid networks [11,12]. This is the premise of this study.

## 1.2. Previous Work

Early research into distribution networks for suburban housing areas indicated that plastic pipes could be a cost-efficient way to extend networks of higher heat demand densities. Studies in Sweden particularly focused on how to increase the economics of sparse district heating and concluded that plastic pipes were well suited to increase

profitability in areas with low heat density, especially if used in a secondary network working as an extension to a conventional primary network [13]. This conclusion was re-iterated recently when it was stated that cross-linked polyethylene (PEX) pipes encased in evacuated polystyrene (EPS) (abbreviated EPSPEX culvert) have the lowest operating costs for distribution systems in areas of low heat demand density [14]. Another study linked the EPSPEX culvert to best practice in low-temperature district heating (LTDH) [10], while a recent study stated the use of PEX culverts as an essential improvement in 4th generation DH systems [7].

Until the present, the pipe type traditionally employed in DH networks has been made from steel and, although modern pipes employ polyurethane (PUR) foam for insulation, the developments in distribution technology have been limited to increasing the insulation level. One of the precursors for this may be the re-emergence of PEX pipes for distribution systems after their use was largely discontinued in the 80s [13]. However, it has been indicated that the cost difference of these pipes compared to their steel counterparts has been reduced [15], which may have limited their employment. In recent technical developments, a new pipe type has emerged for low-temperature applications. The pipe is employed for LTDH, using a PUR insulated polyethylene (PE) pipe with some of the best features of steel and PEX pipes combined [16]. Nonetheless, as the use of this pipe is part of an ongoing research project, the research results are still not known, but the intention is to provide the industry with a new solution for future DH systems.

However, as much as new technology can be a solution to an old problem, old technology used in new ways can be a solution too. The GRUDIS (Swedish for GRUppcentralDistri-butionsSystem) distribution concept from the 1980s was developed as a solution for sparse DH networks, where conventional steel pipes would prove too expensive. As such, it is an old solution to the relatively new problem of low heat density in urban environments. Due to its characteristics, it may be considered a 4th generation DH technology and should be suitable for low-temperature district heating (LTDH), according to desired characteristics specified in [7,17]. The main characteristics are plastic (PEX) pipes and domestic hot water circulation (DHWC) with direct draw off DHW volume from the pipe without hydraulic separation by heat exchanger (HEX). The advantages of this concept are much the same as for the previously mentioned PE-pipe, in that it features simple installation without welding, which leads to faster and less costly installation.

A previous report [13] has recommended GRUDIS for use mainly in secondary networks, hydraulically separated from conventional (steel-pipe) primary networks with higher working temperatures and pressures. A case study has previously been made on such a system, which is the basis for the study presented here. The initial performance and inner workings of this system were studied in detail in [18], and the performance was later verified in [19]. Subsequent studies have focused on potential energetic improvements in the use of the concept by moving towards a pure LTDH system and removing the high-temperature (HT) primary network altogether [20]. Detailed continuations of these studies have solidified in increasing detail that, although an LTDH system approach has similar energetic performance as a combined network, it could be the economically preferred solution [11,12]. The premise of both these studies includes focusing on the GRUDIS concept and the employment of PEX pipes. The advantages presented for GRUDIS, therefore, automatically include the use of plastic pipe distribution.

Although numerous studies exist on the detailed performance of steel DH pipes and optimal properties of these, few known studies treat detailed economical calculations on the use of PEX pipes versus steel pipes. According to one report [13], several research reports were made in the 1990s on this topic, although only one of these has been found [21]. This study states that the costs for material, installation and groundwork, are lower for PEX pipes than for steel and that, due to diminishing cost savings for large pipe dimensions, these are better suited for low heat-density areas. One report published a decade later makes a simple comparison of EPSPEX versus steel pipes. However, this is based solely on the difference in catalogue values for specific pipe heat loss for “equivalent” pipe dimensions

and an assumed cost for the heat energy loss. The EPSPEX culvert has a 20% lower annual cost than twin steel pipes, although more detailed calculations are recommended [22]. The employed installation costs are also stated to be “rough” estimates, which reduces the generality of the results.

The essence of these few studies was that there is a cost-benefit when using plastic pipe systems in terms of lower heat losses and installation costs. However, despite this, the employment of PEX pipes is still rare in modern DH systems. Older studies have shown that the investment costs of the heating system are the driving factor of the system life cycle cost (LCC) [23]. This fact may be well known by industry professionals, so the costs of distribution pipes and associated heat losses may have been neglected. This would explain the low adoption of PEX in the DH sector. Furthermore, presently, with the development of LTDH, the focus of the research has largely focused on operational and technological aspects of the LTDH system and, to a negligible degree, on the distribution network. Surprisingly, studies with a more holistic approach—those that evaluate heating systems and distribution networks together—have not been found. Therefore, studies that holistically highlight the impact of the chosen distribution concept, as well as the most appropriate pipe type, are necessary.

The novelty of this study lies in the presentation of detailed cost calculations both for an existing and novel system solution, comprising a combination of 3rd and 4th generation DH system technology, as well as for a proposed 4th generation system solution for LTDH. Furthermore, the study examines various pipe types suitable for these system solutions and presents detailed costs to quantify the size of these relative to the total system cost. Lastly, the influence of insulation level on the cost competitiveness of the two system solutions is evaluated to clarify the benefits of one over the other. None of this has been found in previous studies, which is why this study is considered a significant contribution to knowledge in the field of solar-assisted district heating.

### *1.3. Aim and Scope*

The main research questions of this paper are: how large are the differences in marginal LCC when using two different distribution concepts for a hypothetical DH system, and how much do the pipe type and insulation level of the employed pipes influence this marginal LCC?

An existing solar DH (SDH) system is used as a basis for a theoretical SDH system, and a simulation model with similar technical specifications is developed. A hybrid system combines a HT steel pipe primary network and a LT PEX pipe secondary network, where the GRUDIS system with DHWC and central DHW preparation in intermediate substations is employed for secondary distribution. An alternative system model employs PEX pipes and GRUDIS distribution throughout the system. Simulations of the two distribution concepts are made using a reference insulation level for both to establish the impact of changing distribution systems on the energy performance of the system. A parametric study is made where the two systems are simulated, varying insulation levels for all distribution pipes and pipe types for PEX pipes, aiming to determine the most techno-economic solution. This is done by providing energetic considerations, followed by calculations of marginal LCC for the two distribution concepts using a reference insulation level and pipe type, as well as for several variants with different pipe types and/or insulation levels, to determine the most economic distribution concept and insulation level. Finally, because the assumed values for the financial boundary conditions have large uncertainty, a sensitivity analysis is made by a variation of financial parameters to determine the potential influence of these on the results from the parametric study.

The study is based on Swedish conditions, concerning both weather and costs. The DH system studied has a low line heat density (LD) as it supplies a load comprised of low-energy houses with a special form of heat distribution. This study does not include conventional DH distribution with pre-insulated steel pipes, higher operating temperatures, and a local heat exchanger for DHW preparation, as this has been covered in a previous

study and, according to cost estimations, was much more costly than the distribution concepts covered in this study. One reason is that the house substation in conventional DH systems is more costly than the one needed in a GRUDIS system, as the GRUDIS system needs no local DHW preparation.

In lack of a commonly adopted terminology to describe hydraulic pipe networks, this paper uses *specific terminology* to differentiate between pipe types. The distribution network consists of “*main*” pipes that are connected in series to supply the (parallel) “*branches*” of the system. Generally, branch pipes supply any load > 1 house, whereas individual houses are supplied by “*service*” pipes. The pipe systems as a whole are termed “*conventional*” when referring to pre-insulated steel pipes, “*GRUDIS*” when referring to plastic pipes, and “*hybrid*” when referring to a combination of the two.

#### 1.4. Overall Method

Figure 1 shows how the work in this study was executed in order of sequence. A case study is made of a solar-assisted DH system, from which two theoretical DH systems are defined using different distribution systems; one hybrid and one GRUDIS. The DH networks were dimensioned by using the technical specifications of the case study to determine the design heat load in the different areas of the DH network, from which flow rates were calculated using hydrodynamic theory. The design heat losses of the pipes were calibrated to design values by simulating the pipe performance under the same specific test conditions listed in manufacturer catalogues. Based on this, models are made in TRNSYS 17 (v.17.02.0005) [24], which includes houses, house substations, intermediate substations, primary and secondary distribution networks, as well as solar collectors and a boiler central (BC). These are denoted variants H1–H8 and G1–G4, where H and G stand for “hybrid” and “GRUDIS”, respectively.

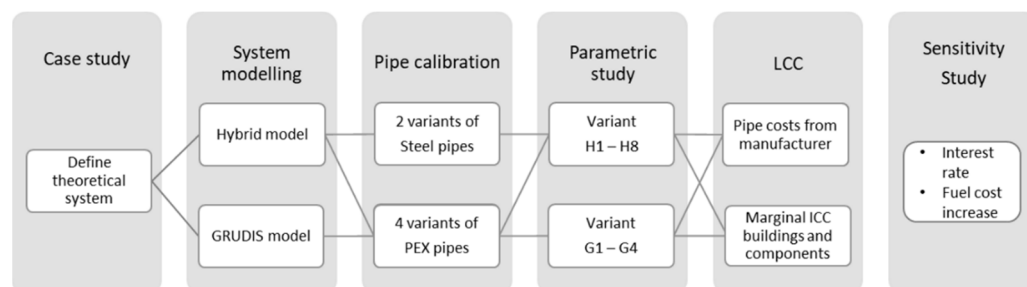

**Figure 1.** Overall process—flowchart showing how the work in this study was executed.

A parametric study is made where the insulation level is varied for the two distribution concepts, either by changing the insulation series and/or the pipe technology/manufacturer, and the energy balance (EB) for all system variants is calculated based on the simulation results. Furthermore, the marginal LCC of all system variants is calculated by including differences in initial capital costs (ICC) of construction due to differences in system configuration, based on cost estimates from entrepreneurial cost calculation software Wikells [25] and cost tenders from pipe manufacturers. Finally, a sensitivity analysis is conducted by changing the interest rate (IR) of the initial capital costs (ICC) for finance and by changing the annual fuel cost increase (FCI) for boiler fuel.

The simulation models have been simplified to make the study more general by scaling common subsystem components such as houses and intermediate substations to give the heat load of the entire subsystem. Furthermore, the distribution network has been modeled by using pipe elements to represent all pipes of the same size and type to give the same heat loss as the design value of the network.

This article is structured such that some content comprises a summary of information from detailed content contained in a data repository to improve readability. Therefore, every section where more details are available will have the data repository cited specifically [26].

## 2. Case Study

Two simulation models have been made in this study, both based on a hypothetical DH system. The systems supply 100 single-family houses, divided into four identical areas (A1–A4) of 25 houses each. This hypothetical system is based on the real system at Vallda Heberg, Sweden [10,18–20,27,28], which has a hybrid distribution system. The two distribution systems configured for the hypothetical DH system are presented in this chapter.

### 2.1. Solar District Heating System Layout

Detailed information on pipe lengths and methods for calculating pipe sizes is available in an Appendix in a data repository related to [26].

Figure 2 [12] shows an overview of (a) the GRUDIS and (b) the hybrid distribution network. Evacuated tube collectors (ETC, red rectangle) are located on the boiler central (BC), which supplies the housing area directly in the GRUDIS system. In contrast, it supplies intermediate substations (SS1–SS4) through a conventional DH primary network in the hybrid system. These intermediate substations, in turn, supply each housing area (note that 1 house represents 5 houses) through a GRUDIS secondary network. Each housing area is named according to the substation it is connected to (only A1 is shown). In Figure 2, this conventional piping is marked in orange and GRUDIS piping in purple. A green solar culvert connects flat plate collectors (FPC, green rectangle) to the BC or intermediate substations. Note that the boiler central is larger in the GRUDIS system (stifled line) due to the absence of intermediate substations.

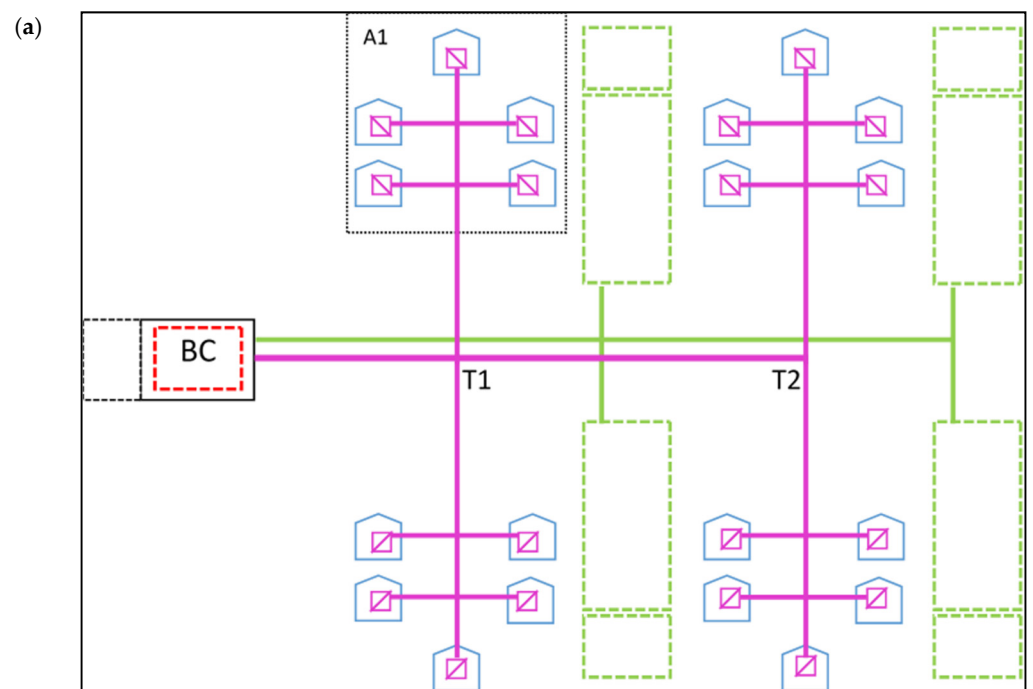
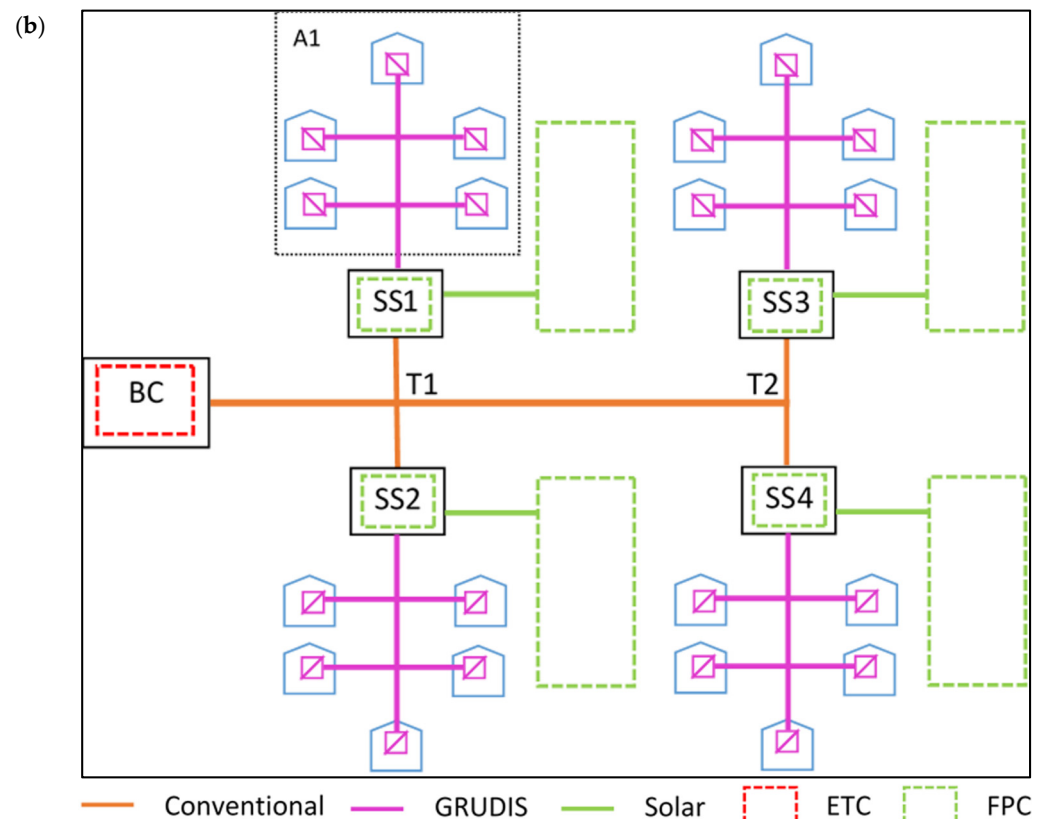

Figure 2. Cont.



**Figure 2.** System layout—schematics of (a) GRUDIS network and (b) hybrid network. Evacuated tube collectors (ETC) are located on the boiler central (BC), and flat plate collectors (FPC) are located on either intermediate substation (SS) and/or ground [12].

## 2.2. Heat Supply

Table 1 shows an overview of the heat supply for the hybrid and GRUDIS distribution system simulated in this study. The DH is supplied with heat by a 300 kW wood-pellet boiler and 108 m<sup>2</sup> evacuated tube collectors (ETC). Both boiler and solar collectors are connected to a 15 m<sup>3</sup> storage in the boiler central (BC). However, the location of flat-plate collector (FPC) arrays and connected storage tanks varies according to the distribution concept.

**Table 1.** Heat supply—Overview of the heat supply configuration for the two distribution concepts investigated in this study. BC = boiler central, SS = Substation, GM = ground-mounted.

Parameters	Hybrid	GRUDIS
Boiler		300 kW
ETC		108 m <sup>2</sup>
(tilt/azimuth)		(70°/0°)
FPC	177 m <sup>2</sup> (SS) + 442 m <sup>2</sup> (GM)	619 m <sup>2</sup> (GM)
(tilt/azimuth)	19°/25° (SS), 30°/20° (GM)	(30°/20°)
Storage tank	15 m <sup>3</sup> (BC) + (15 × 4) m <sup>3</sup> (SS)	15 m <sup>3</sup> (BC) + 60 m <sup>3</sup> (BC)

In the hybrid system—each intermediate substation (see Figure 2) features roughly 155 m<sup>2</sup> of FPC, divided into about 44 m<sup>2</sup> roof-mounted on the substation and about 111 m<sup>2</sup> ground-mounted (GM) in the vicinity of the substation, both arrays connected to a 15 m<sup>3</sup> storage. In the GRUDIS system, roughly 155 m<sup>2</sup> of GM collectors are located in the vicinity of each housing area. These large GM collector arrays can be seen as extensions of the GM arrays in the hybrid system, with the major difference being that heat from these is stored in 60 m<sup>3</sup> of storage tanks located in the boiler central. The storage employed consists of



smaller, off-the-shelf, 5 m<sup>3</sup> accumulator tanks. This means that 15 m<sup>3</sup> storage consists of three storage tanks, while 60 m<sup>3</sup> consists of 12 storage tanks.

### 2.3. Distribution Systems

Two district heating systems supplying the same load type and size have been configured in this study, each using a different distribution concept. The energy system supply is the same for both systems, featuring the same installed solar collector area, solar heat storage volume, and boiler capacity. The distribution network route lengths are also the same, although the pipe type and technology vary. Table 2 shows the configuration of district heating subsystems in the two distribution concepts studied. A reference to the figure showing the subsystem schematic is written below the name of each distribution concept. Note that the design ground temperature is 10 °C.

**Table 2.** Concept overview—summary of the main components of the two distribution concepts studied, along with reference to the figure (s) showing the associated schematic(s). Denotation BC or SS indicates where the collectors are connected to storage.

Component	GRUDIS Figure 2a/Figure 3	Hybrid Figure 2b/Figure 4
Boiler central	Storage for all collectors, DHW preparation	Storage for centralized collectors
Intermediate substation	N/A	Storage for distributed collectors, DHW preparation
House substation	SH only	SH only
Network pipes & design operating temperatures	Primary: PEX 60/50 °C	Primary: Steel 75/50 °C Secondary: PEX 60/50 °C
Collectors	Centralized: ETC (BC) Distributed: FPC (BC)	Centralized: ETC (BC) Distributed: FPC (SS)

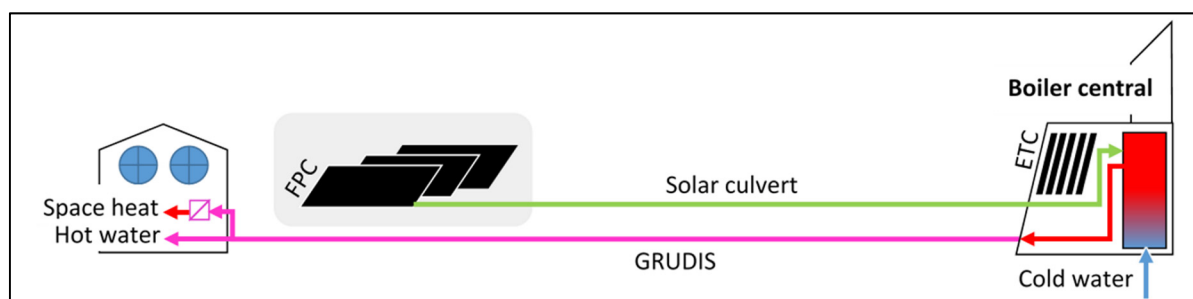

**Figure 3.** GRUDIS distribution—Simple schematic of GRUDIS distribution system with boiler central (BC) and single-family house. Ground-mounted flat-plate collectors (FPC) and evacuated tube collectors (ETC) on the BC [12].

The hybrid system comprises a combination of 3rd- and 4th-generation DH technology, using a novel system design to address the mismatch between the high operating temperatures seen in conventional DH systems and the lower operating temperatures wanted to increase the performance of ST collectors. The GRUDIS system is a suggestion for an alternative system configuration that better matches the optimal temperatures for increased performance of ST collectors and can be viewed as a 4th generation DH technology. The two systems are described more closely with a schematic in Sections 2.3.1 and 2.3.2.

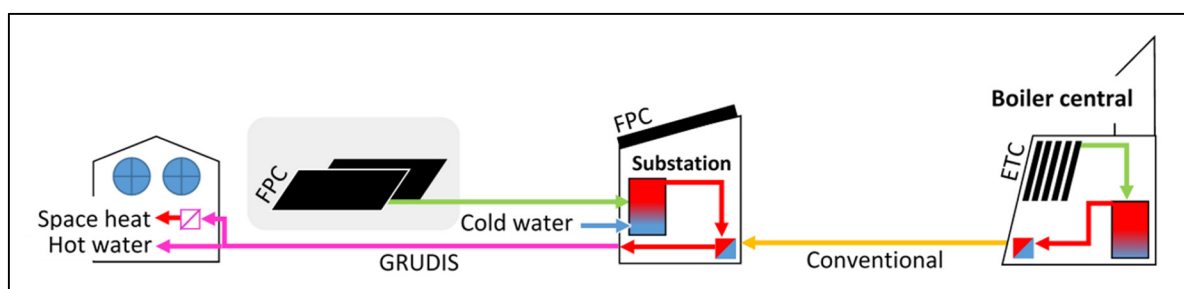

**Figure 4.** Hybrid distribution—Simple schematic of the hybrid heat distribution concept with boiler central (BC), intermediate substation, and single-family house. Roof and ground-mounted flat plate collectors (FPC), evacuated tube collectors (ETC) on boiler central [12].

### 2.3.1. GRUDIS

Figure 3 [12] shows a schematic illustration of the GRUDIS distribution concept, with the boiler central and central DHW preparation. In the GRUDIS concept, hot water is circulated in plastic pipes in a 2-pipe system [13], similar to how it is done in a DHW-circulation loop. Roof-mounted ETCs and ground-mounted FPCs supply a centrally located storage tank, which contains spiral heat exchangers used partially for DHW pre-heating or circulation pre-heating. A wood-pellet boiler supplies additional heat when required to reach the target supply temperature of the buildings. When DHW is tapped in the house substations, it is drawn directly from the circulation loop, and the draw-off volume is immediately replaced by make-up cold water in the boiler central. Space heat is supplied through floor heating in the bathroom of the houses and a ventilation air heat exchanger.

One advantage when using the GRUDIS concept is a fairly simple house substation, which lowers the investment costs. However, a drawback is that solar heat harvested in the distributed collector is stored centrally, which requires locating the solar buffer storage volume to the boiler central. This requires making the boiler central a bit larger, which induces some additional construction costs. Furthermore, the central storage location may lead to additional heat losses when solar heat is transported over a longer distance, which can lower the available solar energy and decrease system performance.

### 2.3.2. Hybrid Distribution Concept

Figure 4 [12] shows a schematic illustration of the hybrid heat distribution concept, with the boiler central to the right, an intermediate substation in the middle, and a passive single-family house to the left. The hybrid distribution system (see Figure 2b) consists of one boiler central and four intermediate substations. In contrast to the GRUDIS system (see Section 2.3.1), the solar buffer storage is located centrally and distributed in the substations. There are FPCs located on the substation roofs and in GM arrays nearby the substations, which supply heat to the substations. The boiler central contains a wood-pellet boiler and building integrated ETCs, which provide the intermediate substations with auxiliary heat to reach the target supply temperature of the building stock through a conventional steel pipe primary network. Heat is supplied to the buildings through a GRUDIS secondary network, which was explained in Section 2.3.1.

As the secondary network in this system employs the GRUDIS concept, one advantage of this configuration is a simple house substation with lower investment costs than in a conventional type of system. However, one disadvantage of the hybrid distribution concept is large heat losses in the distribution pipes and substations, which increases running costs.

#### 2.4. Boundary Conditions and Heat Demand

This section contains some of the boundary conditions relevant to the simulations. More details are found in the data repository [26].

##### 2.4.1. Climate Data and Heat Demand

Climate data for Kungsbacka, Västra Götalands län, Sweden (57.5° N, 12.0° E) were supplied by Meteonorm 7 [29].

Figure 5 [12] shows a graph of cold water inlet supply temperature, monthly average ambient temperature, and global insolation for a typical meteorological year (TMY), together with the simulated monthly mean specific heat demand for a single-family house, in Kungsbacka, Sweden. The annual amount of global horizontal insolation is 984 kWh/m<sup>2</sup>. The simulated annual specific heat demand (SH + DHW) is ~38.5 kWh/m<sup>2</sup>, with values ranging from 5.6 kWh/m<sup>2</sup> (January) to 1.1 kWh/m<sup>2</sup> (July). The simulated total annual heat demand is about 542 MWh. The employed ground temperatures are not shown here but are calculated by the distribution pipe model during simulation. This is done using a sine function based on annual average surface temperature plus an amplitude representing the variation between highest and lowest daily average temperatures during the year, which was taken from the daily ambient temperature profile.

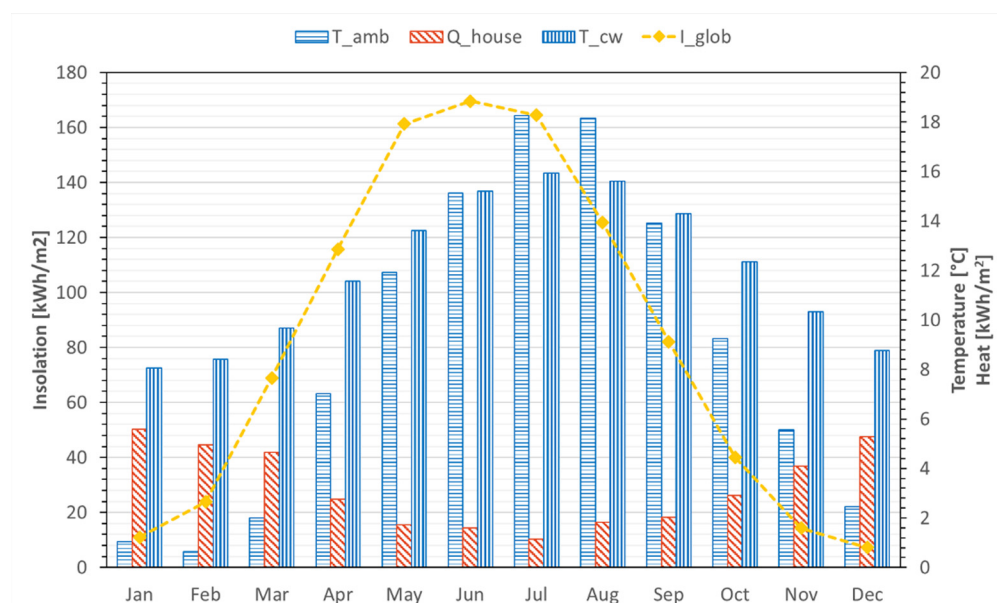

**Figure 5.** Climate data—graph showing monthly global insolation ( $I_{glob}$ ), ambient temperature ( $T_{amb}$ ), cold water inlet supply temperature ( $T_{cw}$ ), along with monthly specific heat demand (SH + DHW) for a single-family house ( $Q_{house}$ ), in Kungsbacka, Sweden [12].

##### 2.4.2. DHW Profiles

The DHW profiles for the district heating system were generated with DHWcalc (v.2.02), using a 3-min random distribution [30]. The draw-off profiles are based on a statistical profile of a multifamily building using 4 tap categories and model the seasonal variations by considering holidays.

Two DHW profiles are used—each one for 50 houses. The cold water inlet supply temperature is modeled using a sinus function for a temperature curve with an annual average of 12 °C and amplitude of 4 °C (January being the coldest—see Figure 5).

### 3. Method

Section 3.1 of this chapter outlines the modeling approach. This has been provided more extensively in a previous study [12], and details of underlying calculations made to model the system can be found in the data repository [26]. Section 3.2 provides an overview

of the parametric study, while Section 3.3 provides the fundamental equations and inputs for calculating life cycle costs. Section 3.4 provides an overview of variables altered in the cost sensitivity analysis. Finally, Section 3.5 explains the employed key performance indicators (KPI) used to analyse the results of simulations and calculations.

### 3.1. Modelling Approach for Deriving Energetic KPIs

Figure 6 [12] shows the simplified model for the hybrid system, including the intermediate substation (SS) model and building model, together with applied pipe sizes. Due to software limitations in TRNSYS on the number of component outputs and the long simulation times related to models exceeding these, both simulation models used in this study are simplified in that they employ scaling of loads. The DH network modeled is symmetric (see Figure 2), so such a simplified approach can be assumed to affect the results insignificantly as this study focused mainly on comparing energy use between system variants.

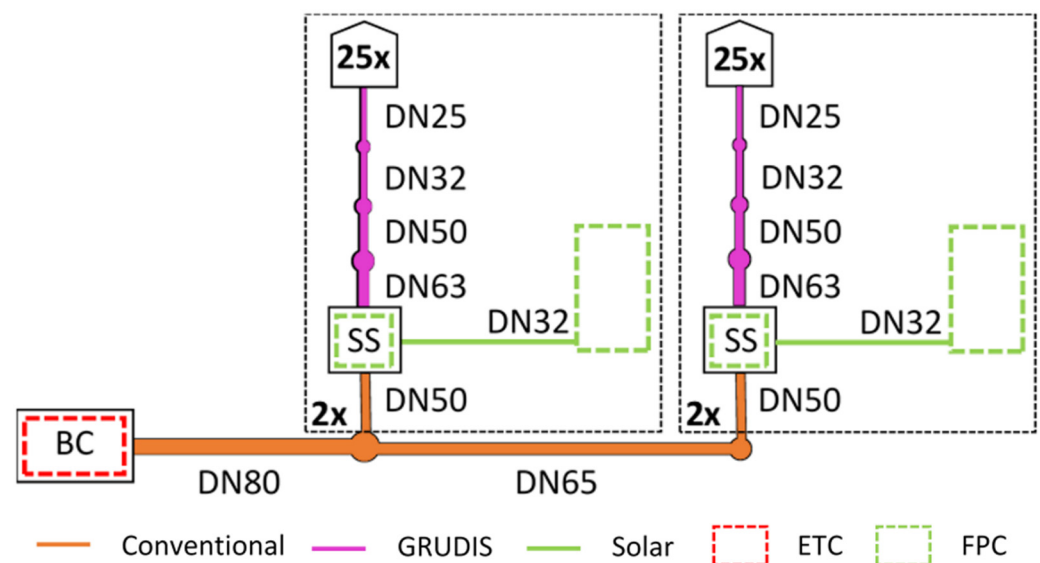

**Figure 6.** Simplified approach—Schematic showing the hybrid system simulation model and applied pipe sizes. Copper pipes in the solar thermal system are not shown. Scaling factors (2x and 25x) are shown in the substation models where these are used [12]. BC = Boiler central. SS = substation.

The hybrid system model can be divided into three subsystem models:

- Building and house substation model (SH load  $\times$  25 = one housing area).
- Intermediate substation model (load  $\times$  2 = subsystem load) and ST system.
- Boiler central model.

The hybrid system was modeled by scaling up the house heating loads by a factor of 25 and connecting this load at the far end of a series of pipe elements that represents the secondary (GRUDIS) network. Each intermediate substation (SS) is scaled up by a factor of 2 to give the total load of the system, as seen from the BC. The simulated load was used to calculate the primary network flow rates by using the simulated supply and return temperatures at the substation, resulting in a realistic load in the primary network.

#### 3.1.1. Common Components for All System Models

Table 3 lists the main TRNSYS components employed and parameter settings.

**Table 3.** Main TRNSYS components and parameter settings [31]. Non-standard components are referenced individually, TESS components are described in [32]. Data from [12].

Name	Component Type	Main Parameters	Descriptions
Weather data	Type 15	Kungsbacka, Sweden (57.5° N, 12.0° E), TMY	Data from Meteonorm 7 (v.7.3.4)
Boiler	Type 659 (TESS) [32]	300 kW	Wood-pellet boiler
ETC	Type 538 (TESS)	108 m <sup>2</sup>	Fluid: water. Tilt 70, azimuth 0
FPC	Type 832v501	620 m <sup>2</sup> ; allocation varies according to concept (see Table 1)	Fluid: 40% propylene glycol/water. Int. substation: Tilt 19, azimuth 25 Ground-mounted array: Tilt 30, azimuth 20
Tank(s)	Type 340 [33]	15 m <sup>3</sup> /60 m <sup>3</sup>	Diurnal storage; volume depends on system
Pump(s)	Type 3	Max flow rate; Varied parameter values	Variable control signal, power consumption, and dissipation to fluid stream ignored.
House	Type 56	Base area 70 m <sup>2</sup> , two zones, internal gains.	Internal gains: 400 W passive + 70% of electricity consumption [27].
Heat recovery	Type 667 (TESS)	Rated power: 186.4 W, Effectiveness: 0.8.	Same effectiveness for both sensible and latent.
Water-air HEX	Type 670 (TESS)	Fluid: Propylene glycol. Effectiveness: 0.8.	Set point 19.5 °C for control of flow to component.
Twin-pipe(s)	Type 951(TESS)	Varied parameters for each pipe size and type.	Distribution network pipe for conventional and GRUDIS
Single pipe(s)	Type 952 (TESS)	Insulation thickness, heat transfer coefficient.	Distribution network pipe for GRUDIS.
Single pipe(s)	Type 709 (TESS)	Varied parameters according to pipe size	Connection pipes for solar collectors and internal supply pipes in BC and intermediate substations.
DHW load(s)	Type 9	Flow rate	Generated DHW profiles, 1 profile per 50 houses.

### 3.1.2. Building and Space-Heating Model

A two-zone building model is used, and its geometry is based on that of a real house. The house model takes into account external gains from sunlight through the windows as well as internal gains from occupants and electricity use. The inputs to the building model are supplied in building information files in the data repository [26].

The house is heated by an air heating circuit, where heat is supplied from the distribution network to a mechanical ventilation system with heat recovery, in addition to year-round passive floor heating.

### 3.1.3. Distribution Pipe Model

Both twin and single pipes use a buried horizontal pipe model, although only the twin pipe includes the thermal resistance of the casing material (HDPE80). For PEX pipes, the EPS insulation and the casing are the same, so no casing resistance is modeled.

The heat losses were calibrated against catalogue data for all pipes to give all of the pipes a common theoretical reference point and allow for a more even comparison between pipes.

### 3.1.4. Reference Pipe Types and Combinations

There are two different pipe types used in the pipe networks in this study, pre-insulated steel pipes and PEX pipes. For steel pipes, one manufacturer is used, whereas, for PEX pipes, two manufacturers are used—both employing a different type of insulation. For the sake of objectivity, manufacturer names are omitted in the content of this article but are mentioned in the acknowledgments section together with references. Generic names have instead been adapted, such as pipe manufacturer 1 (M1), 2 (M2), and 3 (M3). Pipe specifications (pipe dimensions, insulation thermal conductivity, etc.) are found in the data repository [26] for all manufacturers.

For the steel pipes, two insulation classes are used (series 1 and series 2). The dimensions and material parameters used were provided by M1. For PEX pipes, two different technologies are used; EPSPEX and pre-insulated PEX (PI-PEX). The EPSPEX culvert is made by M3, and only the standard insulation class has been used, as additional insulation classes are manufactured only upon request. This culvert comprises a pair of PEX pipes enclosed in a square/rectangular EPS-casing and is available with twin pipes for all pipe sizes used in this study. The PI-PEX pipes used are made by M1 and M2, which both produce pipes in two insulation classes. However, PI-PEX pipes are predominantly available as twin pipes up to pipe size DN63, above which pairs of single pipes must be used.

A reference combination of pipe types and insulation levels has been chosen for the two distribution concepts in order to enable a comparison between various pipe types and combinations in a parametric study (see Section 3.2). The reference pipe type and insulation level for the two distribution concepts are shown in Table 4. There is no common terminology for steel and PEX pipes regarding insulation class, wherefore the used terminology varies between the two pipe types.

**Table 4.** Reference pipe type and insulation class for the GRUDIS and hybrid distribution concept.

	Variant	G1 (ref)	H1 (ref)
Primary	Pipe type Ins. class	PI-PEX (M2) Standard	Steel (M1) Series 1
Secondary	Pipe type Ins. class	NA NA	PI-PEX (M2) Standard

### 3.1.5. Calibration of Pipe Losses

Proper modeling of steel and PEX pipe heat losses was ensured by calibrating the specific heat losses [W/m] against values provided in manufacturer product catalogs for a specified set of boundary conditions. For copper pipes, the theoretical overall heat transfer coefficient was calculated, and the specific heat loss was derived from this for manufacturer-specified boundary conditions. This approach was chosen as the copper pipes were used in the solar thermal system and located above ground so that the catalogue values were invalid. Table 5 overviews the boundary conditions used for the pipe calibration process in TRNSYS. These values have been specified according to EN13941 or EN15632, and the listed heat transfer coefficients ( $\lambda$ -values) have been calculated by the pipe manufacturer according to formulae specified in the standard employed (depends on the manufacturer).

**Table 5.** Boundary conditions—Input values used for calibration of pipe heat losses in TRNSYS; catalogue heat transfer coefficients  $\lambda$  for pipe, soil insulation, and ground, as well as supply/return temperatures and soil cover.

Pipe Type	$T_{\text{supply}}$ [°C]	$T_{\text{return}}$ [°C]	$T_{\text{ground}}$ [°C]	Soil cover [m]	$\lambda_{\text{soil}}$ [W/m K]	$\lambda_{\text{pipe}}$ [W/m K]	$\lambda_{\text{ins}}$ [10 <sup>-2</sup> W/m K]
Steel (M1)						50.00	2.30
PI-PEX (M2)	80.0	40.0	10.0	0.8			1.99
PI-PEX (M1)					1.00	0.38	2.20
EPSPEX (M3)	70.0	40.0	6.0	0.6			3.40
Copper (M1)	85.0	45.0	10.0	0.8		365.00	2.20

The calibration process was performed in TRNSYS with a simulation period and time-step of 744 h and 0.05 h, respectively. The range of pipe sizes used in the distribution network and solar culvert were simulated iteratively under the specified boundary conditions. The insulation heat transfer coefficient ( $\lambda_{\text{ins}}$ ) was adjusted for each pipe size until the simulated and catalogue or calculated (copper pipes) values for specific heat loss were equal. The calibrated values of the heat transfer coefficients, which were the values

used in the simulation of the DH system, can be found in the calibration datasheet. This datasheet (MS Excel), which includes calculations for the copper pipes and the product catalogues containing information used in the calibration process, has been added to the data repository [26].

### 3.2. Parametric Study

Table 6 lists the pipe combinations used to simulate variants of the hybrid distribution concept, listing pipes according to their application in either the primary or secondary network. Table 7 shows an overview of the pipe combinations used to simulate variants of the GRUDIS distribution concept. Each distribution concept has one reference pipe combination/insulation class, introduced in Section 3.1.4.

**Table 6.** Hybrid variants—Overview of different pipe combinations used to simulate variations (H1–H8) of the hybrid distribution concept. The pipe types are listed according to their application in either the primary or the secondary network. Abbreviations: ins = insulation and ref. = reference.

	Variant	H2	H3	H4	H5	H6	H7	H7
Primary	Pipe type	Steel (M1)	Steel (M1)	Steel (M1)	Steel (M1)	Steel (M1)	Steel (M1)	Steel (M1)
	Ins. class	Series 2	Series 1	Series 2	Series 1	Series 2	Series 1	Series 2
Secondary	Pipe type	PI-PEX (M2)	PI-PEX (M2)	PI-PEX (M2)	PI-PEX (M1)	PI-PEX (M1)	EPSPEX (M3)	EPSPEX (M3)
	Ins. class	Standard	Plus	Plus	Mixed	Mixed	NA <sup>1</sup>	NA <sup>1</sup>

<sup>1</sup> The EPS-casing has a square cross-section, which means that the insulation class is not easily comparable to the insulation standards used for other pipes. No definition of the insulation class has been found, so this is defined as “not applicable” (NA).

**Table 7.** GRUDIS variants—Overview of different pipe combinations used to simulate variations (G1–G4) of the GRUDIS distribution concept. Abbreviations: ins = insulation and ref. = reference.

Variant	G2	G3	G4
Pipe type	PI-PEX (M2)	PI-PEX (M1)	EPSPEX (M3)
Ins. class	Plus	Mixed	NA <sup>1</sup>

<sup>1</sup> The EPS-casing has a square cross-section, which means that the insulation class is not easily comparable to the insulation standards used for other pipes. No definition of the insulation class has been found, so this is defined as “not applicable” (NA).

For the GRUDIS distribution concept, the pipe combinations used are limited to the two different PEX pipe technologies, so there are only four variants.

For all pipe sizes used in this study, M1 and M2 only provide single pipes for the largest pipe sizes used, DN90 and DN110. However, M2 offers two levels of insulation for all sizes, whereas only M1 provides a lower insulation level for the sizes DN63 and DN110. Therefore, the insulation level can be mixed and consist of two different insulation levels when using PI-PEX pipes from M1. This has been shown in Tables 6 and 7 as a “mixed” insulation class.

### 3.3. Calculation of Life Cycle Cost

The hybrid system modeled in this study was based on a real SDH system, which has been treated extensively in previous publications. One IEA report used this system as a “best-case” example for solar-assisted DH. Economic information provided cost estimates of SEK 340 million (EUR ~34 million) for the entire residential area, including the heating system, out of which the solar thermal system cost was estimated at SEK 3.3 million (~ EUR 0.33 million) [10]. However, these costs are not certain and detailed costs on both the solar energy system and the district heating subsystems are not included. Due to the difficulty in obtaining accurate and specific investment costs for the different parts of the system, the calculation of per-unit costs of heat such as LCOH is considered unfeasible in this study.

Instead, the LCC is adopted for use in this analysis. The LCC is calculated for the entire project lifetime and is the total cost when summarizing investment and capital costs, operation and maintenance (O&M) costs, re-investment costs, and residual values. Re-investment costs apply to the malfunction or replacement of components with a shorter technical lifetime than the project lifetime, while residual values are related to any components with a remaining technical lifetime at the end of the project lifetime.

The life cycle costs (LCC) can be defined according to Equation (1) [34]:

$$LCC = ICC + A + R + Res \quad (1)$$

where  $ICC$  is the initial capital cost,  $A$  is the annual O&M cost,  $R$  is the re-investment cost, and  $Res$  is the residual value. The  $LCC$  is calculated as the net present value (NPV) over the project lifetime.

The primary interest of this study was to compare two distribution concepts and, in total, 12 variants of distribution systems in terms of LCC. For this purpose, it was assumed that the annual maintenance costs were the same for both distribution concepts, while—for simplicity—the re-investment cost and residual value were zero. These three equation variables have therefore been neglected when using Equation (1). Furthermore, when evaluating the  $ICC$ , only the *differences* in construction costs between distribution concepts are included. To do this, the costs of the houses and solar collectors, as well as the boiler central illustrated in the hybrid concept (see Figure 2), are used as a basis, and only the difference in construction costs is calculated. Other  $ICCs$  related to the pipe network and financial services are included in full, as the distribution system is the main focus of this article. This is considered appropriate, as the costs of construction elements common to all variants only contribute to the absolute (total) costs, but not to evaluate the difference in costs of one distribution variant relative to another. Therefore, Equation (1) can be reformulated as presented in Equation (2):

$$LCC_{mrg} = ICC + A = \Delta ICC_{construction} + ICC_{pipe\ network} + ICC_{financial} + A_{maintenance} + A_{boiler\ fuel} \quad (2)$$

where  $LCC_{mrg}$  designates a marginal LCC. This is because of the omission of common construction costs, so the  $LCC_{mrg}$  becomes lower than the total (or actual) LCC. However, as a means of comparison,  $LCC_{mrg}$  is considered a sufficient measure. For reasons of brevity, the marginal LCC will be referred to as simply LCC for the remainder of this article.

### 3.3.1. Summary of Economic Boundary Conditions

Table 8 shows an overview of cost types and categories included in the LCC (Equation (2)) for the GRUDIS and hybrid distribution concepts. These costs will be explained in more detail in the following subsections.

**Table 8.** LCC types—Overview of cost types included in the LCC for the hybrid and GRUDIS distribution concepts. The LCC cost category is included in parenthesis under the cost type.

Cost Type	GRUDIS	Hybrid	Comment
Construction (ICC)	Larger boiler central; additional building costs apply.	Four intermediate substations; categorized into building, HVAC, and electric costs.	Differences in HVAC components and building material amount.
Pipe network (ICC)	PEX pipes for main and branch pipes. Installation costs 561 SEK/m [35,36].	Steel pipes for main and branch pipes. Installation costs according to [37].	Differences in pipe material and installation costs.
Financial (ICC)	Economic lifetime 20 years. 4% capital interest p.a. 50,000 SEK p.a. [38].	Economic lifetime 20 years. 4% capital interest p.a. 50,000 SEK p.a. [38].	Higher ICC gives higher capital interest costs.
Maintenance (A)	Inflation adjusted 2% p.a. Boiler efficiency according to Equation (3).	Inflation adjusted 2% p.a. Boiler efficiency according to Equation (3).	Boiler inspection, cleaning, and repair.
Boiler fuel (A)	Solar collector degradation 0.5% p.a. Fuel cost 305 SEK/MWh [39].	Solar collector degradation 0.5% p.a. Fuel cost 305 SEK/MWh [39].	Solar collector degradation leads to an increase in boiler fuel use.



It should be noted that the installation costs of the solar thermal system are assumed to be the same in both concepts so that only the pipe network costs of the solar culvert are included. This also applies to the costs of solar storage tanks and associated plumbing works. Furthermore, future increases in boiler fuel costs are not accounted for due to the high uncertainty associated with forecasting this. It has been assumed that the boiler fuel costs increase at the same rate as the target inflation rate, which should be 2% p.a. [36]. This means that the resulting NPV of boiler fuel costs may be somewhat conservative. Detailed cost calculation summaries for the costs included in Equation (2) and Table 2 can be found in the data repository [26].

### 3.3.2. Initial Capital Costs (ICC)

Supplementary information about calculations is available in Appendix A of the data repository [26].

The ICCs are comprised of the initial construction costs for buildings, HVAC and electric costs for heating system components, installation costs of the pipe network, and financial costs associated with raising initial capital through a loan. Note that the HVAC costs do not include the cost of solar storage tanks and plumbing work related to the connection of these. The costs for storage and associated plumbing work are assumed to be the same for both distribution concepts, as the number of tanks is identical for both concepts. The cost calculation software Wikells [25] was employed to properly calculate the investment costs related to the construction of additional buildings needed for the different distribution concepts. The program was used under instruction from an experienced calculator (Rickard Åkesson, personal communication) [40].

As shown in Table 8, different construction and pipe network costs apply according to the distribution concept.

The applicable construction and pipe network costs calculated are outlined for each distribution concept as follows:

#### **GRUDIS concept—higher boiler central and pipe installation costs**

The GRUDIS distribution concept features a large boiler central to house all solar storage tanks. As such, the costs for the boiler central are larger than in the hybrid system. However, the building envelope of the boiler central is assumed to comprise the same materials as those used in the intermediate substations of the hybrid system.

The pipe network in the GRUDIS system comprises only PEX pipes, and for the pre-insulated pipe type from M1 and M2, the largest employed pipes are only available as single pipes. The purchased length of pipe, therefore, varies depending on the pipe type and is lower for variant G4 than the others. Furthermore, double pipe trenches increase pipe installation costs for variant G1–G3 particularly, but also generally for the GRUDIS concept, due to parallel installation of the solar culvert with the main pipes (see Figure 2), which increases excavation costs.

#### **Hybrid concept—additional costs for Intermediate substation and pipe network**

The hybrid distribution concept features intermediate substations that act as a hydraulic separation between the primary and secondary network, in addition to providing space for solar storage and roof area for solar FPCs. There are four of these substations in the hybrid network, and the calculated additional investment costs that apply for the construction of one intermediate substation have been divided into the categories of building, HVAC, and electric costs. The HVAC components include a heat exchanger and other necessary components such as temperature sensors for the control system, an expansion vessel, a circulation pump, and internal piping for connecting storage, heat exchangers, and solar collectors. The labour costs associated with the installation of these components are also included. Building costs include walls, roof, and base slab, while electric costs are for lighting and connecting various components demanding power, such as control systems, pumps, etc.

The primary network of the hybrid system consists of steel main and branch pipes. The costs of these are generally higher than for PEX pipes, as both the pipe material cost and the installation cost is higher for pipes of similar size.

### 3.3.3. Annual Operation and Maintenance Costs (A)

Supplementary information is available in Appendix B of the data repository [26].

Maintenance costs were discussed with a representative for HVAC consulting company Andersson & Hultmark (P.A.-Jessen, Personal communication) [38], responsible for the design of the Vallda Heberg (hybrid) system on which this study is based.

The maintenance costs assumed are those related to the boiler, which include inspection, cleaning, and repairs. It was assumed that three person-hours are needed weekly for a boiler technician, resulting in an annual cost of approximately 50,000 SEK. Maintenance costs for house substations and intermediate substations were not included, as the house substations were assumed to be the responsibility of the house owners, and maintenance of the intermediate substations was assumed to be unscheduled, i.e., only performed when needed.

The calculations of boiler fuel costs were based on numbers for 2019 in an official report [39] from the Swedish Energy Authority. The calculation of annual boiler fuel demand was done by considering the theoretical boiler efficiency and the simulated boiler energy delivered to the fluid stream per hour, according to Equation (3).

$$Q_{fuel, boiler} = \sum_{t=1}^{t=8760} Q_{boiler}(t) \cdot \eta_{boiler}(t) \quad (3)$$

where  $Q_{fuel, boiler}$  is the boiler fuel supply,  $Q_{boiler}$  is the boiler energy to a fluid stream, and  $\eta_{boiler}$  is the calculated boiler efficiency at a given time and load.

The boiler efficiency as a function of the load factor was calculated using Equation (4) [41]:

$$\eta_{boiler} = \eta_{boiler, 100\%} \cdot (1 - e^{-K \cdot \beta}) \quad (4)$$

where  $\eta_{boiler}$  is the calculated boiler efficiency,  $\eta_{boiler, 100\%}$  is the boiler efficiency at full load,  $K$  ( $=0.140$ ) is an empirical constant, and  $\beta$  is the boiler load factor in percent. The boiler load factor is the quotient of  $Q_{boiler}$  and maximum boiler capacity ( $Q_{max} = 300$  kW).

The boiler modulation was calculated based on the minimum turndown ratio (MTR) of the boiler used in the original DH system on which this study is based (see Section 2). For every hourly value where the boiler output was above zero but lower than the minimum capacity, the output value was set to the minimum, and boiler fuel use was calculated accordingly. The hourly values were averaged over a 3 h period to account for potential fluctuations in boiler capacity within one hourly time step as a result of boiler start/stop and modulation behavior.

### 3.4. Cost Sensitivity Analysis

Due to the uncertainty in variables like interest rates, boiler fuel price, and cost estimates, it was interesting to study how the results change when these variables change. A cost sensitivity analysis has been made using a variation of these economic boundary conditions:

- Interest rate (IR): IR1, IR2, and IR3 correspond to p.a. 2%, 4%, and 6%, respectively.
- Boiler fuel cost increase (FCI): FCI1, FCI2 and FCI3 corresponding to p.a. increase of 2%, 4% and 6%, respectively.
- Economic lifetime: 20 years reference and 30 years extended.

A boiler fuel price increase of 2% corresponds to the inflation target of many central banks and represents a minimum increase in fuel price. The conversion of the energy system to mitigate climate change may increase the demand for biomass fuels for heating

purposes, so it is interesting to study how higher fuel prices affect the LCC. Regarding the pipe installation costs for EPSPEX, it should be noted that these are uncertain.

### 3.5. Key Performance Indicators (KPI)

The key figures used for evaluating results on system performance are shown in Table 9

**Table 9.** KPI—overview over key performance indicators used in this study.

$Q_{house\ tot}$	Total house (SH + DHW) energy demand in the DH network.
$Q_{solar\ st.\ loss}$	Losses from FPC solar storage plus internal connection pipes.
$Q_{BC\ loss}$	Losses from storage for ETC solar and boiler plus internal connection pipes.
$Q_{dist\ loss}$	Losses from ground buried pipes.
$Q_{ETC}$	Stored solar energy from evacuated tube collectors.
$Q_{FPC}$	Stored solar energy from flat plate collectors.
$Q_{boiler}$	Energy supplied from the boiler to flow stream, excluding losses.
LCC	Life cycle cost

## 4. Results

This section is divided into three sections; Section 4.1 presents the energy balance for the reference variant of GRUDIS and the hybrid concept, while Section 4.2 shows the LCC for the same. Section 4.3 presents how energy balance and LCC changes when insulation level changes, while Section 4.4 shows how LCC changes under different economic boundary conditions.

### 4.1. Energy Balance for Reference Pipes

Figure 7 shows the simulated annual energy balance for the two distribution concepts modeled in this study with the reference pipe combinations introduced in Section 3.1.4. The legend used refers to the KPIs listed in Section 3.2.

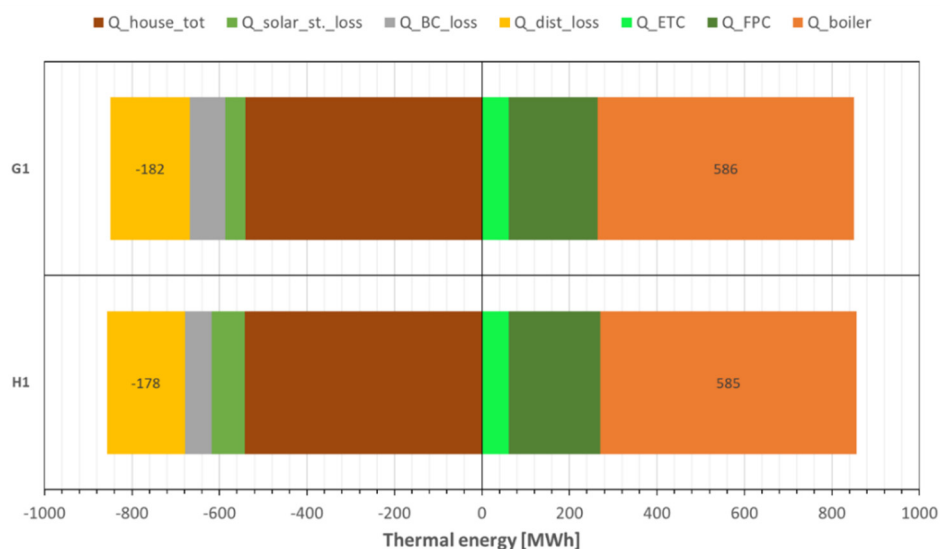

**Figure 7.** Energy balance; simulation results for the reference pipe combination/insulation class of the two distribution concepts modeled in this study, showing energy input is positive and output is negative.

From an energy perspective, the two distribution concepts seem to be performing similarly, both with regard to the energy supply and the energy demand. The main differences are observed in the solar storage and boiler central (BC) losses, where a reduction in one is accompanied by an increase in the other and vice versa. The solar storage loss is higher in the hybrid concept, partly due to the distribution of the storage volume into

smaller entities located in intermediate substations around the network. These substations contain more internal piping and other hydraulic components than the centralised solar storage solution used in the GRUDIS concept, which leads to higher associated losses. Furthermore, as the FPC solar energy is only used for heat losses in the secondary network, some of the stored solar energy could be lost due to low demand in periods of high supply. On the other hand, the boiler central loss is higher in the GRUDIS concept, mostly due to the lower operating temperatures employed, leaving more of the heat in the boiler and ETC accumulator tanks unused. However, the combined losses in solar storage and boiler central are still about 11 MWh lower in the GRUDIS concept, although this is mostly reflected in lower FPC yield and has a low effect on the boiler energy demand. It is, therefore, not clear from a purely energetic perspective which one of these distribution concepts is preferable, considering the reference pipe combination (hybrid) and insulation class.

#### 4.2. Life Cycle Cost

Figure 8 shows an overview of the calculated LCC of the two reference variants for the two distribution concepts simulated in this study. It is clear that there is a significant LCC gap between the GRUDIS and Hybrid distribution concepts. The value for LCC is SEK 15.5 M for G1 and SEK 20.4 M for H1, i.e., the LCC of G1 is 24% lower than H1. Using only PEX pipes give lower distribution pipe costs, although higher solar pipe costs lead to similar total pipe costs (SEK ~5.7 M) for the two concepts. As the boiler fuel costs also vary little between the concepts, the combined effect of higher construction costs and added financial costs as a result of this becomes an economic disadvantage of using the hybrid concept. The construction costs for expanding the boiler central in the GRUDIS concept are roughly SEK 0.4 M and make out about one-ninth (~11%) of the SEK 3.9 M applicable for the construction of four intermediate substations in the hybrid system. Due to this, the financial costs in the GRUDIS system are about 1.4 M SEK lower than those in the hybrid system, a difference of 35%. Based on these results, it is clear that the GRUDIS distribution concept is more economical.

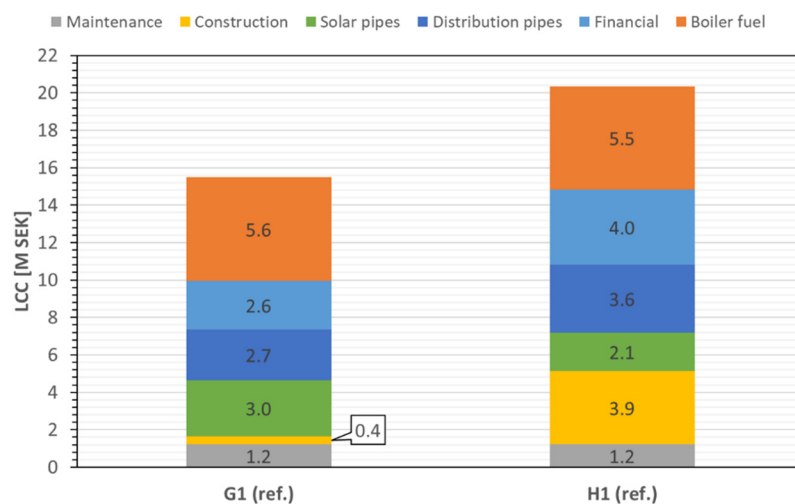

**Figure 8.** LCC analysis—Overview of the LCC of the two reference variants for the two distribution concepts simulated in this study with an economic lifetime of 20 years.

#### 4.3. Parametric Study

The parametric study shows how the energy balance (Section 4.3.1) and LCC (Section 4.3.2) vary with the employed insulation level of the pipe network for the GRUDIS and hybrid distribution concept.

#### 4.3.1. Energy vs. Insulation Level

Figure 9 shows how the supplied and lost energy changes with insulation level for the GRUDIS concept when compared to reference variant G1 (not shown). Variant G2 shows an increase in insulation level from “standard” to “plus” for the pipes (M2) used in the reference variant, which results in a reduction of 18% in distribution losses and 5% in boiler energy. Variant G3 and G4 represent a decrease and increase in insulation level, respectively. Thus, the standard insulation level in pipes by M1 is lower than that of M2 or M3. This is indicated by lower distribution heat losses for G2 and G4 and higher losses for G3 compared to the reference variant. For variant G3, the increase in distribution losses is about 16% and boiler energy 4%, while the decrease in losses is 7% and boiler energy is 2% for variant G4.



**Figure 9.** Energy balance difference—Relative changes in lost and supplied energy compared to the reference variant (G1) for the variants of the GRUDIS concept. The bold line indicates a change in pipe manufacturer; G1 and G2 employ M2, while G3 and G4 employ M1 and M3, respectively—see Table 7 for overview.

It is evident from Figure 9 that the change in boiler supplied energy is lower than the change in distribution heat loss, largely due to changes in the solar energy yield. The average boiler energy is 591 MWh, less than a percent more than for the reference variant G1. For variant G2, the lower distribution heat loss leads to lower yield during the solar heating season as there is a surplus of heat, which is seen in the increase in solar storage loss. For variant G3, the heat losses increase. This leads to an increase in solar yield and simultaneously lower losses from boiler central and solar storage, which indicates that the increased loss is covered by solar. For variant G4, the distribution losses decrease but not sufficiently to increase the boiler central and solar storage loss, implying that all of the solar heat is utilised as efficiently as in variant G1. Furthermore, the solar yield is affected insignificantly, which indicates that the solar energy harvested during the daytime is just enough to cover the load and heat loss, giving equal changes in boiler energy and distribution loss.

Figure 10 shows how the losses and supplied energy in the hybrid distribution concept change with insulation levels relative to the reference variant H1 (not shown). System variants H2–H4 show increasing insulation levels for the reference combination of steel pipes (M1) and PEX pipes (M2), while variants H5–H8 employ either M1 or M3 PEX pipes but alternates the insulation level of the steel pipes. An overview of the different variants is found in Table 6.



**Figure 10.** Energy balance difference—absolute changes in supplied and lost energy compared to the reference variant (H1) for the variants of the hybrid distribution concept. The bold line indicates a change in the manufacturer of PEX pipes; H1–H4 employs PEX M2, while H5–H8 employs M1 and M3—See Table 6 for an overview.

From Figure 10, it is clear that increasing the insulation level for steel pipes (i.e., H1 → H2) has a smaller effect on distribution losses than when increasing insulation in PEX pipes (i.e., H1 → H3). Employing M1 PEX pipes as in variant H6 corresponds to decreasing insulation level relative to H1 as the losses increase. On the other hand, the use of M3 (EPS) PEX pipes as in variant H7 is seemingly equivalent to using M2 PEX pipes with standard insulation level, as in variant H1. Variant H4 leads to the largest reduction in distribution losses (−28%) and boiler energy demand (−7%). The average boiler energy for all variants is 580 MWh, which is one percent less than for the reference variant H1. The standard deviation is about 3%, which indicates that the insulation level is of minor importance for the boiler energy demand.

By comparing Figures 9 and 10, and recalling that the distribution loss and boiler supplied energy were similar for reference variants G1 and H1 (see Figure 7), it can be seen that variant H4 is the most energy-efficient of any variant, regardless of the distribution concept. Furthermore, it appears that steel pipes with a low insulation level in the primary network of the hybrid system, as in variant H3, have nearly the same heat loss as if these pipes were PEX pipes with a higher insulation level, as in variant G2 (see Table 10). However, the additional overall heat loss in G2 is due to the additional network length necessary for the stem pipe sizes DN90 and DN110, which are only available as single pipes. If not for this, variant G2 would have the lowest losses of all variants. Nevertheless, variant H4 shows the lowest overall heat loss, followed by H3 and G2. That is, two variants of the hybrid concept lead to lower network heat losses than the best GRUDIS network. However, despite this, the variant G2 uses less boiler energy than variant H3, although the difference is too insignificant to give a definitive answer which is energetically preferable when considering uncertainty.

**Table 10.** Heat loss—Overview of the total distribution of heat loss  $\dot{Q}$ , as well as average specific heat loss  $\dot{q}$ , calculated according to network length  $L$ , for the different distribution variants simulated in this study.

Variant	H4	H3	G2	G4	H8	H2	H7	H1	G1	H6	H5	G3
$\dot{Q}$ [kW]	−15.9	−16.8	−17.0	−19.3	−19.4	−19.4	−20.3	−20.3	−20.8	−21.4	−22.4	−24.2
$\dot{q}$ [W/m]	−6.1	−6.5	−6.0	−7.5	−7.5	−7.5	−7.9	−7.9	−7.3	−8.3	−8.7	−8.5
Net. L [m]	2580	2580	2840	2580	2580	2580	2580	2580	2840	2580	2580	2840

#### 4.3.2. Costs vs. Change in Insulation Level

Figure 11 gives an overview of how the absolute costs change when insulation level changes, compared to reference variant G1 and H1 for the GRUDIS and hybrid distribution concept, respectively. According to the results, variant G4 has the largest net cost reduction compared to G1, which should largely be due to the difference in network length between variants G1–G3 and variant G4, where the latter uses twin pipes in larger dimensions (DN90 and DN110) in contrast to the former that use single pipes. The resulting increase in pipe costs due to a longer network offsets the low heat losses and correspondingly lower boiler energy costs. For the hybrid system, variant H4 yields the largest net cost reduction compared to H1.

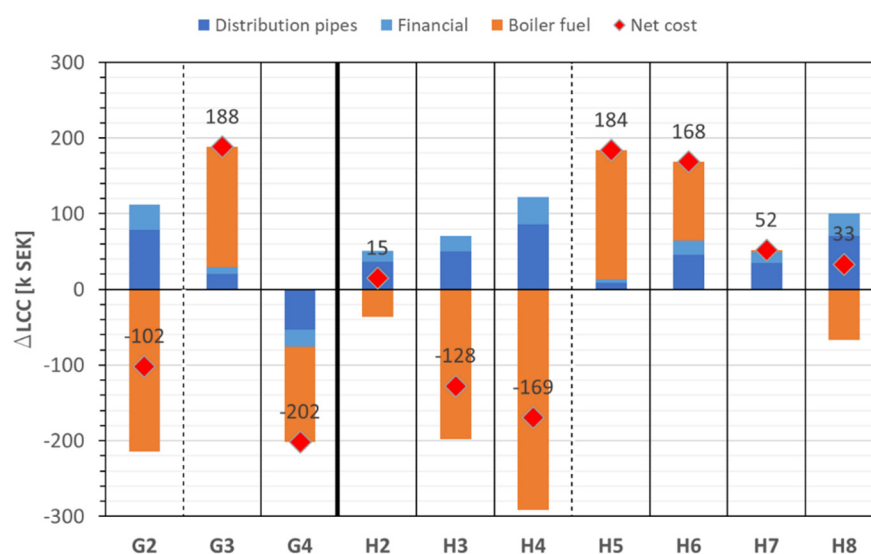

**Figure 11.** Cost difference—Absolute cost changes for the variants of the GRUDIS and hybrid distribution concept relative to the reference variant (G1 and H1, respectively). The bold line separates variants of different distribution concepts, while the stilled line separates reference pipe manufacturer(s); G2 and H2–H4 employ PEX M2, while G3 and G4 and H5–H8 employ M1 and M3—See Table 6 for an overview.

However, because the scale of the axis is two orders of magnitude lower than the scale in Figure 8, the relative influence on the total costs is in the lower one-digit range. Because the largest difference between variants within each distribution concept is less than 2%, the difference between variants within each concept is too insignificant to conclude whether it is worthwhile to invest in one over the other, particularly when considering the uncertainties in simulations and economic boundary conditions. Therefore, the average (based on all variants simulated) discrepancy in LCC for the GRUDIS distribution concept and the Hybrid concept is equal to the discrepancy between G1 and H1—24%. According to this, it can be concluded that the GRUDIS concept is more economic than the hybrid concept, regardless of insulation level.

#### 4.4. Sensitivity Analysis

The sensitivity analysis investigates the effect of variation in the boundary conditions of the economic calculations, as described in Section 3.4.

Figure 12 shows the difference in LCC between distribution concepts for reference variants G1 and H1, as well as how the LCC change (increases) when economic boundary conditions are varied for reference variants G1, H1, and the most energetically efficient variants G4 and H4. According to the results, the absolute difference in LCC between the reference concepts remains quite similar regardless of fuel cost increase (FCI), although it increases with increasing IRs. This can be explained by observing that the relative cost increase is different for the hybrid and GRUDIS concepts. Costs increase slightly faster for

GRUDIS variants G1 and G4 than they do for hybrid variants H1 and H4—with increasing fuel cost—while on the other hand, the GRUDIS variants are less sensitive to increasing IRs. This results from the differences in relative shares made out by individual ICCs in the LCC (see Figure 8).

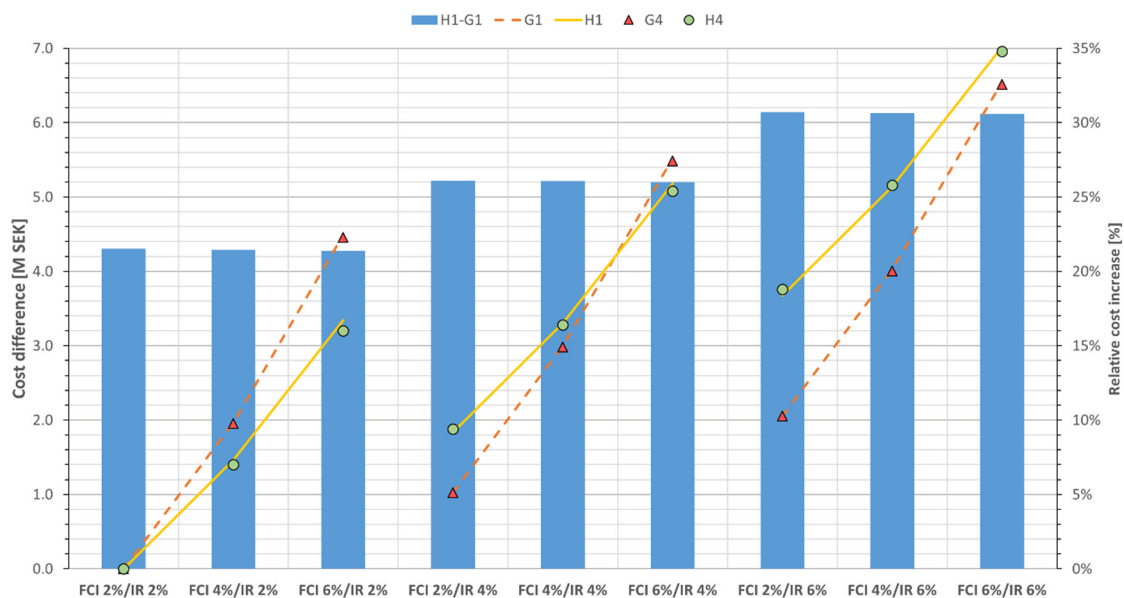

**Figure 12.** Boundary conditions—Cost difference [M SEK] between reference concepts G1 and H1, as well as relative increase [%] in total costs for variants G1, G4, H1, and H4, with changing fuel cost increase (FCI) and interest rate (IR). Relative values are calculated using FCI 2%/IR 2% as reference.

Because the absolute boiler fuel costs are very similar for the two distribution concepts, and these costs make up a significantly larger relative share of the LCC for the GRUDIS concept than for the hybrid concept, a similar absolute increase in boiler fuel costs has a larger relative impact on the increase in LCC. In the GRUDIS concept, the boiler fuel costs make out about 38% of the LCC, compared to 28% for the hybrid concept. Conversely, because the financial ICC is significantly larger in the hybrid concept than in the GRUDIS concept, a similar increase in IR has a larger relative impact on the LCC. In the hybrid concept, construction and financial ICC make out about 66% of the LCC, compared to 54% in the GRUDIS concept.

These results indicate that regardless of the boundary conditions, the GRUDIS distribution concept remains economically preferable and that the absolute cost savings are consistent over the studied range of boundary conditions.

## 5. Discussion

The discussion section mainly focuses on parts of the method and their influence on the overall results to reveal uncertainties in the results.

### 5.1. Modelling

The modeling approach can have a significant influence on the simulation results, and this is discussed here.

#### 5.1.1. Model Simplifications

Several model simplifications have been brought up in Section 3.1:

- One housing area to represent two housing areas.
- One house model to represent all houses.
- Load connected to the supply at the end of the network.



Each of these simplifications influences the result to a minor extent, which has been extensively covered in other studies relating to this system model [11,12]. The main conclusion from these was that because the modeling approach is the same for both distribution concepts, the potential effects of the modeling approach affect the results similarly for both. Hence, although the absolute values for energy quantities presented may not be entirely accurate for each respective concept, the differences in values between concepts should be considered accurate.

#### 5.1.2. Boiler Modulating Behaviour

The boiler modulation in this study was modeled by post-processing of hourly simulation output. This required simplifying the data processing method, such as adapting a 3 h moving average (MA) value to account for hourly fluctuations in boiler output. This approach is considered appropriate due to the presence of buffer storage that provides peak shaving so that the boiler rarely works at minimum capacity. The absence of storage would render proper modeling of modulation more significant.

According to information from a technician working on the system used as a case study for the hypothetical system modeled in this study, the cycling time for a pellet boiler of the employed size is 15–20 min. That is, the time from the boiler turns off below the minimum turndown ratio, is started again, and arrives at the supply target temperature. The control response time is usually in a matter of minutes, so it is possible with 3–4 boiler cycles within one hour, resulting in potentially high instantaneous loads to give a low average hourly load. In particular, a jump in the hourly supply power from a value of, e.g., 75 kW to 0 kW—or vice versa—is unrealistic, as the boiler would down-modulate as far as possible before turning off to avoid extensive cycling. In general, all fluctuations in the part-load behaviour should be of importance, such as those that move between minimum load (22.5 kW) and up to about 1/3 boiler capacity, where the boiler efficiency stabilises. In this load interval, the efficiency varies the most, and, therefore, it seems most important to model the modulation behaviour correctly here.

Nonetheless, using a 3 h MA instead of the hourly values seems to have little influence on the calculated boiler fuel use. For the GRUDIS concept, the 3 h MA leads to a roughly 2% higher annual fuel use than when using hourly values. For the Hybrid concept, the 3h MA results in 1–3% higher annual fuel use than when using the hourly values. Variations in the base value for the MA in the range 3–6 h give less than a 1%-point difference in these values, which limits the importance of modeling boiler modulation more precisely.

#### 5.2. Cost Calculations

The economic boundary conditions have the largest influence on the overall results. These are therefore subject to extra scrutiny when evaluating the results. This section focuses on the main uncertainties underlying the results and their influence on these.

##### 5.2.1. Calculations from Price List vs. from Supplier

The pipe network prices were collected by contact with the sales department of each respective manufacturer. For M2 and M3, a network schematic and list of pipe sizes was supplied to a sales representative, and a tender was received with a part specification list. For M1, a price list was handed out with information about applicable discounts for the type of pipe (steel or PEX). The tender of M2 was used as a basis for the choice of pipe parts, such as joints and reductions, as these are similar to the pipe type (PI-PEX) for both manufacturers.

Two issues that arise with the employed method of cost information gathering are:

1. Tenders from suppliers are without vendor margins (below market price).
2. Possibility of tenders being undervalued (potential market strategy).

At first glance, both of these issues seem to be two sides of the same issue. However, issue 1 refers to the challenge of knowing how the tender relates to the market prices for pipes. Issue 2, on the other hand, refers to the possibility that manufacturer sales

representatives—knowing the intended use of the cost information—could deliver lower tenders than would be the case for a client.

Although it is impossible to establish whether this happened, the small differences in pipe costs between different manufacturers observed in the LCC (see Section 4.3.2) implies that this is not the case. The similarity in costs further implies that the difference in cost calculation approach for the different manufacturers (i.e., discounts in M1 prices vs. tenders) does not influence the prices significantly either. It can be speculated upon whether the discounts omitted by M1 were a part of a market strategy to be competitive in the market, a strategy in which the calculated pipe costs in this study would seem to confirm as effective. Nevertheless, aside from speculation, the small pipe cost differences seem to reflect a healthy market with sufficient competition between manufacturers. On account of this, it is deemed improbable that the above-mentioned issues are important to the results.

### 5.2.2. Cost Level in Calculation Software Wikells

The employed cost calculation software is designed by collecting costs for vast amounts of entrepreneurial costs from various projects and companies. The cost calculations that are delivered are mostly estimates. According to professional users, every company delivering tenders with the program has its own marginal cost added to the project based on the experience from previous projects. According to these users, the actual cost may differ as much as 20–30% for some projects, which is a significant overhead. The “standard cost” or average entrepreneurial cost is more of a guideline than a real estimate.

The construction costs included in this study are based on the design of real buildings and using real wall constructions, HVAC components, and electrical installations. Access to 2017 cost data from an entrepreneur involved in building one intermediate substation equal to the ones modeled in this study shows that the actual costs of one intermediate substation were 51% more expensive than the estimate from Wikells after adjusting for inflation. This is a significant difference, and it seems that the single most important deviation from the calculated costs is due to the HVAC installation material and installation costs. Adjusting the calculated HVAC costs from Wikells per hour to correspond to the same amount of work hours as in the actual substation increases the total substation costs by 44% if all other Wikells costs are kept.

Such a massive uncertainty in costs unquestionably leads to questionable results from a cost analysis. Nonetheless, the costs of an intermediate substation only apply to the Hybrid concept. As this has already been identified as the most costly concept, the potential additional cost does not change the results. On the other hand, the uncertainties poised by using Wikells do give some room for questioning the apparent difference in LCC for the two concepts, as this may be different from that which is presented. However, even with a 51% increase in the ICC of construction (see Figure 8), the result on the LCC of the GRUDIS system is insignificant compared to the influence on the LCC of the Hybrid system, even when disregarding the financial cost increase. As such, the apparent difference in LCC between distribution concepts should do anything but decrease.

### 5.2.3. Fuel Costs

The fuel cost used as the basis for the LCC analysis was taken from costs statistics made available by the Swedish Energy Authority (Energimyndigheten) [39]. The cost development of refined and unrefined biomass fuels for the period 2011–2020 shows a falling trend in the period 2011–2017 (except for 2016), before a rise from 2018 to 2020. The average fuel cost in this period is 282 SEK/MWh, ranging from 252–332 SEK/MWh. As such, the year-to-year cost of fuel shows high variability due to various factors affecting availability, which makes it difficult to determine a representative value. However, the transition towards increased use of renewable energy is expected to increase the demand for biomass at least until 2030, which could result in increased costs [42]. The cost ultimately chosen was based on a single year (2019) as this was equal to that of 2011 (305 SEK/MWh)

before the costs started declining, and it is roughly 8% higher than the average for the historical period. This, therefore, includes some margin for higher costs in the future as the sensitivity analysis investigates the potential impacts of various annual fuel cost increase rates. Notably, the influence of the fuel cost is insignificant for the difference between distribution concepts and, therefore, the results between these. Still, it has an observable impact on the LCC and the relative share of LCC cost components. Nevertheless, seeing that the boiler fuel consumption is rather similar between the concepts, the effect of this on the results is assumed insignificant.

## 6. Conclusions

- A hypothetical district heating system has been modeled in TRNSYS using two distribution concepts; a hybrid comprised of 3rd and 4th generation DH technology and GRUDIS, which may be considered 4th generation DH technology.
- A range of pipe insulation levels has been simulated for each concept, and the average boiler-supplied energy is similar for both the GRUDIS and Hybrid distribution concepts.
- Increase/decrease in heat losses due to change in insulation levels primarily affects the boiler supplied energy and, to a minor extent, solar contribution. The reduction in boiler supplied energy is at best 5% for the GRUDIS concept and 7% for the Hybrid concept.
- The lowest pipe network losses are found for a hybrid system variant using the highest available insulation level for both steel pipes and PEX pipes. The GRUDIS variant with the lowest pipe heat loss uses the PEX pipes with the highest insulation level.
- The LCC is highest for the hybrid concept, being 20.4 M SEK on average for all variants simulated, compared to 15.5 M SEK for all variants of the GRUDIS concept—a difference of the average of 24%.
- An annual increase in fuel cost of 2–6% has a negligible influence on differences in LCC between the hybrid and GRUDIS concept, whereas an interest rate of 2–6% has a significant impact on the differences due to the larger initial capital cost associated with the construction and consequently, financing of, the hybrid system.
- Simplifications made in the modeling approach appear to have an insignificant influence on the results, as these are based on inter-comparison between systems built on the same assumptions.
- The influence of the cost calculation method appears to have little to no effect on the difference in LCC between the distribution concepts, as different types of cost input for the calculation of pipe network costs give similar results.

## 7. Future Work

As this study has focused on the best distribution concept for a new DH system with a pre-determined heat demand and solar array size, a future study should look at determining the optimum solar thermal system integration for a pre-determined distribution concept and heat demand. For DH systems built anew, solar thermal integration should be a requirement. The GRUDIS concept could have other system configurations that would lead to higher solar fractions and hence, better economy. Furthermore, due to the market share of DH already being so high in many parts of the world, there is a large amount of existing 3rd generation DH systems currently running at high temperatures and possibly wholly or in part on fossil fuels. This means installing solar can significantly reduce carbon emissions and/or heating costs, should solar heat replace other fuel. For these systems, the most techno-economic integration of solar thermal needs to be investigated to provide updated guidelines on the present economic conditions for solar-assisted DH. One related aspect of this is the influence of increasing demand on the system as the DH network expands, either due to urbanisation or the integration of low heat-density residential areas into the network. Both how the network is expanded and optimal integration of the solar thermal into the expanded system is of interest, as low-temperature networks could yield higher solar fractions and lower costs. However, more studies are required to have conclusive information on this.

**Author Contributions:** Conceptualization, M.A., C.B. and J.-O.D.; Data curation, M.A.; Formal analysis, M.A. and J.-O.D.; Investigation, M.A.; Methodology, M.A., C.B. and J.-O.D.; Software, M.A.; Supervision, C.B. and J.-O.D.; Validation, M.A.; Visualization, M.A.; Writing—original draft, M.A.; Writing—review & editing, M.A. and C.B. All authors have read and agreed to the published version of the manuscript.

**Funding:** This research received no external funding.

**Data Availability Statement:** The data presented in this study are openly available through Mendeley Data at DOI: 10.17632/n3cgckk6yx.1, [26]. This repository is linked to a related repository that contains more relevant information.

**Acknowledgments:** The authors thank the pipe manufacturers Elgocell, Logstor, and Maxitherm for providing the information necessary to complete this article. Appreciation also to Sättila Bygg for providing guidance on calculating building and HVAC costs.

**Conflicts of Interest:** The authors declare no conflict of interest.

## Nomenclature

### Abbreviations

BC	Boiler Central
DH	District Heat(ing)
DHW	Domestic Hot Water
DN	Nominal Diameter
EPS	Extruded Polystyrene
EPSPEX	EPS encased PEX pipe(s)
ETC	Evacuated Tube Collector(s)
EUR	Euro
FCI	Fuel Cost Increase
FPC	Flat Plate Collector(s)
GRUDIS	Swedish acronym for “ <u>Gruppcentraldistributionssystem</u> ”
GM	Ground Mounted
G1–G4	GRUDIS system variant 1 (reference) to 4
H1–H8	Hybrid system variant 1 (reference) to 8
HVAC	Heating, Ventilation and Cooling
ICC	Initial Capital Cost(s)
IR	Interest Rate
KPI	Key Performance indicators
LCC	Life Cycle Cost
MA	Moving Average
MTR	Minimum turndown ratio; quotient minimum/maximum possible power output.
NPV	Net Present Value
O&M	Operation & Maintenance
PI-PEX	Pre-Insulated PEX pipe(s)
PEX	Cross-linked Polyethylene
SDH	Solar district heating
SEK	Swedish Krone(s)
SF	Solar Fraction
SH	Space Heating
SS	Substation
SS-EN	Swedish Standard - Engineering Norm
ST	Solar Thermal
TMY	Typical Meteorological Year

## Symbols

A	Annual O&M cost
R	Re-investment cost
Res	Residual value
L	Length [m]
M	Million; $10^6$
Q	Heat energy [J/kWh]
$\Delta Q$	Difference in heat energy
$\dot{Q}$	Heat loss [W]
$\dot{q}$	Specific heat loss [W/m]
$\eta$	Efficiency
K	Empirical constant for use in calculation of boiler efficiency
$\beta$	Boiler load factor
t	Time [h]

## References

- Lund, H.; Werner, S.; Wiltshire, R.; Svendsen, S.; Thorsen, J.E.; Hvelplund, F.; Mathiesen, B.V. 4th Generation District Heating (4GDH): Integrating smart thermal grids into future sustainable energy systems. *Energy* **2014**, *68*, 1–11. [CrossRef]
- Mathiesen, B.V.; Bertelsen, N.; Schneider, N.C.A.; García, L.S.; Paardekooper, S.; Thellufsen, J.Z.; Djørup, S.R. *Towards a Decarbonised Heating and Cooling Sector in Europe Unlocking the Potential of Energy Efficiency and District Energy*; Aalborg Universitet: Aalborg, Denmark, 2019.
- Weiss, W.; Spörk-Dür, M. *Solar Heat Worldwide—Global Market Developments and Trends in 2020*; AEE Intec; IEA SHC: Gleisdorf, Austria, 2021.
- Eurostat. Eurostat: Just over 20% of Energy Used for Heating and Cooling is Renewable. 2019. Available online: <https://ec.europa.eu/eurostat/en/web/products-eurostat-news/-/ddn-20201229-1> (accessed on 29 April 2022).
- REN21. *Renewables 2020 Global Status Report*; REN21 Secretariat: Paris, France, 2020.
- REN21. *Renewables in Cities 2021 Global Status Report*; REN21 Secretariat: Paris, France, 2021.
- Averfalk, H.; Werner, S. Essential improvements in future district heating systems. *Energy Procedia* **2017**, *116*, 217–225. [CrossRef]
- Werner, S. Fourth Generation of District Heating Technology. Finnish District Heating Days 2017. 2017. Available online: <https://www.4dh.eu/resources/publications> (accessed on 25 November 2020).
- Mauthner, F.; Herkel, S. *IEA SHC Task 52: Solar Heat and Energy Economics in Urban Environments—Technical Report Subtask C—Part C1*; IEA SHC: Cedar, MI, USA, 2016.
- Mauthner, F.; Joly, M. *IEA SHC Task 52: Solar Heat and Energy Economics in Urban Environments—Technical Report Subtask B/C—Part B3/C2*; IEA SHC: Cedar, MI, USA, 2017.
- Andersen, M. *Solar District Heating for Low Energy Residential Areas*; Chalmers University of Technology: Gothenburg, Sweden, 2019.
- Andersen, M.; Bales, C.; Dalenbäck, J. Heat Distribution Concepts for small Solar District Heating Systems—Techno-economic study for low line Heat densities. *Energy Convers. Manag.* **2022**, *15*, 100243. [CrossRef]
- Zinko, H. *GRUDIS-Tekniken för Värmegles Fjärrvärme*; Rapport Värmegles 2004:10; Svensk Fjärrvärme AB: Stockholm, Sweden, 2004; ISSN 1401-9264.
- Zinko, H.; Bøhm, B.; Kristjansson, H.; Ottoson, U.; Råma, M.; Sipilä, K. *IEA R&D Programme on 'District Heating and Cooling, Including the Integration of CHP'; Annex VIII, District Heating Distribution in Areas with Low Heat Demand Density*; IEA DHC: Frankfurt, Germany, 2008.
- Persson, C.; Fröling, M.; Svanström, M. Life Cycle Assessment of the District Heat Distribution System—Part 3: Use Phase and Overall Discussion (10 pp). *Int. J. Life Cycle Assess.* **2006**, *11*, 437–446. [CrossRef]
- Cool, D.H. Cool DH—Cool District Heating; Innovations; Cool DH, HOR2020. 2022. Available online: <http://www.cooldh.eu/demo-sites-and-innovations-in-cool-dh/innovations/> (accessed on 3 March 2022).
- Rosa, A.D.; Li, H.; Svendsen, S.; Werner, S.; Persson, U.; Rühling, K.; Felsmann, C.; Crane, M.; Burzynski, R.; Bevilacqua, C. Annex X Final report: Toward 4th Generation District Heating: Experience and Potential of Low-Temperature District Heating. *IEA Annex X* **2014**, *205*, 107751645.
- Olsson, H.; Rosander, A. Evaluation of the Solar-Assisted Block Heating System in a Passive House Residential Area. Master's thesis, Chalmers University of Technology, Gothenburg, Sweden, 2014.
- Nielsen, C.; Haegermark, M.; Dalenbäck, J.O. Analysis of a Novel Solar District Heating System. In Proceedings of the ISES and IEA SHC International Conference on Solar Energy for Buildings and Industry, Kassel, Germany, 25–29 September 2022; pp. 16–19. Available online: <http://urn.kb.se/resolve?urn=urn:nbn:se:du-15517> (accessed on 29 April 2022).
- Andersen, M.; Bales, C.; Dalenbäck, J. Techno-economic Analysis of Solar Options for a Block Heating System. In Proceedings of the Eurosun 2016 Conference Proceedings, Palma de Mallorca, Spain, 11–14 October 2016.
- Wallentun, H.; Zinko, H. *Medieror av Plast i Fjärrvärme System, FOU 1996:8 (Swedish)*; Swedish District Heating Association: Stockholm, Sweden, 1996.

22. Gudmundson, T. *EPSPEX-Kulvert: Utveckling, Utförande Och Uppföljning*, FOU 2003:96; Swedish District Heating Association: Stockholm, Sweden, 2003.
23. Dahm, J. *Small District Heating Systems*; Chalmers Tekn. Högskola: Gothenburg, Sweden, 1999.
24. SEL; CSTB; TRNSOLAR; TESS. *TRNSYS 17, a Transient System Simulation Program—Volume 1, Getting Started*; University of Wisconsin: Madison, WI, USA, 2014; Volume 1, Available online: <http://www.trnsys.com/> (accessed on 20 May 2022).
25. Amnis Systemutveckling, Wikells Sektionsdata. 2021. Available online: <https://wikells.se/> (accessed on 29 April 2022).
26. Andersen, M. *Data for Article: 'Economic Analysis of Heat Distribution Concepts for a small Solar District Heating System'*; Mendeley Data, V1; Elsevier: Amsterdam, The Netherlands, 2022. [[CrossRef](#)]
27. Fahlén, E.; Olsson, H.; Sandberg, M.; Löfås, P.; Kilersjö, C.; Christensson, N.; Jessen, P.A. *Vallda Heberg—Sveriges Största Passivhusområde Med Förnybar Energi*; Lågan: Gothenburg, Sweden, 2014.
28. Sotnikov, A.; Nielsen, C.K.; Bales, C.; Dalenbäck, J.O.; Andersen, M.; Psimopoulos, E. Simulations of a Solar-Assisted Block Heating System. In *Proceedings of the ISES Solar World Congress 2017—IEA SHC International Conference on Solar Heating and Cooling for Buildings and Industry*, Abu Dhabi, UAE, 29 October—2 November 2017; Volume 1, pp. 373–383. [[CrossRef](#)]
29. Meteotest, v. 7.3.4. 2020. Available online: <https://meteonorm.com/en/> (accessed on 29 April 2022).
30. Jordan, U.; Vajen, K. *DHWcalc—Tool for the Generation of Domestic Hot Water (DHW) Profiles on a Statistical Basis*; Universität Kassel: Kassel, Germany, 2017; Volume 2, p. 22.
31. TRNSYS. *TRNSYS 17, a Transient System Simulation Program—Volume 4 Mathematical Reference*; Solar Energy Laboratory, University of Wisconsin-Madison: Madison, WI, USA, 2009.
32. TESS. *TESS Component Libraries—General Descriptions*; Thermal Energy System Specialists, LLC: Madison, WI, USA, 2021; p. 79. Available online: <https://www.trnsys.com/tess-libraries/> (accessed on 29 April 2022).
33. Drück, H. *Transsolar: Type 340—MULTIPOINT Store Model for TRNSYS*. 2006. Available online: [https://www.trnsys.de/static/788c19e80e1b4e690b35e44b05c8b164/ts\\_type\\_340\\_de.pdf](https://www.trnsys.de/static/788c19e80e1b4e690b35e44b05c8b164/ts_type_340_de.pdf) (accessed on 17 March 2021).
34. Gustafsson, M.S.; Myhren, J.A.; Dotzauer, E. Life Cycle Cost of Heat Supply to Areas with Detached Houses—A Comparison of District Heating and Heat Pumps from an Energy System Perspective. *Energies* **2018**, *11*, 3266. [[CrossRef](#)]
35. Elgocell, A.B.; Klingheim, M. Personal communication, 2019.
36. Sveriges Riksbank. riksbank.se; Current Inflation Rate. 2021. Available online: <https://www.riksbank.se/en-gb/monetary-policy/the-inflation-target/current-inflation-rate/> (accessed on 22 June 2021).
37. Lejenstrand, A. Welcome to Swedenergy—Energiföretagen Sverige. 2021. Available online: <https://www.energiforetagen.se/in-english/> (accessed on 23 June 2021).
38. Andersson, I.; Hultmark, A.B. Andersson & Hultmark. 2021. Available online: <http://aohab.se/> (accessed on 14 April 2021).
39. SCB. *Electricity Supply, District Heating and Supply of Natural Gas 2019, Final Statistics*; Swedish Energy Authority: Eskilstuna, Sweden, 2020.
40. Sätilla Bygg. Sätilla Bygg, satilabygg.se. 2019. Available online: <https://satilabygg.se/> (accessed on 22 June 2021).
41. Carlon, E.; Schwarz, M.; Golicza, L.; Verma, V.K.; Prada, A.; Baratieri, M.; Haslinger, W.; Schmidl, C. Efficiency and operational behaviour of small-scale pellet boilers installed in residential buildings. *Appl. Energy* **2015**, *155*, 854–865. [[CrossRef](#)]
42. Statens Energimyndighet. *Scenarier över Sveriges Energisystem 2020 (Swedish)*; ER 2021:6; Statens Energimyndighet: Eskilstuna, Sweden, 2021; ISSN 1403-1892.