

Photoexcited single metal atom catalysts for heterogeneous photocatalytic H₂O₂ production: Pragmatic guidelines for predicting charge separation

著者	Teng Zhenyuan, Cai Wenan, Sim Wenwen, Zhang Qitao, Wang Chengyin, Su Chenliang, Ohno Teruhisa
journal or publication title	Applied Catalysis B: Environmental
volume	282
page range	119589
year	2020-09-30
URL	http://hdl.handle.net/10228/00008982

doi: <https://doi.org/10.1016/j.apcatb.2020.119589>

1 **Photoexcited single metal atom catalysts for heterogeneous photocatalytic H₂O₂**
2 **production: Pragmatic guidelines for predicting charge separation**

3
4 Zhenyuan Teng^{a,d,1}, Wenan Cai^{a,1}, Wenwen Sim^a, Qitao Zhang^{b,*}, Chenyin Wang^{c,d},
5 Chenliang Su^b, Teruhisa Ohno^{a,d,*}

6 ^a*Department of Applied Chemistry, Faculty of Engineering, Kyushu Institute of Technology,*
7 *Kitakyushu 804-8550, Japan*

8 ^b*International Collaborative Laboratory of 2D Materials for Optoelectronics Science and*
9 *Technology of Ministry of Education, Institute of Microscale Optoelectronics, Shenzhen*
10 *University, Shenzhen 518060, China*

11 ^c*College of Chemistry and Chemical Engineering, Jiangsu Key Laboratory of*
12 *Environmental Engineering and Monitoring, Yangzhou University, 180 Si-Wang-Ting Road,*
13 *Yangzhou 225002, China*

14 ^d*Joint Laboratory of Yangzhou University, Kyushu Institute of Technology, Yangzhou*
15 *University, 180 Si-Wang-Ting Road, Yangzhou 225002, China*

16 ¹*These authors contributed equally.*

17
18 **Abstract**

19 A systematic investigation of electronic configuration and excitation properties is
20 extremely urgent for establishing a guideline to boost H₂O₂ production with **metal** single-
21 atom photocatalysts (M-SAPCs). Herein, a series of metal-ion incorporated M-SAPCs was
22 prepared, isolating of three transition metals (Fe, Co, Ni) and two main-group metals (In,
23 Sn) single site by pyridinic N atoms in polymeric carbon nitride (PCN) skeleton. The models
24 in which metal ions are isolated by non-defected g-C₃N₄ units (Melem_3M) are consistent
25 with the practically prepared M-SAPC in terms of band structures and electronic
26 configurations. Transition density and molecular orbital analysis revealed that the
27 atomically dispersed In (III) and Sn (IV) significantly improve the charge separation with an
28 ideal electronic configuration for the end-on adsorption of oxygen for a boosted 2e⁻. The
29 experimental charge separation properties and photocatalytic activities of M-SAPC
30 showed good accordance with the computed charge transfer profiles of Melem_3M,
31 manifesting the rationalities and validities of as-proposed guidelines.

32
33 **Keywords:** Photocatalysis, oxygen reduction reaction, H₂O₂ production, single-atom
34 catalyst, time-dependent density functional theory

1 1. Introduction

2 H₂O₂ is used as an industrially crucial oxidant and is a promising future solar fuel with
3 higher energy (60 wt.% H₂O₂, 3.0 MJL⁻¹) density than compressed H₂ gas (35 MPa, 2.8
4 MJL⁻¹) [1-4]. H₂O₂ is currently produced by an energy-consuming, waste-intensive, and
5 indirect anthraquinone method [5, 6]. Photocatalytic H₂O₂ production on semiconductor
6 materials from water and oxygen has emerged as a promising safe, environmental-friendly
7 and energy-efficient process [7-9]. To achieve a high selectivity and rate for H₂O₂
8 production, it is necessary to boost the 2e⁻ oxygen reduction reaction (ORR) [10] (eq. 1) or
9 2e⁻ water oxidation reaction (WOR) (eq. 2) [11]. A photocatalytic 2e⁻ WOR pathway is quite
10 difficult to achieve because the as-synthesized H₂O₂ will decompose at the high oxidative
11 potential (1.76 V vs. NHE) [11, 12]. Alternatively, solar H₂O₂ can be obtained from an ORR
12 via a 2e⁻ pathway [9, 10, 13-17]. Various photocatalysts such as inorganic ZnO, TiO₂, and
13 CdS and organic graphitic carbon nitride (g-C₃N₄) have been found to be active for the
14 artificial photosynthesis of H₂O₂ in a particulate system [10, 18-20]. Nevertheless, the
15 activity achieved is limited to a low level due to (1) low selectivity for the 2e⁻ process and
16 (2) the low charge separation of photocatalysts.

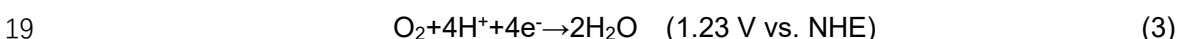
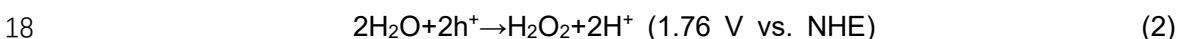
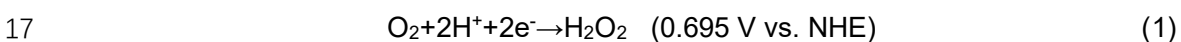

20 Tuning metallic sites into catalytic centers can boost both the activity and selectivity of
21 ORR [21]. 4e⁻ ORR and 2e⁻ ORR are two competitive reactions in electrochemical systems
22 that strongly depend on the type of O₂ adsorption [21]. O₂ adsorption on a metal surface
23 can be generally classified into three types (Scheme 1A): one end-on type (Pauling-type),
24 two side-on types (Griffiths-type and Yeager-type) [21, 22]. Side-on adsorption of O₂ is
25 used to split O-O bond, which may result high selectivity for 4e⁻ ORR, while the end-on O₂
26 adsorption can minimize the O-O bond breaking, leading to a suppressed 4e⁻ ORR (eq. 3)
27 and thus a highly selective 2e⁻ ORR [23]. Both end-on and side-on types of O₂ molecular
28 adsorption occur on the surfaces of metal particles, and thus the O-O bond splitting on the
29 surface of metal particles is therefore difficult to prevent [21-23]. On the other hand, the

1 adsorption of O₂ molecule on atomically isolated sites is usually end-on type (Scheme 1B),
2 which therefore could reduce the possibility of O-O bond breaking [24-26]. For instance,
3 supported single-atom catalysts (SACs) with Pt²⁺ [27, 28] and Co-N₄ [29, 30] centers can
4 electrochemically reduce O₂ to H₂O₂ via a 2e⁻ ORR pathway with ultrahigh selectivity
5 (>96%). Many theoretical investigations have also revealed the nature of ORR selectivity
6 to predict favorable reaction pathways for 2e⁻ ORR using a computational hydrogen
7 electrode (CHE) model [31]. However, these SACs and the CHE models is difficult to be
8 directly used in the case of photocatalytic systems since the charge separation properties
9 are not the dominant factor to influence electrochemical activity but a crucial factor to affect
10 the photocatalytic activity [32, 33]. For instance, transition metals (TMs) with the half-filled
11 d electrons, i. e., Mn, Fe, Co, Ni and Cu, usually show high activities if these elements are
12 used to construct efficient electrocatalysts [29, 30, 34], while these elements usually show
13 low photocatalytic activities because of the charge recombination occurred at these
14 metallic sites [35]. Main-group metals with a d¹⁰ electronic configuration can eliminate the
15 formation of an intermediate band in the band structure and usually show good activities
16 in many artificial photosynthesis systems [36]. A systematic investigation of electronic
17 configuration and excitation properties of isolated main-group metal and TM sites could
18 provide a comprehensive understanding between theoretical design to practical activities.

19 Here Scheme 1

20 To this end, a series of metal ion-incorporated single atom photocatalysts (M-SAPCs)
21 was prepared by a facile wet-chemical method combined with the thermal condensation
22 treatment by isolation of TM metals (Fe, Co, Ni) and main-group (In, Sn) sites with a
23 nitrogen-rich polymeric carbon nitride skeleton. The chemical states of the metal element
24 and the band positions of the catalyst were firstly investigated. Based on the experimental
25 data, we then constructed and validated cluster models that can represent the electronic
26 structure of as-prepared SAPCs. The nature of excited states (ES) was clarified in these
27 models to obtain a comprehensive understanding of possible charge separation properties
28 of M-SAPCs for the first time by employing the time-dependent density functional theory
29 (TDDFT). Verified by the experimental results of photoluminescence (PL), light-driven

1 electrochemical impedance spectroscopy (EIS) and photocurrent response profiles, a
2 theoretical guideline based on the validated electronic configuration and excitation
3 properties has been established. This guideline provides a blueprint for the design of an
4 efficient single-atom photocatalyst at atomic levels.

6 **2. Experimental details**

7 **2.1 Preparation of single metallic atom photocatalysts**

8 The purities of all reagents for preparation of photocatalysts and for
9 photoelectrochemical measurements were above analytical grade unless otherwise stated.
10 Pristine polymeric carbon nitride (PCN) was prepared by calcination of 4 g dicyandiamide
11 at 560 °C in N₂ for 4 h. Typically, FeCl₃·6H₂O (Wako Pure Chemical Industries, Ltd.),
12 CoCl₂·6H₂O (Wako Pure Chemical Industries, Ltd.), NiCl₂·6H₂O (Wako Pure Chemical
13 Industries, Ltd.), InCl₃·4H₂O (Wako Pure Chemical Industries, Ltd.) and SnCl₄·5H₂O
14 (SIGMA-ALDRICH, Co., Ltd.) were used as metallic sources for the formation of metal
15 catalytic sites. First, 1 mmol metal chloride were dissolved into ethanol solution with
16 sonification treatment for 60 min. Then, 4 g dicyandiamide was dispersed into solution by
17 sonification for another 60 min. After that, the solution was removed by a vacuum
18 evaporator, and the as-obtained powders were dried in a vacuum oven at 60 °C for 4 h.
19 The metal ion-dispersed M-SAPCs were prepared by calcinating the obtained mixture at
20 560 °C in N₂ for 4 h (Figure S1A). The as-prepared M-SAPCs were named according to
21 the incorporated metal species, i. e., Fe-SAPC, Co-SAPC, Ni-SAPC, In-SAPC and Sn-
22 SAPC. The as-prepared sample were all washed in the 2% (v/v) HCl at 80 °C for 24 h to
23 remove the unfixed metal species such as nanoparticles [29].

25 **2.2 Material characterization**

26 High-resolution transmission electron microscopy (HRTEM), high-angle annular dark
27 field scanning transmission electron microscopy (HAADF-STEM) and energy-dispersive X-
28 ray spectroscopy (EDS) were performed using a Titan Cubed Themis G2 300 electron
29 microscope (Field Electron and Ion Company, USA) with an accelerating voltage of 300 kV.

1 The crystalline phases were characterized by a powder X-ray diffraction (XRD) instrument
2 (MiniFlex II, Rigaku Co.) with CuK α ($\lambda = 1.5418 \text{ \AA}$) radiation (cathode voltage: 30 kV,
3 current: 15 mA). X-ray photoelectron spectroscopy (XPS) measurements were performed
4 using an ESCALAB 250Xi (Thermo Scientific, USA). The binding energy was calibrated by
5 taking the carbon (C) 1s peak of adventitious carbon at 284.6 eV. UV-vis diffuse reflectance
6 spectroscopy (UV-DRS) was performed using a UV/VIS/NIR spectrometer (UV-2600,
7 Shimadzu Co.). Photoluminescence spectroscopy was acquired using a FP-8500
8 spectrofluorometer (JASCO Corporation, Japan).

9 10 **2.3 Computational methods**

11 To analyze the excited states of pristine PCN and PCN coordinated with single metal
12 ions, the Gaussian09 program S2 within TDDFT was used [37]. All optimization and
13 frequency simulations were carried out by utilizing wb97xd/6-311 G(d) level of theory for C,
14 N and H elements and SDD for metal elements [9]. PCN synthesized by thermal
15 polymerization usually contains several defects and shows a poor crystallinity with a short
16 range order of the lattice [38, 39]. In this case, the single metal atom-dispersed catalysts
17 are simulated using three cluster models, which the M atom is bound with the skeleton.
18 The melem_3M represents a single metallic ion coordinated by non-defected PCN unit,
19 i.e., *graphitic carbon nitride (g-C₃N₄) unit*. The melem_4MS and melem_4MC are used to
20 simulate two possible geometry configurations of metal ions coordinated by a defected
21 PCN unit, i. e., *melon unit*. Based on the influence of ionizable groups on the isoelectric
22 points of carbon-based materials previously reported [40, 41], the incorporated metal ions
23 show positive charges in nature. In this case, the charges for cluster models are set to be
24 the same as the chemical states which are confirmed by XPS measurements. The stability
25 of SACs is evaluated by calculating the formation energy [29], which is defined as:

$$26 \quad E_{\text{form}} = E_{\text{Melem}_x\text{M}} - E_{\text{Melem}_x} - E_{\text{M}},$$

27 where $E_{\text{Melem}_x\text{M}}$, E_{Melem_x} , and E_{M} represent the energies of metal ion coordinated by PCN,
28 pristine PCN, and metallic ions.

29 Multiwfn Ver. 3.6 (released on May 21, 2019) was used for analysis of the excitation

1 and charge transfer properties [42]. The charge transfer (CT) length in the Cassian
2 coordinates (X/Y/Z) could be measured by the distance between the centroid of hole and
3 electron in the corresponding directions (denoted as D index) [37, 42]. Furthermore,
4 Coulomb attraction between hole and electron (exciton binding energy) was also computed
5 for estimation of charge recombination properties [43, 44].

6 Visualization of holes, electrons and transition density was also performed by Multiwfn:
7 functions of $IOP(9/40=3)$ were set during the vertical excitation based on TD-DFT
8 calculation [42]. The electron distributions at these excited states were presented as
9 heatmaps by using the combination of GaussView 5.0 and Multiwfn. The iso-surface of
10 LUMO orbitals was presented by setting the isovalue to 0.05.

11

12 **2.4 Activity measurements**

13 Each catalyst (50 mg) was added to 10% ethanol solution (3 mL ethanol with 27 mL
14 deionized water) in a borosilicate glass bottle (ϕ 45 mm; capacity, 50 mL), and the bottle
15 was sealed with a rubber septum cap. The catalyst was dispersed well by ultrasonication
16 for 15 min, and O_2 was bubbled through the solution for 30 min. The bottle was immersed
17 in a temperature-controlled air bath at 298 ± 0.5 K with wind flowing and was photo-
18 irradiated at $\lambda > 420$ nm using a 500 W Xe lamp (PXE-500, USHIO Inc.) with magnetic
19 stirring. The amount of H_2O_2 was determined by a colorimetric method using PACKTEST
20 (WAK- H_2O_2 , KYORITSU CHEMICAL-CHECK Lab., Corp.) equipped with a digital
21 PACKTEST spectrometer (ED723, GL Sciences Inc.).

22

23 **3. Results and discussion**

24 **3.1 Characterization of M-SAPCs**

25 The crystalline structures of M-SAPCs were firstly investigated by XRD measurements
26 (Figure S1B). XRD patterns of all M-SAPC samples showed two characterization peaks at
27 about 27.4° and 13.1° , ascribing to the interlayer stacking {002} and the inner planar
28 structure packing {100} of tri-s-triazine units, respectively. The slight shift in the diffraction
29 pattern of the {002} lattice compared with the XRD pattern of pristine PCN (27.6°) can be

1 attributed to the electrostatic repulsion between interlayers when positive ions were
2 incorporated into the PCN matrix [9]. Although the peak intensities of the {002} lattice
3 slightly changed after the introduction of heterometal ions, there was almost no change in
4 the peak intensity of the {100} lattice, indicating that the incorporation of metal species has
5 almost no influence on the in-plane structure of tri-s-triazine [20]. As a powerful tool for
6 discerning individual heavy atoms, high-angle annular dark-field scanning transmission
7 electron microscopy (HAADF-STEM) was used to further confirm the morphology and
8 elemental distribution and configuration of metal species. The morphologies of pristine
9 PCN (Figure 1A) and all M-SAPCs were bulk materials with a homogeneous distribution of
10 metal elements as shown in the HAADF-STEM mapping images with low magnification
11 (Figure S2). After aberration-correction TEM measurement in high magnification, Figure
12 2B-F show that the bright spots with high density corresponding to metallic atoms are
13 uniformly dispersed in the carbon nitride matrix. The size distribution inserted in Figure 2B-
14 F reveals that the size of 99.6% of the metallic species is less than 0.2 nm, manifesting
15 that incorporated metal exists exclusively as atomically dispersed single atoms [45]. The
16 weight percentages of the metal species in the as-prepared M-SAPCs are all less than 1%
17 (Table S1) with a similar amount of metal atom in a certain mass of catalyst (about 0.5~0.6
18 mmol per 1 g catalyst). Note that metal nanoparticles could remain on the surface of M-
19 SAPC (taking In-SAPC as an example) if the as-prepared photocatalyst did not undergo
20 the acid washing process (Figure S3).

21 **Here is Figure 1.**

22 To further reveal the interaction between the isolated metallic sites and the PCN
23 skeleton, chemical states of pristine PCN and M-SAPCs were investigated by XPS
24 measurements. The ratio obtained by dividing the integration area of the C 1s peak by the
25 integration area of N 1s was almost constant in the XPS survey spectra of pristine PCN
26 and M-SAPC (Figure 2G), further indicating that incorporation of isolated metallic ion sites
27 has almost no influence on the skeleton of PCN matrix. As shown in the high-resolution C
28 1s spectra of pristine PCN and M-SAPC (Figure S4), the typical components around 288.1
29 eV and 284.6 eV (indexed as N-C=N and adventitious carbon, respectively) are almost

1 the same, whereas no new peak appeared in C 1s spectra. These results revealed that the
2 chemical state of surface carbon remained almost the same, indicating that the carbon
3 atoms hardly interact with metallic ions. Three peaks at 401.0 eV, 399.8 eV and 398.7 eV
4 can be assigned to -NH₂, tertiary nitrogen, and C=N-C bonds, respectively. It is notable
5 that nitrogen peak (N 1s) appears around 398.3 eV in the spectra of M-SAPC, which could
6 be assigned to the chemical composition of N-Metal (Figure 2H) [46]. High-resolution Cl
7 2p spectra (Figure S5) confirmed that all fluoride elements were completely removed,
8 excluding the possibility of chemical states of M-Cl. The spectra of Fe 2p can be
9 deconvoluted to six peaks at 728.0 eV, 724.0 eV, 722.0 eV, 715.2 eV, 711.2 eV and 709.2
10 eV (Figure S6A), which could be respectively assigned to the satellite peak of Fe 2p_{1/2},
11 Fe³⁺-N 2p_{1/2}, Fe²⁺-N 2p_{1/2}, satellite peak of Fe 2p_{3/2}, Fe³⁺-N 2p_{3/2} and Fe²⁺-N 2p_{3/2}, which
12 is close to the binding energy of Fe₂O₃ and FeO. These results revealed that that the
13 chemical states of Fe is mixed with (II) and (III). Similarly, referring to the chemical states
14 of CoO, NiO, In₂O₃ and SnO₂, the chemical states of atomically dispersed Co, Ni, In and
15 Sn species in the as-prepared M-SAPC are close to (II), (II), (III) and (IV) (Figure S6B-E),
16 respectively [46].

17 Here is Figure 2.

18 To investigate the bandgap width, CBM and VBM of the as-prepared M-SAPC samples,
19 UV-vis DRS, Mott-Schottky and VB-XPS measurements were respectively conducted. As
20 shown in Figure 2A, the light absorption edge of pristine PCN (445 nm) is smaller than that
21 of M-SAPCs (> 450 nm), indicating that the incorporation of metal ions narrowed the band
22 gap. The band gap width followed a sequence of $E_{gIn-SAPC} > E_{gNi-SAPC} \approx E_{gCo-SAPC} > E_{gSn-}$
23 $SAPC > E_{gFe-SAPC}$. The VBM of M-SAPCs remained almost constant to be 1.46 eV as shown
24 in the VB-XPS results (Figure S7). As shown in Mott-Schottky plots (Figure S8), the CBM
25 of M-SAPC samples gradually became more positive from -1.28 eV for pristine PCN to -
26 1.00 eV for M-SAPCs (Figure S8). Based on as-obtained bandgap width and band
27 positions, band diagrams of M-SAPCs and pristine PCN can be presented as shown in
28 Figure 2B. The introduction of isolated metal ions resulted in a more positive conduction
29 band minimum, indicating that intermediate band may be introduced by single metallic sites.

1 Being specific, the introduction of Fe^{2+} and Fe^{3+} , Co^{2+} , Ni^{2+} , In^{3+} and Sn^{4+} sites respectively
2 shifted the CBM of the as-prepared catalyst for +0.28 eV, +0.21 eV, +0.19 eV, +0.09 eV
3 and 0.24 eV. Based on the characterization details shown above, we can confirm that the
4 metal ions were isolated by the nitrogen atoms of PCN skeleton with a little influence on
5 the CBM. However, it is difficult to obtain the rigorous coordination status of isolated metal
6 ions and N atoms since there are several possible structures of polymeric carbon nitrides
7 prepared by thermal polymerization [38, 39]. In this case, a detailed theoretical simulation
8 of M-SAPCs is necessary to reveal the comprehensive influences of isolated metal sites
9 on the electronic configuration, thus leading to a further validation the structure of isolated
10 metallic sites and a deep understanding of the changes in charge separation properties of
11 M-SAPCs.

12

13 **3.2 Development and validation of cluster models**

14

Here is Figure 3.

15 Transition metals such as Fe, Cu, Zn, and Ni, and so forth have been used to construct
16 models of single catalytic sites [34]. Based on previous experimental and theoretical results
17 [34, 39], the skeleton of PCN can formed pores filled with six nitrogen lone-pairs of
18 electrons in 2D planes, which is favorable ion coordination [39]. Additionally, the PCN
19 prepared by thermal polymerization at high temperature showed the existence of $-\text{NH}_2$ as
20 revealed in deconvoluted peak at 401.0 eV (Figure 1H). Previous reports showed that the
21 mass ratio of the H element in PCN prepared by a thermal polymerization strategy is above
22 1.0% or more, quite close to that of poly(aminoimino)heptazine, i.e., melon (the hydrogen
23 content of melon is approximately 1.5wt%) [38]. These facts suggest that melon could also
24 exist in the M-SAPC matrix. In this case, two cluster models of Melem_3 (Figure 3A, left;
25 Figure S9A) and Melem_4 (Figure 3A, Right; Figure S9B) [47] were built to represent the
26 non-defected $g\text{-C}_3\text{N}_4$ units and melon units in the material matrix, respectively. Metal ions
27 are coordinated by N atoms of Melem_3 and Melem_4 form single atomic sites.
28 Distinguished by the geometry position of the metal ions, three models that represent
29 single-atom photocatalysts could be built as well. It should be noted that the introduction

1 of cations usually results in localized charge sites in the PCN matrix. In this case, the
2 charges and multiplicities of cluster models were set by referring to the chemical states of
3 incorporated metals. Aiming to assess the stability of M-SAPCs, the formation energies of
4 metal ions embedded in the Melem_3 and Melem_4 models were calculated. As shown in
5 [Figure 3B](#), all of the values of formation energy are negative, suggesting that the
6 coordination of metal ions with nitrogen is thermodynamically favorable. These results
7 indicate that both g-C₃N₄ units and melon units could stabilize metal ions by forming strong
8 metal-nitrogen bonds.

9 The energy difference between the ionization potential (IP) and electron affinity (EA)
10 usually corresponds to the band gap of material. Thus, the band gap is equivalent to, at
11 the material level, the molecular fundamental gap. In this case, the fundamental gap
12 usually approximately corresponds to the HOMO–LUMO gap [48]. In this work, wb97xd—
13 a function with large amounts of Hartree–Fock (HF) exchange—was used to simulate the
14 charge transfer densities during the excitation. Previous works revealed that this function
15 usually overestimates the HOMO-LUMO gap and excitation energies in the case of p-
16 conjugated polymers. Additionally, p-conjugated molecules adjacent to the one carrying a
17 charge do strongly polarize (about 2 eV) in the solid state [48]. Although the computed
18 HOMO-LUMO gap is considerably larger than the experimentally measured band gap, the
19 relative changing tendencies of HOMO-LUMO gaps can still reveal the influence of ion
20 incorporation if the same function and basis are used. In this case, the energetic levels of
21 HOMO and LUMO of Melem_3, Melem_4, Melem_3M, Melem_4MC, and Melem_4MS
22 were symmetrically investigated ([Table S2](#)) to reveal the influence of metal ions on the
23 electronic configurations combined with density of states analysis, thus to validate the
24 clusters models by estimating the correlations with experimental results.

25 Melem_3 and Melem_4 show similar HOMO and LUMO positions with similar HOMO-
26 LUMO gaps of 7.61 eV and 7.73 eV, respectively, indicating that both the g-C₃N₄ units and
27 melon units in the PCN matrix have similar electronic configurations. The N 2p states and
28 C 2p states contribute to HOMO~HOMO-4 and LUMO~LUMO+4, respectively, indicating
29 that N 2p states and C 2p states fundamentally compose the VB and CB of pristine PCN.

1 The introduction of metal ions into g-C₃N₄ units (Melem_3M) have almost no effect on the
2 orbital composition of HOMO~HOMO-4, which is in accordance with the almost constant
3 VBMs of M-SAPCs (Figure S4). The introducing the metal ions result in several
4 intermediate energy levels which is 0.5 ~ 2 eV lower than the lowest energy level
5 dominated by C 2p state (The amplified DOS curves of incorporated metals are inserted in
6 the Figure 3C-H). Most of newly formed energetic levels compose LUMO levels, leading
7 to narrowed HOMO-LUMO gaps (Figure 3C-H) compared with that of Melem_3 (Figure
8 S10), which is in accordance with the experimental results (Figure 2B). On the other hand,
9 the HOMO levels of Melem_4MS (Figure S11) and Melem_4MC (Figure S12) are
10 significantly shifted after the introduction of metallic ions, due to the formations of new
11 energetic levels composed by N 2p or M 3d states. Additionally, several intermediate
12 energetic levels also appeared between the HOMO of Melem_4MS and that of
13 Melem_4MC (These energy levels all formed LUMO of Melem_4M.), leading to a
14 significantly narrowed HOMO-LUMO gap that is even smaller than the experimental band
15 gap. The normalized LUMOs of Melem_3M, Melem_4MS and Melem_4MC (M being Co²⁺,
16 Ni²⁺, In³⁺, and Sn⁴⁺) are summarized in Figure S13. The experimental CBMs of M-
17 SAPCs and pristine PCN (black line) were also summarized for comparison. The changing
18 tendency of LUMOs in the simulation results indicates that only the metal ions isolated by
19 Melem_3 units (red line) show acceptable in accordance with M-SAPCs in terms of HOMO-
20 LUMO positions for theoretical simulation and band positions for experimental results (The
21 interrelationship between the HOMO-LUMO gap is explained in the beginning of this
22 section). In this case, although the coordination of metal ions with melon units is
23 thermodynamically acceptable, the band structures and electronic configurations show
24 poor relationships with experimental band diagram. Therefore, cluster models of
25 Melem_3M were utilized for simulating the influence of isolated metal sites on the excitation
26 properties of M-SAPCs.

27

28 **3.3 Molecular orbitals and transition densities**

29

Here is Figure 4.

1 Visible light irradiation is used for photocatalytic H₂O₂ since UV irradiation ($\lambda < 400$ nm)
 2 will drastically decompose H₂O₂ generated by 2e⁻ ORR [10, 49]. In case of PCN and its
 3 derives, the adsorption edge is near 450~470 nm, i. e., the excitations with low energy play
 4 crucial roles in the visible light-driven H₂O₂ production [49]. In this case, the lowest-lying
 5 electronic transition computed by TDDFT usually represents the most possible excitations
 6 which can generate the electron hole pairs for photocatalytic 2e⁻ ORRs when using PCN
 7 and its derivatives [49]. In this work, the first 5 excited states (ES1-ES5, ES1 referring to
 8 the excited state 1 with the lowest excitation energy) of Melem_3 and Melem_3M were
 9 computed to investigate the most possible excitation properties and electronic transition
 10 properties [45]. The excitation energies of ES1 to ES5 are summarized in Figure S14. The
 11 computed optimal gap of Melem_3 is slightly larger than the experimental band gap, due
 12 to the fact that wb97xd contains a large amount of HF exchange. Therefore, the changing
 13 tendency of excitation energy was compared with the changing tendency of HOMO-LUMO
 14 gap, which is used to give an approximation for E_{fund}, leading to a primary understanding
 15 of the electron-hole pair binding energy (E_b, E_b is rigorously defined as: E_b = E_{fund} – E_{opt}, in
 16 which E_{opt} is the energy difference between ES0 and ES1.) In this work, the approximated
 17 binding energy of electron-hole pairs (E_{abX}) in each excited state is defined as follows:

$$18 \quad E_{abX} = E_{HOMO-LUMO} - E_{ecX}$$

19 where E_{abX} and E_{ecX} refer to the approximated binding energy of electron-hole pairs and
 20 the excitation energy of excited state No. X, respectively (Figure 3A). The E_{abX} values of
 21 Melem_3 and Melem_3M are shown as in Figure 3B. With the incorporation of Fe²⁺, Fe³⁺,
 22 Co²⁺ and Ni²⁺, E_{abX} of Melem_3M significantly increased. On the other hand, Melem_3In³⁺
 23 and Melem_3Sn⁴⁺ showed similar values of E_{abX}, which are both smaller than E_{abX} of
 24 Melem_3. These results indicate that the charge recombination may be suppressed by the
 25 introduction of In³⁺ and Sn⁴⁺ into g-C₃N₄ units, whereas the incorporation of Fe²⁺, Fe³⁺,
 26 Co²⁺, and Ni²⁺ could result in a thermodynamically recombination tendency.

27 The distribution heatmaps of photo-generated electrons and holes (electronic
 28 transition densities) of Melem_3M were further investigated to identify the excitation types
 29 and to predict the spatial charge separation of the M-SAPCs. As shown in Figure S15 and

1 [Figure S16](#), the distribution of electrons and holes at the first 5 ESs for Melem_3Fe2+,
2 Fe3+, Co2+, and Ni2+ is extremely localized. Both the electrons and holes are distributed
3 in a very small region just near the metal sites, indicating that typical localized transitions
4 occurred. On the other hand, the lowest energy transitions (ES1-ES5) in Melem_3In3+ and
5 Melem_3Sn4+ are dominated by charge transfer excitations, which are mostly associated
6 with In and Sn atoms ([Figure S17](#)). To quantitatively investigate the charge separation
7 properties of Melem_3M, the D index (i. e., the distance between the two barycenters of
8 electrons or holes) and the Coulomb attraction between holes and electrons (E_{Coulmb} , also
9 called exciton binding energy) were further computed ([Figure 5G-H](#)). D index and E_{Coulmb}
10 of melem_3 were also computed for comparison. As given in Figure 5G-H, the transition
11 distance of electron-hole pairs in Melem_3In3+ and Melem_3In4+ drastically increased
12 compared with that in Melem_3 and considerably larger than most of the D index values
13 of Melem_3Fe2+, Fe3+, Co2+, and Ni2+. E_{Coulmb} values of Melem_3In3+ and
14 Melem_3In4+ were almost same as that in Melem_3, while E_{Coulmb} values of Melem_3Fe2+,
15 Fe3+, Co2+, and Ni2+ drastically increased. These results further verified the charge
16 separation tendency revealed by E_{abX} , further suggesting that charge separation of
17 atomically dispersed In and Sn sites can significantly facilitate charge separation and
18 suppress charge recombination. Note that 60%~70% of the electronic densities are
19 concentrated at In sites, while only 40%~50% of the electrons are accumulated at Sn sites.
20 Thus, with the help of obvious differences among the E_{abX} , D index, and E_{Coulmb} values of
21 Melem_3 and Melem_3M, the highly concentrated electrons in Melem_3In3+ and
22 Melem_3Sn4+ predict a much higher charge separation efficiency of In-SAPC and Sn-
23 SAPC than that of Fe-SAPC, Co-SAPC and Ni-SAPC.

24 **Here is Figure 6.**

25 To further determine the influence of metal atoms on photo-redox reactions, the
26 contribution of molecular orbitals (MOs) to holes and electrons from ES1 to ES5 of
27 Melem_3M were investigated ([Tables S3-4](#)). Several MOs with energetic levels equal to or
28 lower than the HOMO all contribute to holes (ranging from 0% to ~60%), while the LUMO
29 is dominant for electron in ES1-ES3 of Melem_3In3+ and in ES1-ES5 of Melem_3Sn4+

1 (> 90%). These observations suggest that the electronic configuration of LUMO can almost
2 represent the photogenerated electronic configuration if the electrons are accumulated to
3 the atomic sites. Thus, the iso-surface of LUMO of Melem_In3+ and Melem_3Sn4+ was
4 plotted as shown in [Figures 6A-B](#). It can be clearly seen that electrons are concentrated at
5 the In and Sn sites. The photo-generated electrons tend to form a highly condensed region
6 atomic sites of In and Sn. The iso-surface of LUMO also showed that the electrons tend to
7 form a highly condensed region in In sites during the excitation. Furthermore, the iso-
8 surface of Melem_3In3+ and Melem_3Sn4+ showed an ideal electronic configuration for
9 the adsorption of electrophilic oxygen, indicating that the ORR reduction could be
10 accelerated at In and Sn sites ([Figures 6C-D](#)).

11

12 **3.4 Experimental charge separation properties and activity for H₂O₂ production**

13

Here is Figure 7.

14 To verify the theoretical prediction of charge separation efficiency obtained from the
15 simulation of molecular orbitals and transition densities, the photochemical properties of
16 as-prepared M-SAPCs were measured. As shown in the photoluminescence (PL) spectra
17 ([Figure 7A](#)), the PL intensities of Sn-SAPC and In-SAPC were significantly decreased,
18 indicating drastically suppressed charge recombination. On the other hand, the PL
19 intensities of Fe-SAPC, Co-SAPC and Ni-SAPC all increased obviously, manifesting that
20 the introduction of Fe, Co, and Ni ions into the PCN matrix facilitates charge recombination.
21 The PL intensity (I_{M-SAPC}) of M-SAPC follows a sequence of $I_{Co} > I_{Fe} > I_{Ni} > I_{Sn} > I_{In}$, being in
22 accordance with the E_{abx} ($E_{abCo} \approx E_{abNi} > E_{abSn} \approx E_{abIn}$) as shown in [Figure 2](#). As shown in
23 Nyquist plots, the diameter of the semicircle (In-SAPC) was the smallest ([Figure 7B](#)),
24 indicating that In-SAPC showed the best charge transfer. Moreover, photocurrent (I_{ph})
25 measurements of the samples showed a significant increase in I_{ph} of In-SAPC and Sn-
26 SAPC ([Figure 7C](#)), indicating enhanced efficiency of charge separation. On the other hand,
27 the incorporation of Fe, Co, and Ni ions weakened I_{ph} , indicating significantly promoted
28 charge recombination. The photocatalytic activity for H₂O₂ production ($\lambda > 420$ nm) of
29 pristine PCN and as-prepared M-SAPC samples were measured with 10% (v/v) ethanol as

1 an electron donor. After 3 reproductive experiments (Figure 7D and Figure S18), In-SAPC
2 and Sn-SAPC showed superior photocatalytic activity among all of the M-SAPC samples,
3 while the atomically dispersed Fe, Co, and Ni sites all drastically decreased the
4 photocatalytic activity compared with that of pristine PCN, which is consisted with both
5 experimental and theoretical charge separation properties. The performance of the In-
6 SAPC remained >90% after 5 repetitive photocatalytic reactions (Figure S19). After 5
7 reaction circles, the crystallinity of In-SAPC showed no obvious change (Figure S20A), and
8 the chemical states of N, C and In kept almost constant (Figure S20B-D). These results
9 indicate that the In-SAPC showed good stability during the photocatalytic activity. Note that
10 the metal particle may also sever as co-catalyst during photocatalytic reactions. Thus, the
11 activity of metal nanoparticle loaded PCN were also measured to investigate whether
12 nanoparticle could contribute to photocatalytic H₂O₂ production. Since In-SAPC is the most
13 efficient photocatalyst in this work, 3, 5, 10 mmol were mixed with melamine to prepare the
14 In nanoparticle loaded PCN (Figure S21A-C). The photocatalytic H₂O₂ production
15 significantly decreased (Figure S21D) with the addition of increasing amount of metal
16 source (InCl₃). These results indicated that the remained In nanoparticles significantly
17 suppressed the photocatalytic synthesis of photocatalytic activity. From the results above,
18 experimental charge separation properties of M-SAPC showed good accordance with the
19 computed charge transfer profile of Melem_3M. The correlations among activity and
20 experimental and theoretical charge separation properties also manifested the rationalities
21 of the proposed model and methodology for estimating charge separation properties.

22 23 **4. Conclusion**

24 In summary, a series of metal ion-incorporated single-atom photocatalyst (M-SAPCs)
25 was prepared by isolating TM metal (Fe, Co, Ni) and main-group (In, Sn) sites with pyridinic
26 N atoms in PCN skeleton. The chemical state of atomically dispersed Fe is between (II)
27 and (III), and the chemical states of Co, Ni, In and Sn species catalyst is close (II), (II), (III)
28 and (IV), respectively. The simulation results revealed that the metal ions isolated by non-
29 defected Melem_3 units are consistent with the practically prepared M-SAPC in terms of

1 band structures and electronic configurations. E_{abX} , transition density distribution of
2 elections and holes, D index and E_{Coulmb} revealed that the incorporation of atomically
3 dispersed main-group metals (In (III) and Sn (IV)) significantly improved the charge
4 separation efficiency. Additionally, the iso-surface of the dominant MO (electrons) in the
5 models of Melem_3In3+ and Melem_3Sn4+ showed an ideal electronic configuration for
6 the adsorption of electrophilic oxygen, indicating that the ORR reduction could be
7 accelerated by In and Sn sites. Furthermore, the experimental charge separation
8 properties of M-SAPCs showed good accordance with the computed charge transfer profile
9 of Melem_3M. The correlations among activity and experimental and theoretical charge
10 separation properties also showed the rationalities of the proposed model for estimating
11 charge separation properties. Our work provides not only a theoretical guideline based on
12 the validated electronic configuration and excitation properties but also a blueprint for the
13 design of single-atom photocatalyst with a high charge separation profile at atomic levels.
14 Combined with the traditional simulation strategies such as CHE models and transition
15 states, a precise benchmark for predicting both activity and selectivity might be established
16 for many artificial photo-synthesis systems in a very near future.

19 **Acknowledgement**

20 The authors acknowledge the financial support of Mitsubishi Chemical Corporation, JSPS
21 Grant-in-Aid for Scientific Research (B, No. 20H02847), Grant-in-Aid for JSPS Fellows
22 (DC2, 20J13064), Project National Natural Science Foundation of China (21805191,
23 21972094), the Guangdong Basic and Applied Basic Research Foundation
24 (2020A151501982), Shenzhen Pengcheng Scholar Program, Shenzhen Peacock Plan
25 (KQJSCX20170727100802505, KQTD2016053112042971). The authors thank Dr. Nan
26 Jian from the Electron Microscope Center of the Shenzhen University for his help in
27 HRTEM measurement.

29 **Author Contribution**

1 Zhenyuan Teng: Conceptualization, Methodology, Software, Formal analysis, Writing -
2 original draft, Data curation. Wenan Cai: Investigation, Software, Formal analysis, Data
3 curation. Wenwen Sim: Software, Formal analysis, Chengyin Wang: Writing - review &
4 editing. Qitao Zhang: Conceptualization, Supervision, Software, Writing - review & editing.
5 Chenliang Su: Writing - review & editing. Teruhisa Ohno: Conceptualization, Writing -
6 review & editing, Funding acquisition, Data curation.

7

8 **Declaration of Interests**

9 The authors declare no competing financial interest.

10

11 **References**

- 12 [1] K.P. Bryliakov, Catalytic asymmetric oxygenations with the environmentally benign oxidants
13 H₂O₂ and O₂, Chem. Rev., 117 (2017) 11406-11459.
14 <https://doi.org/10.1021/acs.chemrev.7b00167>.
- 15 [2] S.J. Freakley, Q. He, J.H. Harrhy, L. Lu, D.A. Crole, D.J. Morgan, E.N. Ntainjua, J.K.
16 Edwards, A.F. Carley, A.Y. Borisevich, C.J. Kiely, G.J. Hutchings, Palladium-tin catalysts for the
17 direct synthesis of H₂O₂ with high selectivity, Science, 351 (2016) 965-968.
18 <https://doi.org/10.1126/science.aad5705>.
- 19 [3] H.B. Gray, Powering the planet with solar fuel, Nat. Chem., 1 (2009) 7-7.
20 <https://doi.org/10.1038/nchem.141>.
- 21 [4] S.A. Mousavi Shaegh, N.-T. Nguyen, S.M. Mousavi Ehteshami, S.H. Chan, A membraneless
22 hydrogen peroxide fuel cell using Prussian Blue as cathode material, Energy Environ. Sci., 5
23 (2012) 8225-8228. <https://doi.org/10.1039/C2EE21806B>.
- 24 [5] S. Yang, A. Verdager-Casadevall, L. Arnarson, L. Silvioli, V. Čolić, R. Frydendal, J.
25 Rossmeisl, I. Chorkendorff, I.E.L. Stephens, Toward the decentralized electrochemical
26 production of H₂O₂: A focus on the catalysis, ACS Catal., 8 (2018) 4064-4081.
27 <https://doi.org/10.1021/acscatal.8b00217>.
- 28 [6] Y. Yi, L. Wang, G. Li, H. Guo, A review on research progress in the direct synthesis of
29 hydrogen peroxide from hydrogen and oxygen: Noble-metal catalytic method, fuel-cell method
30 and plasma method, Catal. Sci. Technol., 6 (2016) 1593-1610.
31 <https://doi.org/10.1039/C5CY01567G>.
- 32 [7] H. Hou, X. Zeng, X. Zhang, Production of hydrogen peroxide by photocatalytic processes,
33 Angew. Chem. Int. Ed., n/a (2019). <https://doi.org/10.1002/anie.201911609>.
- 34 [8] X. Shi, S. Siahrostami, G.-L. Li, Y. Zhang, P. Chakhranont, F. Studt, T.F. Jaramillo, X. Zheng,
35 J.K. Nørskov, Understanding activity trends in electrochemical water oxidation to form hydrogen
36 peroxide, Nat. Commun., 8 (2017) 701. <https://doi.org/10.1038/s41467-017-00585-6>.
- 37 [9] Z. Teng, W. Cai, S. Liu, C. Wang, Q. Zhang, C. Su, T. Ohno, Bandgap engineering of
38 polymetric carbon nitride copolymerized by 2,5,8-triamino-tri-s-triazine (melem) and barbituric
39 acid for efficient nonsacrificial photocatalytic H₂O₂ production, Appl. Catal. B: Environ., 271
40 (2020) 118917. <https://doi.org/10.1016/j.apcatb.2020.118917>.

- 1 [10] Y. Shiraishi, S. Kanazawa, Y. Kofuji, H. Sakamoto, S. Ichikawa, S. Tanaka, T. Hirai,
2 Sunlight-driven hydrogen peroxide production from water and molecular oxygen by metal-free
3 photocatalysts, *Angew. Chem. Int. Ed.*, 53 (2014) 13454-13459.
4 <https://doi.org/10.1002/anie.201407938>.
- 5 [11] K. Fuku, K. Sayama, Efficient oxidative hydrogen peroxide production and accumulation in
6 photoelectrochemical water splitting using a tungsten trioxide/bismuth vanadate photoanode,
7 *Chem. Commun.*, 52 (2016) 5406-5409. <https://doi.org/10.1039/C6CC01605G>.
- 8 [12] J.H. Baek, T.M. Gill, H. Abroshan, S. Park, X. Shi, J. Nørskov, H.S. Jung, S. Siahrostami,
9 X. Zheng, Selective and efficient Gd-doped BiVO₄ photoanode for two-electron water oxidation
10 to H₂O₂, *ACS Energy Lett.*, 4 (2019) 720-728. <https://doi.org/10.1021/acsenergylett.9b00277>.
- 11 [13] C. Chu, Q. Zhu, Z. Pan, S. Gupta, D. Huang, Y. Du, S. Weon, Y. Wu, C. Muhich, E. Stavitski,
12 K. Domen, J.-H. Kim, Spatially separating redox centers on 2D carbon nitride with cobalt single
13 atom for photocatalytic H₂O₂ production, *PNAS*, 117 (2020) 6376-6382.
14 <https://doi.org/10.1073/pnas.1913403117>.
- 15 [14] W. Fan, B. Zhang, X. Wang, W. Ma, D. Li, Z. Wang, M. Dupuis, J. Shi, S. Liao, C. Li,
16 Efficient hydrogen peroxide synthesis by metal-free polyterthiophene via photoelectrocatalytic
17 dioxygen reduction, *Energy Environ. Sci.*, 13 (2020) 238-245.
18 <https://doi.org/10.1039/C9EE02247C>.
- 19 [15] M. Jakešová, D.H. Apaydin, M. Sytnyk, K. Oppelt, W. Heiss, N.S. Sariciftci, E.D. Glowacki,
20 Hydrogen-bonded organic semiconductors as stable photoelectrocatalysts for efficient
21 hydrogen peroxide photosynthesis, *Adv. Funct. Mater.*, 26 (2016) 5248-5254.
22 <https://doi.org/10.1002/adfm.201601946>.
- 23 [16] Y. Shiraishi, T. Takii, T. Hagi, S. Mori, Y. Kofuji, Y. Kitagawa, S. Tanaka, S. Ichikawa, T. Hirai,
24 Resorcinol–formaldehyde resins as metal-free semiconductor photocatalysts for solar-to-
25 hydrogen peroxide energy conversion, *Nat. Mater.*, 18 (2019) 985-993.
26 <https://doi.org/10.1038/s41563-019-0398-0>.
- 27 [17] Z. Wei, M. Liu, Z. Zhang, W. Yao, H. Tan, Y. Zhu, Efficient visible-light-driven selective
28 oxygen reduction to hydrogen peroxide by oxygen-enriched graphitic carbon nitride polymers,
29 *Energy Environ. Sci.*, 11 (2018) 2581-2589. <https://doi.org/10.1039/C8EE01316K>.
- 30 [18] M. Teranishi, S.-i. Naya, H. Tada, In situ liquid phase synthesis of hydrogen peroxide from
31 molecular oxygen using gold nanoparticle-loaded titanium(IV) dioxide photocatalyst, *J. Am.*
32 *Chem. Soc.*, 132 (2010) 7850-7851. <https://doi.org/10.1021/ja102651q>.
- 33 [19] A.J. Hoffman, E.R. Carraway, M.R. Hoffmann, Photocatalytic production of H₂O₂ and
34 organic peroxides on quantum-sized semiconductor colloids, *Environ. Sci. Technol.*, 28 (1994)
35 776-785. <https://doi.org/10.1021/es00054a006>.
- 36 [20] H.-i. Kim, O.S. Kwon, S. Kim, W. Choi, J.-H. Kim, Harnessing low energy photons (635 nm)
37 for the production of H₂O₂ using upconversion nanohybrid photocatalysts, *Energy Environ. Sci.*,
38 9 (2016) 1063-1073. <https://doi.org/10.1039/C5EE03115J>.
- 39 [21] A. Kulkarni, S. Siahrostami, A. Patel, J.K. Nørskov, Understanding catalytic activity trends
40 in the oxygen reduction reaction, *Chem. Rev.*, 118 (2018) 2302-2312.
41 <https://doi.org/10.1021/acs.chemrev.7b00488>.
- 42 [22] E. Watanabe, H. Ushiyama, K. Yamashita, Theoretical studies on the mechanism of oxygen
43 reduction reaction on clean and O-substituted Ta₃N₅(100) surfaces, *Catal. Sci. Technol.*, 5
44 (2015) 2769-2776. <https://doi.org/10.1039/C5CY00088B>.

- 1 [23] C. Chu, D. Huang, Q. Zhu, E. Stavitski, J.A. Spies, Z. Pan, J. Mao, H.L. Xin, C.A.
2 Schmuttenmaer, S. Hu, J.-H. Kim, Electronic tuning of metal nanoparticles for highly efficient
3 photocatalytic hydrogen peroxide production, *ACS Catal.*, 9 (2019) 626-631.
4 <https://doi.org/10.1021/acscatal.8b03738>.
- 5 [24] M.M. Montemore, M.A. Van Spronsen, R.J. Madix, C.M. Friend, O₂ activation by metal
6 surfaces: Implications for bonding and reactivity on heterogeneous catalysts, *Chem. Rev.*, 118
7 (2018) 2816-2862. <https://doi.org/10.1021/acs.chemrev.7b00217>.
- 8 [25] M.L. Pegis, C.F. Wise, D.J. Martin, J.M. Mayer, Oxygen reduction by homogeneous
9 molecular catalysts and electrocatalysts, *Chem. Rev.*, 118 (2018) 2340-2391.
10 <https://doi.org/10.1021/acs.chemrev.7b00542>.
- 11 [26] A. Wang, J. Li, T. Zhang, Heterogeneous single-atom catalysis, *Nat. Rev. Chem.*, 2 (2018)
12 65-81. <https://doi.org/10.1038/s41570-018-0010-1>.
- 13 [27] R. Shen, W. Chen, Q. Peng, S. Lu, L. Zheng, X. Cao, Y. Wang, W. Zhu, J. Zhang, Z. Zhuang,
14 C. Chen, D. Wang, Y. Li, High-concentration single atomic Pt sites on hollow CuS_x for selective
15 O₂ reduction to H₂O₂ in acid solution, *Chem*, 5 (2019) 2099-2110.
16 <https://doi.org/10.1016/j.chempr.2019.04.024>.
- 17 [28] S. Yang, J. Kim, Y.J. Tak, A. Soon, H. Lee, Single-atom catalyst of platinum supported on
18 titanium nitride for selective electrochemical reactions, *Angew. Chem. Int. Ed.*, 55 (2016) 2058-
19 2062. <https://doi.org/10.1002/anie.201509241>.
- 20 [29] J. Gao, H.b. Yang, X. Huang, S.-F. Hung, W. Cai, C. Jia, S. Miao, H.M. Chen, X. Yang, Y.
21 Huang, T. Zhang, B. Liu, Enabling direct H₂O₂ production in acidic media through rational design
22 of transition metal single atom catalyst, *Chem*, 6 (2020) 658-674.
23 <https://doi.org/10.1016/j.chempr.2019.12.008>.
- 24 [30] E. Jung, H. Shin, B.-H. Lee, V. Efremov, S. Lee, H.S. Lee, J. Kim, W. Hooch Antink, S. Park,
25 K.-S. Lee, S.-P. Cho, J.S. Yoo, Y.-E. Sung, T. Hyeon, Atomic-level tuning of Co–N–C catalyst
26 for high-performance electrochemical H₂O₂ production, *Nat. Mater.*, 19 (2020) 436-442.
27 <https://doi.org/10.1038/s41563-019-0571-5>.
- 28 [31] J.K. Nørskov, J. Rossmeisl, A. Logadottir, L. Lindqvist, J.R. Kitchin, T. Bligaard, H. Jónsson,
29 Origin of the overpotential for oxygen reduction at a fuel-cell cathode, *J. Phys. Chem. B*, 108
30 (2004) 17886-17892. <https://doi.org/10.1021/jp047349j>.
- 31 [32] T. Takata, K. Domen, Particulate photocatalysts for water splitting: Recent advances and
32 future prospects, *ACS Energy Lett.*, 4 (2019) 542-549.
33 <https://doi.org/10.1021/acsenergylett.8b02209>.
- 34 [33] T. Takata, J. Jiang, Y. Sakata, M. Nakabayashi, N. Shibata, V. Nandal, K. Seki, T. Hisatomi,
35 K. Domen, Photocatalytic water splitting with a quantum efficiency of almost unity, *Nature*, 581
36 (2020) 411-414. <https://doi.org/10.1038/s41586-020-2278-9>.
- 37 [34] X. Chen, H. Rui, DFT-based study of single transition metal atom doped g-C₃N₄ as
38 alternative oxygen reduction reaction catalysts, *Int. J. Hydrog. Energy*, 44 (2019) 15409-15416.
39 <https://doi.org/10.1016/j.ijhydene.2019.04.057>.
- 40 [35] Y. Nosaka, A. Nosaka, Introduction to photocatalysis: From basic science to applications,
41 (2016) ISBN: 978-971-78262-78320-78265.
- 42 [36] Y. Inoue, Photocatalytic water splitting by RuO₂-loaded metal oxides and nitrides with d⁰-
43 and d¹⁰ -related electronic configurations, *Energy Environ. Sci.*, 2 (2009) 364-386.
44 <https://doi.org/10.1039/B816677N>.

1 [37] C. Adamo, D. Jacquemin, The calculations of excited-state properties with time-dependent
2 density functional theory, *Chem. Soc. Rev.*, 42 (2013) 845-856.
3 <https://doi.org/10.1039/C2CS35394F>.

4 [38] F.K. Kessler, Y. Zheng, D. Schwarz, C. Merschjann, W. Schnick, X. Wang, M.J. Bojdys,
5 Functional carbon nitride materials — design strategies for electrochemical devices, *Nat. Rev.*
6 *Mater.*, 2 (2017) 17030. <https://doi.org/10.1038/natrevmats.2017.30>.

7 [39] W.J. Ong, L.L. Tan, Y.H. Ng, S.T. Yong, S.P. Chai, Graphitic carbon nitride (g-C₃N₄)-based
8 photocatalysts for artificial photosynthesis and environmental remediation: Are we a step closer
9 to achieving sustainability?, *Chem. Rev.*, 116 (2016) 7159-7329.
10 <https://doi.org/10.1021/acs.chemrev.6b00075>.

11 [40] B. Zhu, P. Xia, W. Ho, J. Yu, Isoelectric point and adsorption activity of porous g-C₃N₄, *Appl.*
12 *Surf. Sci.*, 344 (2015) 188-195. <https://doi.org/10.1016/j.apsusc.2015.03.086>.

13 [41] L. Zuccaro, J. Krieg, A. Desideri, K. Kern, K. Balasubramanian, Tuning the isoelectric point
14 of graphene by electrochemical functionalization, *Sci. Rep.*, 5 (2015) 11794.
15 <https://doi.org/10.1038/srep11794>.

16 [42] L. Tian, F. Chen, Multiwfn: A multifunctional wavefunction analyzer, *J. Comput. Chem.*, 33
17 (2012) 580-592. <https://doi.org/10.1002/jcc.22885>.

18 [43] S. Kraner, R. Scholz, F. Plasser, C. Koerner, K. Leo, Exciton size and binding energy
19 limitations in one-dimensional organic materials, *J. Phys. Chem.*, 143 (2015) 244905.
20 <https://doi.org/10.1063/1.4938527>.

21 [44] S. Kraner, G. Prampolini, G. Cuniberti, Exciton binding energy in molecular triads, *J. Phys.*
22 *Chem. C*, 121 (2017) 17088-17095. <https://doi.org/10.1021/acs.jpcc.7b03923>.

23 [45] X. Li, W. Bi, L. Zhang, S. Tao, W. Chu, Q. Zhang, Y. Luo, C. Wu, Y. Xie, Single-atom Pt as
24 Co-catalyst for enhanced photocatalytic H₂ evolution, *Adv. Mater.*, 28 (2016) 2427-2431.
25 <https://doi.org/10.1002/adma.201505281>.

26 [46] A.V. Naumkin, A. Kraut-Vass, S.W. Gaarenstroom, C.J. Powell, NIST X-ray Photoelectron
27 Spectroscopy Database, (2012). <http://dx.doi.org/10.18434/T4T88K>.

28 [47] V.W.-h. Lau, I. Moudrakovski, T. Botari, S. Weinberger, M.B. Mesch, V. Duppel, J. Senker,
29 V. Blum, B.V. Lotsch, Rational design of carbon nitride photocatalysts by identification of
30 cyanamide defects as catalytically relevant sites, *Nat. Comm.*, 7 (2016) 12165.
31 [10.1038/ncomms12165](https://doi.org/10.1038/ncomms12165).

32 [48] J.-L. Bredas, Mind the gap!, *Mater. Horiz.*, 1 (2014) 17-19.
33 <https://doi.org/10.1039/C3MH00098B>.

34 [49] Y. Kofuji, S. Ohkita, Y. Shiraishi, H. Sakamoto, S. Tanaka, S. Ichikawa, T. Hirai, Graphitic
35 carbon nitride doped with biphenyl diimide: Efficient photocatalyst for hydrogen peroxide
36 production from water and molecular oxygen by sunlight, *ACS Catal.*, 6 (2016) 7021-7029.
37 <https://doi.org/10.1021/acscatal.6b02367>.

38
39

1 Scheme 1:

A

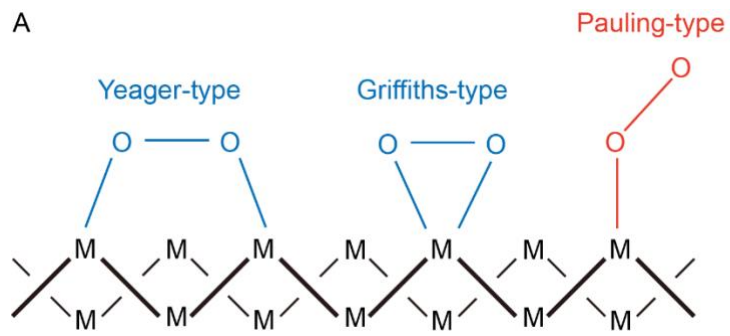

2

3

B Pauling-type

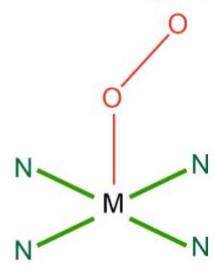

1 Figure 1:

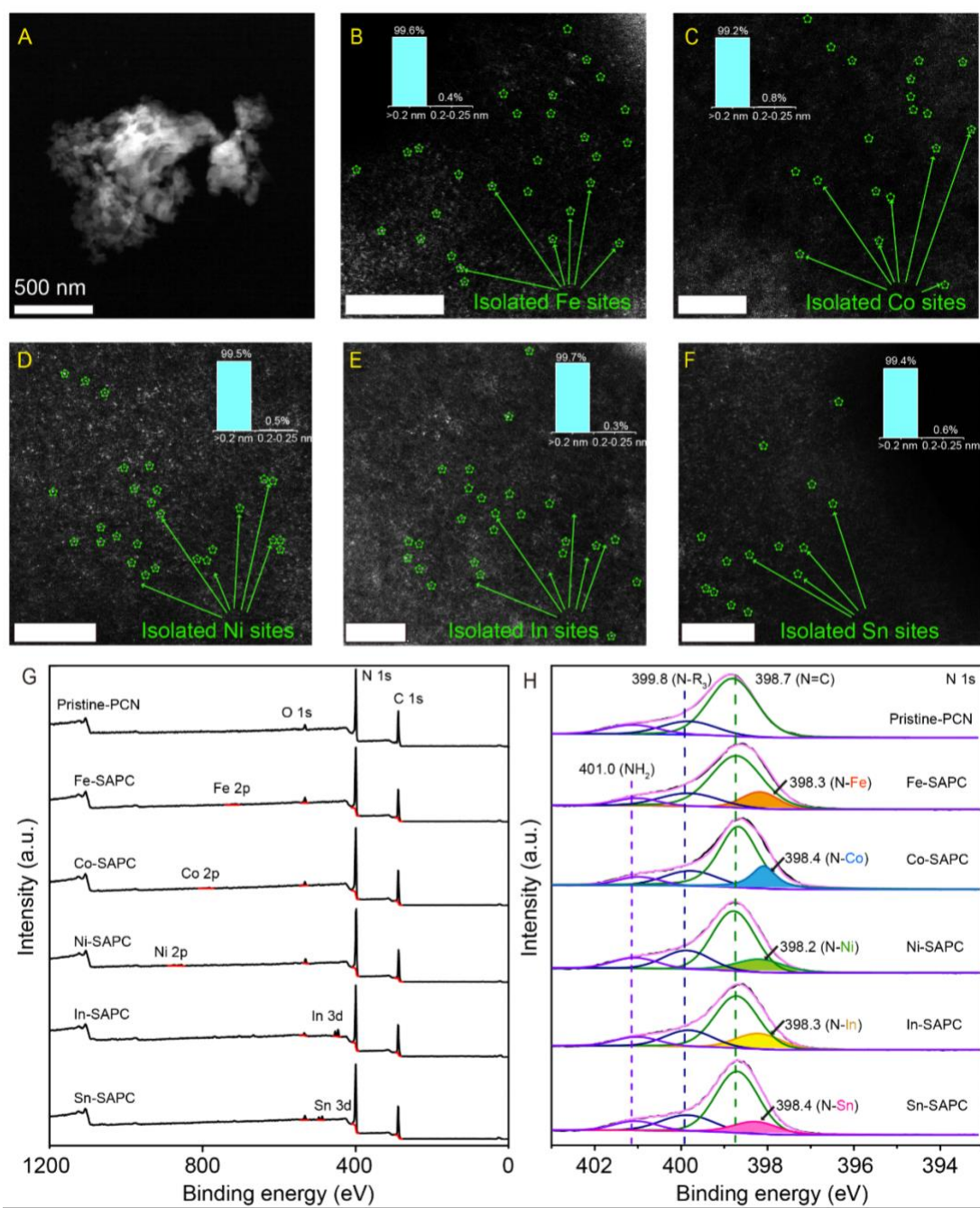

2

3

1 Figure 2:

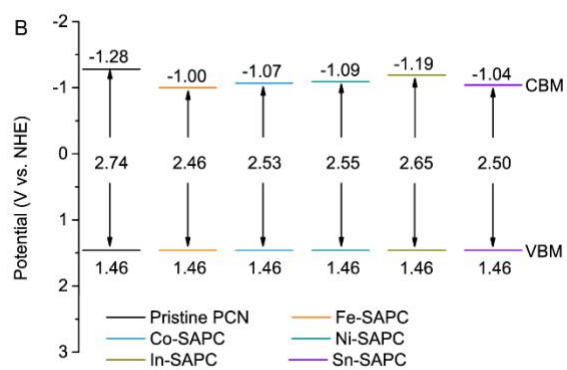
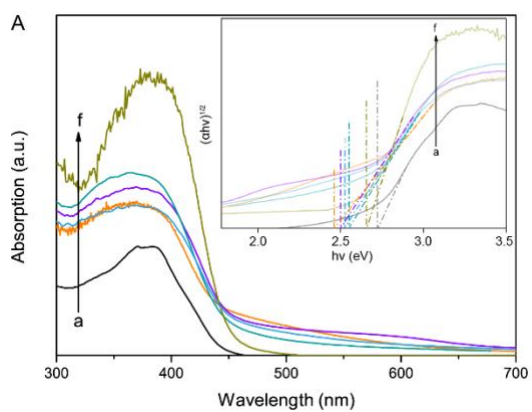

2

3

1 Figure 3:

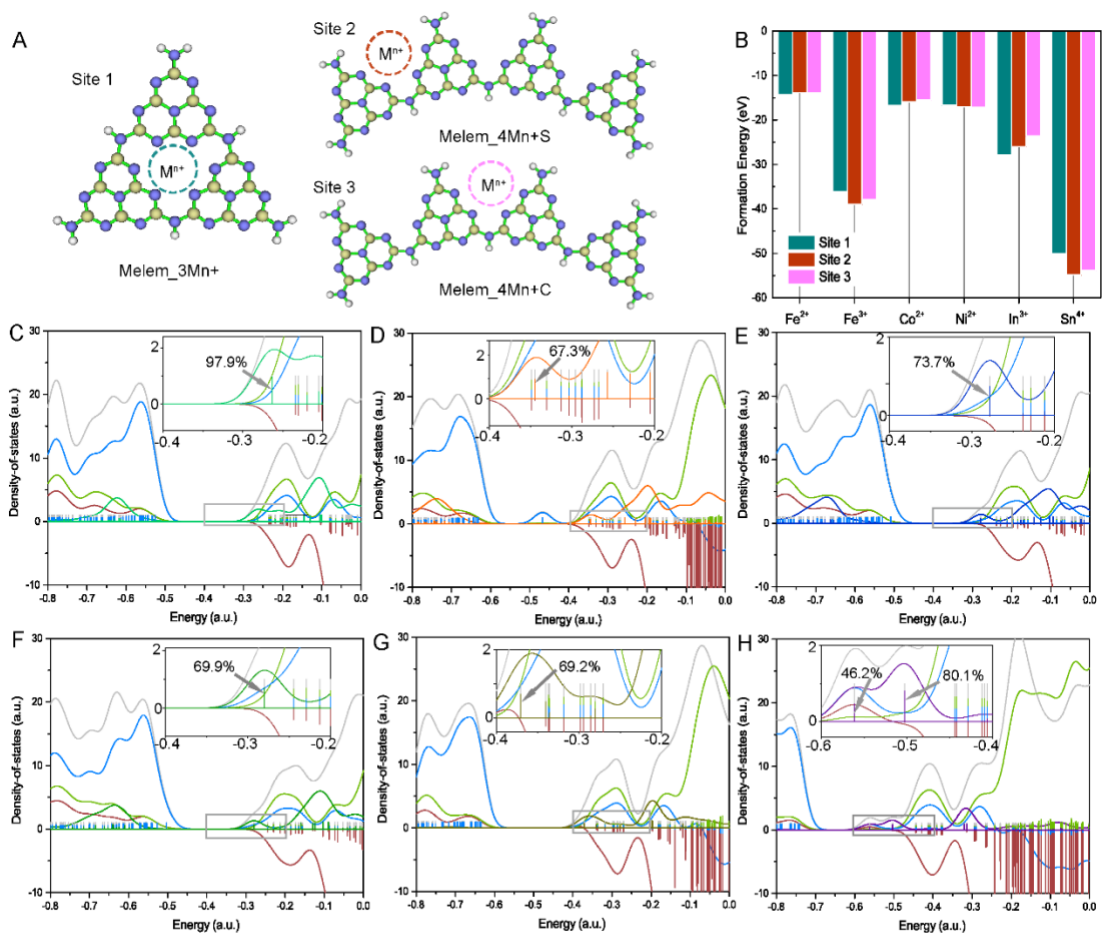

Caption for figure C-H

— Total DOS ; — Partial DOS (C) ; — Overlapped DOS ; — Partial DOS (Co²⁺) ; — Partial DOS (In³⁺)
 — Partial DOS (N) ; — Partial DOS (Fe²⁺) ; — Partial DOS (Fe³⁺) ; — Partial DOS (Ni²⁺) ; — Partial DOS (Sn⁴⁺)

2

3

1 Figure 4:

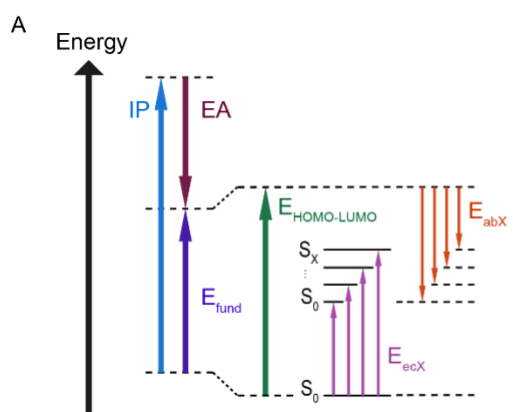

2

3

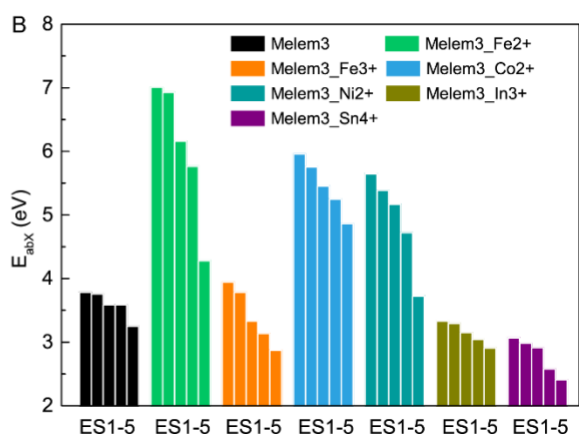

1 Figure 5:

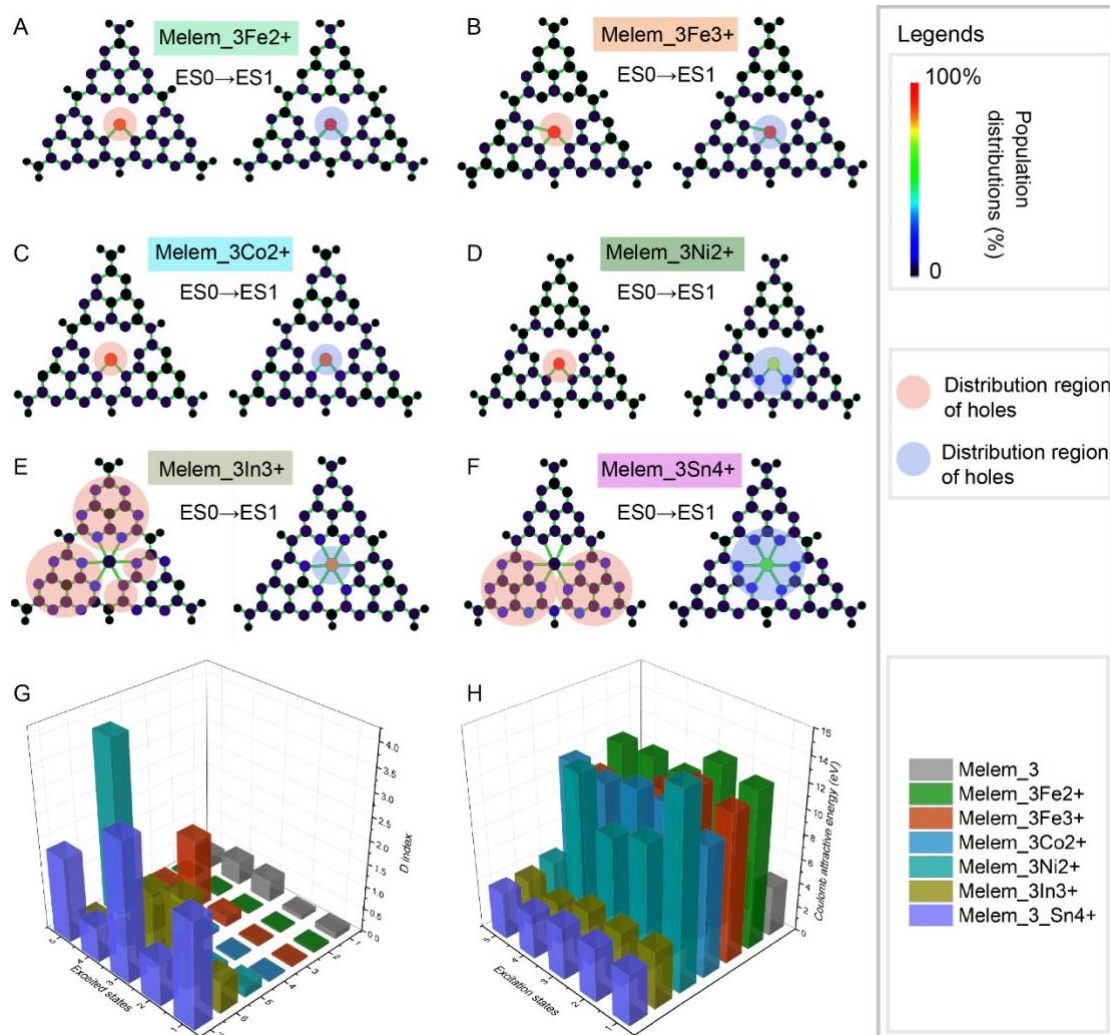

2
3

1 Figure 6:

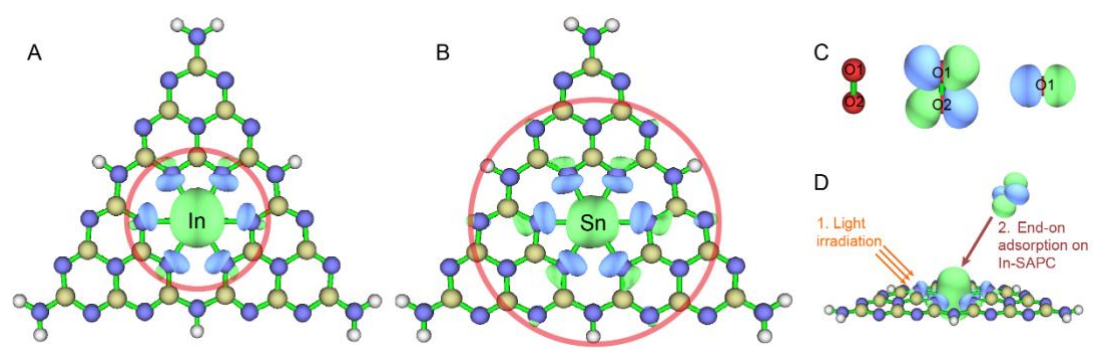

2
3

1 Figure 7:

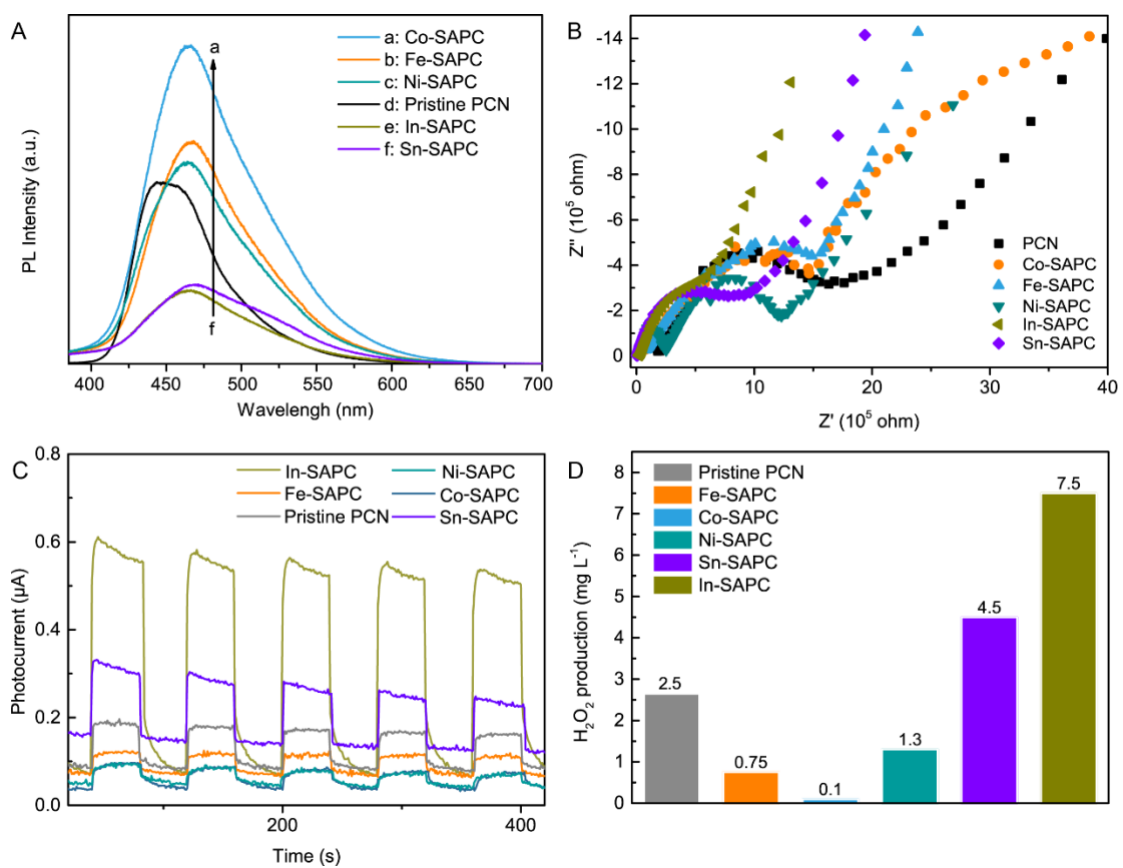

2
3
4

1 Captions

2 **Scheme 1. Adsorption types of molecular oxygen on metallic surface.** Molecular
3 oxygen adsorption on the surface of (A) metal particles and (B) single atom catalyst.

4

5 **Figure 1. Characterization of M-SAPCs.** (A) Low-magnification HAADF-STEM image of
6 pristine PCN. High-magnification HAADF-STEM images of (B) Fe-SAPC, (C) Co-SAPC,
7 (D) Ni-SAPC, (E) In-SAPC and (F) Sn-SAPC. Inset is the size distribution of the bright
8 spots. (G) XPS-survey spectra of pristine PCN and M-SAPCs. (H) High-resolution XPS N
9 1s spectra of pristine PCN and M-SAPCs.

10

11 **Figure 2.** Optical absorption and band positions of pristine PCN and M-SAPC samples. (A)
12 UV-vis spectra of pristine PCN and M-SAPC samples: absorbance spectra with inserted
13 Tauc plots. Lines a-f: a: pristine PCN; b: Fe-SAPC; c: Co-SAPC; d: Ni-SAPC; e: In-SAPC;
14 c: Sn-SAPC. (B) Band diagrams of PCN and as-prepared M-SAPC samples.

15

16 **Figure 3. Stabilities and electronic configurations of cluster models.** (A) Schematic
17 diagram for two cluster models and three possible sites for coordination of metal ions. (B)
18 Formation energies of various transition metals embedded in Melem_3 or Melem_4.
19 Computed simulation of density of states (DOS) with different embedded (C) Fe²⁺, (D) Fe³⁺,
20 (E) Co²⁺, (F) Ni²⁺, (G) In³⁺, and (H) Sn⁴⁺ with the coordination of the large nitrogen pots in
21 Melem_3. **The insert figures are amplified the states (metal) that formed the orbitals those**
22 **close to LUMO.**

23

24 **Figure 4. Approximate binding energies of Melem_3 and Melem_3M.** (A) Illustration of
25 gap energies in the molecular case: S₀ denotes the electronic ground state and S_X is the
26 No. X excited state. The S_X→S₀ energy difference then corresponds to the excitation
27 energy E_{ecX}. The magnitude of the ionization potential is shown by the blue-colored vertical
28 line and the magnitude of the electron affinity is shown by the wine-colored vertical line;
29 the IP→EA difference represents (violet line) the fundamental gap, E_{fund}, which is usually
30 smaller than the HOMO-LUMO gap, E_{HOMO-LUMO}. The approximate electron-hole pair
31 binding energy, E_{abX}, is given by E_{HOMO-LUMO} - E_{ecX}. (B) The computed approximate binding
32 energies of Melem_3 and Melem_3M for the five lowest-lying excited states.

33

34 **Figure 5. Transition densities of Melem_3M.** Population of electron and hole
35 distributions (vertical excitation at the excited state 1) and quantitative investigation of the
36 charge separation. The color in the heatmap refers to the sum of MO contribution at each
37 atom for simulated electrons and holes of (A) Melem_3Fe²⁺, (B) Melem_3Fe³⁺, (C)
38 Melem_3Co²⁺, (B) Melem_3Ni²⁺, (E) Melem_3In³⁺, and (F) Melem_3Sn⁴⁺. The orange
39 and blue shadows are accumulated regions of hole and electrons, respectively. (G) D index
40 and (H) Coulomb attraction between hole and electron of Melem_3 and Melem_3M.

41

42 **Figure 6. Visualization of the dominant contributing molecular orbitals and transition.**
43 Visualization of the LUMOs of (A) Melem_3In³⁺ and (B) Melem_3Sn⁴⁺. Red circles refer
44 to the observable region of isosurface on Melem_3In³⁺ and Melem_3Sn⁴⁺. (C)

1 Visualization of HOMO of O₂. (D) Schematic diagram of possible O₂ adsorption
2 configuration on the Melem_3In³⁺ surface after light irradiation.

3

4 **Figure 7. Photoexcitation properties and photocatalytic activities of pristine PCN**

5 **and M-SAPCs.** (A) Photoluminescence spectra of pristine PCN and M-SAPCs under 365

6 nm excitation. (B) EIS of electrodes prepared by PCN and M-SAPCs under visible light

7 irradiation. (C) Photocurrents of electrodes prepared by PCN, PCNBA0.2 and PCNBA0.5.

8 (line a: pristine PCN; line b: PCNBA0.2; line c: PCNBA0.2Co0.5%) (D) Photocatalytic

9 activities of pristine PCN and M-SAPCs for H₂O₂ production in 10% (v/v) ethanol aqueous

10 solution.

11

12