

Trinity University

Digital Commons @ Trinity

Engineering Senior Design Reports

Engineering Science Department

5-6-2022

Monitoring and Alert System for the Mabee Organic Waste Solution Final Project Report

Conner Terry
Trinity University

Evan Sturdivant
Trinity University

Emily Rosenbaum
Trinity University

Krishnan Castillo López
Trinity University

Follow this and additional works at: https://digitalcommons.trinity.edu/engine_designreports

Repository Citation

Terry, Conner; Sturdivant, Evan; Rosenbaum, Emily; and Castillo López, Krishnan, "Monitoring and Alert System for the Mabee Organic Waste Solution Final Project Report" (2022). *Engineering Senior Design Reports*. 52.

https://digitalcommons.trinity.edu/engine_designreports/52

This Restricted Campus Only is brought to you for free and open access by the Engineering Science Department at Digital Commons @ Trinity. It has been accepted for inclusion in Engineering Senior Design Reports by an authorized administrator of Digital Commons @ Trinity. For more information, please contact jcostanz@trinity.edu.

FINAL PROJECT REPORT

Monitoring and Alert System for the Mabee Organic Waste Solution Team: Conner Terry, Evan Sturdivant, Emily Rosenbaum, and Krishnan Castillo López

Team Adviser: Dr. Emma Treadway

ENGR 4382

6 May 2022

Executive Summary

Mabee Dining Hall at Trinity University has tasked the Mabee Organic Waste Solution team with the design and implementation of an in-vessel monitoring and alert device to monitor and report on the status of compost. This device is intended to provide running updates on important parameters - temperature, relative humidity, and oxygen concentration - in order to ensure production of successful, aerobic compost. If action must be taken by Mabee employees as a result of the values of these parameters falling out of an acceptable range, our device is capable of alerting the user and providing instruction to keep the compost viable.

The project requirements state that our device must be able to monitor up to 100 pounds of food waste while mitigating additional labor and unnecessary contact with the compost. It must be durable and reliable enough to withstand a full composting cycle, and intuitive enough that a user with minimal knowledge of compost care will be able to follow the given instructions with the help of a training manual provided by the team. Design constraints include the given \$1200 budget, portability, ease of use, and the versatility to be implemented in any in-vessel composting unit supplied with ~100 lbs. of food waste daily. The design constraints are detailed in Sections 3.1-3.4. The full design requirements can be found in Sections 3.5-3.9.

Our final design consists of three main subsystems: the sensor capsule, which rests inside the compost to house and protect the sensor, the communications system which interprets sensor readings and transmits instructions via Bluetooth to the interface, and the interface which displays any necessary corrective actions that must be taken. Our team was able to complete preliminary testing to ensure that each subsystem is functional within the constraints of our project. In the future, we recommend fully testing the system by placing it within a compost vessel for a complete compost cycle. Additionally, as conditions across the compost are generally not homogenous, use of multiple sensor capsules throughout the vessel to provide a more comprehensive observation of the state of the compost may be beneficial.

The central microcontroller of the partially working prototype failed to display the data from its peripheral counterpart, but the devices were still able to communicate with each other and send the sensor data. Due to a short in the wiring, the working prototype's sensors were damaged and the microcontroller in the peripheral likely to be replaced. We are mostly confident that our current prototype meets the power requirements to last a full composting cycle with our chosen battery. The corrective actions written by our team to be prescribed by measurements of the compost conditions have demonstrably improved the state of the compost in our test environment. At the time of the presentation we intend to have resolved the hardware issues with the interface subsystem, and have a fully functional working prototype ready for delivery to our sponsor.

1. Introduction

Mabee Dining Hall previously had an in-vessel composting vessel, but it consistently became anaerobic because they were not able to monitor the temperature or humidity levels. At present, Mabee dining hall staff have no way to accurately and consistently supervise the temperature and humidity levels of an in-vessel composting system intended for future use. Another issue was the employee's lack of knowledge of the compost care. The previous composting vessel was therefore not being closely monitored, resulting in the system being decommissioned due to odor, pest, and maintenance issues. Our project aims to improve the

composting process of Mabee Dining Hall by adding monitoring and alert capabilities intended to instruct staff to perform specific actions in order to produce successful aerobic yields. Aerobic composting means having compost that has optimal oxygen content for decomposition. When compost goes anaerobic, it is fueled by bacteria and can spread pathogens, and gives off a putrid odor that makes it undesirable to be in close contact with.

Last year's composting senior design team was tasked with creating a sustainable method to dispose of food waste from the dining hall. They focused on researching the best solution that would be appropriate for composting at Mabee Dining Hall, and selected aerobic in-vessel composting. That team created a small-scale prototype of a composting vessel that is limited in scalability, because the team was unable to fully test their design. This year, the scope of the project was focused on the monitoring and alert system component to ensure that a full-scale in-vessel composting process can be implemented successfully at Mabee in the future.

The overall project objective is to implement a monitor and alert system for a composting unit that utilizes organic waste from Mabee Dining Hall. It should successfully deliver information, such as compost vitals, as well as instructions to keep the compost viable in a way that is easily understood. The device should also be compatible with any composting unit and be able to sample throughout the compost. The constraints for this project dictate that: the final prototype must be portable, able to sustain power for 30 days, easy to use by someone with limited knowledge of composting, and able to be constructed and tested for under \$1,200.

The project requirements, as agreed upon by our sponsor, state that the solution must be able to be used when composting up to 100 pounds of food waste daily while mitigating additional labor and unnecessary contact with compost. It must be durable and reliable enough to last through multiple composting cycles while delivering accurate measurements the entire time, and include a training manual that instructs the user on how to care for compost with commands that are easy to understand by someone with limited composting knowledge. The sensors and probes must take measurements with adequate precision and accuracy to ensure a proper diagnosis has been performed to keep the compost aerobic.

Effectively monitoring a composting cycle means ensuring the composting process remains aerobic, as dictated by our project sponsor. As such, any solution must adhere to Code 317 of the United States Department of Agriculture's Conservation Practice Standard for Composting Facilities [31]. This code specifies that to effectively monitor compost, detailed documentation must be maintained concerning the compost's moisture level and temperature. Other parameters are specified that govern some of the crucial diagnostic parameters of the compost, such as C:N ratio and compost composition. While we make suggestions about the C:N ratio in our manual, ensuring that the ratio is maintained is out of the scope of our monitoring device.

To comprehensively monitor the composting cycle, this project will require the use of electronic enclosures that are capable of operating in the wet and bacteria-laden environment found inside the compost. Given this requirement, it is important that any solution adheres to the IEC 60529 code, which rates the resistance of electronic enclosures against the intrusion of dust and liquids [32]. Our enclosure is designed to function long-term, so the inner membrane of our design that contains the Arduino and battery must adequately protect the electronics. We do not have the credentials to assign a standard rating. However, our design does not completely adhere to this code due to the semi-permeable membrane that must allow the sensor's contact with the compost environment in order to take readings.

Our design includes a sensor capsule that will be placed into the compost and take and

interpret measurements of temperature, oxygen, and humidity. The communications system will transmit this information via Bluetooth to the interface, which will display the corrective action necessary to keep the compost aerobic. In order to meet the requirements for portability and durability, our sensors are encased in a 6” PVC pipe capped at the ends. Three acrylic membrane disks fixed on the openings at either end of the pipe protect the enclosure from the compost environment, with outlets cut out for the temperature-humidity and oxygen sensors. We purchased a battery with the necessary capacity to meet the requirement of lasting a full 30 day composting cycle based on current draw tests. We chose to implement a Bluetooth communication protocol to transmit data to the interface, which features an LCD screen to display instructions that are easy to read and understand.

2. Overview of Final Design

Our design is broken up into three different subsystems: sensor capsule, interface, and communication. A broad graphical overview of how the subsystems interact is shown in Figure 1.

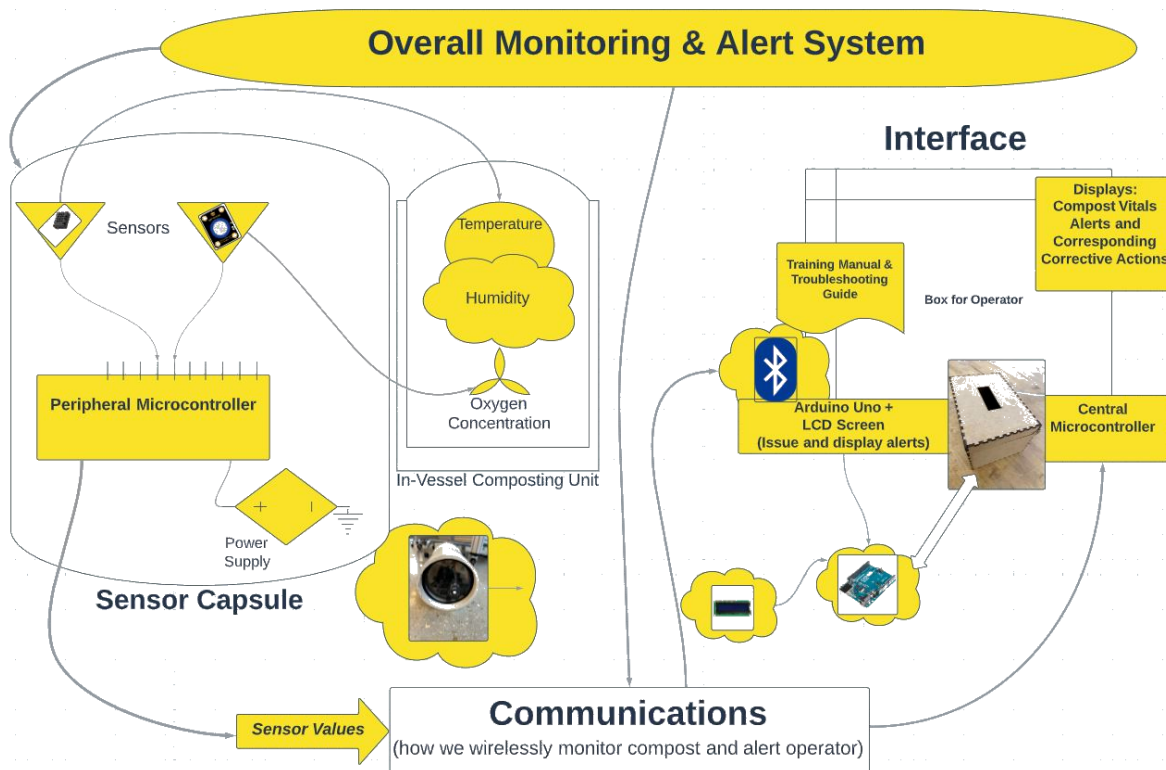

Figure 1. Schematic overview of each subsystem and how they interact with each other based on our design to achieve the overall goal of monitoring compost.

Each subsystem is necessary to achieve the desired functionality of the overall monitoring and alert system that we have designed. A sensor capsule, in the form of a self-contained, free standing probe, is intended to be easily placed in and removed from the compost vessel to record compost parameters of temperature, humidity, and oxygen concentration. The capsule encases an Arduino and sensors that perform these readings. The free standing probe will house all of the electronics, battery, and sensors that will be taking the measurements. It will be free standing so that it can move throughout the compost and take various measurements. This batch of electronics that rests inside the compost is referred to as the peripheral unit. Once values are recorded, the peripheral Arduino is designed to relay the sensor readings to a second Arduino via Bluetooth, known as the central unit, which processes the values. The operator is intended to carry this central unit out to the composting vessel each time they need to check the compost (daily); a display on the unit will report the sensor values it receives and the corresponding compost maintenance instructions to a user interface to keep the compost from becoming anaerobic.

In this section, we break down the aspects of each subsystem and expand on their features. Our design has undergone significant evolution since we decided on the direction of our design after brainstorming and critically reviewing the design throughout the year, and the project has seen fundamental changes since the preliminary design report, which is also discussed in an accompanying section below. Alongside developing our design and conducting testing, several important discoveries have been made from research that have guided the direction of our project. Our team has studied the theory of maintaining aerobic compost closely and has developed an extensive basis of knowledge on some of the key components of our project e.g. BLE communication protocol, which has adjusted our approach towards the project. These changes, improvements, and relevant theory that have guided our decisions are also detailed in the following overview section. Additionally, we document the construction techniques and tools required to achieve our final prototype.

2.1 Communication

The communication subsystem encapsulates how the microcontrollers will be wirelessly connected so that they can record compost parameters within the vessel and transmit the data to another Bluetooth equipped microcontroller handled by the operator that is assigned to tend to the compost. We chose to make use of the Arduino Nano BLE 33's Bluetooth Low Energy (BLE) communication protocol since it is optimized for low power use at low data rates, both desirable aspects for our design [15]. This protocol is targeted towards applications that may need to run on batteries for longer periods of time (months and even years). The benefits of this protocol compared to other viable options include quicker connections than standard Bluetooth, lower power consumption even when compared to other low power technologies, no cost to access official specification documents, common usage for sensor data or other repetitive tasks, and broad implementation [16]. The main limitation of BLE is its range, which was a concern for this project since a key design requirement is that the operator should not have to be in close contact with the compost in order to take measurements of compost parameters, and several obstacles provide barriers for the signal to travel through in a composting environment. However, research suggests that a range up to 3 meters is achievable, even with barriers to the signal, and our testing of connectivity strength values at ranges have indicated consistent connection ranges of roughly 2 meters, suggesting that this protocol will provide just enough

range for usage in our project that is inherently short range (more detail on this testing follows in later sections of the report). The composting vessel will be sealed for about half of the time the system is being used to monitor the compost cycles, and an operator will have to approach the vessel with the device for compost care anyways, so this protocol was determined to be most appropriate for this subsystem.

In order to program our chosen Nano BLE 33 boards used in this project, we referenced guides on how to get started with the Arduino Nano BLE 33, and heavily referenced the open source Arduino library discussing connecting Nano 33 BLE Devices [2-3]. Research was also devoted to understanding the documentation, standards, and syntax of this protocol strewn throughout the ArduinoBLE library [15]. Common nomenclature in this library is important to understand, as it will be used throughout this report to refer to the different parts of our system. The roles of two devices connected with BLE are the central and peripheral. When a BLE connection is established between two Nano BLE 33 units, one device, known as the peripheral, will advertise or broadcast information to nearby devices. Meanwhile, the central device performs a scan and listens for any devices that are broadcasting information. Once the central device recognizes the advertised information from the peripheral device, it attempts to connect to the device [3]. Once a connection is established, the central device can interact with the available information the peripheral device has, which in our case, is the sensor values from the device inside the composting vessel. Thus, for the remainder of this report, the Arduino Nano BLE 33, along with the sensors and other electronics that are encased inside a free standing probe as part of the sensor capsule subsystem, will be referred to as the peripheral device, and the Nano BLE 33 held outside of the compost vessel that connects with the interface and displays the sensor values along with necessary compost care instructions, as part of the interface subsystem, will be referred to as the central device. The peripheral unit will remain in a low-power state until the central device is brought into range. The peripheral unit will remain in a low-power state until the central device is brought into range. The process of the intended data flow of our software is graphically outlined in Appendix M.

2.2 Sensor Capsule

The sensor capsule subsystem refers to the means by which we contain and protect the sensors and other peripheral electronics to take measurements of necessary compost parameters in the hot, humid, bacteria and particulate laden compost environment. One critical aspect is the physical casing of our free standing probe that is placed within the composting vessel. The casing consists primarily of a 6” PVC pipe with two end caps on either side. The leftmost end cap is glued to the capsule’s main body to ensure the left side is waterproof. The other end cap can be removed to grant access to the interior of the capsule. Details are highlighted in the CAD model shown below, Figure 2. A CAD drawing with section analysis and labeled parts can be viewed in Appendix C as Figure C1.

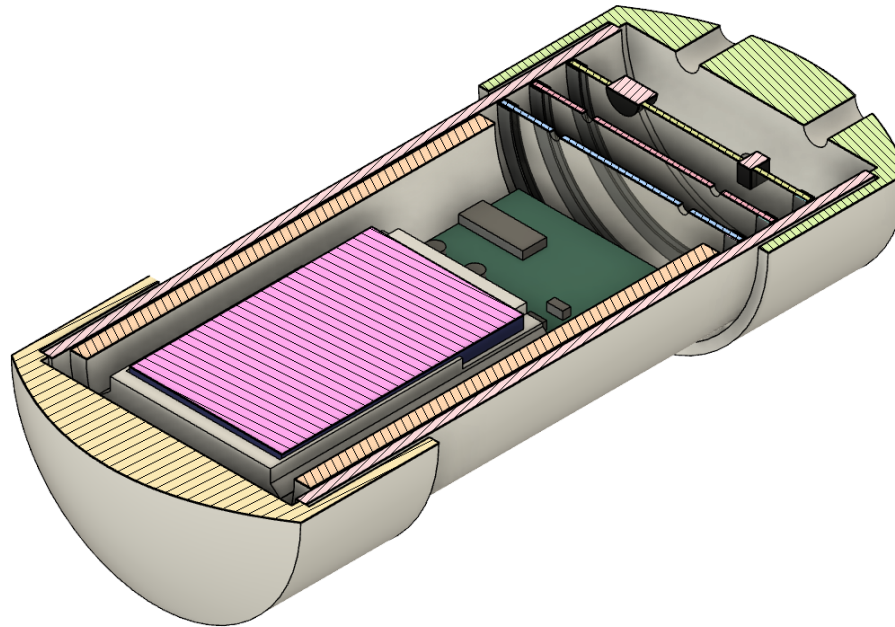

Figure 2 . CAD model of Sensor Capsule made with Fusion 360 displaying section analysis highlighting internal assembly and overall form.

The sensor capsule's primary job is to protect the sensitive electronics contained within from the compost environment, as well as any physical trauma that the capsule may experience (for example, from an auger or shovel when the compost is mixed). As such, the material that forms the capsule must be non-porous (i.e., liquid cannot seep through the material) and resilient enough to withstand impacts from mixing tools such as a shovel. The design of the capsule must also be waterproof while still granting access to its interior for maintenance purposes. Additionally, the capsule must allow the sensors access to the compost environment for measurements without compromising the waterproofing requirement.

The sensor capsule contains all the necessary electronics and mechanical components to ensure our solution is capable of providing consistent updates on compost status. The capsule surrounds an internal membrane that contains the peripheral electronics, battery, and power components, all securely held by a 3D-printed case. In the figure below, this part of the capsule can be seen to the right of the leftmost end cap; the purple rectangle (the battery which has been "sliced" by Fusion 360's section analysis) followed by the green and black circuit board, are all held in place by a 3D printed case which hugs the sides of the main body. The capsule also holds an oxygen and a joint temperature-humidity sensor, both mounted on laser-cut acrylic disks that provide the sensors with access to the compost environment while protecting the rest of the electronics. This part can be seen in the CAD model as the three disks that are positioned close to the rightmost end cap. These black parts on the perimeter of these disks act as sealants that improve the waterproofing provided by the disks. Finally, the two sensors can be seen in the disk closest to the right end cap, as that is where the sensors can gain access to the compost environment, which is provided by the four holes drilled into the right end cap.

It is important to note that there have been significant changes to the Sensor Capsule subsystem since the Preliminary Design Report (PDR). Most prominently, the capsule's material is now PVC, which differs from the recommendations of aluminum or HDPE that came from the

PDR. Last semester, the team had conducted research on suitable materials, including 3D-printed materials like Onyx [33] as well as aluminum and HDPE. We had concluded that 3D printing did not provide the necessary protection against moisture, and were leaning towards construction from machined aluminum or HDPE. However, following the PDR, we considered the cost and ease of assembly, and concluded that PVC was an easier alternative to work with, while still providing the necessary strength and protection against moisture. This conclusion came about as a result of the widespread availability and use of PVC pipes in applications involving water and humid environments, as well as high amounts of pressure. As such, we concluded that PVC was an adequate material for the sensor capsule.

2.2.1 Sensors and Electronics within the Sensor Capsule

Another inherent part of the sensor capsule subsystem are our chosen sensors, which measure the compost parameters of temperature, humidity, and oxygen concentration. These have been deemed the most important characteristics we can measure, considering the findings of last year's team and our own research into the troubleshooting techniques for rectifying anaerobic conditions [17]. Both sensors protrude from thin openings within the sensor capsule, and as such are detailed as part of this subsystem overview.

The sensors and electronics used in the final iteration of the peripheral unit include: a DHT20 temperature and relative humidity sensor, a DFRobot Gravity I^2C Oxygen sensor, and some basic capacitors, resistors, jumper wires, and headers for electrical connections. These components are centered around the Arduino Nano BLE 33, which makes use of an NRF52840 microcontroller, and features its namesake built-in BLE communication protocol. The components were soldered onto a perforated circuit board because it was readily available in the electronics shop, allowing us to secure the electrical connections, which is crucial since the device will be frequently turned and jostled once it is placed inside of the compost vessel. A perf board layout of our peripheral unit is found in, along with a wiring schematic detailing connections in Appendix J.

The electronic components were chosen based on their stated ability to withstand extended exposure to the harsh compost environment, their compatibility with the Nano BLE 33 board's 3.3V operating voltage, low power consumption, low cost, Arduino compatibility, and precision and accuracy. Inside the composting vessel, temperatures typically fluctuate between 90°F up to 140°F, but can become as high as 160°F during the thermophilic period of decomposition [1]. Optimal ranges, including 40-60% humidity, are further detailed in the following section. Temperatures above the upper optimal limit are indicative of anaerobic microorganism breakdown, and it is crucial we are able to detect these conditions. From its datasheet, the DHT20 sensor has an upper extended operating temperature limit of 176°F, a typical supply voltage of 3.3V, and features “excellent long-term stability” in a normal operating range of 40-60% humidity [7].

The DHT family was deemed appropriate for our compost monitoring process for its wide use in data logging operations due to its reliability, low power consumption, and relatively low cost of around \$5 per sensor [7-8]. Unfortunately, research suggested that only two Arduino-compatible oxygen concentration sensors exist, and only the team's chosen sensor was available for purchase, so options were severely limited. One favorable aspect of the team's chosen oxygen sensor is its suitable operating humidity range; it is stable up to 99% relative humidity [9]. Additionally, the oxygen sensor appeared to exhibit more consistent behavior when

supplied with 3.3V rather than 5V. We are most concerned when the oxygen concentration falls between 5-10%, a definitive indicator of anaerobic compost, and this sensor could suitably measure between 0-25% oxygen per unit volume of air [9, 20]. Because the oxygen sensor has upper operating temperature range of 122°F, the team is heavily relying on the assumption that prolonged exposure to temperatures above this range will not quickly degrade the sensor. Limited options for this sensor also required the team to work around the specification that the oxygen sensor must not be subject to excessive impact or vibration. Inside an in-vessel composting system, a mixing component stirs the compost to aerate it, and the functionality of this sensor might be disabled if it is struck directly, or pinched in the turning process. The sensor naturally cannot have its air intake blocked, so we were not able to directly encase the sensor to comprehensively protect it from any such damage.

2.2.2 Power Supply for Peripheral Microcontroller and Sensors

The electronics inside the capsule are powered by a 12V 10Ah lithium car battery with F2 terminal clips in order to run wires into the voltage input port of the Arduino and ground. In order to step down the voltage so that the battery can be used to power the system, an adjustable waterproof XWST DC-DC 12V to 5V buck converter was wired between the microcontroller power supply and the battery. A rough idea of this power system after it was soldered together can be viewed below in Figure C9.

At the output of this buck converter, the voltage is stepped down so that we are not supplying the Arduino with a voltage or amperage that will cause it harm and disable its functionality. The buck converter also provides >93% conversion efficiency, over-current, over-voltage, over-heat, short-circuit, anti-shock, and anti-dust protection in addition to being a proven IP67 waterproof aspect of the design [6]. Because we are not making use of the 5V pin of the peripheral Arduino to supply the positive voltage rails of the perf board, an additional step down of the ~5V supply voltage to 3.3V is performed by the internal regulators of the Nano BLE 33. This was important because our chosen sensors and other electrical components worked most reliably at this lower end of microcontroller operating voltages. Lastly, a proprietary Dakota Lithium charger and clips are included as part of the design so that the battery can be charged between compost cycles. Research indicated that Lithium rechargeable batteries are the most sustainable and reliable way to power our system for the duration of a composting cycle. We chose to focus on Dakota Lithium batteries because of their proven performance and durability, and in large part thanks to advice received from Mark Carpenter, the Trinity Electronics Technician, for recommending them as a reliable way to power our device for a long period of time. Other favorable aspects of Dakota Lithium batteries, compared to SLA equivalents that could also meet the capacity requirements, include their steady power output as the battery discharges, and longer lifespan, especially at a discharge current of 1A that aligns with the operating current of the buck converter [21].

2.3 Interface

The interface subsystem consists of a 16x2 LCD screen that acts as a user interface, capable of displaying compost maintenance instructions up to 32 characters long. It is mounted within a plywood box that, when in proximity to the compost vessel, alerts the peripheral device via Bluetooth to switch out of its idle state and begin transmitting sensor data. A central

microcontroller attached to a secondary microcontroller controlling the LCD interprets this data and determines the instructions to be displayed to the user. Our project sponsor has provided us with resources, including [1] and [4], to serve as a background for our knowledge of compost care. Throughout the year, a 37 gallon composting vessel has served as our test environment, allowing us to experimentally assess the effects of our prescribed corrective actions on the state of the compost and giving us confidence that common problems can be remedied as a result of following our instructions. A complete list of care instructions is listed in Appendix A. A flowchart detailing the code logic responsible for determining instructions to be displayed can be seen in Appendix B.

Optimal ranges of the parameters which the logic is responsible for maintaining can be seen in Table 1. It is important to note that the temperature range is the optimal thermophilic breakdown region, but healthy compost, in general, can vary between 90°F to 140°F. If the parameters fall outside of these ranges, the compost risks becoming anaerobic.

Table 1. Optimal ranges for the compost parameters [1]

Parameter	Optimal Range
Temperature	135-160°F
Oxygen Content	> 10%
Moisture Content	40-60%

Research from last year’s team also helped us determine the optimal ranges for keeping the compost aerobic, as well as recommendations for when problems arose. For example, according to their research, the best bulking agents to reduce moisture were wood chips and hay. They also determined an optimal composting ratio of 4:2:1 (organic waste, hay, wood chips). It is important to note that they tested their compost in 6 gallon buckets.

2.3.1 External Electronics

The electrical components of the interface unit are centered around a central Arduino Nano BLE 33 that receives the sensor data from the peripheral, and an LCD screen serving as a user interface. Since the Nano BLE 33 was not compatible with the LCD screen, an additional auxiliary Arduino Uno is used to drive the display, and communicate with the central Nano via the serial ports of each Arduino. A better idea of what the system looks like from the outside is shown in Appendix _.

An Uno is responsible for processing and displaying relevant compost parameters and care instructions onto a user interface, as the Nano BLE 33 was found to be unsuitable for these purposes due to its lower supply voltage. Instead, a Nano BLE 33 serves as a central BLE device, scanning for BLE characteristics from the peripheral device which reads sensor data, and relays the raw data to the Uno. Arduino LCD libraries are more readily supported and easy to use with the Uno, so we did not have to perform any special modifications to the basic Arduino LCD library as we had previously planned.

2.3.2 Power Supply for Central Microcontroller and User Interface

The central Nano BLE unit differs from the peripheral in that its 5V pin is activated by a soldered short circuit on its 3.3V pad and is powered directly by a micro-usb cable. We originally intended to power the LCD, which relies on a 5V power supply, using this microcontroller, but in the final iteration of our central device, the operating voltage requirements are fulfilled with an Arduino Uno.

The central system receives power from an Anker PowerCore Select 20000mAh bank with two output ports, capable of powering both the Arduino Uno and Arduino Nano BLE, with the microcontrollers sharing power. The Nano BLE 33 receives direct USB power and relays power to the Uno from the 5V pin. This type of power bank is widely used for cell phone charging, and is intended to be recharged regularly. A benefit is the relatively large-capacity, making it a reliable option to supply our chosen microcontrollers with consistent power. Additionally, since the central device is intended to be handled frequently by Mabee employees, it was beneficial that this type of power bank is a relatively familiar device that is easy to handle.

2.4 Relevant Research & Theory

Other supporting research that has guided the development of our project but was not mentioned in any of the prior subsystem subsections is included here. These sources offered inspiration and helped justify our design decisions for each of the subsystems, as well as the overall design.

A significant portion of the research that has guided the development of our project involves other microcontroller-based remote sensing projects, particularly systems that are designed to operate in harsh environments. Similar projects referenced include the Cave Pearl Data Logger Arduino-Based logging platform, which included helpful details for comparison to our design such as a breakdown of the power requirements for the system, waterproofing aspects of a PVC capsule that protects the components, and a data flow diagram [14]. Another generic system designed to remotely monitor key environmental parameters gave us inspiration on power saving measures, data transmission, and data display, and offered examples of mounting and weather resistant casing that were applicable for our system. Importantly, this source advised that we could not wire a car battery directly with the Arduino without quickly burning it up [28]. We learned more about the proper procedures to accurately measure the current consumption of our project, from a tutorial for the power consumption of a similar Arduino environmental sensing project [37].

We compared various microcontroller options that were suitable to base our sensors around throughout the entirety of our project, until we had fully committed with the Nano BLE 33. Other options that could have feasibly achieved similar remote sensing capabilities included the Raspberry Pi 2, Adafruit FeatherLoggers, and ESP8266 development board with NodeMCU8266 [25-27]. Although many of these microcontrollers have improved features when compared to the Nano BLE 33, they were rendered infeasible by the triple constraint of time, budget and scope.

We performed research on compatible joint temperature-humidity sensor options once we had selected the Nano BLE 33. A helpful source when comparing options was [29]. Further information from this source confirmed that we needed to engineer a way to keep the sensors as dry and secure as possible. The DHT22, used in the first rounds of sensor testing, was found to perform unreliably at a supply voltage of 3.3V. By comparison, the DHT20 has an operating voltage range of 2.2-5.5V and is capable of more accurate, precise measurements [8], which

makes it more suitable for our applications as the temperature inside the compost is not homogenous throughout the vessel [22].

Looking into the best way to step down the voltage of our chosen car battery found that DC-DC buck converters are generally more energy efficient when compared to the linear voltage regulators that were present in previous iterations of the prototype.

Research also suggests that most compost issues arise when it is out of balance. We have utilized recommendations on the proper steps to start an in-vessel composting process so that we could create a simulated testing environment for our design [34-35]. This smaller vessel can be seen in Appendix E. Our vessel was not able to reach the thermophilic stage during which we are most confident that our device will function appropriately, since the minimum size at which compost will heat up to desired temperatures is 3' x 3' [34]. However, issuing our own corrective actions to this compost throughout the year gave us experimental evidence for the validity of each of the care instructions we include as part of this final design. We observed correlations between some of the actions administered to the compost and the ensuing results that aligned with theory. For future work we would recommend more comprehensive monitoring of the compost to verify these findings. Our current understanding of compost care is mainly guided by external sources, but we were able to confirm that aerating, adding bulking agent, and adding more food waste to the pile produced outcomes that aligned with the research. A main finding from our research was the sheer amount of factors that can contribute to compost becoming anaerobic, meaning that the scope of our device alone is not enough to completely prevent this scenario. We include as much background information as possible that might be helpful in this process, but no matter what, this research suggests that our compost monitoring and alert system alone cannot feasibly prevent or resolve every possible case leading to anaerobic compost. Attention will need to be paid to the sources we referenced for background information for a future composting operation to remain successful [1,4,17-20,34-35].

To determine the best measure of signal strength for our BLE testing, we developed an understanding of received signal strength indicator (RSSI) versus dBm readings, both of which represent signal strength and are both expressed in the same units of dBm. We decided that RSSI would be the most suitable measure of signal strength, as it is a relative index that accounts for factors that influence radio waves such as the chipset, diffraction, and absorption and interference [36].

2.5 Changes Since Preliminary Design Report

Since the team's PDR, changes have been made to almost every aspect of the project. The features that have remained the same have undergone significant development, either in our own understanding, or their implementation alongside the rest of our design.

The team had been planning on using a joint temperature-humidity, which conveniently measures two of the key compost parameters with one sensor, and thus has seen implementation in our subsequent iterations of the prototype. However, we are no longer monitoring the pH of the compost. Although this parameter was designated by last year's team as one of the most important parameters to maintain aerobic compost, we have learned from our sponsor that it is more of an outcome than a driving factor in maintaining optimal conditions. Any issues with the compost that could be indicated by non-optimal pH are accompanied by conditions that can be measured by temperature, humidity, and oxygen concentration alone [17-18]. We therefore

decided that measuring the oxygen content, in addition to temperature and humidity, was an effective “catch-all” solution that would indicate that the compost is becoming anaerobic whenever the sensor records an oxygen concentration lower than 10% [19]. Thus, measuring this parameter was found to be more important for suggesting definitive corrective actions for maintenance, rather than measuring a symptom of anaerobic compost which is also non homogeneous and difficult to average since pH is recorded on a logarithmic scale [20].

When formulating our PDR, we had decided to supply the system with lithium polymer 7.4V battery power, and the merits of Lithium batteries have seen them utilized in different iterations of our design. We recognized that this power supply was likely unsuitable to meet the power requirements of our project, and started to explore higher capacity battery options once a better estimate of the expected system power consumption was determined from the first round of power draw testing. The higher capacity of the batteries meant that they also generally had a higher voltage, so we then explored and included onboard voltage regulators in subsequent iterations of the design. Eventually, we realized that our sensors did not require these components in order to function as long as they were compatible with the operating voltage of the board. Thus, it was clear that we would benefit in terms of both reliability and power consumption if we used a different approach to step down the voltage to assure proper functionality of the board. Other developments in our understanding of power supply for the peripheral unit have influenced design changes, including realizing that low power mode was not compatible with our original Arduino Nano board, and thus choosing to make use of the Nano BLE 33 microcontroller for both the peripheral and the central. This had a dual advantage: the BLE protocol support negated the need for an additional transceiver module that consumed significant power, and the peripheral unit could be placed in a very low power-consuming state until the central unit was brought into proximity.

We began developing the peripheral Arduino software after the PDR was modified to reflect the final version of the design. Fortunately, the Nano BLE 33 is a pin equivalent version of the original Arduino Nano, the code we had still worked once we properly configured the Nano BLE 33 in the Arduino IDE. However, this meant that we needed to revise our original design to ensure that it was 3.3V compatible [23].

We have also decided to use PVC for the sensor capsule, instead of 3D Printed Onyx material or anodized aluminum, as it was a relatively cheap and waterproof option. Onyx failed the humidity test designed to assess its viability as a sensor capsule. PVC, in turn, exhibits adequate impact durability and water resistance, as well as being cheap and easy to construct. Simulated testing of other polymers or anodized aluminum was not as heavily emphasized as the team realized that PVC was a viable option and required less machining.

Our communication subsystem was originally planned to be based around the BLE communication protocol due to its broad support and usage in familiar devices. As the project evolved, we tried using RF transceivers, featuring a similar ~2.4 GHz transmission frequency, for the purposes of final prototype sensor testing. However, we switched back and implemented BLE as the chosen communication protocol for our final design, as outlined in the PDR.

Other design considerations that have been discarded throughout the development process include an SD card that would be used to log historical values of the compost parameters, since that was once a goal of the design, and would have made the system more user-friendly for Mabee employees by allowing them to view trends. However, SD cards can draw up to 200 mA during normal operation, and minimizing the power consumption of our device was more crucial for successful operation, given that storage was never a project

requirement. The system is only designed to display data and corrective actions at the instances when an employee brings the central device up to the compost to check on it. A real time clock (RTC) module was also considered so that the system could keep track of time even if the Arduino loses power, so we could periodically signal the system to become active and take measurements. This approach was unnecessary when it was understood that the Nano BLE 33 could be placed in rest mode and woken up simply by having another Nano BLE 33 which acts as the central device coming into proximity with it. Once the central device is out of the communication range of the peripheral device, the unit within the compost goes back into rest mode.

2.6 Construction

Several different construction techniques, tools, and pieces of Makerspace equipment were used to build the final prototype. In the Makerspace we used the laser cutter in order to cut the acrylic disks for the membrane and the housing for the central Arduino and LCD screen out of 3 mm plywood. Photos of the overall assembly and various subassemblies are shown in Appendix C. We used the new Onyx 3D printing material to build the first iteration of our sensor capsule. Porosity tests on the material proved unsuccessful, which is why we decided to switch to PVC for the sensor capsule. In order to alter the 6" PVC pipe, we used a hand drill to drill the four holes onto the end cap and a bandsaw to cut the pipe into the size we needed. Lowe's only sold the PVC pipe in 10' sections, so we had to cut it down to the correct dimension, approximately 15" in length. Sections of our sensor capsule, as they were being put together, are shown in Appendix C. Photos of the construction process for the central box are not included in Appendix C, but simply relied on gluing together each side of the box.

For the electronics, electrical liquid tape was used to secure and waterproof some of the electrical connections. This glue provided a clean, safe, and simple solution to maintain waterproof electrical interconnections that can withstand up to 275°F with a negligible reduction in conductivity [10]. Examples of this protective coating used as a reliable sealant are shown in Appendix C.

We also used the soldering machine to secure our electrical connections to the perforated boards for both the peripheral and central units. The 5V pin on the central microcontroller was shorted with solder, as the Arduino Nano BLE 33 has this pin disabled by default. Before using the oxygen sensor to take measurements, it was critical to calibrate it. This was as simple as pressing a button on the module and waiting three minutes, while checking the results with a built-in example calibration program offered with the DFRobot library [9].

3. Design Evaluation

Design Constraints

3.1 Final prototype must be constructed and tested for under \$1,200

We were tasked with remaining within a \$1,200 budget as allocated by Trinity University's Engineering Sciences Department.

Evaluation

We satisfied this constraint by spending \$963.29 of the allotted \$1,200. Accounting only for the components used to build our final design, a similar system could be reproduced for \$419.91. The total cost of the central and peripheral units were \$83.33 and \$336.58, respectively. The price of plywood used to construct the box containing the central microcontroller and user interface was the only part for which we had to develop a rough estimate. Machining was performed for free in the CSI Makerspace. A complete bill of materials showcasing the part descriptions, manufacturers, and sources is available in Appendix N.

3.2 The monitor/sensor must be easy to insert into the composting vessel for someone with limited knowledge of composting

Associated Test: Ease of Use

The purpose of this test is to confirm that our device is portable and is easy to insert into a composting vessel and remove after it has been mixed for someone without knowledge of composting.

Objectives

The objective of this test is to confirm that our sensor capsule is sufficiently portable and easy to insert and remove from the compost vessel for a user without prior knowledge of use of either the capsule or compost vessel. An adjacent survey will gather information on how well the training manual and instructions can be understood.

Features Evaluated

The features that were evaluated with this test are the sensor capsule's portability and ease of use by any employee or person with limited knowledge of composting.

Test Scope and Key Test Conditions

We tested the ease of use of our device with four people that have limited knowledge of composting. They were asked to hold and move the device, place the device into our composting bin, and then retrieve the device using a shovel. This process can be seen in Appendix E. At the end of the process, they were asked to rate the ease of the tasks using the Likert scale. Each participant was told the following statement and asked to rate it based on the Likert scale: *The process of transporting, placing the sensor capsule into the compost, and taking it out of the compost was easy and I was able to do it without additional instructions.*

Pictures were only taken of the test being done with the first prototype, that is why it appears smaller than 6 in. Appendix E shows the test being done with the 4 in PVC, but since they are the same shape, we are assuming that the results would be the same for this test.

Instruments/Test Setups

For this test we used iterations of our final prototype sensor capsule and four test subjects with limited to no knowledge of composting. We created a survey in order to gauge their perceived difficulty in using our instructions to complete the task.

Assumptions

For this test, we assumed that all test subjects were able-bodied and lacked background knowledge of compost care. We also assumed that the experience of placing our device into a small composting vessel will be comparable to placing it into a larger vessel.

Acceptance Criteria

We will know that this test is successful if test subjects are able to transport the device easily and place it in the compost bin properly, and generally agree that the process is intuitive.

Test Results

The results from the Likert survey can be seen in Figure 3.

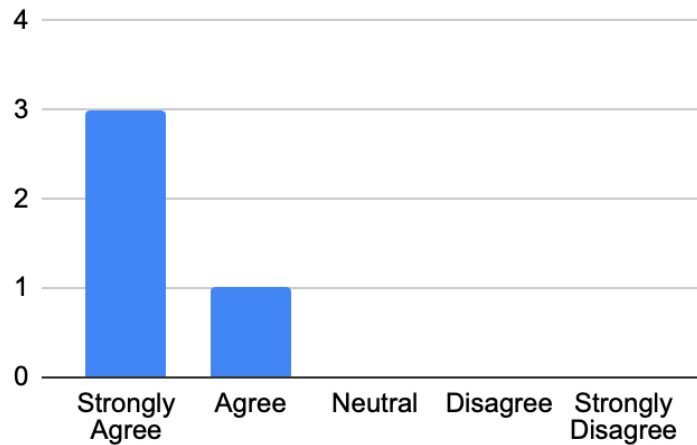

Figure 3. Likert scale survey results for the ease of use test and statement: *The process of transporting, placing the sensor capsule into the compost, and taking it out of the compost was easy and I was able to do it without additional instructions.*

Evaluation

According to Figure 3, transporting, placing the sensor capsule into the composting vessel, and taking the sensor capsule out of the composting vessel was easy to do, as everyone either agreed or strongly agreed with the statement above. The “agree” response might have to do with the fact that the subject had to get their hands dirty when taking the capsule out of the compost, which could be helped by wearing gloves or use of a shovel. Our design passed the Ease of Use test, allowing it to meet the corresponding design constraint. It is important to note that this test was performed on the first version of our prototype which used a 4” diameter PVC pipe. Our final prototype is a 6” diameter PVC pipe, which we expect will make retrieval out of the compost even easier.

3.3 The monitor/sensor must be portable

Associated Test: Ease of Use

This test was described in detail above in Section 3.2.

Acceptance Criteria

We will know that this test is successful if our test subjects are able to transport the device easily and place it in the compost bin properly.

Test Results

All 4 participants were able to move the sensor capsule into the composting vessel and retrieve it after it had been rotated. They all deemed it easy to do based on the Likert scale survey results from Section 3.2 above. They agreed or strongly agreed that the device was easy to transport.

Evaluation

Because all 4 participants were able to easily transport the device to the composting vessel and retrieve it, we deemed our device portable, satisfying the corresponding design constraint.

3.4 System must retain power for the duration of a 30 day composting cycle

Associated Test: Power Draw Test

The purpose of this test is to verify the suitability of the power system for our peripheral unit containing the sensors for the entirety of 30 days of normal functioning.

Objectives

The peripheral device must be able to retain power and remain capable of taking measurements of compost vitals for at least 30 days. This test is designed to determine the necessary specifications of the battery to supply our electronics with power for the minimum amount of time the probe would be sealed inside the compost vessel. We extrapolated the power consumption of the device over the course of a 30-day period based on power draw in the various states in which the system will operate. The goal of this test is to determine the capacity [mAh] and physical dimensions of a rechargeable battery that can supply power to the prototype for the duration of a 30 day composting cycle. Several rounds of testing have been conducted to account for the changes in the electronics used throughout the evolution of the final prototype.

Features Evaluated

The design feature that was evaluated by this test is the battery life. The Arduino must be able to take and communicate sensor measurements while sealed within a composting vessel where the battery cannot be easily recharged. Additionally, this test was useful in determining the physical dimensions for the sensor capsule before the battery was purchased. Once the team had a battery available for implementation with the final prototype, this test evaluated if the amount of discharge experienced by the battery over an extended period of time confirmed that the team's chosen battery could supply power to the system for the course of a full composting cycle.

Test Scope and Key Test Conditions

For the first round of power draw testing, the Arduinos were supplied with power through a USB adapter supplying 5 VCC. Power consumption was recorded during sleep and active states while the DHT22 temperature and humidity sensor and other electronics drew current. For the second round of testing, which more accurately reflected the electrical components used in the final design, the nominal power requirements of each component were compared with tests of onboard power draw from the Arduino Nano BLE 33 and other peripheral electronics as the device was used to record and transmit data in rest and active states, the two main operating modes of the device.

The first round of power draw testing was conducted with a peripheral unit that featured several electronics that ended up being replaced with more suitable parts for the final prototype. Current draw of the device in the active and rest states was recorded from the component datasheets and summed to determine the total nominal current draw. These results were then compared to the total current recorded in each state using an INA219 sensor integrated onto the prototype board, and to results obtained by probing the board with a digital multimeter. Total current draw in each operating mode was multiplied by the runtime of each state over the

duration of a compost cycle. The total current from both states of the device was used to determine the capacity of the battery. The INA219 module automatically recorded the power consumed during an active sensing state and when the peripheral Arduino was in the lowest power-consuming state while still being able to signal the device to take a measurement.

Instruments/Test Setups

The initial round of power consumption testing was performed with an Arduino Nano powered with a micro-USB. The breadboards and other necessary wiring (for power supply, grounding, and connections) and components (voltage regulators, resistors, capacitors, transceiver) supplied by the electronics lab were required, in addition to the sensors required for the monitoring aspect of the project. We set up the prototype to consume power by sampling the compost four times a day, the frequency we expect necessary to yield successful compost. The INA219 current sensor module and a multimeter were used to record current and determine power consumption of the device in both active and rest mode. The Arduino software was used to record values and display instructions via the serial monitor.

The second round of power draw testing was performed with the Dakota Lithium 12V 10Ah battery, an XWST DC-DC step down buck converter, Arduino Nano BLE 33, and other final peripheral electronics. Nominal current and power consumption values were taken from the respective datasheets of the DHT20 and Gravity I^2C oxygen sensor. Once again, a digital multimeter was used to probe the components to observe the current, and the INA219 sensor module was placed onto the board to give additional measurements onboard current.

The BLE Low Energy Arduino library was important for testing as it allows the board to easily be placed in an idle state until it is woken up by a central BLE device coming into proximity with the device. These were the lowest and highest current draw states in our testing

Our project does not have constant current demands since most of the time the peripheral Arduino within the sensor capsule will be stationed in rest mode - close to minimum current - followed by a significant current draw to record, communicate, and process parameters or instructions as the board is turned on and the sensors become active. We performed a series of current measurements to compute an accurate estimate of average current consumption in each state, which could then be multiplied by the rating of our battery to determine the expected runtime [11].

Other methods that were used as part of this test include extrapolating the power consumption for 30 days from measurements of shorter periods, summing the expected power draw of all the components and Arduino using datasheets, or measuring the starting and ending states of the battery. We decided to proceed with the INA219 current monitor approach as the definitive method to determine overall power consumption, since it directly interfaces with the board and has the ability to directly measure changing voltage and current, and thus power, for the first round of testing. This approach was supplemented by measuring the current directly with a digital multimeter. Both sets of experimentally obtained total current consumption values were compared with values from the component datasheets to see if the estimates are consistent. However, we focused on the results from the INA219 sensor method for initial testing since it most reliably determines the power consumed in both rest and active states. Thus, this approach requires less guesswork. Principles used to determine the power dissipated across the pullup resistors used for the I^2C ports of the board were also employed to help form nominal estimates. The technique of converting between mW and mAh was also used for the second

round of testing, since the power consumption of the resistors was easier to determine in terms of wattage, using the equation for DC power considering the square of voltage and resistance.

Current draw for the multimeter method was gathered by using an ammeter and probing each component while in the average mode, with connections to the power supply of each component in series.

Assumptions

The following assumptions were made during initial power draw testing: the capacitors in the battery would not deteriorate or significantly reduce the battery capacity over time; current draw at an ambient temperature of 77°F would reflect power consumption when inside the composting vessel at extended periods of temperatures around 100°F; battery consumption would be approximately the same each day; current consumption for the duration of a sleep state plus four active states would be an adequate sampling frequency approximating total expected power consumption; the device would only be operating in active mode (peak current consumption) for 0.27% of the full composting cycle during the first round of testing.

After realizing that the device's active time needed to be increased to give the sensors time to heat up and record accurate values, we now assume that the device will have to be active for 0.83% of total runtime, as reflected in the second round of power draw testing. In initial testing, we assumed that all low power optimizations made for the Arduino would not affect its ability to monitor the compost. These optimizations reduce the standby current of the Nano BLE 33 board to as low as 0.9mA [12]. By the final iteration of the design, it was evident that we could not make all the power optimizations we had hoped. We therefore assumed that the current consumption of the Nano BLE 33 in rest and active states is a standard 3.4mA and 19mA, respectively, even though we knew we could achieve a lower standby current [13]. We also assumed that the oxygen sensor has similar power draw requirements to that of comparable I^2C air quality sensors, since both sensor modules feature the same pinouts and operating voltages, and employ similar processes to take measurements [5]. The capacitors used were assumed to consume no power, because they nominally consume no power for the DC current considered in the calculations.

Additionally, we assumed that the battery will be adequately insulated from the hot composting environment, and that the power consumption of the device will be unaffected by its placement in a sensor capsule. The selected Dakota Lithium battery has a recommended upper operating temperature of 120°F, and prolonged exposure of lithium batteries above their recommended temperature limit can significantly reduce the expected capacity. A safety factor that was included in calculations of the necessary capacity was intended to account for any suboptimal charge-holding of the battery, but thermal effects were not our main reason for choosing to include this factor. It is good practice to derate batteries, which means we are assuming that we will only get about 75% of the ideal battery life. PVC and other pieces of the membrane in between the battery and the composting environment are assumed to be adequate for keeping the battery below this temperature. Also, in order to meet the intended sustainability objectives of the project sponsor, we are assuming that the battery is accessible within the device and can be easily replaced to allow for multiple uses of the device, and that the battery will not degrade quickly. It does not make sense for the battery to be rechargeable if it cannot be removed, charged, and used again easily within the device. Finally, we assume that only 93% of the power capacity available for the system is usable due to the nominal efficiency of the buck converter. For this reason, the final reported power capacity for the final iteration of the prototype has an additional factor of 7% added onto them.

The 25% safety factor introduced in the calculations accounts for the decreased capacity expected from a lithium polymer battery during prolonged placement inside the hot compost environment, despite the slight insulation provided by the capsule.

Not knowing the expected power supply of the oxygen sensor meant the current consumption had to be estimated in order to form an approximation of the expected nominal power consumption. Because these specifications were not available on a datasheet, the current consumption considered in testing was based on a comparable I^2C air quality sensor modules.

Acceptance Criteria

In order to meet the design requirement and be considered a successful test, the battery must be able to supply the power necessary to take measurements for the duration of the lockdown phase of the composting cycle. Current consumed will be measured and used alongside the rating of the battery to determine if the device can remain operational for 30 days. For an expected runtime of 720 hours with a safety factor of 25%, the battery must be able to power the device for at least 900 hours. The battery was only considered a success during the second round of nominal testing if it could meet the power requirements for the worst case nominal scenario.

For this scenario, we are assuming that the standby and active current of the oxygen sensor is at the listed upper limit of a comparable I^2C module: 100 mA active current and 100 μA [5].

Test Results

Results are presented in Table 2. Battery dimensions are based on the size of commercially available lithium polymer battery options that can supply the calculated capacity and feasibly work for our project.

Table 2. First round of power draw testing with full prototype - three methods with respective current consumption of modes used, and technical information of battery that can fulfill the power requirement [21]. These results were used to make a final battery selection.

	Nominal	INA219	Multimeter
Total Current Draw in Active Mode [mAh]	155	276.13	659
Total Current Draw in Rest Mode [mAh]	8808	36304	31363
Total Power Consumed [mAh]	8964	36580	32022
Battery Capacity Required [Ah]	10	40	32
Battery Dimensions	5.94" x 2.55" x 3.78"	2.59" x 6.30" x 3.63"	5.88" x 3.63" x 3.91"

The first round of power draw testing helped indicate the physical dimensions for the battery that will be housed inside the sensor capsule alongside the rest of the peripheral electronics. It was evident from these initial results that optimizations or more energy efficient components should be chosen for the next iteration of the prototype, and the team was confident in our ability to implement these changes in order to achieve closer-to-nominal results in practice. The total current draw in rest mode was the biggest area of concern, and the results were likely skewed because the device was continuing to receive current and communicate with the serial monitor of the Arduino IDE while measurements were taken.

Once the electronics part list had been updated and finalized, power draw testing was repeated before the board was soldered along with the other components and the perf board. The updated components and power supply used led to the following results in Table 3.

Table 3. Second round of power draw testing with final iteration of prototype powered with 12V 10Ah Dakota Lithium Battery stepped down to 5V supply with buck converter - three methods with respective current consumption of modes used, and technical information of battery that can fulfill the power requirement [21, 38]. A best case nominal scenario is included for reference.

	Nominal Best Case	Nominal Worst Case	Multimeter
Total Current Draw in Active Mode [mAh]	352.31	914.81	29.09
Total Current Draw in Rest Mode [mAh]	5301.45	5435.33	3461.78
Total Power Consumed [mAh]	6049.53	6794.65	3490.87
Battery Capacity Required [Ah]	7	7	4
Battery Dimensions	5.94" x 2.55" x 3.74"	5.94" x 2.55" x 3.74"	4.53" x 2.99" x 1.26"

After the total energy charge was determined in each of the states, the 93% conversion efficiency for the output power of the buck converter was factored in to produce the measurement of total power consumed for the nominal cases. The nominal results of this testing confirmed that the team's chosen battery was indeed suitable, as was previously indicated by the first round of power draw testing. Last minute hardware issues prevented us from retesting with the INA219 current sensor module.

Evaluation

The first round of testing from which we determined the battery capacity and physical size was heavily reliant on the assumption that the nominal values were achievable and that the state of sensor code at the time of testing meant that we improperly assumed that the NRF transceiver module was turned off and not transmitting. This would make sense because we were

under the impression that the BLE “power down” command was able to send the board into the proper rest state, when this library was not supported by the regular Nano board, so the sensors were not properly powered down and the transceiver module was continuing to transmit. The multimeter is unable to detect transient changes in the current consumption of the peripheral device, and thus we were also improperly asserting a gross overcalculation of the current draw while the device was supposed to be in rest mode.

Realizing these factors caused us to purchase our chosen battery and proceed with the assumption that nominal values were more accurate, contradicting what we had previously stated. This approach seemed much more feasible after nominal estimates of the final design’s power consumption.

Based on the results of the final round of power draw testing, we have chosen a battery that can supply the system with power reliably for 30 days. However, experimental values were noticeably smaller than nominal. We attribute this to a lower than expected current draw of the sensors and the Arduino while in its idle state. However, we do not foresee low current draw being an issue, as our battery is still capable of supplying more than the necessary power for the full compost cycle, thus meeting the design requirements as we have outlined.

Design Requirements

3.5 Mitigates additional labor and unnecessary contact with compost.

Associated Tests: Bluetooth Communication Test

The connection strength across the range between two BLE enabled devices was tested through various barriers designed to mimic the composting environment.

Objectives

The objective of this test was to determine the range from the compost vessel at which an operator would be able to reliably use our monitoring and alert system. The extent to how far the operator can be stationed away from the compost based on the range of the our chosen BLE protocol, through obstacles simulating barriers present in the compost, including the vessel walls, compost itself, and air, will determine how much our device mitigates unnecessary contact with compost.

Features Evaluated

We designed this test to confirm that the operator would not have to get in direct contact and manually insert probes in the compost; a key feature of our device is wireless transmission of compost vitals (temperature, humidity, and oxygen levels) and care instructions via the BLE communication protocol. The features that were evaluated in this portion of the project were the prototype’s ability to communicate between central and peripheral BLE enabled devices over distance to send sensor values. The reliability of the connection strength observed with our chosen peripheral microcontroller will give us an idea of how far away from the compost an operator can be stationed and also how burdensome the task of using our device will be from a labor perspective. We evaluate how easily we enable the user to record compost vitals from outside the vessel. If our data can be reliably transmitted, the operator can determine quickly any additional physical work that needs to be applied to the compost to maintain healthy conditions.

Test Scope and Key Test Conditions

The first iteration of final prototype testing was performed inside the team’s in-vessel composting test environment, and then with the decommissioned vessels from Mabee’s previous

composting effort that we were granted access to by our project sponsor. Our chosen Arduinos were separated from each other at varying, specified distances. The microcontrollers were turned into the active state where they attempt to establish a connection, and we observed the signal strength and assessed the reliability of the BLE connection between them. Signal strength was measured through barriers of PVC, organic waste, and the 3” metal walls of the decommissioned composting vessel.

Instruments/ Test Setups

The instruments we used to perform this testing included both Nano BLE 33 microcontrollers with power supplies, a measuring tape, and a cell phone with the nRF Connect app to display received RSSI values.

Assumptions

We assume that the maximum range we observe consistent connection between the Arduinos, with test barriers in place, is representative of the max communication range we can expect from our final design in field use. Our evaluations of this design requirement rely on extrapolating the attenuation effects of test barriers to a full-scale in-vessel composting system. We assume that these barriers introduced in testing are representative of barriers that will be present in a typical in-vessel composting operation. Our sensitivity threshold used to formulate the acceptance criteria is assumed to be appropriate for determining if sensor values can be reliably transmitted. A healthy signal strength range is considered to be within -60 to -89dBm. We expect connection strength to remain consistent over the course of 30 days, with negligible effect on the function of our design from temporary spikes when the central BLE device is scanning for data.

Acceptance Criteria

In order to claim successful results, these series of tests must demonstrate that the peripheral unit is able to establish a connection with the central unit through each applied barrier at the request of the master, with no more than one failure out of 15 total attempts. A failure is defined as a reading outside the healthy signal strength range within 2 meters with barriers present. Two meters is deemed to be the bare minimum distance at which the operator can foreseeably stand

Test Results

Results of the communication testing between the two microcontrollers is tabulated in Appendix L. For each of the first round of prototype trials at varying distances, except for the 420 cm distance, the central device was successfully connected, stayed connected and requested the RSSI values and then displayed them, along with disconnecting from the peripheral inside the retired composting vessel; the BLE testing was a success. With additional metal and plastic barriers due to the location of the retired composting vessels and the availability of space, the connection still did not deviate significantly from what was seen before. The data for the tests done inside the team’s composting unit can be seen in Appendix L; the peripheral and central were able to stay within the healthy range of dBm and send service information. The test with the team’s composting unit failed at a distance of 270 cm, however. Additionally, because the central device failed to recognize the device at 420 cm and at 270 cm in the actively composting unit, RSSI information at those distances may prove to be necessary to understand the range of the microcontrollers themselves as well as their behavior with certain strengths of BLE signals. With the use of other peripherals that are capable of connecting and sensing the device, that information was available. Using a similar approach to our subsystem testing, RSSI values were obtained using a mobile device with the nRF Connect application upon connection; the table

with these values can be seen in Appendix . The RSSI values consistently went out of the acceptable range of dBm values (well into the -90s), thus indicating why the connection between the microcontrollers was seemingly nonexistent. The microcontrollers will not connect to any device with a RSSI value of less than -89 dBm. The BLE capabilities of the arduino boards chosen is sufficient to deliver data within reasonable operational distances from the composting vessel (up to 200 cm from vessel) and will not require any additional boosting of signal to keep the prototype operational in this field.

Evaluation

Our device successfully delivered data to the central, a user in combination with the user manual, and will enable the user to determine whether they need to physically do something to administer specific compost corrective actions. This will limit the amount of time the user will have to be exposed to the compost as well as the time the user will have to be in proximity to the compost as well. Therefore, we have met the design requirement of reducing the amount of labor required by the workers.

3.6.1 The system must be durable and reliable enough to last through multiple composting cycles.

Associated Tests: Impact Test

This test was designed to confirm that our final sensor capsule prototype is durable enough to last multiple compost cycles and withstand possible forces of impact.

Objectives

The principal objective of this test was to verify whether the sensor capsule is capable of withstanding the blunt force trauma of an auger striking the capsule. This means that the capsule's ability to protect its interior must not be compromised as the result of a physical impact. The team wants to ensure that the sensor capsule will be able to carry out its function regardless of whether it is struck by a mixing implement.

Feature(s) Evaluated

This test evaluates how closely the sensor capsule is able to meet the durability design requirement: the system must be able to survive multiple composting cycles. The capsule must be able to withstand physical impacts without cracking and exposing its interior to the compost environment. If the capsule's mechanical strength is compromised, the system will be unable to fulfill its job in sending measurements of compost conditions, as the high humidity of the compost environment will most likely irreparably damage the capsule's internal electronics.

Test Scope and Key Test Conditions

Impact testing was performed by using a metal shovel to repeatedly strike different parts of the sensor capsule. In order to ensure similar impact forces for all tests, the capsule was placed on the ground and secured in place. A metal shovel was then dropped vertically from a distance of 0.61 m and 1 m, which archives an impact velocity of approximately 3.46 and 5 m/s, respectively. The former velocity is akin to a light shovel thrust while the latter is approximately equal to a hard and forceful shovel thrust. The shovel was dropped three times from 0.61 m and three times from 1 m.

Instruments/ Test Setups

For this test we used the prototype, a shovel, ladder, and measuring tape. One team member would stand on the ladder while the other one would measure out the desired drop height. Then, we would drop the shovel directly onto the prototype to simulate impact.

Assumptions

The team determined the two impact velocities for this test (3.46 m/s and 5 m/s) by analyzing video footage of a light and hard thrust. As such, we are assuming that the sensor capsule will be subjected to the blunt force trauma of human actions, which is why we ascertained that the highest impact velocity that is reasonably possible is approximately 5 m/s.

Acceptance Criteria

In order for the sensor capsule to meet the durability requirement, it must be able to withstand multiple shovel impacts without experiencing complete mechanical failure (i.e., cracks that would expose the internal electronics to the exterior environment). As such, any damage to the capsule cannot be more severe than scuffs and scratches that do not pierce the capsule.

Test Results

The team dropped the shovel onto the sensor capsule a total of six times, three times from a height of 0.61m and three times from one meter. Appendix K shows photos of the testing setup as well as the effects of the drop test on the capsule. Figure 4, displayed below, is a close-up photo that shows the end result of the six drop tests on the capsule's exterior. The first, second, and fourth gash represent the damage sustained from a drop height of 0.61m drop, while the remainder are sustained from a drop height of one meter.

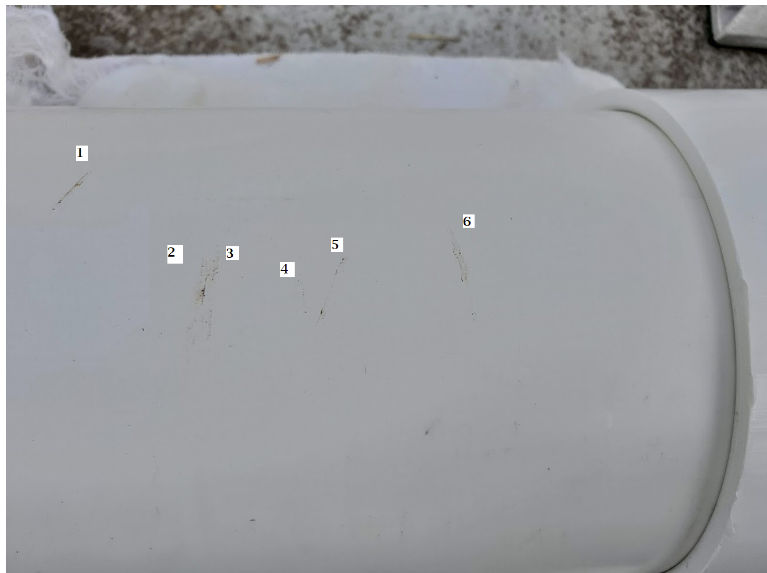

Figure 4. Close-up shot of the sensor capsule following the six drop tests; each gash is numbered for ease of identification

Evaluation

The sensor capsule was able to withstand the six shovel drops with only superficial gashes and scuffs and no mechanical failures or cracks present. As such, we consider the sensor housing to have met the durability requirement, and are confident it will be able to survive a full composting cycle, regardless of whether it is struck by an auger.

Associated Test: Humidity Test

This test was designed to see if the sensor capsule design is capable of safeguarding the electronics inside from the compost environment.

Objectives

The main objective of this test is to ensure that the sensor capsule is capable of safeguarding the electronics contained within from the compost environment. As part of this objective, the quality of the seal between capsule components were likewise verified to ensure that no liquids seep through. We want to ensure that the chosen sensor capsule material is suitable to last multiple composting cycles.

Feature(s) Evaluated

This test evaluates how well the sensor capsule meets the durability and reliability design requirement; it also determines the design's capability to survive multiple composting cycles while recording reliable measurements.

Test Scope and Key Test Conditions

While last semester's tests merely simulated conditions inside a composter (high humidity and possible blunt force trauma as a result of an auger), this test will place the sensor capsule prototype within the team's composter at the CSI Greenhouse to emulate a more realistic environment. This test provides a true compost environment to accurately evaluate the capsule's durability and performance against high humidity and bacteria-laden particulates. However, the scope is limited by the amount of time available to run the test. It will therefore not be possible to determine the sensor capsule's performance through a full composting cycle, but instead its ability to withstand the conditions of an in-vessel composting environment reasonably well, so we can safely assume it will last a full composting cycle. Testing the capsule within a realistic composting environment may neglect consideration for the extent of time which the capsule will be exposed to the compost environment, but offers a better idea of the suitability of the material for an overall prototype compared to purely testing the mechanical strength, chemical resistance, porosity of the material individually etc.

The test was conducted on the 37-gallon composter purchased by the team last semester. The compost consists of around 50 lbs of organic waste acquired from Mabee Dining Hall, as well as high fiber chopped forage and pine shavings at a roughly 4:2:1 ratio, respectively.

The sensor capsule contained four cobalt chloride humidity test strips that recorded the highest amount of relative humidity found within the capsule. These strips were distributed throughout the capsule: one inside with the electronics, one in between two of the membranes, one on the outside of the membranes, and the last one on the removable end cap with holes. The last strip served as a control, and was placed within the composter to measure the compost's relative humidity.

The capsule was mixed within the composter and allowed to rest for approximately one hour. Once the hour has elapsed, the sensor capsule was removed, its exterior wiped down, and its contents evaluated. Over this hour period, the vessel was also stirred, opened, and prodded as needed to maintain the compost, after which we were able to assess if the capsule had sustained any damage from being moved around the vessel and if the capsule fittings loosened and suffered from leakage as the device was used in the vessel.

Instruments/ Test Setups

For this test we used cobalt humidity test strips, the composting vessel, and our completely assembled prototype. The cobalt humidity test strips reveal, on a scale from 0-100%, how much humidity that the environment is experiencing.

Assumptions

We are assuming that the humidity test strips are unaltered by ambient humidity before they are fixed inside the capsule and placed inside the compost vessel; thus the humidity percentage we determine based on the color of the strip is assumed to be accurate based on our best guess.

Acceptance Criteria

For the sensor capsule to meet the durability and reliability design requirements, no more than a negligible amount of liquid may enter the capsule; mesh used to filter air entering the pocket where the sensors sit must not be noticeably damped. Additionally, if the humidity test strips indicate a value greater than 60%, our compost is outside the range of acceptable humidity, which may skew the amount of moisture that enters the capsule.

Test Results

It was crucial to ascertain how well the sensor capsule protected the electronics inside from the hot and humid compost environment. The final prototype is open to the ambient environment via four small air holes on the top of one of the fittings, with nylon mesh serving to block compost particulates and allow air to pass into the capsules. After placing the capsule in the vessel for roughly 1 hour with frequent turning and other disturbance, the capsule was removed from the compost, wiped down, and its contents opened. The five humidity test strips were taken out, the photos of which can likewise be found in Appendix __. The control strip had a relative humidity of over 80%, as indicated by the strip's four squares turning pink. Inside the sensor side of the capsule, the highest humidity found was approximately 20-40%, which is desirable, as that side of the capsule is supposed to be exposed to the compost environment. The strip on the arduino side of the capsule did not display a humidity higher than 20%, which is desired. Photos of the test results can be found in Appendix D.

Evaluation

Because the humidity test strip inside the capsule with the Arduino showed less than 20% humidity, we can conclude that our membranes were efficient in keeping them protected from the composting environment. Because we were able to protect the components from outside conditions, we consider this test a success and we met the requirement that the device must be durable.

Associated Test: Power Draw Test

The power draw test was also taken into account to determine if the system can reliably deliver measurements for the course of a full composting cycle, since if the system loses power at any point throughout the composting process, it cannot deliver sensor measurements that are taken into account for appropriate corrective action.

Details of the test objectives, scope, setup, instruments, and assumptions are stated in the previous power draw test section.

Evaluation

Properly evaluating if the design meets this design requirement induces additional assumptions. Nominal values were originally developed as a base estimate of what we could hope to achieve based on nominal current draw for each of the components. The notion of the INA219 sensor serving as the conclusive measure of power consumption must be contradicted in order to safely state that we met this requirement with our chosen battery. However, there is

evidence of the validity of this assumption. Our final design, based on thorough research, likely meets this requirement.

3.6.2 The system must deliver accurate measurements throughout the entire duration of a composting cycle.

Associated Test: Sensors Test

Each sensor, incorporated into the overall system, was assessed to see if they continued to withstand simulated compost environments while measuring their respective values accurately, precisely, and consistently.

Objectives

The objective of this test was to determine if the peripheral microcontroller's ability to collect accurate and consistent data readings from each of the sensors is adequate for the project. If being placed in a composting environment affects the overall reliability of the sensors, then they may not deliver accurate measurements during the composting cycle. We intend to make sure that the sensors we chose perform correctly and measure their respective values accurately, precisely, and consistently, while they are protected by an internal membrane and exposed to an ambient compost environment similar to a setting for which the monitoring system is planned to be implemented.

Features Evaluated

This test was designed to evaluate the accuracy of the chosen temperature and relative humidity sensor along with the oxygen sensor as part of an integrated prototype. The features that this test evaluates are the ability of the sensors to record accurate and precise measurements and see how they perform in composting environments that simulate some of the environmental conditions they will have prolonged exposure to once used to monitor a full composting cycle.

Test Scope and Key Test Conditions

For the purpose of sensor testing, we consider nominal temperature and humidity values to be the values obtained by the handheld thermometer and soil moisture probe, seen in Appendix F. Nominal values for oxygen concentration were either recorded by the gas meter, or based on the average oxygen concentration in the atmosphere.

The first iteration of the final prototype was constructed around a standard Arduino Nano which employed an RF transceiver module to wirelessly deliver sensor readings to another transceiver module connected with an Arduino Uno. It is important to note that at the time of testing, using RF transceiver modules was the only way that the team was able to wirelessly record sensor values within the compost, in large part due to the steep learning curve of the Nano BLE 33 software.

For this first version of this test we used Arduinos powered by an external 9V lithium polymer battery stepped down to provide a 5V source voltage, the DHT22 temperature and humidity sensor, and the DFRobot Gravity I^2C oxygen sensor, along with the other electronics mounted on a breadboard placed snugly on a 3D printed PLA tray. The electronics were placed in the team's composting vessel in the greenhouse. Measurements of the relevant parameters - temperature, relative humidity, and oxygen concentration were simultaneously recorded, along with measurements by hand, over the course of three hours. Sensor values between the two methods were also compared when the prototype was not placed within the sensor capsule and thrown into the compost to ensure we were observing consistent sensor behavior regardless of interference from the compost environment, and glean more information on the sensitivity and

precision of our sensors. We were particularly interested in determining whether or not the cotton mesh filter and small gap of space containing the sensors, of which a larger version has been constructed for the next iteration of the final prototype, would affect the amount of air that is allowed to pass through, possibly skewing the oxygen readings and the relative humidity. We qualitatively compared the precision of the measurements obtained by our prototype sensors to the nominal values from handheld instruments. The key measurements will be the variance between the value of parameters obtained by our prototype and the value gathered and read directly off the sensors, taken as close to the exact same location in the compost as possible. Data tables from this round of testing can be found in Appendix F.

This method of testing was repeated in covered static compost heaps courtesy of the Compost Queens that offered a representative food waste volume and thermophilic temperature range similar to the in-vessel composting units in which the device is planned to be used. The volume of compost offered for this round of testing was roughly 160 cubic feet. This style of composting differs from the intentions of Mabee Dining Hall in that the compost process is supposed to be anaerobic, and the typical moisture range is around 70% as opposed to 40-60% [4]. The sensor capsule and handheld probes were placed about one meter laterally into the compost, and buried under roughly three feet of compost. Once again, a series of measurements were taken over the course of the visit, and the handheld probes we have been using were placed as close to the same spot as possible, to assess whether or not the sensor were recording values that were suitably accurate. It is important to note that data collected was observed from the serial monitor of a laptop with a wired USB connection that was fed into the body of the compost for this round of testing. A complete overview of the data collected is tabulated in Appendix F. Photos of the experimental setup can be found in Appendix F.

For both rounds of testing, the team was aware that changes in the parameters inside a composting vessel do not change quickly, and that several hours may pass before noticeable changes in the compost parameters can be observed [35].

Instruments/ Test Setups

The instruments used for the first iteration of prototype testing included a handheld mercury thermometer, a Sonkir 3-in-1 soil moisture, pH, and light sensor, a DFRobot I^2C oxygen sensor, a gas meter, a DHT22 sensor attached to our Arduino Nano, an Arduino Uno connected to a serial monitor, wireless transceiver, and wires and other electronic components that make up the peripheral microcontroller unit. We accounted for the nominal uncertainty in the measurements with these sensors to have an idea of what an acceptable deviation in the parameters might be. The oxygen sensor was calibrated in atmospheric conditions and given three minutes to heat up in order to take accurate measurements as prescribed by [9]. Our in-house composting environment in the greenhouse was used as the testing environment for the first set of results.

As the design has evolved, the instruments used in the test have been altered. The second round of testing with Compost Queens was conducted with the same handheld probes used all year, but without a gas meter, meaning that average ambient oxygen concentration was used for nominal comparison. The instruments that have been updated include an Arduino Nano BLE 33 as the base microcontroller, which was the only difference for the sensor testing repeated and detailed in Appendix H. The design has now evolved to make use of the DHT20 temperature and relative humidity sensor for the final round of prototype testing. A series of 6 measurements and a similar collection process was repeated for the second round of testing with Compost Queens, but the scope of testing was limited to a little over an hour.

Assumptions

We are assuming that the conditions within the composting vessel will not exceed the 185°F upper operational limit of the DHT22 and DHT20 sensors [7-8]. It is unlikely that the compost will operate with an internal temperature above 160°F. We assume that if the compost the team has been producing is more hot than the optimal operating temperature range for the oxygen sensor, 122°F, that the oxygen concentration value is still accurate enough for our purposes. Another prominent assumption is that the sensors we have been using since last semester are accurate enough to be used as a reference. We assume that the functionality of the sensors will be unaffected by the material encapsulating them. Additionally, we are assuming the durability and reliability of the sensor observed in a limited time period of testing will reflect the reliability and durability we can expect throughout the entire composting cycle. Also, our sensor may operate outside of the accuracy range indicated by the datasheet at times. We are assuming that brief periods of temperature outside of the 32-150°F “accurate” range of the DHT22 sensor might arise and have a negligible effect on accuracy, that these periods will be infrequent, and that the overall durability of the sensor is not harmed by exceeding this temperature range occasionally [8]. We are assuming no uncertainty in the measurements from the control sensors. Finally, we are assuming the average ambient temperature of the compost captured by the sensor in a given area has negligible error from the true temperature. We are also assuming that the thermophilic environment and volume of compost in the static heap bins are adequately harsh conditions to demonstrate that the sensors continue to perform consistently. For instances where the gas meter was not available to use as a control, the team assumed that the concentration of oxygen in the air was 21.0%, typical of the atmosphere.

Acceptance Criteria

In order to adequately monitor the compost, we expect that the accuracy of the measurements obtained by the sensors should reflect their nominal accuracy: $\pm 3\%$ relative humidity and $\pm 0.5^\circ\text{C}$ for the DHT20 [7], and $\pm 5\%$ relative humidity and $\pm 0.5^\circ\text{C}$ for the DHT22 used in the first round of sensor testing, as well as testing conducted at the Compost Queens test site. Nominal accuracy of the oxygen sensor was not included in the product data sheet, so this portion of the test was deemed a success if the accuracy did not exceed $\pm 1\%$ oxygen per unit volume of air. Similarly, the acceptance criteria for the precision aspect of the testing was determined qualitatively and aligned with the listed resolution for the sensors: $\pm 0.1\%$ relative humidity and $\pm 0.1^\circ\text{C}$ for the DHT20 [7], and 1% relative humidity and $\pm 0.2^\circ\text{C}$ for the DHT22 [8]. For the oxygen sensor, we hoped to observe a precision of roughly 0.15% volume for repeated measurements [9]. Due to the relatively small absolute values of these listed uncertainties, it is likely that for the purposes of maintaining aerobic compost, slight deviations outside of these ranges will be acceptable, as the conditions within the compost vary frequently by location. Therefore, considering the inherent uncertainty and possibility of user error when taking measurements by hand, the DHT sensor will be deemed appropriate if we observe that the measurements are within 10% error of nominal values. The oxygen sensor will be deemed appropriate if we observe less than 1% absolute error.

Test Results

The first round of sensor testing produced promising results. Test setups and results are included in Appendices G and F, respectively. The temperature, humidity, and oxygen readings recorded below were taken over the course of a 3 hour period, with a comparative reading from our handheld probes each 30 minutes. Fortunately, none of the readings exceeded the 10% deviation limit from the value obtained with our standard sensor, which we are considering to be

accurate. Differences were generally moderate, as only two trials out of six found deviations in the temperature that exceeded the $\pm 0.5^{\circ}\text{C}$ measurement uncertainty inherent to the DHT22 sensor. We only plan to consider integer temperature values for ease of processing and understanding by the operator, and across several of the trials, the temperature recorded by the sensor almost identically matched the temperature recorded by the handheld probe at the same location. Also, extensive data was not collected to prove that the chosen sensors are precise in a single area once it was realized that no difference larger than 0.05°F and 1% humidity was observed when holding the probe steady and taking measurements. Based on this initial prototype testing, it appears our sensors can measure accurately as they are moved throughout the compost. Additionally, the DHT22 sensor remains functional, additionally supporting its usage in our final design that is intended to withstand multiple composting cycles, and appears to have no difference in accuracy as the peripheral sensor capsule is turned in the vessel.

Humidity and oxygen concentration variations from the first round of testing can be seen in tables contained in Appendix F, along with a breakdown of the absolute error in oxygen measurements. Before the sensor and electronics were placed inside the capsule, the oxygen sensor was recalibrated and given three minutes to acclimate.

Photos of the second round of sensor testing, which were conducted in a more realistic setting with a second iteration of the prototype are included in Appendix G. Data is tabulated for each sensor in Appendix F. Our oxygen sensor displayed even smaller absolute errors throughout this round of testing, suggesting that it performs considerably better under a mass of thermophilic compost.

Results of the second round of oxygen sensor testing are also tabulated in Appendix F. It is important to note that the value of oxygen concentration for ambient conditions is typical in the atmosphere: $\sim 21\%$ [24].

Evaluation

From the first round of testing, it was evident that the sensors recorded consistently accurate values, with the exception of one trial where the humidity exceeded the 10% acceptance threshold. Errors were generally insignificant. However, this initial testing was the first glimpse at a prominent problem observed in sensor testing - the values recorded by the temperature and humidity sensor were consistently lower than nominal values. Further testing indicated with an extended period inside the compost to acclimate, the sensors are likely able to measure accurately, and that these lower-than-expected values are likely not attributed to the placement of the sensors within the capsule. Our concerns are further eased due to the fact that the compost takes 2-3 days to heat up to around 104°F . Around these temperatures, the sensors seem to perform accurately almost immediately.

The relative humidity sensor of the DHT22 was largely successful in the first round of sensor testing, despite the larger percent differences noted than those from the temperature sensor. One out of the six trials produced an error outside of the acceptable deviation in this test, but accounting for the 2% uncertainty of the sensor, it is reasonable to conclude that the humidity sensor recorded accurate results. Generally, no unacceptable deviations were observed when comparing humidity values obtained with our chosen project sensor and the nominal values when accounting for measurement uncertainty.

Some large absolute differences were observed, which was concerning since the ideal range of compost humidity is between 40-60% and the sensors recorded up to a 9.40% difference from the nominal humidity value at the same location in the compost. However, this was likely due to the fact that the handheld probe was very sensitive to the pressure applied to it, as well as

the fact that the ambient pocket from which the sensors were measuring became more saturated with liquid as the vessel was turned. The humidity measurements obtained during this round of testing were all from the surface of the compost or, no more than an inch into the compost from where the capsule was stationed when the door was opened. It could be seen that the moisture decreased from about 90% to as low as 35% as the handheld probe was moved through one plane. We compared measurements taken from as close as possible to the same spot as the nominal values, but slight variations in pressure placed on the handheld probe are likely causes for these differences.

Based on the moderate differences observed between temperature and humidity data taken in the team's in-house composting environment by the prototype sensor and the nominal values, it appears that the team's chosen DHT22 sensor is appropriate for measuring the compost parameters accurately and consistently. The sensor records values that align reasonably well with nominal values. Also, the sensor itself is demonstrably precise enough to be suitable for our design. However, we have only been able to verify the function of the sensors and other electronics function when exposed to temperatures up to around 110°F during the building of the device and testing in hot outdoors environments with long periods of sun exposure. In general, our in-house composting environment is not reflective of the typical thermophilic compost environment, but testing inside this vessel granted confidence that the values of the temperature and humidity obtained by this sensor were not greatly affected by encasement within the capsule with small openings to the ambient conditions.

The results of the first round of oxygen sensor testing were promising for our final prototype, since it appears that its ability to measure oxygen concentration was not significantly reduced by its placement within the capsule. Thus, we conclude that the oxygen sensor used in our final prototype has suitable sensing capabilities for our final design, and we are confident that it can deliver accurate readings over the course of a full composting cycle with recalibration once every two months [9]. It should be noted that placement of the gas meter inside the vessel required the lid to be opened periodically, resulting in aeration of the compost and exposure of the gas meter to ambient air immediately prior to its use. This likely explains why the oxygen concentration recorded by the gas meter varied little over the course of this experiment, and was essentially the same as the outside conditions. Also, because we were not able to test the oxygen sensor in a compost environment consistently above the upper range of the sensor's optimal temperature operating limit of 120°F, it is likely that the accuracy of this sensor would be affected if used as part of the final design [9]. However, based on this round of testing, it appears that the oxygen sensor is suitable for use as part of our final prototype design, since it can monitor and deliver accurate oxygen readings when it is placed inside the vessel. It appears that the thin cotton mesh we fixed over the openings to the compost environment obstructs disruptive debris without impeding sensor function. Additionally, as the capsule was slowly turned and shaken in the compost, the oxygen measurements varied more than the prescribed $\pm 0.15\%$ resolution, but once settled, precise measurements that varied by no more than 0.10% were relayed by the peripheral device to the Arduino Uno stationed outside the vessel.

Based on the results of sensor testing, we are confident our chosen sensors will remain sufficiently accurate when housed inside the sensor capsule and placed in the simulated compost to deliver accurate monitoring. However, since we were unable to test the sensors under all expected conditions, including higher temperatures, greater volume of food waste, and greater frequency of rotation, further testing needed to be conducted in a suitable environment.

A second round of testing conducted at the Compost Queens' compost units demonstrated that the sensors continued to function as expected when placed in a large, hot, humid, thermophilic composting environment, and that the PVC sensor capsule provided a functional barrier without impeding sensor function. Additionally, because the temperature readings fell significantly below the nominal compost temperature, but gradually increased over the course of testing, we know that the temperature sensor needs time to acclimate. Because we have demonstrated several times that the DHT can record accurate readings while probing humid compost, and assuming that it will heat up to match the ambient conditions in a linear manner, this test demonstrated that we should allow the capsule to be placed in the compost 6-7 hours before it can provide accurate readings. Also, this test was a helpful indication that more waterproofing was necessary, evidenced by the humidity test strips shown in Appendix F indicating worrisome levels after the capsule was immersed in a compost environment after only an hour.

It was apparent that the DHT22 sensor can take precise measurements, and the first round of testing demonstrated that measurements taken at the same time and place do not vary outside the listed resolution of the sensors on the DHT datasheet. However, unacceptably large deviations were observed for both temperature and humidity during the second round of testing with Compost Queens. Because the scope of testing was limited, and because the compost merely approximated a thermophilic environment, we elected not to change the sensors chosen for the design. It is reasonable that with proper setup and more complete design, including adequate time for the sensors to acclimate, our chosen sensors are suitable. Because the DHT22 and DHT20 sensors are from the same sensor family, many of the conclusions made from the first and second rounds of testing are applicable for our final design that employs a DHT20.

3.7 Includes a training manual for operation of the system with commands that are easy to understand by someone with limited composting knowledge

Associated Test: Ease of Understanding

The test was designed to confirm that our corrective actions are easy to understand by someone with limited knowledge of composting.

Objectives

A goal of the test is to meet the design requirement of inclusion of a training manual for operation of the system so that any employee can easily interpret and complete instructions. The device must be intuitive enough to be used by any employee regardless of their composting knowledge.

Features Evaluated

The design feature that was evaluated by this test is the device's ease-of-use by someone with limited composting knowledge.

Test Scope and Key Test Conditions

We conducted a survey among four participants with limited composting knowledge to gauge their ability to understand and correctly follow each command included in the draft of our

training manual. Participants rated the following statement for each command according to the Likert scale.

Command _was easy to understand and the specific actions could be carried out without additional instructions.

Instruments/ Test Setups

The team conducted a survey-style test, and employed data collection with a Likert-style opinion poll via pen and paper. The Likert-scale included responses of: strongly agree, agree, neutral, disagree, and strongly disagree. We also compared each command with the participant's stated answer detailing the actions they would take in response. The list of possible commands can be seen in Appendix A.

Assumptions

For this test, we are assuming the participants are English speakers. We also assumed that the participants will have access to the Training Manual for reference, and that the four participants have the same level of knowledge of composting that an operator has.

Acceptance Criteria

In order to meet the design requirements, the participants should be able to state/identify the actions that should follow the given corrective actions and either agree or strongly agree with the Likert scale survey question for each command. Their survey was evaluated by each of the team members to determine the results of the test.

Test Results

After writing the corresponding specific actions for each command, the participants rated the following statement for each command: *Command* _was easy to understand and the specific actions could be carried out without additional instructions. The survey results can be seen in Figures 5-8.

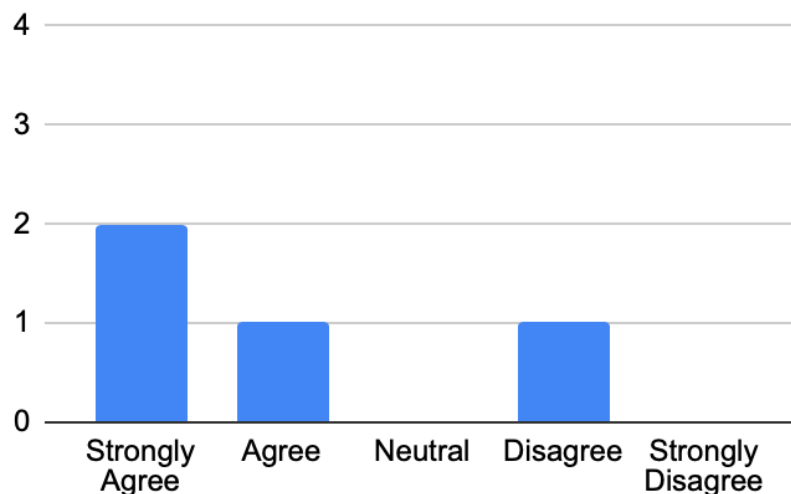

Figure 5. “Mix” Likert scale survey results for the following statement: *Command 1* was easy to understand and the specific actions could be carried out without additional instructions.

According to Figure 5, the mix command was not easily understood by all of the participants. This could be due to the fact that we used the word “auger,” which some may not be familiar with. We rewrote the “Mix” command to say: “Mixing the compost is necessary. Use the internal mixer, whose handle is on the outside of the compost, to “mix the compost a few times.” In order to confirm that this rewritten command was easy to understand, we completed the Likert-scale survey, shown in Figure 6.

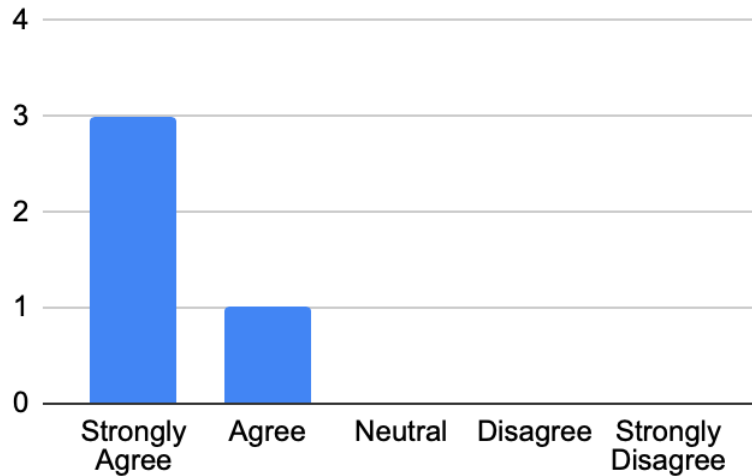

Figure 6. The rewritten “Mix” command Likert scale survey results for the following statement: *The rewritten “Mix” command was easier to understand and the specific actions could be carried out without additional instructions.*

Figure 6 shows the Likert-scale survey results for all of the following commands: “Add Bulking”, “Aerate”, “Add Water”, “Nothing”, and “Add Waste”. The results for these commands were all the same.

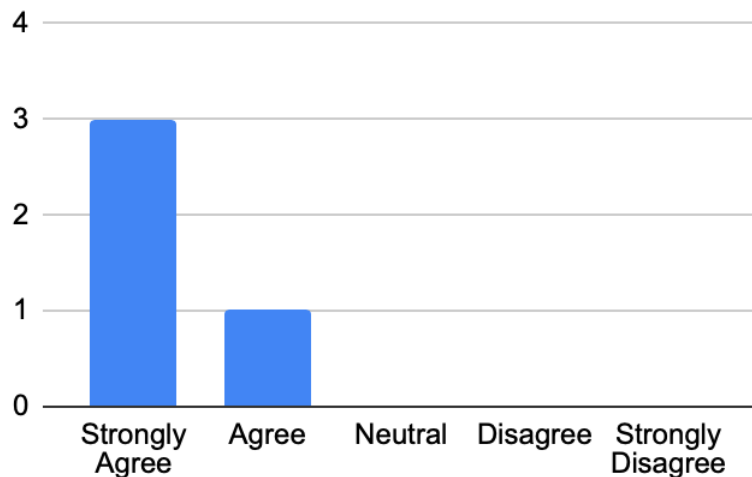

Figure 7. Commands 2-6 Likert scale survey results for the following statement: *Command _ was easy to understand and the specific actions could be carried out without additional instructions.*

Figure 7 shows that the following commands were easy to understand and could be followed without additional instructions: “Add Bulking”, “Aerate”, “Add Water”, “Nothing”, and “Add Waste.” Figure 8 shows the Likert scale results for the last command, “Extinguish.”

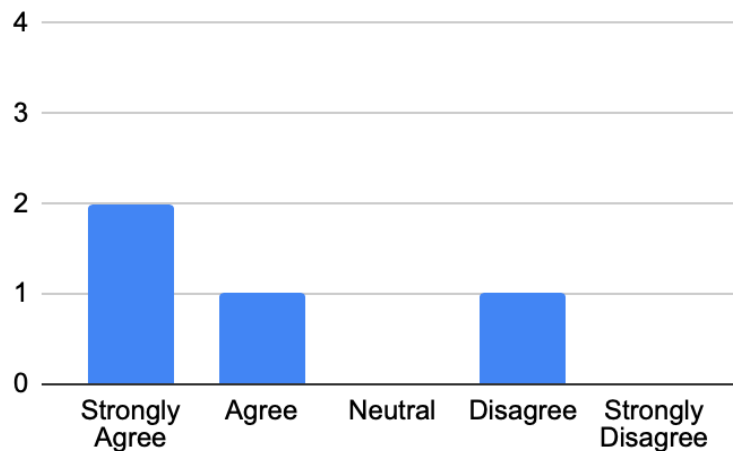

Figure 8. “Extinguish” Likert scale survey results for the following statement: *Command 7 was easy to understand and the specific actions could be carried out without additional instructions.*

The “Extinguish” command was not easily understood by all of the participants. This command is already described in detail in the long form manual that the employees will be receiving, so we therefore omitted it from our shorthand training manual.

Evaluation

The training manual for our device can be seen in Appendix A. Overall, most of our commands were easy to understand with the exception of the “Mix” and “Extinguish” command. In order to correct this failures, we decided to omit the “Extinguish” command and include it in the long form manual with more explanation and rewrote our “Mix” command. After repeating the survey, we came to the conclusion that the new “Mix” command is easily understood by people with limited knowledge of composting. Now, we’ve officially met the design constraint of: includes a training manual for how to operate the system that includes commands that are easy to understand by someone with limited composting knowledge.

3.8 The sensors and probes must take measurements with adequate precision and accuracy to ensure a proper diagnosis has been performed to keep the compost aerobic.

Associated Test: Sensors Test

Refer to previous Sensors Test section.

Objectives

The overall goal of this test was the same as previously stated.

Features Evaluated

To evaluate how well we met the design requirement of “adequate precision and accuracy”, the results listed and evaluated in the previous sensor testing section were sufficient. In this test we examine how accurate the combination of direct sensor data that is processed to suggest various corrective actions, and our assessment of how well the corrective actions are interpreted, and their subsequent influence on the state of the compost, will be in generating a proper diagnosis that can reasonably maintain aerobic compost. This includes a discussion on whether the nominal uncertainty of the sensors, and deviations from nominal values observed through the rounds of testing, are adequate assessments of the compost parameters.

Test Scope and Key Test Conditions

Refer to previous Sensor Testing section.

Assumptions

Additional relevant assumptions include that measurement of compost parameters does not need to be precise in general. Conditions already vary greatly throughout the pile, and we assume that our sensors are accurate once they have time to acclimate to the compost environment. Based on the assumption our sensors are taking accurate measurements, we assume that our logic suggests the best possible corrective action that could be administered by a Mabee employee in order to remedy anaerobic conditions.

Acceptance Criteria

Prior acceptance criteria still applies.

Test Results

Refer to section 3.6.2.

Evaluation

The sensors chosen for the peripheral device adequately measure and deliver the data necessary to evaluate the state of the compost. Appendix F includes the first round testing for the DHT22 and the oxygen sensor with comparisons to nominal values. Appendix F also shows large errors recorded by the DHT sensor, with over 20% error consistently in a static heap compost environment. Oxygen deviation was much improved from previous testing - we are more confident that this sensor is suitable for performing measurements in a larger mass of compost, but need to perform further testing in an environment where we are not just essentially recording ambient oxygen. Errors in the temperature and humidity recorded are likely attributed to nominal data collection methods combined with not allowing the sensors adequate time to acclimate. These errors decreased significantly once the prototype had been submerged in compost long enough to acclimate, and we therefore are confident in the suitability of our sensors.

Because the DHT22 and DHT20 sensors are from the same sensor family, many of the conclusions made from the first and second rounds of testing are applicable for our final design that employs a DHT20.

Associated Test: Arduino Code & LCD Logic Test

This test was designed to prove that we can display corrective actions on an LCD screen powered by an Arduino Nano 33 BLE and Arduino Uno wired together through serial ports.

Objectives

The objective of this test was to determine if the central device could display the appropriate corrective action onto the LCD screen for any variation of temperature, humidity and oxygen level inputs.

Features Evaluated

This test evaluates how effective the central device is at displaying corrective actions through its LCD screen. The screen should display the corrective action based on the temperature, humidity, and oxygen inputs. This test also determines the ability of our compost logic code to deal with any possible inputs while still delivering appropriate commands through the Central unit.

Test Scope and Key Test Conditions

For this test, we used an Arduino Nano 33 BLE and Arduino Uno powered by an Anker 20,000 mAh power bank. We entered various values for temperature, humidity, and oxygen to observe how the compost logic code would respond on the LCD screen. We input a wide array of values to determine how the code would handle either a single or multiple parameters being out of optimal range. An example of the pseudo code for the logic we tested with can be seen in Appendix B.

Instruments/ Test Setups

For this test, we used an Arduino Nano 33 BLE, Arduino Uno, and an LCD screen. We required a resistor and potentiometer to complete the LCD circuit as well as a lot of wires. In order to power the Arduino Nano 33 BLE, we used a micro USB to USB-A cable.

Assumptions

When testing the LCD display and logic, we were assuming that our sensors would be taking accurate measurements. We also assumed that the bluetooth connectability is sufficient enough to provide this data from several meters away.

Acceptance Criteria

We will know our test is successful if we are able to display the correct suggested action given a set of several random parameter inputs.

Test Results

The LCD was able to display the right corrective action depending on the inputs provided. An example of some inputs and displays that we tested can be seen below in Table 8. A photo of the Central displaying “Mix, add waste” is also shown below as Figure 9.

Table 8. Example of every possible scenario for temperature, humidity, and oxygen inputs tested for our LCD logic test and the corresponding displayed corrective actions

Temperature Input [°F]	Humidity Input [%]	Oxygen Input [%]	Corrective Action
200	42	21	“Add water, remove waste”
161	39	9	“Mix, add water”
161	61	9	“Mix, remove waste”
145	42	7	“Mix”
130	10	9	“Mix, add waste”
80	40	21	“Add waste”
140	20	21	“Add water”
145	65	21	“Mix, add bulking agent”
145	48	21	“No action needed”

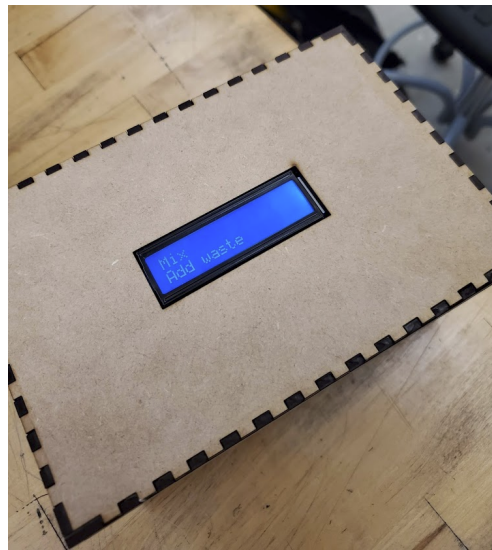

Figure 10. Central displaying appropriate corrective action following test inputs.

Evaluation

Our LCD screen displayed appropriate corrective action for a comprehensive list of scenarios it was tested under, including off-nominal scenarios that are unlikely to arise in a composting endeavor. The right corrective action was displayed for every tested input. We are

confident that as the sensors transmit compost parameters, the central will be able to display in response to the data it processes to issue appropriate corrective actions.

3.9 The solution must be able to be used when composting up to 100 pounds of food waste daily.

Evaluation

We have tested our prototype in a variety of composting environments as seen in Sections 3.2 and 3.8. The tests relevant in our justification of this design requirement were the ease-of-use test and sensors test. Our testing throughout the semester took place in a 37 gallon composting vessel, or around 5 cubic feet. We have tested our sensor capsule in this in-vessel system as well as a large, static heap compost environment courtesy of Compost Queens. The volume of compost offered by Compost Queens was approximately 160 cubic feet. One cubic foot of compost is around 30-50 pounds [30]. This means that the total mass of compost that we tested our prototype in was around 4,800-8,000 pounds. However, we estimate that we were only testing under roughly 10 cubic feet of compost, which demonstrated our sensor capsule is durable enough to withstand the hydrostatic pressure induced by around 400 pounds of compost. Combined with direct impact testing, this strengthened our confidence in the device's suitability to be used in a vessel loaded with 100 lbs of compost daily. Our device took accurate measurements, experienced minimal particle intrusion inside the capsule, and operated reliably under the weight of the compost. Because our system was considered easy to use in a small vessel, and we do not foresee any additional difficulties when used in a vessel at this scale, we are confident that our solution is able to be used when composting at a scale that meets this design requirement.

4. Conclusions

In our most recent project plan, we outlined the delivery of a reliable monitoring system that delivers alerts to maintain aerobic compost. It is unlikely that the system could be turned over to the sponsor at this point and be implemented in any future in-vessel composting system for Mabee Dining Hall, within the listed constraints and requirements, without future work and modifications.

4.1 Design Requirements and Constraints

We were able to meet most of the requirements listed in the project plan. The system was constructed and tested for under \$1200, and is portable and easy to insert into the vessel by someone with a limited knowledge of composting. According to initial power draw analysis, the power system will also be able to power the system for the full 30-day compost cycle. The sensors have also proven accurate and reliable enough during preliminary testing, and the sensor capsule withstood impact tests designed to assess its durability. However, further testing must be performed on the system as a whole over the course of a full compost cycle to determine the actual feasibility of the device during field use.

4.2 Shortcomings

Adverse compost conditions such as excess temperature or humidity could decrease the accuracy of the sensors, so the team recommends updating the code logic to account for this scenario. As there are different stages in the composting process, different logic processes may be necessary for stages at which the compost is not thermophilic. A more durable, industrial oxygen sensor may also be beneficial, though it should be considered that anaerobic compost cannot always be detected with the use of temperature, humidity, and oxygen sensors. Use of a more complex system of sensors falls outside the scope of this project. BLE range has also not been tested through a large enough mass of compost, with all relevant barriers in place at once. The peripheral device takes time to connect to the central device, making it unlikely that an employee could quickly take sensor readings and receive instruction. We cannot guarantee confidence that a successful BLE connection could be established if this device is implemented in an in-vessel composting system, and if so, the device is not reliable enough to mitigate additional labor and contact with the composting vessel. Additionally, we fail to issue a range of comprehensive alerts that could be given for scenarios that our sensors are able to detect, such as oxygen readings below 5%, that are sure indicators that the compost is becoming anaerobic.

Additionally, the sophistication of the central device could be improved with a different user interface such as a tablet or smart device.

4.3 Recommendations

For future iterations of this project, we recommend implementation of RTC capabilities to also allow the code to adjust its logic for different periods of time in the compost cycle. Multiple sensors throughout the compost vessel would give a better idea of the state of the compost, as well as gas sensors to detect formation of anaerobic pockets. A communication protocol designed for longer ranges which can reliably penetrate compost should also be researched.

To some extent, we believe the project is fundamentally flawed and that the best way to ensure an aerobic composting operation for Mabee Dining Hall would not require any employee intervention. We believe that directing efforts into a way to optimize the functionality of a vessel that has integrated temperature sensors throughout its walls, or within the central mixing unit that descends into the compost, which automatically aerates the compost periodically corrects problematic temperatures, would have been a more suitable design option for us to pursue. An automation solution was quickly deemed to be outside our budget or the scope of a school year. Our device, even under best case scenarios, is only slightly more helpful than taking compost measurements by hand and following a compost troubleshooting manual.

Even if we had achieved a working prototype of a self-contained monitoring and alert device that achieved every design requirement and constraint, and demonstrated fully that our prototype acceptably passes tests that could prove these specifications, we are confident that our approach may have not been the right approach for a consistent and fully functional means of ensuring aerobic compost. Based on our supporting research, we now believe that an integrated in-vessel system would be more economically viable and reliant on sound engineering principles than a separate monitoring system retrofitted to a chosen in-vessel composter. This was far outside the scope and budget of our project.

Appendices

Appendix A: Setup, operating, and safety instructions for prototype

Setup

The sensors, battery, and microcontroller are already located inside of the sensor capsule. Likewise, the LCD, powerbank, and Arduinos are contained inside of the central unit. The only setup required for this design is to place the sensor capsule inside of the composting vessel.

Operating

1. Place sensor capsule in the compost
2. Wait at least 8 hours for the sensors to take accurate measurements
3. Bring the LCD box into close proximity of the compost vessel
4. Open central box and press the on button on the power bank
5. Close central box
6. Read the command on the LCD screen and take the following actions:

Safety

Exercise caution when handling the 12V battery.

Charging Instructions for Battery:

1. Plug charger into wall socket
2. Attach charger clips to the corresponding terminals
3. After around 10 hours, the battery will be fully charged

Below is the list of possible commands displayed as alerts by the device. Next to each command are descriptions of the specific actions that an operator should take in order to maintain aerobic compost.

Command	Specific Action
1. Mix	Mixing the compost is necessary. Use the internal mixer, whose handle is on the outside of the compost, to mix the compost a few times.
2. Add Bulking	Bulking agents must be added to the compost. This can include wood chips, hay, or saw dust. 5 pounds of bulking agent will do.
3. Aerate	The compost does not have enough oxygen. In order to aerate the compost, open the lid for approximately 2 minutes, then Mix.
4. Add Water	The compost is too dry. Add 3 cups of water to the compost from the top, then Mix.
5. No Action	The compost is perfectly fine. Do not do anything to the compost.
6. Add Waste	The compost needs more organic waste. Add around 20 pounds of waste.

Troubleshooting

This section should be referenced when issues persist with the compost after following the instructions displayed on the alert screen. It is adapted from the Cornell Composting Troubleshooting guide [17].

Problem	Cause	Solution
Anaerobic odor	Leaf compaction Surface ponding	Mix, Remove ~20 lbs. of compost Eliminate ponding
High Temperature	Window too large Leaf compaction	Remove ~20 lbs. of compost Mix
Vectors Rats Mosquitoes	Presence of garbage (food, etc.) Presence of stagnant water	Remove garbage, or use rat bait Eliminate ponding Cover food with brown materials such as, wood chips or finished compost
Fires/spontaneous combustion	Excessive temperature Inadequate moisture Stray sparks, cigarettes, etc.	Remove ~20 lbs. of compost Add water Keep potential fire sources away from compost If fires do start, break piles apart and extinguish completely
Pile is wet and smells rancid	Not enough air Too much nitrogen Too wet	Aerate Add Bulking Mix, Add Bulking, Provide Drainage
Pile does not heat up	Pile is too small Pile is too dry	Provide insulation or Add Waste Add Water
Pile is damp and sweet smelling but will not heat up	Not enough nitrogen	Mix in grass clippings, food scraps or other sources of nitrogen

Appendix B: Compost Logic Maintenance Instructions Pseudocode

If: Moisture below 40%
Add water, mix

If: Moisture above 60%
Mix, add bulking agent

If: Temperature below 135 F
Add more waste

If: Temperature above 160 F
Mix

If: Moisture below 40% and temperature below 135 °F
Add water, mix

If: Moisture above 60% and temperature above 160 °F
Mix, remove waste

If: Poor aeration (Oxygen below 10%)
Turn compost

Ratios should be adjusted based on the phase of the composting cycle and total volume of the vessel

Please use the following guides as reference:

For each cubic yard of waste, whenever necessary, add or remove:

5 cups of water

10 pounds of waste

10 pounds of bulking agent

Appendix C: Construction of Sensor Capsule

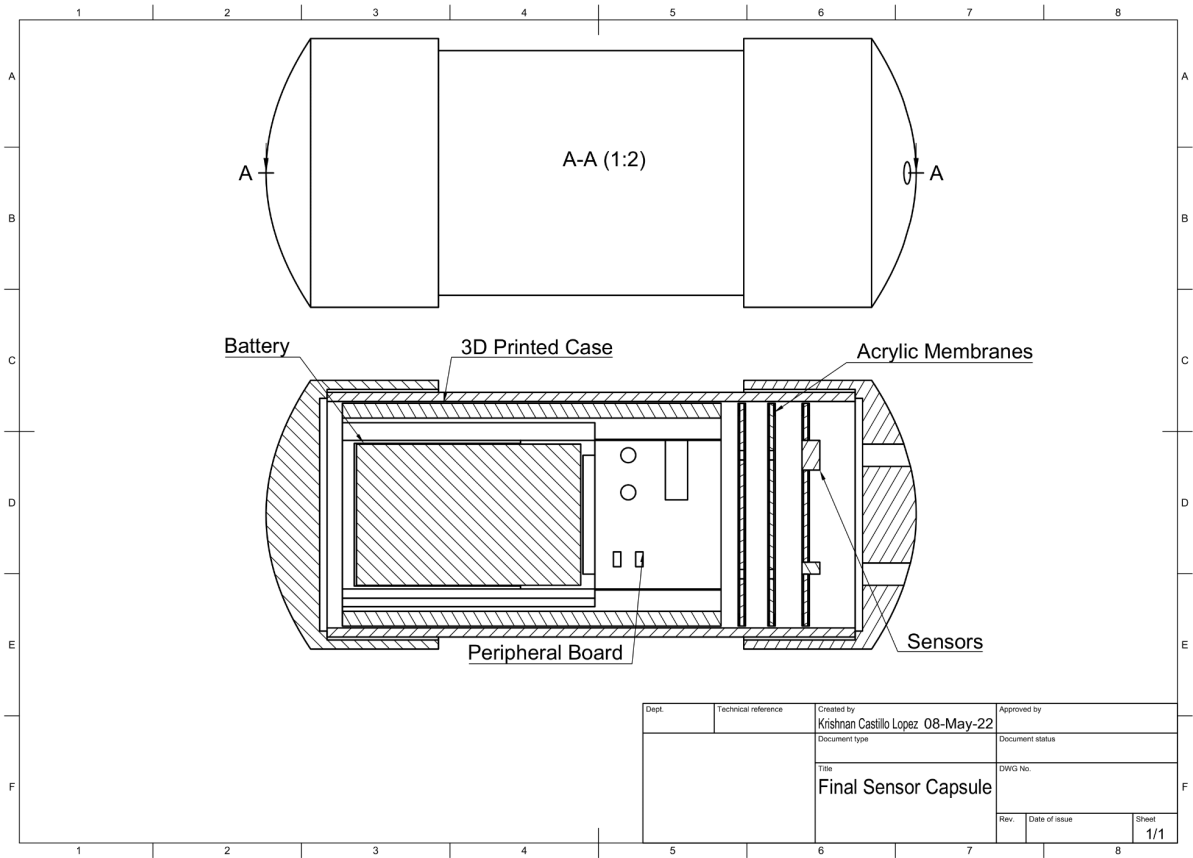

Figure C1. CAD Drawing of fully assembled prototype



Figure C2. Sub-assembly of the inside of the sensor capsule including the battery, breadboard, and three membranes

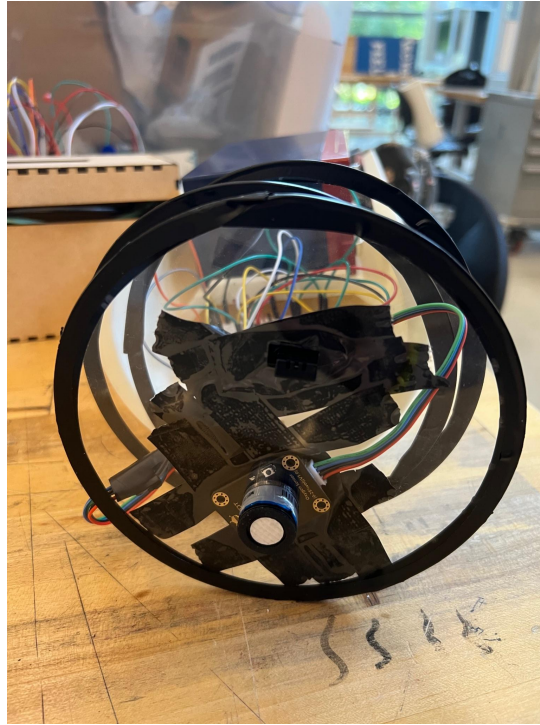

Figure C3. Front side of the sub-assembly



Figure C4. Full view of the sensor capsule and membranes sub-assembly



Figure C5. All of the components inside of the sensor capsule



Figure C6. Sensor capsule fully assembled



Figure C7. Liquid electrical tape on the temperature & humidity sensor

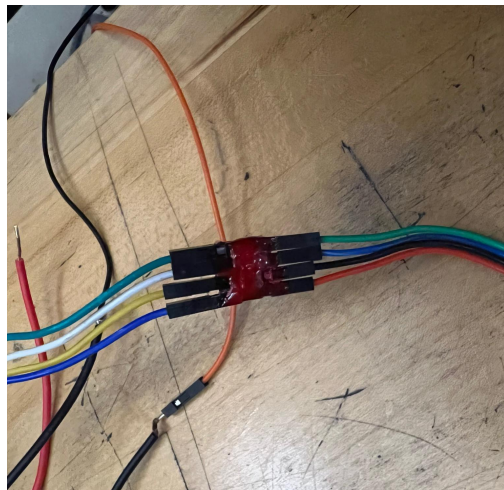

Figure C8. Liquid electrical tape on female to male wires

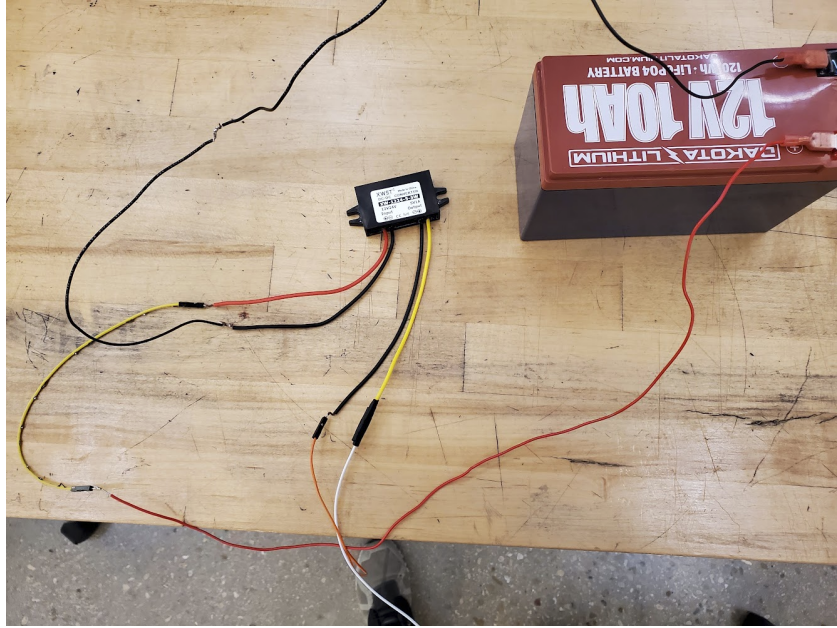

Figure C9. Power supply for peripheral board soldered together.

Appendix D: Humidity Testing



Figure D1. Sensor capsule inside of the composting vessel during the humidity test (white PVC under the compost)

Appendix E: Ease of Use Testing with first iteration of prototype



Figure E1. Participant placing the sensor capsule into the composting vessel



Figure E2. The sensor capsule inside of the composting vessel



Figure E3. Participant pulling the sensor capsule out of the composting vessel after using a shovel to dig it out.

Appendix F: Tabulated sensor testing data from the first round of final prototype testing

Table F1. DHT22 temperature deviations from thermometer temperature in the first round of prototype testing.

DHT22 sensor [F]	Handheld Thermometer	Absolute Error [F]	Percent Error [%]
90.20	91.10	0.90	0.99%
91.30	92.00	0.70	0.76%
91.79	92.50	0.71	0.77%
91.28	93.20	1.92	2.06%
90.89	92.40	1.51	1.63%
90.28	89.90	0.38	0.42%

Table F2. DHT22 humidity variations from the standard probe measurements in the first round of prototype testing.

DHT22 sensor [% RH]	Handheld Probe [%]	Absolute Error [% RH]	Percent Error [%]
65.20	70.00	4.80	6.86%
67.80	72.00	4.20	5.83%
72.40	70.00	2.40	3.43%
75.30	81.00	5.70	7.04%
75.60	85.00	9.40	11.06%
76.10	81.00	4.90	6.05%

Table F3. DFRobot Gravity I²C oxygen concentration variation from gas meter measurements.

Gravity I2C Oxygen Sensor [% vol.]	Handheld Gas Meter [%]	Absolute Error [%]	Percent Error [%]
19.95	20.90	0.95	4.55%
19.65	20.80	1.15	5.53%
20.15	20.90	0.75	3.59%
19.84	20.90	1.06	5.07%
21.01	21.00	0.01	0.05%
20.84	20.90	0.06	0.29%

Table F4. Temperature variations observed when testing in Compost Queens static heap compost.

DHT22 sensor [F]	Handheld Thermometer	Absolute Error [F]	Percent Error [%]
92.1	126.0	33.9	26.9%
93.2	132.0	38.8	29.4%
93.7	136.0	42.3	31.1%
94.3	136.0	41.7	30.7%
94.6	130.0	35.4	27.2%
99.1	132.0	32.9	24.9%

Table F5. Humidity variations observed when testing in Compost Queens static heap compost, compared to values obtained from the handheld thermometer.

DHT22 sensor [% RH]	Handheld Probe [%]	Absolute Error [% RH]	Percent Error [%]
56.0	95.0	39.0	41.1%
55.5	98.0	42.5	43.4%
55.8	100.0	44.2	44.2%
55.7	100.0	44.3	44.3%
55.4	90.0	34.6	38.4%
56.6	95.0	38.4	40.4%

Table F6. DFRobot Gravity I^2C oxygen sensor variations from standard ambient oxygen volume concentration.

Gravity I2C Oxygen Sensor [%]	Ambient Conditions [% vol.]	Absolute Error [%]	Percent Error [%]
21.68	21.00	0.68	3.24%
21.71	21.00	0.71	3.38%
21.74	21.00	0.74	3.52%
21.71	21.00	0.71	3.38%
21.86	21.00	0.86	4.10%
21.89	21.00	0.89	4.24%

Appendix G: Second round of sensor testing with Compost Queen covered static heap bins



Figure G1. Uncovered handheld probes used for control measurements placed at the top of the compost.



Figure G2. Burying probe under ~3 feet of compost to assess waterproofing and durability of the sensors contained within the capsule as they are exposed to the compost environment.



Figure G3. Reading out sensor values from the serial monitor while the peripheral device was covered with mass of compost.



Figure G4. Placing additional pressure on the mass of compost above the sensor capsule while temperature, humidity, and oxygen levels are recorded



Figure G5. Results of humidity testing at Compost Queens - view of humidity test strip results after capsule was removed from compost. This strip was placed adjacent to where the microcontroller was resting.



Figure G6. Results of humidity testing - view of test strip placed in the end cap membrane of the device where the sensors rest and are exposed to the ambient environment.

Appendix H: Humidity Test Results

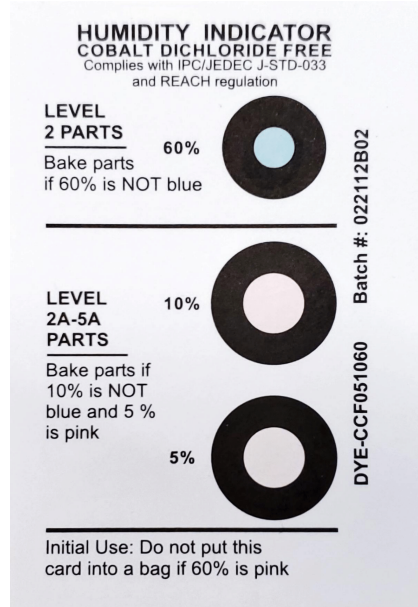

Figure H1. Humidity indicator for the humidity test strips that test results were based on.

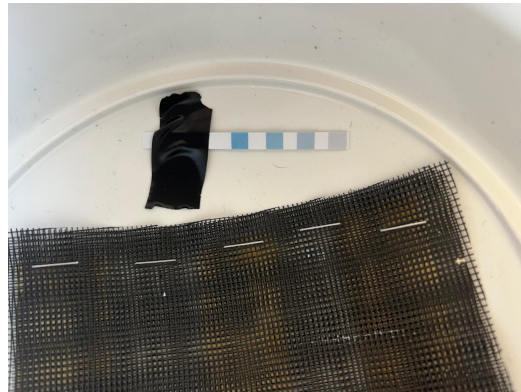

Figure H2. Humidity test strip in the removable end cap with four drilled holes, showing about a 30% humidity.



Figure H3. Test strip on the last acrylic membrane near the mesh covering showing about 30% humidity.

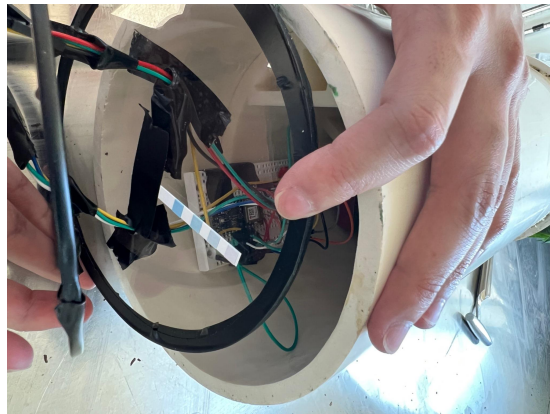

Figure H4. Humidity test strip between two acrylic membranes showing about 30% humidity.



Figure H5. Humidity test strip that was inside with the electronics showing about 15% humidity.



Figure H6. Control humidity test strip that was placed in the compost showing approximately 80% humidity.

Appendix I: Instruments used for yearlong compost measurements and for nominal values



Figure I1. Dial Pocket Soil Thermometer



Figure I2. 3-in-1 Soil Moisture/ Light/ pH Tester



Figure I3. Hand-Held gas meter similar to the one used for nominal oxygen concentration values in the first round of sensor testing.

Appendix J: Electrical wiring schematics

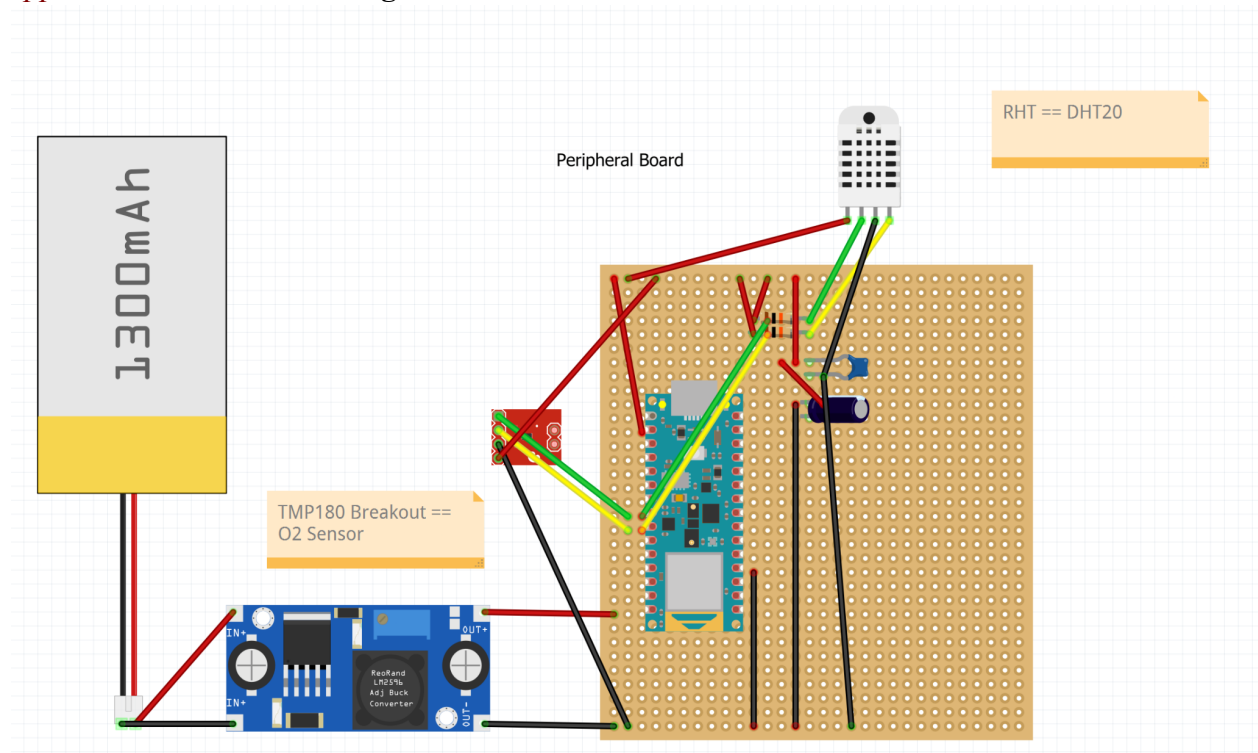

Figure J1. Perf board schematic of the peripheral microcontroller electronics. Sensors implemented in the physical prototype are represented by equivalent sensors in the schematic. Battery and buck converter are generic representations of the components used in our design since they were not supported by default in the Fritzing software.

Appendix K: Impact Testing



Figure K1. Unblemished sensor capsule prior to impact testing (left) **Figure K2.** Test setup for the 0.61 m drop (right).

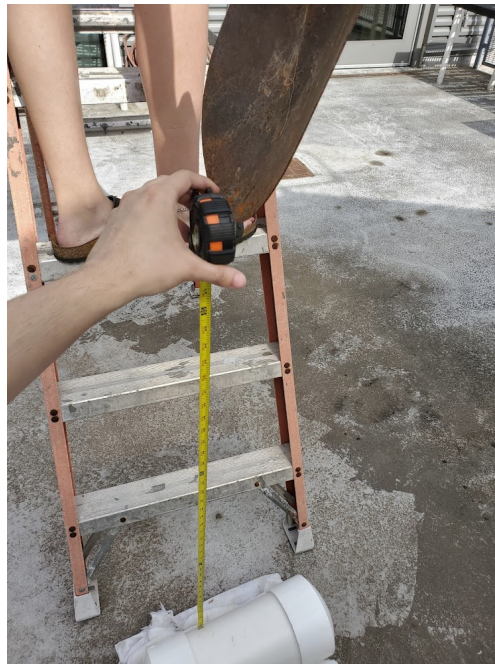

Figure K3. Test setup with drop height of 1 meter.

Appendix L: Bluetooth Range Test Results

Table L1. BLE test results with distance between devices

Distance between sensors (cm)	T1 (dBm)	T2 (dBm)	T3 (dBm)	T4 (dBm)	T5 (dBm)	T6 (dBm)	T7 (dBm)
55.9 cm	-80	-80	-79	-73	-80	-70	-73
147 cm	-72	-75	-84	-75	-83	-73	-81
270 cm	-73	-71	-71	-71	-72	-73	-70
420 cm	N/a	N/a	N/a	N/a	N/a	N/a	N/a

Table L2. Continuation of BLE test results with distance between devices

Distance between sensors (cm)	T8 (dBm)	T9 (dBm)	T10 (dBm)	T11 (dBm)	T12 (dBm)	T13 (dBm)	T14 (dBm)	T15 (dBm)
55.9 cm	-81	-78	-80	-74	-77	-80	-81	-64
147 cm	-76	-84	-79	-87	-83	-83	-82	-73
270 cm	-71	-79	-71	-79	-78	-82	-80	-69
420 cm	N/a	N/a	N/a	N/a	N/a	N/a	N/a	N/a

Table L3. BLE test results inside team's active composting unit

Distance between sensors (cm)	T1 (dBm)	T2 (dBm)	T3 (dBm)	T4 (dBm)	T5 (dBm)	T6 (dBm)	T7 (dBm)
55.9 cm	-76	-84	-84	-84	-81	-82	-87
147 cm	-87	-83	-82	-82	-84	-85	-84
270 cm	N/a	N/a	N/a	N/a	N/a	N/a	N/a

Table L4. Continuation of results from inside team's active composting unit

Distance between sensors (cm)	T8 (dBm)	T9 (dBm)	T10 (dBm)	T11 (dBm)	T12 (dBm)	T13 (dBm)	T14 (dBm)	T15 (dBm)
55.9 cm	-74	-83	-84	-78	-74	-77	-81	-82
147 cm	-88	-86	-86	-84	-84	-84	-86	-87
270 cm	N/a	N/a	N/a	N/a	N/a	N/a	N/a	N/a

Appendix M: Graphical diagrams for software data flow

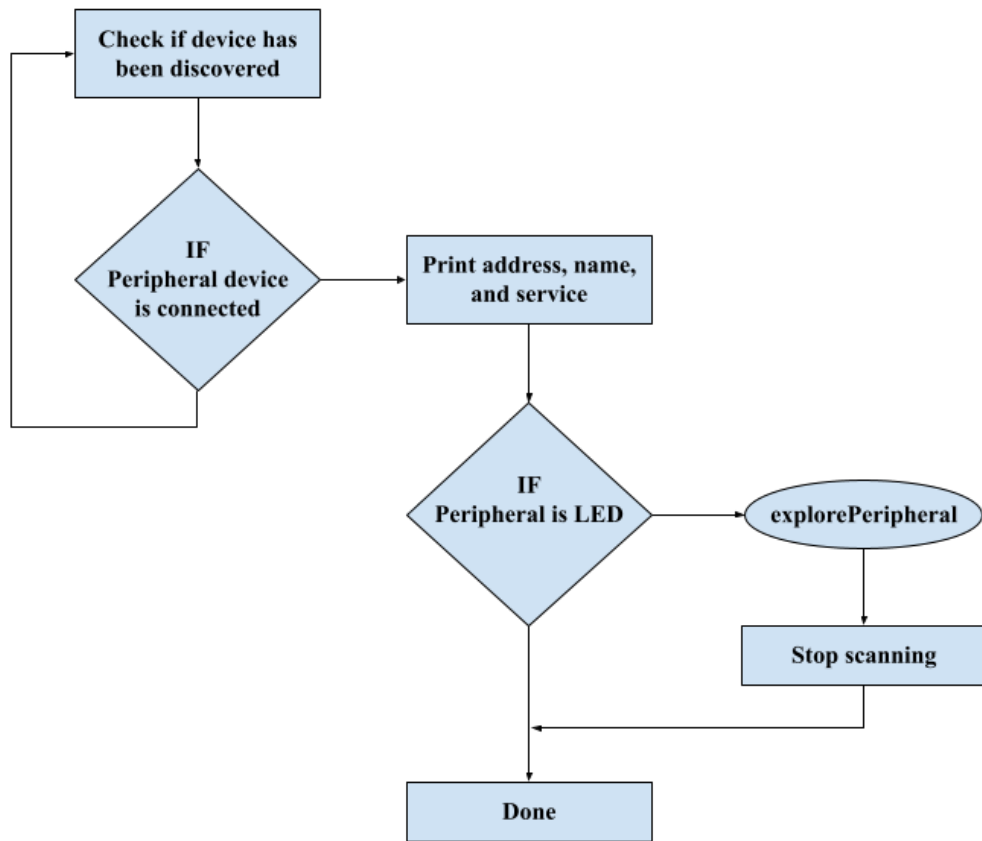

Figure M1. Flowchart for Central Unit code

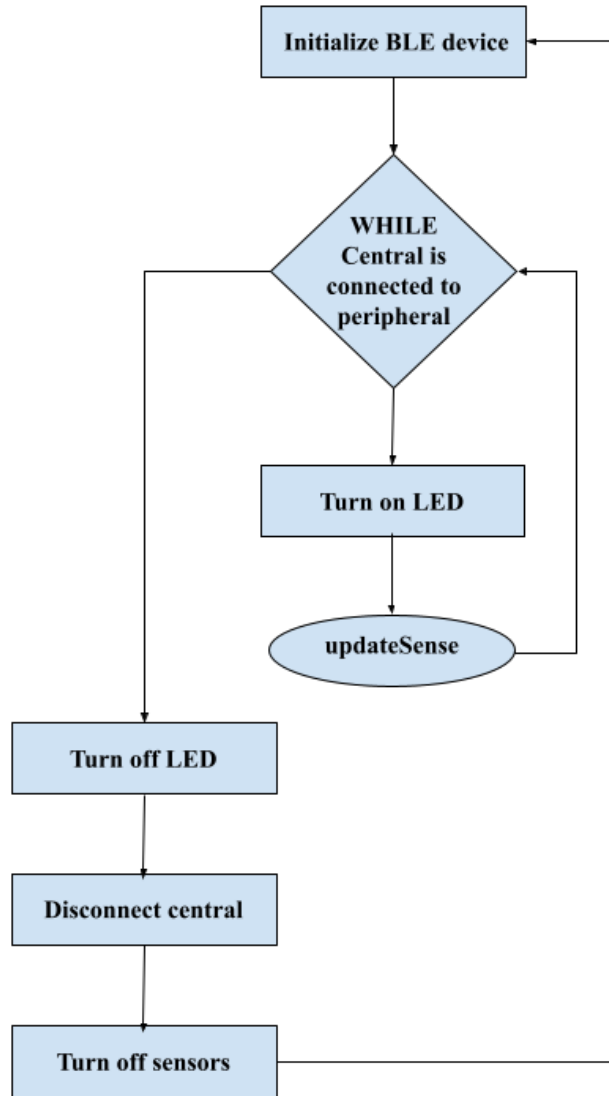

Figure M2. Flowchart for Peripheral device code

Appendix N: Bill of Materials for Final Prototype

Table N1. Bill of Materials for Central Unit

Part Description	Cost	Manufacturer	Source
Arduino Nano 33 BLE	\$21.30	Arduino	Arduino
16x2 LCD	\$9.95	Adafruit	Adafruit
220Ω Resistor	\$0.10	Arrow Electronics	ArrowElectronics
Rotary Potentiometer - 10kΩ, Linear	\$0.76	TTI	TTI
Arduino Uno Rev3	\$24.20	Arduino	Arduino
USB micro-B Cable - 6'	\$5.50	Sparkfun	Sparkfun
USB 2.0 Cable Type A/B	\$6.70	Arduino	Arduino
Jumper Wires Pack - M/M	\$2.10	Sparkfun	Sparkfun
3mm Plywood Box	\$12.72	Anderson Plywood	Amazon

Table N2. Bill of Materials for Peripheral Unit

Part Description	Cost	Manufacturer	Source
Arduino Nano 33 BLE	\$21.30	Arduino	Arduino
12V 10Ah Battery	\$99.00	Dakota Lithium	DakotaLithium
12V 3A LiFePO4 Battery Charger	\$29.00	Dakota Lithium	Dakota Lithium
XWST DC DC 12V 24V to 5V Converter 1A	\$5.29	XWST	Aliexpress
DHT20 Temperature & Humidity Sensor - I^2C	\$6.50	TinyTronics	TinyTronics
10kΩ Resistor	\$0.10	Arrow Electronics	ArrowElectronics
100 nF Capacitor	\$0.64	Arrow Electronics	ArrowElectronics
10 μF Decoupling Capacitor	\$0.27	Arrow Electronics	ArrowElectronics
Gravity: I^2C Oxygen Sensor	\$53.90	DFRobot	DFRobot
~1' x 6" PVC	\$77.92	Lowe's	Lowe's
6" PVC End Caps	\$40.56	Lowe's	Lowe's
Jumper Wires Pack - M/M	\$2.10	Sparkfun	Sparkfun

IEEE References

- [1] “Compost Fundamentals,” *Compost fundamentals: Compost needs - temperature*. [Online]. Available: http://whatcom.wsu.edu/ag/compost/fundamentals/needs_temperature.htm. [Accessed: 19-Nov-2021].
- [2] T. A. Team, “Connecting Nano 33 BLE devices over Bluetooth®: Arduino documentation,” *Arduino Documentation | Arduino Documentation*. [Online]. Available: <https://docs.arduino.cc/tutorials/nano-33-ble-sense/ble-device-to-device>. [Accessed: 02-Dec-2021].
- [3] T. A. Team, “Getting started with the Arduino Nano 33 ble,” *Arduino*. [Online]. Available: <https://www.arduino.cc/en/Guide/NANO33BLE>. [Accessed: 02-Dec-2021].
- [4] “Carry on composting ~ anaerobic digestion and composting,” *Carry on Composting*, 03-May-2022. [Online]. Available: <http://www.carryoncomposting.com/142941479>. [Accessed: 03-May-2022].
- [5] A. Industries, “PM2.5 Air Quality Sensor with I2C interface - PMSA003I,” *adafruit industries blog RSS*. [Online]. Available: <https://www.adafruit.com/product/4505>. [Accessed: 03-May-2022].
- [6] “6.89US \$: XWST DC DC 12V 24V to 5V voltage converter 1A 2A 3A 5A 10a 15a 20a 25a 30a 40a step up down Buck 5V voltage reducer - inverters & converters - aliexpress,” *aliexpress.com*. [Online]. Available: <https://www.aliexpress.com/item/2255800591167203.html?gatewayAdapt=4itemAdapt>. [Accessed: 03-May-2022].
- [7] “Data sheet dht20 humidityandtemperaturemodule ...” [Online]. Available: <https://cdn.sparkfun.com/assets/8/a/1/5/0/DHT20.pdf>. [Accessed: 03-May-2022].
- [8] “Digital-output relative humidity & temperature sensor/module DHT22 ...” [Online]. Available: <https://www.sparkfun.com/datasheets/Sensors/Temperature/DHT22.pdf>. [Accessed: 03-May-2022].
- [9] *DFRobot gravity: I2C Oxygen Sensor*. [Online]. Available: https://wiki.dfrobot.com/Gravity_I2C_Oxygen_Sensor_SKU_SEN0322. [Accessed: 03-May-2022].
- [10] “Liquid electrical tape,” *Star brite*. [Online]. Available: <http://www.starbrite.com/category/liquid-electrical-tape>. [Accessed: 03-May-2022].
- [11] “How to measure the power consumption of a circuit,” *How to Measure the Power Consumption of a Circuit*, 17-Mar-2022. [Online]. Available: <https://resources.pcb.cadence.com/blog/2021-how-to-measure-the-power-consumption-of-a-circuit>. [Accessed: 03-May-2022].

- [12] “Gammonpower.com,” *GammonPower.com*. [Online]. Available: <http://www.gammonpower.com/>. [Accessed: 03-May-2022].
- [13] “How to reduce power consumption on the nano 33 ble - arduino.” [Online]. Available: <https://support.arduino.cc/hc/en-us/articles/4402394378770-How-to-reduce-power-consumption-on-the-Nano-33-BLE>. [Accessed: 03-May-2022].
- [14] “Article Versions Notes,” *Sensors | Free Full-Text | Cave Pearl Data Logger: A Flexible Arduino-Based Logging Platform for Long-Term Monitoring in Harsh Environments | Notes*. [Online]. Available: <https://www.mdpi.com/1424-8220/18/2/530/notes>. [Accessed: 03-May-2022].
- [15] “Arduinoble,” *ArduinoBLE - Arduino Reference*. [Online]. Available: <https://www.arduino.cc/reference/en/libraries/arduinoble/>. [Accessed: 05-May-2022].
- [16] M. Afaneh and M. Afaneh, “The basics of Bluetooth Low Energy (BLE),” *Novel Bits*, 18-Apr-2022. [Online]. Available: <https://www.novelbits.io/basics-bluetooth-low-energy/>. [Accessed: 05-May-2022].
- [17] *Troubleshooting*. [Online]. Available: <http://compost.css.cornell.edu/Factsheets/FS10.html>. [Accessed: 05-May-2022].
- [18] *Troubleshooting composting problems*. [Online]. Available: <http://compost.css.cornell.edu/trouble.html>. [Accessed: 05-May-2022].
- [19] *Oxygen*. [Online]. Available: <http://compost.css.cornell.edu/Factsheets/FS4.html>. [Accessed: 05-May-2022].
- [20] *Monitoring compost Ph - Cornell composting*. [Online]. Available: <http://compost.css.cornell.edu/monitor/monitorph.html>. [Accessed: 05-May-2022].
- [21] “12V batteries,” *Dakota Lithium Batteries*. [Online]. Available: <https://dakotalithium.com/product-category/12v-lithium-batteries/>. [Accessed: 05-May-2022].
- [22] *Temperature*. [Online]. Available: <http://compost.css.cornell.edu/Factsheets/FS5.html>. [Accessed: 05-May-2022].
- [23] “Arduino Nano 33 ble,” *Arduino Online Shop*. [Online]. Available: <http://store-usa.arduino.cc/products/arduino-nano-33-ble>. [Accessed: 05-May-2022].
- [24] “Atmospheric oxygen,” *Atmospheric oxygen - Energy Education*. [Online]. Available: https://energyeducation.ca/encyclopedia/Atmospheric_oxygen. [Accessed: 05-May-2022].
- [25] A. Industries, “Raspberry pi 2 - model B v1.2 - ARM cortex-A53 with 1G RAM,” *adafruit industries blog RSS*. [Online]. Available: <https://www.adafruit.com/product/2358?src=raspberrypi>. [Accessed: 05-May-2022].

- [26] A. Industries, “Adalogger featherwing - RTC + SD add-on for all feather boards,” *adafruit industries blog RSS*. [Online]. Available: <https://www.adafruit.com/product/2922>. [Accessed: 05-May-2022].
- [27] “How to send sensor data to cloud using NODMCU8266,” *Hackaday.io*. [Online]. Available: <https://hackaday.io/project/173242-how-to-send-sensor-data-to-cloud-using-nodmcu8266>. [Accessed: 05-May-2022].
- [28] “Remote Environment Controller for Extreme Experiments,” *Arduino Project Hub*. [Online]. Available: <https://create.arduino.cc/projecthub/biomaker-challenge-2017-team-27/remote-environment-controller-for-extreme-experiments-cb0ca3>. [Accessed: 05-May-2022].
- [29] S. Asad, *Best temperature and humidity sensor modules for Arduino*, 01-Jan-1968. [Online]. Available: https://linuxhint.com/temperature_and_humidity_sensor_modules_for_arduino/. [Accessed: 05-May-2022].
- [30] “Standard volume-to-weight conversion factors - epa.gov.” [Online]. Available: <https://www.epa.gov/sites/default/files/2016-03/documents/conversions.pdf>. [Accessed: 06-May-2022].
- [31] “Code 317 (NO) - USDA.” [Online]. Available: https://efotg.sc.egov.usda.gov/api/CPSFile/14745/317_NC_CPS_Composting_Facility_2017. [Accessed: 06-May-2022].
- [32] “IEC 60529 Ingress Protection Expertise,” *CVG Strategy*, 10-Nov-2020. [Online]. Available: <https://cvgstrategy.com/iec-60529/>. [Accessed: 06-May-2022].
- [33] “Composites: Material Datasheet.” *Markforged*, <http://static.markforged.com/downloads/composites-data-sheet.pdf>
- [34] “Compost troubleshooting your compost - cornell cooperative extension.” [Online]. Available: <http://ccetompkins.org/resources/compost-troubleshooting-your-compost>. [Accessed: 07-May-2022].
- [35] *The Science and Engineering of Composting*. [Online]. Available: <http://compost.css.cornell.edu/science.html>. [Accessed: 06-May-2022].
- [36] A. Ghosh and About Abhishek Ghosh Abhishek Ghosh is a Businessman, “Note on calculating distance from RSSI value of BLE devices,” *The Customize Windows*, 18-Mar-2020. [Online]. Available: <https://thecustomizewindows.com/2020/03/note-on-calculating-distance-from-rssi-value-of-ble-devices/>. [Accessed: 08-May-2022].

[37] Hymcode, “Calculating Total Arduino power consumption,” *Arduino Forum*, 29-Dec-2017. [Online]. Available: <https://forum.arduino.cc/t/calculating-total-arduino-power-consumption/499262>. [Accessed: 08-May-2022].

[38] “Tracer 12V 4Ah Lithium Polymer Battery Pack,” *Tracer*. [Online]. Available: <https://www.tracerpowers.com/12v-4ah-lithium-polymer-battery-pack.html>. [Accessed: 08-May-2022].