



(51) International Patent Classification:
G01N 33/24 (2006.01)

(21) International Application Number:
PCT/IB20 19/055 142

(22) International Filing Date:
19 June 2019 (19.06.2019)

(25) Filing Language: Italian

(26) Publication Language: English

(30) Priority Data:
102018000006477 20 June 2018 (20.06.2018) IT

(71) Applicant: UNIVERSITA' DI PISA [IT/IT]; Lungarno Pacinotti 43/44, 56126 Pisa (IT).

(72) Inventor: RALLO, Giovanni; Via F. da Buti 28, 56125 Pisa (IT).

(74) Agent: GERBINO, Angelo et al.; c/o Jacobacci & Partners S.p.A., Corso Emilia 8, 10152 Torino (IT).

(81) Designated States (unless otherwise indicated, for every kind of national protection available): AE, AG, AL, AM, AO, AT, AU, AZ, BA, BB, BG, BH, BN, BR, BW, BY, BZ, CA, CH, CL, CN, CO, CR, CU, CZ, DE, DJ, DK, DM, DO, DZ, EC, EE, EG, ES, FI, GB, GD, GE, GH, GM, GT, HN, HR, HU, ID, IL, IN, IR, IS, JO, JP, KE, KG, KH, KN, KP, KR, KW, KZ, LA, LC, LK, LR, LS, LU, LY, MA, MD, ME,

MG, MK, MN, MW, MX, MY, MZ, NA, NG, NI, NO, NZ, OM, PA, PE, PG, PH, PL, PT, QA, RO, RS, RU, RW, SA, SC, SD, SE, SG, SK, SL, SM, ST, SV, SY, TH, TJ, TM, TN, TR, TT, TZ, UA, UG, US, UZ, VC, VN, ZA, ZM, ZW.

(84) Designated States (unless otherwise indicated, for every kind of regional protection available): ARIPO (BW, GH, GM, KE, LR, LS, MW, MZ, NA, RW, SD, SL, ST, SZ, TZ, UG, ZM, ZW), Eurasian (AM, AZ, BY, KG, KZ, RU, TJ, TM), European (AL, AT, BE, BG, CH, CY, CZ, DE, DK, EE, ES, FI, FR, GB, GR, HR, HU, IE, IS, IT, LT, LU, LV, MC, MK, MT, NL, NO, PL, PT, RO, RS, SE, SI, SK, SM, TR), OAPI (BF, BJ, CF, CG, CI, CM, GA, GN, GQ, GW, KM, ML, MR, NE, SN, TD, TG).

Declarations under Rule 4.17:

- as to applicant's entitlement to apply for and be granted a patent (Rule 4.17(H))
- of inventorship (Rule 4.17(iv))

Published:

- with international search report (Art. 21(3))



WO 2019/244057 A1

(54) Title: SYSTEM FOR THE DETERMINATION OF THE REAL EVAPOTRANSPIRATION OF A VEGETATED SURFACE

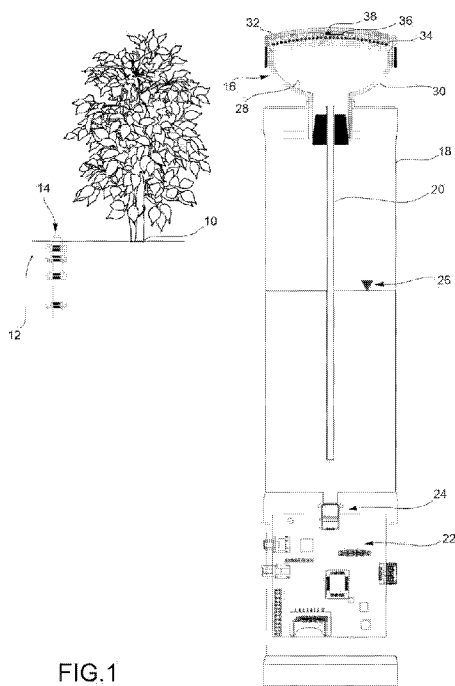

FIG.1

(57) Abstract: A device for determining the real evapotranspiration of a vegetated surface (10) of a soil (12), comprises: a porous composite evaporator (16), at least a portion of which has a resistance to the water vapor flow which depends on a parameter, the evaporator (16) having an upper surface exposed to the atmosphere; a tank (18) of liquid water underlying the evaporator to which it is connected by a suction tube (20), and provided with a level (26) meter (24); a sensor (14) for measuring the humidity value of the soil (12); and a CPU (22) which controls the parameter on which the resistance to the water flow vapor through the evaporator depends, depending on the humidity value of the soil (12) detected by the sensor (14).

**SYSTEM FOR THE DETERMINATION OF THE REAL EVAPOTRANSPIRATION OF
A VEGETATED SURFACE**

The present invention relates to a device for determining the real evapotranspiration (ET_r) of a natural or cultivated vegetated surface.

A known system for determining evapotranspiration involves the use of an atmometer comprising an element that simulates vegetation, consisting of a double fabric permeable to vapor and impermeable to water in the liquid state and interposed between a porous plate which simulates a soil constantly irrigated and the atmosphere. This fabric constitutes a rigid porous medium with fixed permeance to the water vapor and analogous to the maximum stomatal one of the plants that constitutes the reference lawn.

Such a system then calculates the ET_0 , or the reference evapotranspiration from which the ET_r can be traced back using tabulated crop coefficients, appropriately adjusted to take into account the different conditions of air humidity and windiness with respect to the area where the tabulated values have been obtained experimentally. The use of additional adjustment coefficients is necessary when the water conditions of soil are different from the potential ones. The determination is therefore rather laborious and subject to inaccuracies due to the wide use of empirical coefficients.

Furthermore, systems are known which measure the water exchanges of a vegetated surface by using micrometeorological technologies, namely "eddy covariance" towers and scintillometers.

US 2010/212 409 A1 describes an atmometer comprising an evaporator having an upper surface exposed to the atmosphere, a liquid water tank provided with a level meter and underlying the evaporator to which it is connected by a suction tube, a measurement sensor of the soil humidity value, and a CPU which controls the flow of water vapor through the evaporator depending on the soil humidity value.

An object of the present invention is to provide a device for determining the real evapotranspiration of the vegetated surface of a soil, improved with respect to those

described by the prior art.

According to the invention, this object is achieved with a device comprising:

- a composite porous evaporator, at least a portion of which has a resistance to the flow of water vapor that depends on a parameter, said evaporator having an upper surface exposed to the atmosphere,
- a tank of liquid water underlying the evaporator to which it is connected by a suction tube, and provided with a level meter,
- a sensor for measuring the soil humidity, and
- a central processing unit (CPU) which is configured to control said parameter on which the resistance to the flow of water vapor through the evaporator depends, in dependence on the humidity value of the soil detected by said sensor.

Preferred features of the device of the invention are described in the following claims depending on claim 1.

A further subject-matter of the present invention is a process for determining the real evapotranspiration by using the aforementioned device, as indicated in the process claims which follow.

An essential aspect of the device of the invention is the ability to vary the resistance, that is, its inverse, i.e. the permeance, to the flow of water vapor through the evaporator depending on the water state of the soil. In this way, the flow of water vapor coming out of the device, which is calculated starting from the decrease in the level of water in the tank, constitutes a very reliable approximation of the real evapotranspiration of the vegetated surface of the soil, which depends on its water state, in addition to the atmospheric conditions to which the upper surface of the evaporator is exposed similarly to the soil.

Typically, the controlled parameter on which the resistance/permeance to the water vapor flow through the evaporator depend is the temperature, which in turn is preferably regulated by the generation of heat by a resistor forming part of an electrical circuit inserted in the evaporator and controlled by the CPU.

Other parameters that can be controlled alternatively or in addition to the temperature are of a geometric nature, such as for example the thickness of the evaporator and/or the presence of gaps between the constitutive layers thereof.

The device and the process of the invention, which are based on real measurements, therefore have the advantage of minimizing, if not canceling, the use of tabulated crop coefficients, which must be subsequently corrected.

The device of the invention is also less cumbersome and expensive, as well as simpler from the point of view of the electrical and computational scheme, than known systems based on micrometeorological technologies.

Further advantages and features of the present invention will become apparent from the following detailed description, given by of a non-limiting example with reference to the accompanying drawing, in which:

figure 1 is a schematic representation of a device of the invention.

A device for determining the real evapotranspiration of a vegetated surface 10 of a soil 12, comprises a sensor 14 for measuring the humidity of the soil 12, a porous evaporator 16, a tank 18 of liquid water underlying the evaporator 16 to which it is connected by a suction tube 20, and a control CPU 22.

The tank 18 kept in depression to allow the water to rise through the tube 20 towards the evaporator 16, is provided with a water level meter 24, the measured values whereby are transmitted to the CPU 22.

The evaporator 16 has a composite structure comprising a lower plate 28 of ceramic material enclosed by a waterproofed ceramic capsule 30, an upper layer 32 of fabric exposed to the atmosphere and having a color and albedo corresponding to those of the vegetated surface, and an intermediate layer 34 having resistance to the water vapor flow which depends on the temperature parameter.

Preferably, the upper layer 32 is Green Canvas acrylic fabric produced by Sunbrella Fabrics (183 1 N. Park Avenue Glen Raven, NC, USA), green Erin color and albedo of about 0.2.

Advantageously, the intermediate layer 34 is of a fabric which incorporates shape memory polymeric material which varies its geometry following the variation of a thermal parameter such as temperature. Preferably, such shape memory polymeric material is poly-NiPAAm/chitosan microgel.

In the intermediate layer 34 a resistor 36 is embedded which is part of an electrical circuit (not shown in the diagram of figure 1) and whose heat generation is controlled by the CPU 22 on the basis of the temperature values of the intermediate layer 34 detected by a sensor, such as a thermocouple 38.

A process for determining the real evapotranspiration of the vegetated soil surface by using the aforementioned device installed therein is now described.

Liquid water previously fed into the tank 18 is suctioned through the tube 20 into the evaporator 16. Crossing the latter, the water vaporizes and finally passes into the atmosphere exiting from the upper layer 32. Thanks to the level measurements 26 performed by the meter 24, the CPU 22 is able to calculate the decrease in the quantity of water present in the tank 18, which corresponds to the vaporized quantity. The CPU 22 is also able to control the resistance, or rather its inverse, i.e. the permeance, to the vapor flow of the intermediate layer 34 of the evaporator 16 depending on the humidity value of the soil 12 measured by the sensor 14, in a manner such that the calculated flow of vaporized water, or the quantity of vapor flowing in the unit of time through the surface unit, substantially corresponds to the flow of evapotranspiration which actually takes place through the vegetated surface 10 of the soil 12 and which is therefore estimated by the device in a suitably accurate manner.

In particular, the more the soil 12 is wet, the more the resistance to the vapor flow of the

evaporator 16 is decreased, while the more the soil 12 is dry the more the resistance to the vapor flow of the evaporator 16 is increased.

For this purpose, the fact that the resistance/permeance to the water vapor flow of the intermediate layer 34 of the evaporator 16 depends on its temperature is exploited. Therefore, the CPU 22 controls the latter parameter, so as to cause the evaporator 16 to assume the desired value of resistance/permeance to the vapor flow at a given rate of humidity of the soil 12.

Specifically, the temperature is controlled by the CPU 22 by regulating the generation of heat by the resistor 36 based on the temperature values detected by the thermocouple 38, according to well-known principles of system thermal regulation. For example, if the detected temperature is lower than the desired one, heat generation is increased by increasing the intensity of electric current flowing through the resistor and/or the resistance of the latter, or vice versa, so as to compensate for the deviation of the temperature parameter from the desired value.

Of course, the principle of the invention being unchanged, the details of construction and the embodiments may widely vary with respect to what has been described purely by way of example, without thereby departing from the scope of the invention as defined in the appended claims.

In particular, any "thermally-driven" fabric could be used as constitutive of the intermediate layer of the evaporator, in which the temperature induced through a thermoresistor causes the permeance to vary due to the vapor flow as it exceeds the so-called activation temperature of the constitutive shape-memory polymers. Also porous membranes based on nano-polyurethane fibers sensitive to thermal stimuli belong to this category of fabrics, which are inserted through electrospinning and laid therein (Charly Azra et al., 2015; Mondal et al., 2006). Such polymers in particular have a permeability to water vapor variable in a representative domain of the main agricultural crops, and in particular $<1000 \text{ g}\cdot\text{m}^{-2}\cdot\text{d}^{-1}$, which corresponds to a stomatal resistance of about $100 \text{ s}\cdot\text{m}^{-1}$.

It is also possible to use as constitutive materials of the intermediate layer of the evaporator polymers which can be activated through low-power electrical stimuli, thus avoiding the generation of heat and the consequent alteration of the heat balance in the area of the device affected by the water exchange process: in fact, one thermal stimulus, different from the environmental one, modifies the water state and therefore the natural vapor concentration gradient of the system.

Such a stimulus is for example represented by a voltage difference which does not cause the material to heat up, but causes its porosity to vary in combination with the thickness of the material itself. A combined variation of porosity and thickness results in a variation of the tortuosity, much more effective than the variation of porosity alone in order to influence the resistance to the water vapor flow.

Furthermore, the controlled creation of a gap between the porous plate and the intermediate layer of the evaporator allows controlling the global permeance of the device also through this way.

For this purpose, graphene actuators or actuators based on polythiophene gels capable of converting an electrical stimulus into mechanical energy can be used, so as to generate a gap between the porous plate and the intermediate layer of the evaporator, varying the resistance to the water vapor flow.

CLAIMS

1. Device for the determination of the real evapotranspiration of a vegetated surface (10) of a soil (12), comprising:
 - a composite porous evaporator (16), at least a portion of which has a resistance to the flow of water vapor that depends on a parameter, said evaporator (16) having an upper surface exposed to the atmosphere,
 - a tank (18) of liquid water underlying the evaporator to which it is connected by a suction tube (20), and provided with a level (26) meter (24),
 - a sensor (14) for measuring the soil (12) humidity value, and
 - a CPU (22) which controls said parameter on which the resistance to the flow of water vapor through the evaporator depends, in dependence on the humidity value of the soil (12) detected by said sensor (14).

2. Device according to claim 1, wherein said evaporator (16) comprises a lower plate (28) of ceramic material, an upper layer (32) of fabric exposed to the atmosphere, and an intermediate layer (34) having resistance to the water vapor flow which depends on the temperature parameter, and wherein a resistor (36) is embedded, that is part of an electric circuit which is controlled by said CPU (22) which establishes, by heat generation of said resistor (36), the temperature of the evaporator (16) parameter, and consequently the water vapor flow that passes through it, in dependence on the humidity value of the soil (12) detected by said sensor (14).

3. Device according to claim 2, in which the intermediate layer (34) is made of a fabric which incorporates a shape-memory polymeric material which varies its geometry as a result of the variation in temperature.

4. Device according to claim 3, wherein said shape memory polymeric material is a poly-NiPAAm/chitosan microgel.

5. Device according to any one of the preceding claims, wherein said upper surface of the evaporator (16) has color and albedo substantially similar to those of the vegetated

surface (10).

6. Device according to any one of the preceding claims, wherein said parameter is the temperature of the evaporator (16).

7. Device according to claim 6, wherein a temperature sensor, such as a thermocouple (38), detects the temperature value of the evaporator (16), and transmits it to said CPU (22).

8. Process for the determination of the real evapotranspiration of a vegetated surface (10) of a soil (12) by means of a device according to any one of the preceding claims, wherein said evapotranspiration is calculated by the CPU (22) starting from the decrease in the level (26) of the water in the tank (18) detected by the meter (24), which decrease is an index of the flow of water vapor through the evaporator (16) which has a resistance to the flow of water vapor dependent on a parameter which is controlled by the CPU (22) in dependence on the soil humidity value (12) detected by the sensor (14).

9. Process according to claim 8, wherein said parameter is the temperature of the evaporator (16).

10. Process according to claim 9, wherein the temperature of the evaporator (16) is established by heat generation of a resistor embedded in said evaporator (16) and being part of an electric circuit controlled by the CPU (22).

11. Process according to claim 10, wherein the control action of the CPU (22) takes place on the basis of the temperature values of the evaporator (16) detected by a sensor, such as a thermocouple (38).

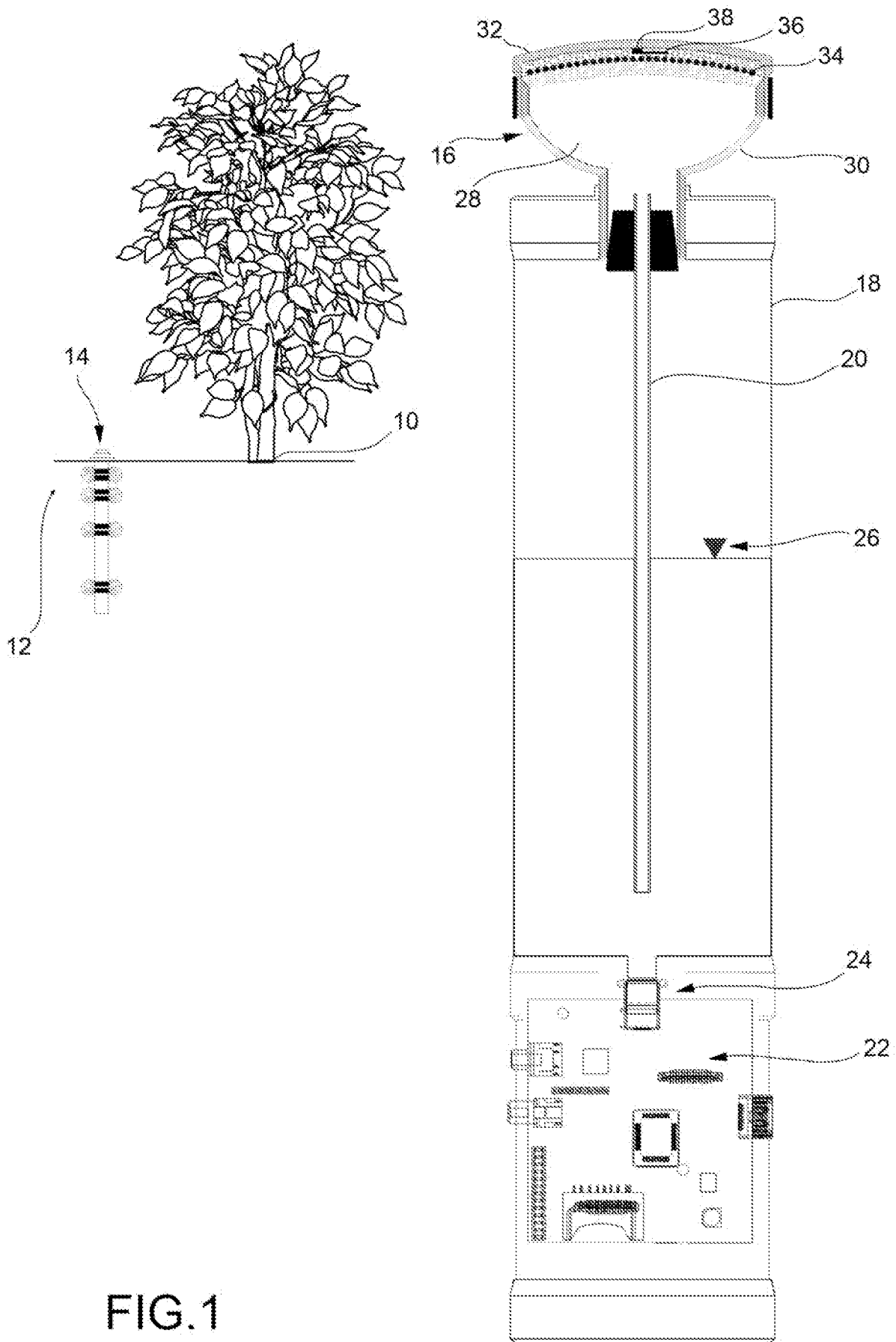

INTERNATIONAL SEARCH REPORT

International application No
PCT/IB2019/055142

A. CLASSIFICATION OF SUBJECT MATTER INV. G01N33/24 ADD.		
According to International Patent Classification (IPC) or to both national classification and IPC		
B. FIELDS SEARCHED		
Minimum documentation searched (classification system followed by classification symbols) G01N		
Documentation searched other than minimum documentation to the extent that such documents are included in the fields searched		
Electronic data base consulted during the international search (name of data base and, where practicable, search terms used) EPO-Internal		
C. DOCUMENTS CONSIDERED TO BE RELEVANT		
Category*	Citation of document, with indication, where appropriate, of the relevant passages	Relevant to claim No.
A	US 2010/212409 A1 (RANJAN RAMANATHAN SRI [CA]) 26 August 2010 (2010-08-26) cited in the application paragraphs [0038] - [0047]; figure 2 -----	1-11
A	CN 101 598 587 A (UNIV BEIJING NORMAL [CN]) 9 December 2009 (2009-12-09) page 5; figure	1-11
A	SEIKO OSOZAWA ET AL: "Improved Evaporimeter for Measuring Potential Evaporation from Field Soils", SOIL SCIENCE AND PLANT NUTRITION, vol. 33, no. 4, December 1987 (1987-12), pages 531-538, XP055553985, ISSN: 0038-0768, DOI: 10.1080/00380768.1987.10557602 abstract; figure 1 -----	1-11
<input type="checkbox"/> Further documents are listed in the continuation of Box C. <input checked="" type="checkbox"/> See patent family annex.		
* Special categories of cited documents :		
"A" document defining the general state of the art which is not considered to be of particular relevance "E" earlier application or patent but published on or after the international filing date "L" document which may throw doubts on priority claim(s) or which is cited to establish the publication date of another citation or other special reason (as specified) "O" document referring to an oral disclosure, use, exhibition or other means "P" document published prior to the international filing date but later than the priority date claimed		"T" later document published after the international filing date or priority date and not in conflict with the application but cited to understand the principle or theory underlying the invention "X" document of particular relevance; the claimed invention cannot be considered novel or cannot be considered to involve an inventive step when the document is taken alone "Y" document of particular relevance; the claimed invention cannot be considered to involve an inventive step when the document is combined with one or more other such documents, such combination being obvious to a person skilled in the art "&" document member of the same patent family
Date of the actual completion of the international search <p align="center">20 August 2019</p>		Date of mailing of the international search report <p align="center">28/08/2019</p>
Name and mailing address of the ISA/ European Patent Office, P.B. 5818 Patentlaan 2 NL - 2280 HV Rijswijk Tel. (+31-70) 340-2040, Fax: (+31-70) 340-3016		Authorized officer <p align="center">Wilhelm-Shalغانov, J</p>

INTERNATIONAL SEARCH REPORT

Information on patent family members

International application No
PCT/IB2019/055142

Patent document cited in search report	Publication date	Patent family member(s)	Publication date
US 2010212409 A1	26-08-2010	CA 2694399 A1	25-08-2010
		US 2010212409 A1	26-08-2010

CN 101598587 A	09-12-2009	NONE	
