

# Application of a smart dynamic scale for measuring live-fish biomass in aquaculture

1<sup>st</sup> Lorenzo Rossi

Department of Veterinary Science –  
University of Pisa  
Viale delle Piagge, 2  
Pisa, Italy  
lorenzo.rossi@phd.unipi.it

4<sup>th</sup> Eugenio Damiano

MEGA Materials s.r.l.  
Largo Bruno Pontecorvo, 3  
Pisa, Italy  
e.damiano@megamaterials.it

2<sup>nd</sup> Carlo Bibbiani

Department of Veterinary Science –  
University of Pisa  
Viale delle Piagge, 2  
Pisa, Italy  
carlo.bibbiani@unipi.it

5<sup>th</sup> Alberto Di Lieto

Department of Physics – University of  
Pisa  
Largo Bruno Pontecorvo, 3  
Pisa, Italy  
alberto.di.lieto@unipi.it

3<sup>rd</sup> Baldassare Fronte

Department of Veterinary Science –  
University of Pisa  
Viale delle Piagge, 2  
Pisa, Italy  
baldassare.fronte@unipi.it

**Abstract**— The need of measuring the fish biomass, either for in-land facilities or offshore cages, drove recently to develop a cheap dynamic scale (by MEGA Materials srl), based on a board of the Arduino family, suitable to measure live-fish weights. Via a Bluetooth transmitter and a specific app the communication with smartphones is allowed. The estimation of live-fish biomass is extremely relevant to precisely quantify the daily dose of feed to be supplied and to avoid a reduction of fish growth. We present the comparison between ‘static’ and ‘dynamic’ weight measures of seabream juveniles reared in tanks.

**Index Terms**—aquaculture, sensors, biomass evaluation, fish production.

## I. INTRODUCTION

The World Global fish production is estimated to have reached about 179 million tonnes in 2018 [1], of which 82 million tonnes coming from aquaculture production. So far, aquaculture needs a technological support to specifically contribute further development in this sector. For instance, great results have been achieved in water monitoring through the implementation of Internet of Things (IoT) principles [2]. The application of technological innovations in aquaculture, could also improve resources utilization and reduce waste discharge during routine farm operations [3], [4]. Commercial aquafarms goals are to feed fish to maintain desired growth rates and keep feed loss to the environment at a minimum, especially in offshore farms. Moreover, feed cost accounts for about 40-50 percent of running costs and is thus the most significant expense in carnivorous fish production [4]. Since fish are commonly fed with a ratio of feed to fish biomass, aquaculture farmers should precisely quantify the fish biomass and thus the daily dose of feed to be supplied to avoid a reduced fish growth due to underfeeding or an environmental pollution and economic loss due to overfeeding [5], [6]. Moreover, estimating the live-fish biomass allows the comparison of the pen-specific

fish growth curve to the standard curve of the fish species, besides the determination of the specific feed conversion rate (FCR), which is an index that provides information about the efficiency of the used feed. Another relevant parameter to be monitored is the density within a pen to ensure fish welfare and suitable fish growth performances. This parameter is usually estimated by discrepancy between the initial number of fish and countable dead fish [5], [6]. Thus, the fish biomass of a rearing unit (i.e. cage, tank, etc.) can be estimated by multiplying the average weight by the number of fish at a specific time. However, manual sampling can cause physical damage or great stress to fish, and is also usually time-consuming, laborious and has an inherent inaccuracy of 15–25% [6]. For these reasons, during the last decades automated biomass monitoring and counting systems mostly based on machine vision, acoustics, environmental DNA, and resistivity counter tools have been set up [5], [7]. Nevertheless, they are oriented to medium-large fish size, needing many calibration points. Moreover, non-intrusive methods for fish biomass estimation are often affected by environmental conditions (e.g., turbidity of the water) [5]. Periodical weighing campaign remains the most widely used method for biomass estimation in commercial aquaculture. To this purpose, static or suspended scale (i.e., digital dynamometer, Figure 1) could be use. The weighing procedure in off-shore fish farms could be conducted on-land, transferring the fish with proper containers, or directly on-board. The on-board measuring in offshore aquafarms may be extremely difficult due to waves dynamics and ship motions [6].

A more efficient aquaculture activity relays on correct and rapid assessment of all the above-mentioned parameters to ensure the environmental sustainability of commercial intensive aquaculture. This study aims to preliminary test and validate the use of a simple, accurate, and reliable

dynamic weighing device comparing results against static weighing procedure.



Figure 1. On-board procedures for fish biomass monitoring. On the left side, the manual counting procedure; on the right the weighing procedure with a digital suspended scale. Pictures credit [6].

## II. INSTRUMENT DETAILS

A wide range of microcontrollers and sensors, in particular the popular boards of the *Arduino* family [8], capable of transferring data directly – or via simple communication chips – to microcontrollers. The communication is achieved using standard bus and protocols, like the I2C [9]. The I2C bus needs only two wires, reducing the complexity of connections for a small instrument, nevertheless allowing a single controller: i) to dialogue with up to 112 other addresses present in the bus structure; ii) to have a data transfer rate of 400 kbit/s; iii) to fulfill abundantly the requirements needed to develop a ‘dynamic’ weighing scale. Figure 2 shows the components of the scale. The device was designed and developed by MEGA Materials srl, an innovative spinoff of the Department of Physics of Pisa University.

The sensing element is a load cell based on a strain gauge in a Wheatstone bridge. The load cell is connected to a 24-bit analog-to-digital converter (ADC) designed for weigh scales based on bridge sensors, indicated in figure 2 as  $\Sigma\Delta$  Converter [10]. This ADC typically is capable of measuring the load cell in 50 ms, with a relative input noise voltage of a few  $10^{-6}$  parts, and a temperature drift less than 10 ppm/°C. This ADC is connected via the I2C bus to other ICs: the controller of the bus and a LCD display.

The controller of the bus – and the core of the instrument – is an Arduino-like board, based on a ATmega328 microcontroller [11]. Data can be displayed on the LCD display, sent via the USB or serial ports to an external computer, or to other devices via the Bluetooth transmitter/receiver.

A specific ‘App’ has been developed to allow the dialogue between the microcontroller and a smartphone. Commercially available LiPO rechargeable batteries have been used to power up the device.

A detailed description of the instrument is given in a previous publication [12].

## III. PROTOTYPING AND COMPARISON TESTS

### A. Prototype realization

A prototype to test the accuracy of the instrument was built. A load cell capable of measuring 1 kg (Readability 0.1 g; Weighing range max. 1000 g) was mounted in a 12 x 9.5 x 5.5 cm<sup>3</sup> enclosure together with all the required electronic components. The system was powered either by a regular 9V battery or via the USB connection used for debugging. A hook was secured to each side of the enclosure to hang the device and bare loads.

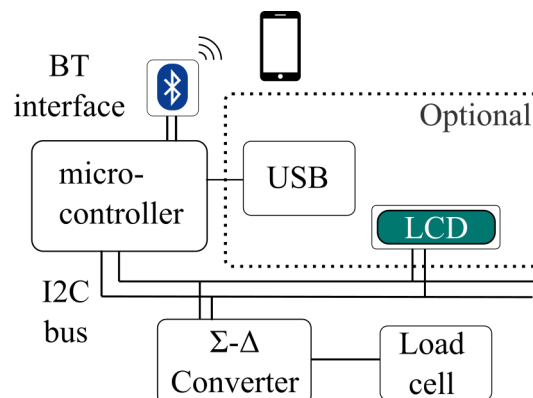

Figure 2. Scheme of the main components of the dynamic scale. Picture credit [13].

### B. Measuring procedure

The trial was conducted at the Department of Agriculture, Food, and Environment of the University of Pisa.

The calibration of the system was performed by attaching a bucket to the scale and placing masses of known weight into it. The microcontroller was programmed to return the raw ADC value resulting from an average of 25 readings (reading-time 1.2 s). A linear behavior of the device was observed by fitting the data, and the slope of the line was included in the code of the microcontroller as conversion value. Different load cells have of course different calibration values and a calibration is always required to ensure a correct reading, either factory- or final user-calibrated. Moreover, a self-calibration procedure can be implemented easily by programming the microcontroller unit. The instrument displays a remarkable stability in the dynamic case.

Figure 3 shows the procedures used in this trial to evaluate the efficacy of the dynamic scale compared to a static one.

The prototype dynamic scale takes measurements while oscillating loads are applied, such as live fish captured by a net. The average of the readings over a 8-second time-span corresponded to the ‘actual weight’ of the mass, setting an integration time of around 2 s. The dynamic scale is sustained by a chain from the upper hook, this feature allows us to simulate the ship motion during the weighing procedure.

Fifty-two seabream juveniles ranging from 4 to 10 g were individually weighed using the dynamic scale. The following procedure was adopted: i) fish were first individually captured from the tank using a small fish net; ii) the fish was kept draining into the net for approximately 5 s; iii) after, drained fish was transferred into another net hanged to the lower hook of the scale, contextually the net was pulled and released to simulate the ship motion; iiiii) the measurement procedure has started, the dynamic scale was remote controlled using a Bluetooth terminal interface for Android smartphones[13]; iiiiii) recordings have been stored in files with the 'txt' extension.

Soon after each measurement, the same fish was also weighed using a Lab scale (Kern 440-47N; KERN & Sohn GmbH. Readability 0.1 g; Weighing range max. 2000 g). The weighing procedure was: i) weighing a small tank filled with seawater (tare); ii) smoothly placing each fish into the pre-tared tank (gross weight); iii) calculating the difference (net weight).

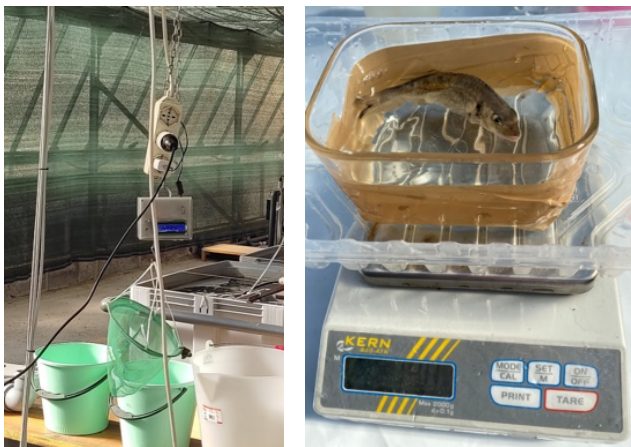

Figure 3. Weight measurements procedures. On the right side, the static scale with the pre-tared glass tank with water and fish; on the left side, the dynamic scale equipped with the tared net.

#### IV. RESULTS AND DISCUSSION

##### A. Tests results

In the Figure 4 the typical pattern of individual fish weighing by the dynamic scale is shown. Usually, after few seconds, a stable reading of fish weight is achieved, despite the shaking of the fish captured in the net and the given push to the net. The behavior of the readings over time, subsequent to the impulsive force, showed that a reasonable wait time of 2 second is enough to absorb the effect of the oscillation and return accurate readings. The last four fish weight readings appeared to be quite stable as shown in Figure 4 (right side). The recorded difference among each other was usually less than 1%. Moreover, in most cases, the CV among the different readings showed values ranging between 0.5 to 5 %. The higher CV within the 25 measurements performed during each reading-time, reached 15 %, in the worst case. The number of readings set as equal to 25 was proven to be enough reliable and accurate to measure the fish weight. Moreover, this readings setup is quick, avoiding much stress for the fish, in particular when compared to the static procedure. Indeed, the static

measurement is strongly affected by the swimming activity of the fish which sometimes causes leakage of water from the tared container, requiring to start again the weighing procedure.

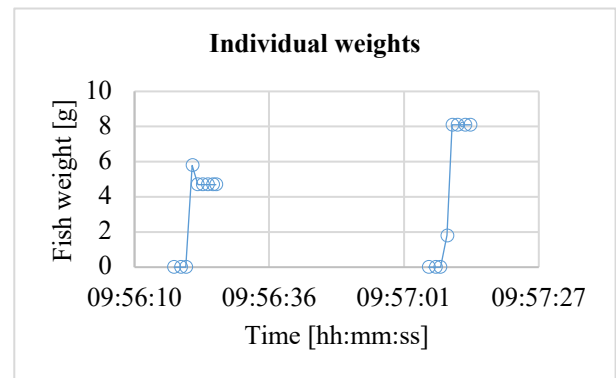

Figure 4. Recorded fish weight dynamic readings on a 8-second time-span.

Fish were then weighed by the 'static' scale in order to compare the two weighing procedures.

Figure 5, show the results of the comparison between dynamic and static scale on 52 individuals. The average of individual weight values and the standard deviation of the sample were  $7.2 \pm 1.31$ g, and  $7.1 \pm 1.28$  g for the dynamic and static measurements, respectively. The statistical comparison (Paired t-test, GraphPad Prism 9) between these values shows that the dynamic device is not significantly different to the static one ( $P < 0.001$ ).

Dynamic vs. static scale boxplot

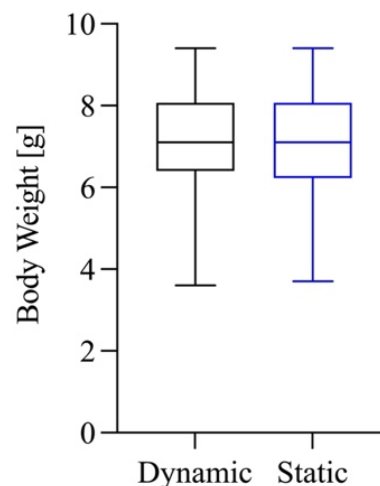

Figure 5. Boxplots (min. to max.) of the dynamic scale vs. static scale readings.

Figure 6 shows the results of the comparison test. The differences between dynamic and static scale readings were plotted vs. individual fish weight.

In all the tests with oscillating load (i.e., shaking fish and push) the differences between dynamic and static recorded values ranged between 0.5 and -0.4 g. The average relative

error was less than 1.4% with a maximum relative error of 5.8%. Anyhow it is not clear if the static procedure is accurate enough. The above-mentioned shaking and swimming of the fish in the small tank filled with water sometimes caused some drops to spill out the tank itself that could cause a wrong reading. An improvement of the static weighing procedure could be the use of anesthetic to sedate the fish before the measure.

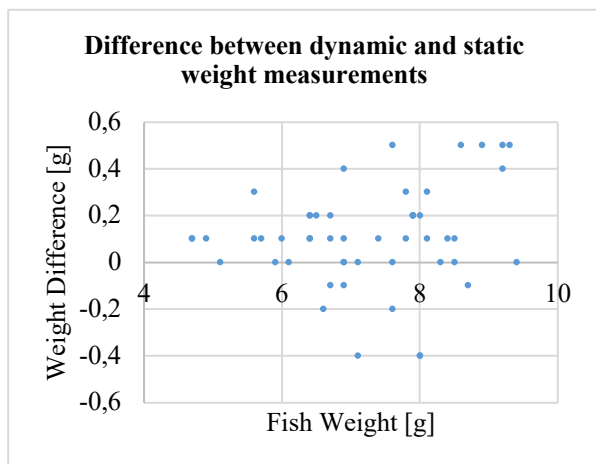

Figure 6. Recorded difference between dynamic scale vs. static scale readings.

The tendency of the dynamic measurements to be “above” the reference value can be attributed to the crude hooks employed to attach the fish net to the device, and not to an electronics issue. The “push” and “pull” effects on the hooks are not symmetric in our prototype, resulting in an asymmetric reading during oscillation. This minor issue could be easily solved in the mechanical design phase of the final device.

```

11:12:56.210 Ave_set: 10
11:12:57.064 0 g
11:12:58.003 TARE
11:12:58.958 0 g
11:12:59.927 0 g
11:13:00.856 1236 g
11:13:01.831 2132 g
11:13:02.753 2036 g
11:13:03.738 2036 g
11:13:04.668 2036 g
11:13:05.626 2036 g
11:13:06.576 2036 g
11:13:07.332 m
11:13:07.517 2036 g
11:13:07.620 Ave_set: 25
11:13:09.912 2036 g
11:13:12.336 2036 g
11:13:14.625 2036 g
11:13:15.299 s
11:13:17.024 2035 g
11:13:17.130 Ave_set: 100
11:13:26.702 2035 g
11:13:32.017 t
11:13:36.024 2034 g
11:13:45.701 2033 g
11:13:46.450 TARE
11:13:56.202 0 g

```

Figure 7. A preliminary test of Bluetooth communication between the device and a generic smartphone app. The light blue commands are sent from the smartphone to the device, while the green lines are the readings from the device. The timestamp is also shown. In this

test the calibrated scale was loaded with a load weighting  $2033 \pm 5$  g, in static conditions.

### B. Communication

The Bluetooth communication was implemented by a commercially available HC-06 BT module, fully compatible with Arduino-like boards and easily programmable to transmit and receive strings of data. The communication was tested with an Android smartphone: it worth noticing that no additional drivers are required. The communication between the device and a generic smartphone was tested using a Bluetooth serial monitor app [13]. Figure 7 shows a crude example of communication, in which a smartphone receives readings from the scale and can be used to tare the system and set the number of averages.

### C. Future developments

Further development of this device is required to be mass produced and marketed, but the results reported are very encouraging. The extreme versatility and flexibility of the operations, that could be achieved both at a hardware level (multitude of ready-to-assemble components commercially available) and at a software level (programmability of the microcontroller unit and of the smartphone/tablet app) are the main advantages.

Future developments and improvements may concern the design of the scale, in particular in the hook connected to the sensitive element, in order to avoid the “push” and “pull” effect on it. Furthermore, the same technology can be used to make a scale with a larger full-scale, which can be used to directly measure the biomass of an entire tank or cage.

## V. CONCLUSIONS

In a previous phase of the project, we have developed a scale capable of accurate measurements of oscillating loads. Applying a simple operative procedure capturing live fish in a small net, the same results were achieved. This opportunity is extremely relevant to efficiently monitor the fish growth of fish hosted either in-land facility or offshore pens. Measurement comparison performed by the dynamic and static scales showed almost similar average and standard deviation values. On the contrary, the static scale cannot operate on oscillating or shaking board. The dynamic scale proved to be suitable for live fish weighing goals.

In conclusion, the results obtained in this preliminary trial, suggests how the use of this kind of scale can successfully and accurately measure the fish biomass in moving conditions, in comparison with a traditional static device. However, in order to achieve a full exploitation of this device at commercial scale, a tool with a larger full-scale (i.e. 20 kg) is needed. Moreover, another improvement could be the use of an on-board automatic fish counter. The combination of these tools could be extremely useful for aquafarmers to monitor the fish biomass as quick as possible reducing stress and damage risk for fish. Moreover, due to the large diffusion of smartphones, this device also provides many advantages and application opportunities with respect to more classical instruments. Thus, we are quite confident that the present

device could fulfill the requirements of the fish farming sector.

## VI. REFERENCES

- [1] FAO, “The State of World Fisheries and Aquaculture 2020. Sustainability in action.,” FAO, Rome, Jun. 2020. doi: 10.4060/ca9229en.
- [2] C. Dupont, P. Cousin, and S. Dupont, “IoT for Aquaculture 4.0 Smart and easy-to-deploy real-time water monitoring with IoT,” 2018. [Online]. Available: <http://ec.europa.eu/research/participants/portal/>
- [3] D. Li and C. Li, “Intelligent aquaculture,” *Journal of the World Aquaculture Society*, vol. 51, no. 4. Blackwell Publishing Inc., pp. 808–814, Aug. 01, 2020. doi: 10.1111/jwas.12736.
- [4] A. Barbaresi, M. Agrusti, M. Ceccarelli, M. Bovo, P. Tassinari, and D. Torreggiani, “A method for the validation of measurements collected by different monitoring systems applied to aquaculture processing plants,” *Biosystems Engineering*, 2021, doi: 10.1016/j.biosystemseng.2021.07.011.
- [5] M. Føre *et al.*, “Modelling growth performance and feeding behaviour of Atlantic salmon (*Salmo salar* L.) in commercial-size aquaculture net pens: Model details and validation through full-scale experiments,” *Aquaculture*, vol. 464, pp. 268–278, Nov. 2016, doi: 10.1016/j.aquaculture.2016.06.045.
- [6] D. Li, Y. Hao, and Y. Duan, “Nonintrusive methods for biomass estimation in aquaculture with emphasis on fish: a review,” *Reviews in Aquaculture*, vol. 12, no. 3. Wiley-Blackwell, pp. 1390–1411, Aug. 01, 2020. doi: 10.1111/raq.12388.
- [7] F. Cardia and A. Lovatelli, “Aquaculture operations in floating HDPE cages: a field handbook.,” Rome, 2015.
- [8] M. Føre *et al.*, “Precision fish farming: A new framework to improve production in aquaculture,” *Biosystems Engineering*, vol. 173, pp. 176–193, 2018, doi: 10.1016/j.biosystemseng.2017.10.014.
- [9] “Arduino.” <https://www.arduino.cc/>. (accessed Aug. 10, 2021).
- [10] “I2C BUS.” <https://www.arduino.cc/>. (accessed Aug. 10, 2021).
- [11] “Aviaic semiconductor.” <http://en.aviaic.com> (accessed Aug. 10, 2021).
- [12] “Atmel microcontroller.” <https://www.microchip.com> (accessed Aug. 10, 2021).
- [13] E. Damiano, C. Bibbiani, B. Fronte, and A. di Lieto, “Smart and cheap scale for estimating live-fish biomass in offshore aquaculture,” in *IEEE International Workshop on Metrology for Agriculture and Forestry (MetroAgriFor)*, 2020, pp. 160–164. doi: 10.1109/MetroAgriFor50201.2020.9277662.
- [14] “Serial Bluetooth Terminal.” <http://www.kai-morich.de/android/> (accessed Aug. 10, 2021).