



**2<sup>nd</sup> Global Virtual Summit on Catalysis & Chemical Engineering**

**March 14-16, 2022**



# **Progress on the removal of contaminants on surface and wastewater: report of case-studies**

***Laura Scrano, Sabino Aurelio Bufo and Lee-Ann Modley***

***The University of Basilicata, Potenza, Italy.***

***The University of Johannesburg, Department of Geography, Environmental Management & Energy Studies, Johannesburg, South Africa.***





## 2<sup>nd</sup> Global Virtual Summit on Catalysis & Chemical Engineering March 14-16, 2022

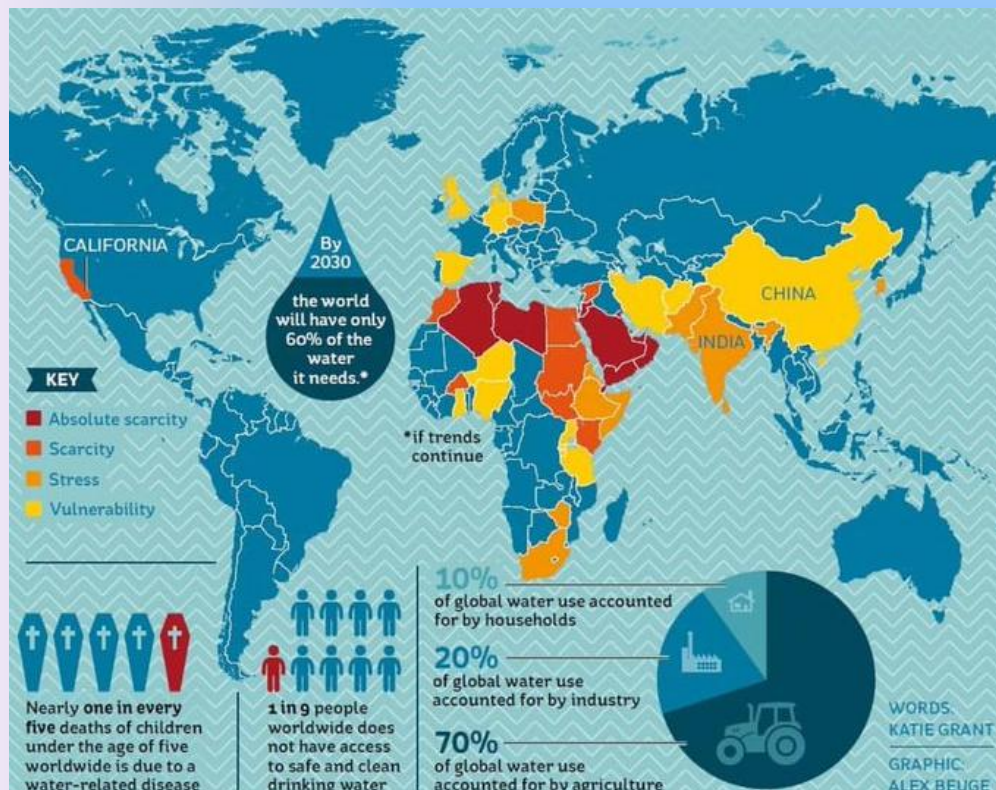

**Water scarcity is one of the biggest problems facing the world at every level: social, economic, political and environmental. It is becoming acute as climate change exasperates efforts to provide water to a growing population. It is estimated that about 70% of water is used in the agricultural sector, 20% in the industrial sector and 10% in the domestic one.**





**2<sup>nd</sup> Global Virtual Summit on Catalysis & Chemical Engineering**  
**March 14-16, 2022**



**Due to the increasing water demand, it is necessary to adopt alternative water supplies. A good idea could be to reuse wastewater after its decontamination.**

**GROWING WATER  
SCARCITY**



**NECESSITY FOR  
ALTERNATIVE WATER  
SUPPLIES**



## POLLUTION PROBLEMS

*The contamination of soils, groundwater, and surface water by hydrophobic organic compounds is currently a significant concern throughout the world because many of these compounds are detrimental to human health and the environment.*

*The cleaning up of contaminated water is one of the most challenging and expensive goals in environmental Engineering.*





*2<sup>nd</sup> Global Virtual Summit on Catalysis & Chemical Engineering*  
*March 14-16, 2022*



The domestic and industrial use of water generates a high quantity of sewage and residual wastewater after sewage treatments, which direct disposal into natural channels is of considerable impact for the environment. Together with the need to recuperate water for new uses, this fact makes practically essential the purification of wastewater to achieve the desired degree of quality.





## Wastewater reuse

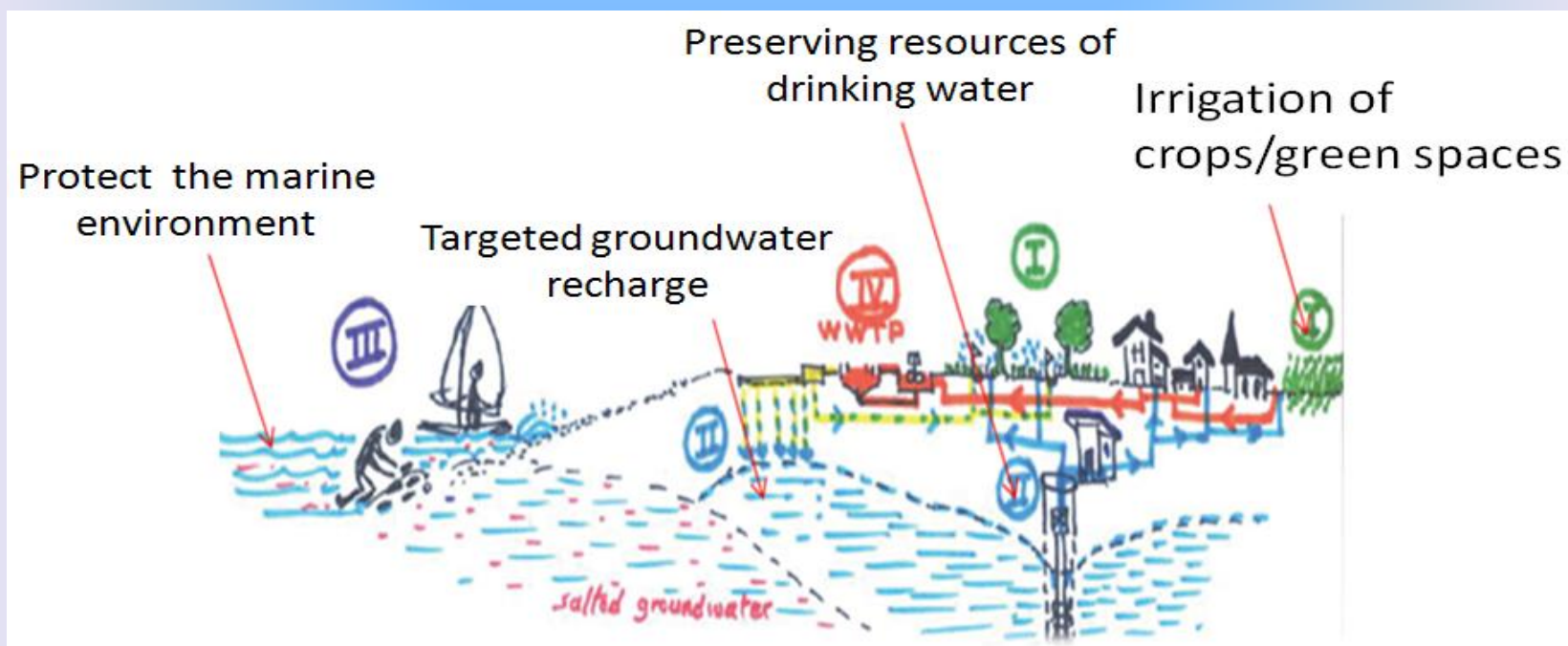

Sewage is generated by residential, institutional, commercial and industrial establishments. It includes household waste, liquid from toilets, baths, showers, kitchens, sinks and so forth disposed of via **sewers**. In many areas, sewage also includes liquid waste from industry and commerce.



## What's in your wastewater?



## ORGANIC POLLUTANTS

- Pesticides and Herbicides



- Materials for common household use



- Pharmaceuticals



- Materials for industrial use





## Other contaminants



*Escherichia coli* (a), *Giardia muris* (b), *Campylobacter coli* (c), *Salmonella* spp (d)



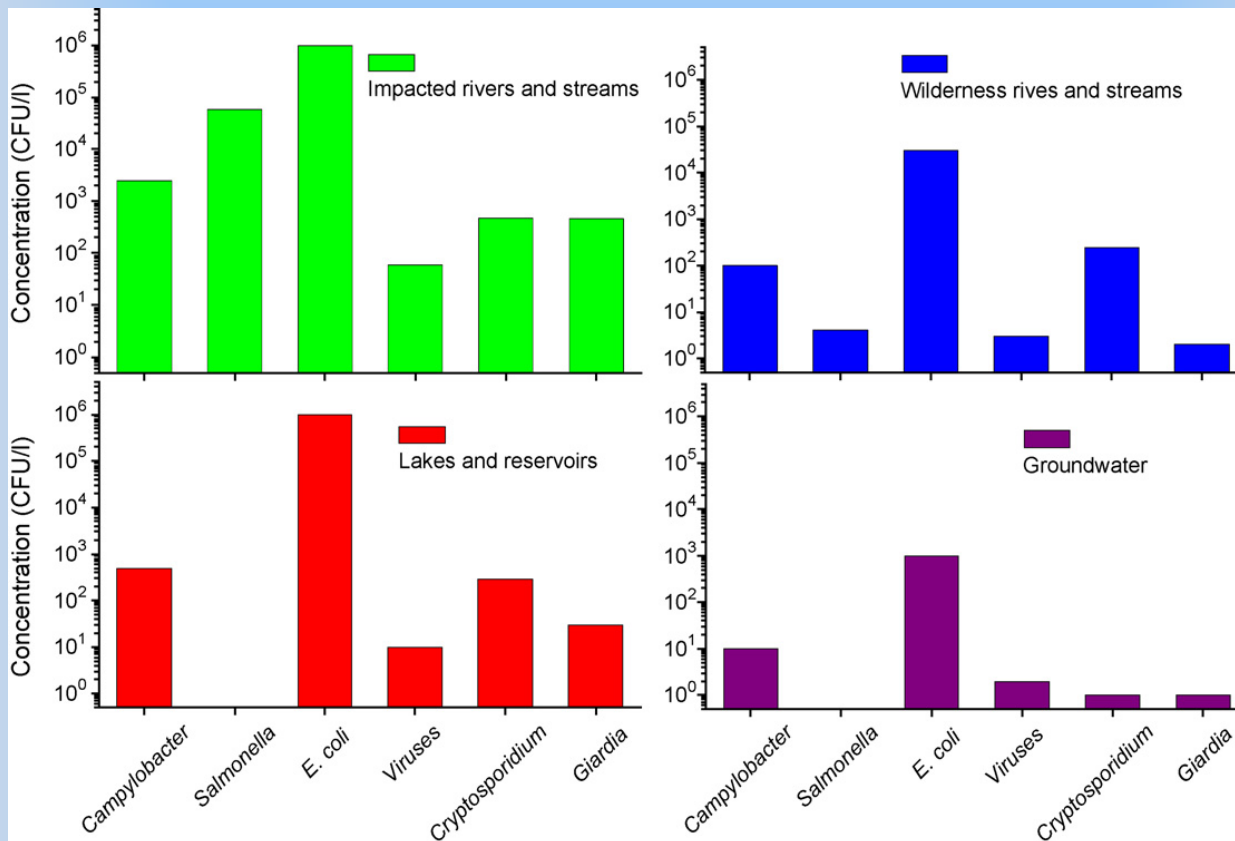

Concentrations (in CFU per liter) of enteric pathogens and fecal indicators in different types of water sources





## Further pollution: Emerging contaminants (E.C.)

### Environment Protection Agency (EPA) List :

**Trichloropropane (TCP)** – The result of hazardous waste disposal

**Dioxane** – cosmetics, detergents, and other household products

**Trinitrotoluene (TNT)** – Explosive used for military purposes,

**Dinitrotoluene (DNT)** – Used in the manufacturing of flexible polyurethane foams, which can be found in bedding, furniture, automotive interiors, carpet underlay and packaging

**Nanomaterials** – Used to manufacture eyeglasses, crack-resistant paints, coatings for walls, transparent sunscreens, stain-repellent fabrics, windows, and ceramic coatings for solar cells

**N-Nitroso-dimethylamine (NDMA)** – Can be found in tobacco products, cosmetics, detergents, cured meats, and rocket fuel

**Perchlorate** – Used to make fireworks, explosives, airbag initiators for vehicles, matches, signal flares, fertilizers, and chlorine.

**Perfluorooctane sulfonate (PFOS)** – Used in cleaning products, firefighting foams, metal plating, aviation fuels, and the semiconductor industry

**Perfluorooctanoic acid (PFOA)** – Used in stain-resistant carpets and fabrics, and nonstick cookware

**Polybrominated biphenyls (PBBs)** – Added to plastics used in home electrical appliances, textiles, plastic foams, laptop cabinets, making them more fire-resistant... and other





## Drinking water decontamination/disinfection needs

*WORD HEALT ORGANIZATION recognized the disinfection as one of the most important barriers for protection of public health*

## Irrigation water decontamination-disinfection needs

*Agriculture consumes 70% of fresh water and a sharp increase in irrigation  
The use of safe water is essential for all living organisms.*



## Traditional Sewage treatment

**Pre-treatment** removes all materials that can be easily collected from the raw sewage. The solids are collected and later disposed of in a landfill or incinerated.

**Primary treatment** temporarily holds the sewage in a quiescent basin where heavy solids can settle to the bottom while oil, grease, and lighter solids float to the surface. The settled and floating materials are removed, and the remaining liquid may be discharged or subjected to secondary treatment.

**The secondary treatment removes dissolved and suspended biological matter in a managed habitat by indigenous, water-borne micro-organisms.**



The objective of sewage treatment is to produce a disposable effluent without causing harm to the surrounding environment, and prevent pollution.



Simplified process flow diagram for a typical large-scale treatment plant







## Tertiary treatment

If it is sufficiently clean, treated water can be discharged into a stream, river, bay, lagoon or wetland and used for groundwater recharge or agricultural purposes.

***Otherwise, a Tertiary treatment is essential.***

- **Chlorination;** *disinfection byproducts (trihalomethanes) + NH<sub>3</sub> = chloramine*
- **Ozonation;** *ozone cannot persist, and water can be contaminated again*
- **Activated carbon adsorption;** *high cost*
- **Micro-filtration (MF);** *microorganisms are not completely removed*
- **UV disinfection;** *this method alone (and chlorination alone) will not remove toxins from bacteria, pesticides, heavy metals, etc.*





## **Advanced Tertiary Treatments**

The European Directive 2013/39 stresses the need to adopt more robust measures against water pollution, especially endocrine disrupting compounds (EDCs), recalcitrant pesticides, pharmaceuticals and personal care products, known as **emerging micropollutants**.

Many of these compounds are not removed or destroyed in the WWTPs to be found in the effluent water in concentrations ranging from nano- to micro-grams/L, either as mother molecules or derivative/transformation by-products.





*2<sup>nd</sup> Global Virtual Summit on Catalysis & Chemical Engineering*  
*March 14-16, 2022*



Time ago, more attention has been given to pollutants that are present in the environment at lower concentrations but nevertheless represent an environmental threat, such as pharmaceutically active compounds (PhACs) and their metabolites

PhACs and their metabolites are considered risky substances to humans and animals due to their accumulation in drinking water through a number of pathways, primarily from sewage treatment effluents and sludge

Some of these chemicals were found in similar levels quantity as pesticides, up to micrograms per liter range, in rivers, streams, lakes, and even in ground water used for human consumption





*2<sup>nd</sup> Global Virtual Summit on Catalysis & Chemical Engineering*  
*March 14-16, 2022*



Many attempts have been made to integrate or ameliorate the tertiary process in the WWTP to reduce the concentration of emerging pollutants in the effluent. Still, the effectiveness of new tools mostly depends on the composition and quality of wastewater.

**New methods: Advanced oxidation processes (AOPs)**

New treatment procedures have been designed to remove most organic contaminants, including microorganisms, in water and wastewater by oxidation through hydroxyl radicals ( $\cdot\text{OH}$ ) reactions.





*2<sup>nd</sup> Global Virtual Summit on Catalysis & Chemical Engineering*  
*March 14-16, 2022*



**AOPs** employ:

- Ozone ( $O_3$ ), and hydrogen peroxide ( $H_2O_2$ ) with or without UV light irradiation
- $TiO_2$ /UV photocatalysis, Fenton, photo-Fenton, electro-Fenton, and Oxone Fenton-like reactions (Generation of sulfate radicals from peroxydisulfate, as primary oxidising via electron transfer by transition metal ( $Fe^{2+}$ )).

The contaminant materials are converted to a large extent into stable inorganic compounds such as water, carbon dioxide and salts, i.e. they undergo mineralisation.

Recent trends include developing new, modified AOPs that are efficient and low cost. There have been some studies that offer constructive solutions. For instance, doping  $TiO_2$  with metallic and non-metallic elements could enhance photocatalytic activity; and ultrasonic treatment could promote the production of hydroxyl radicals.





## AOPs are very useful for water disinfection

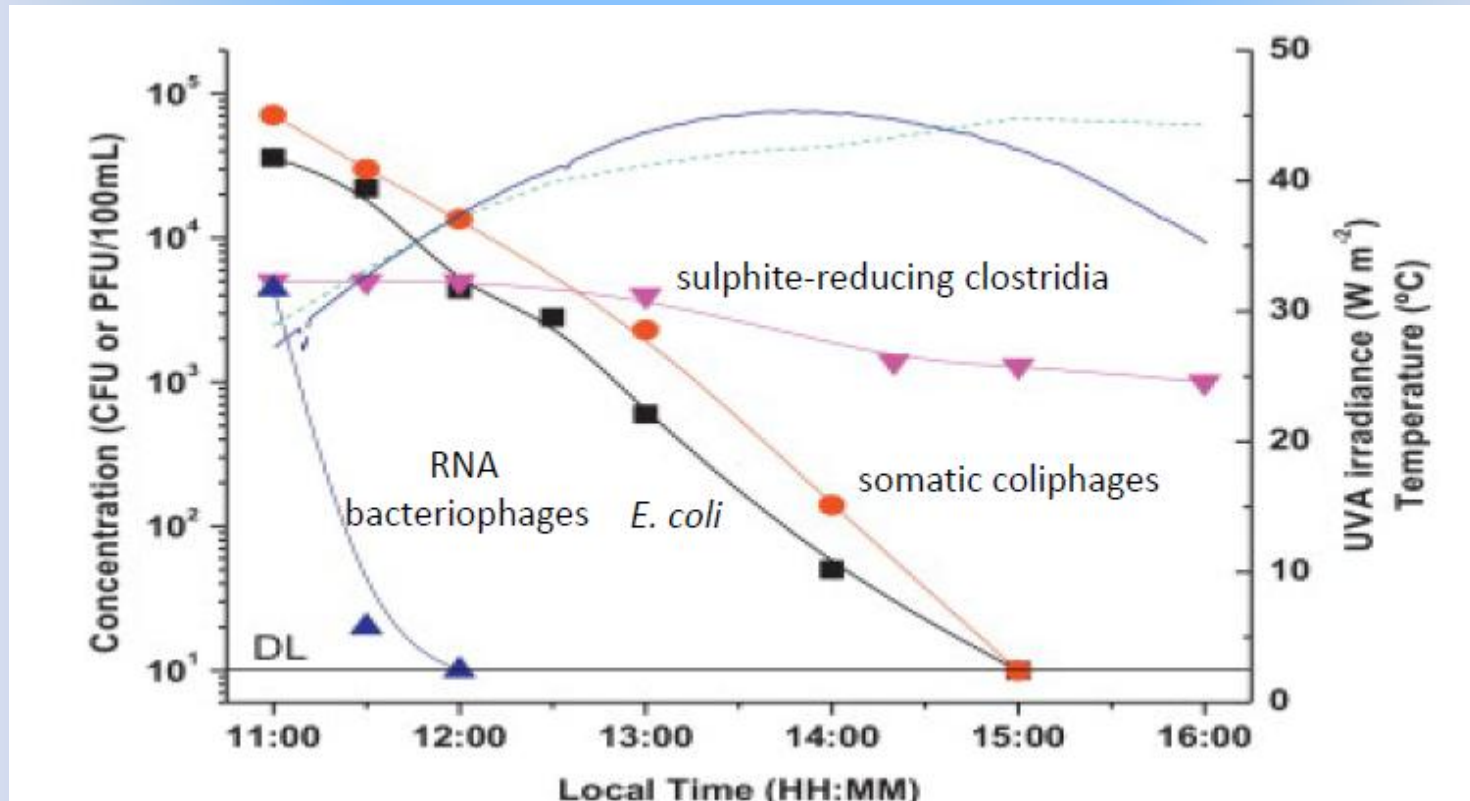

Inactivation of all the microbial indicators tested in a single representative experiment of TiO<sub>2</sub> (100 mg L<sup>-1</sup>)/solar UVA.



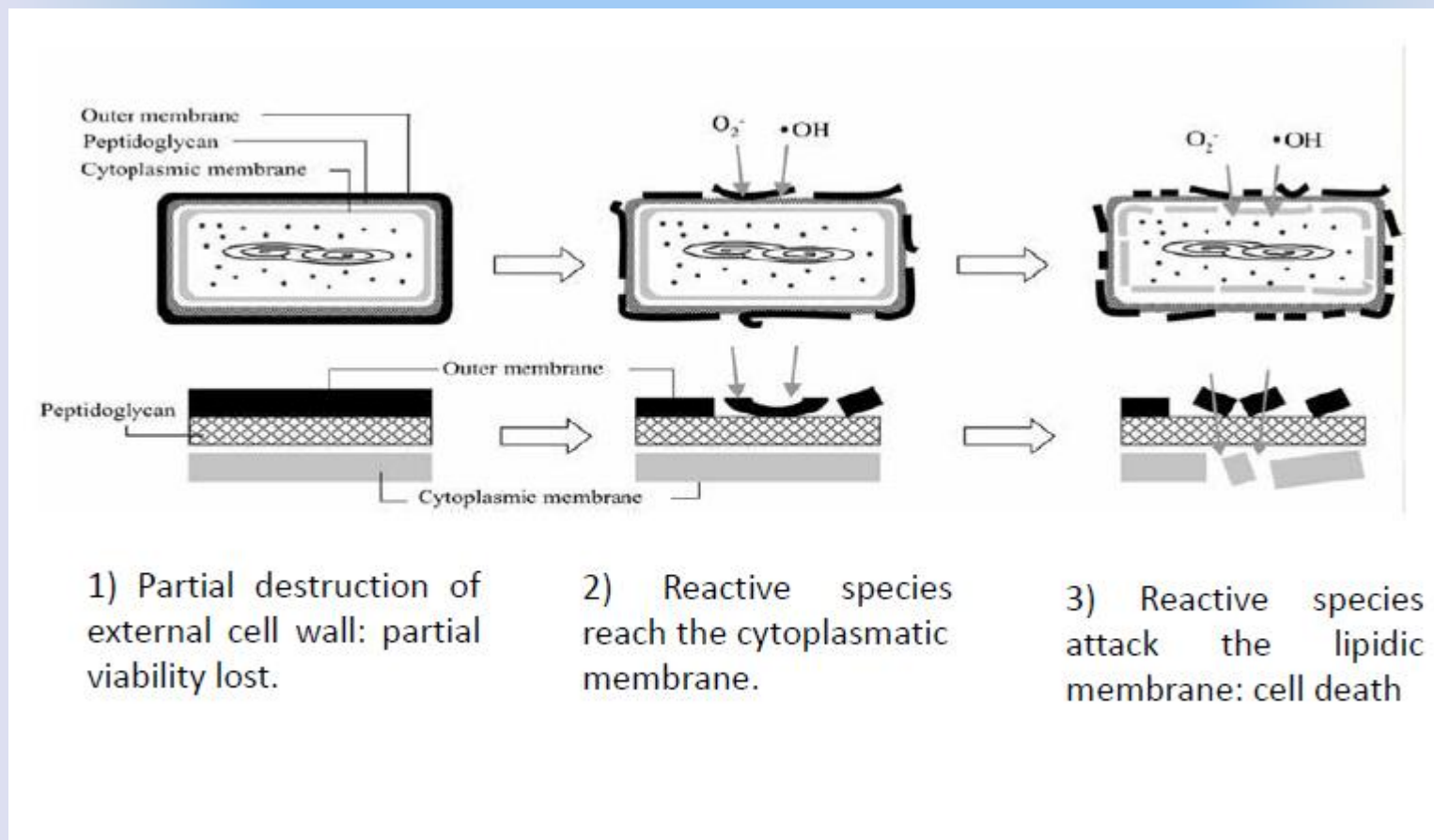

Scheme of photo-destruction ( $\text{TiO}_2$ ) process



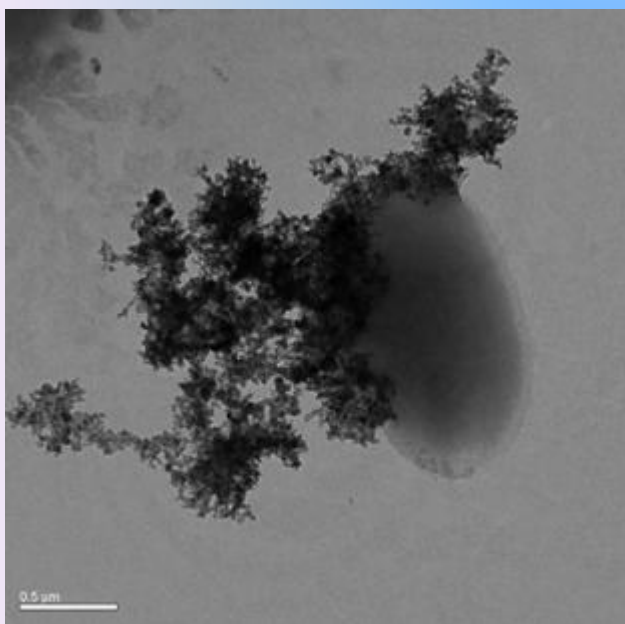

**Photocatalytic inactivation** caused by  $\text{TiO}_2$  in contact with *E. coli*

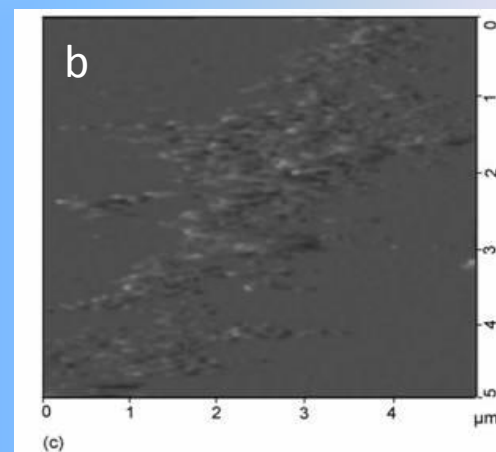
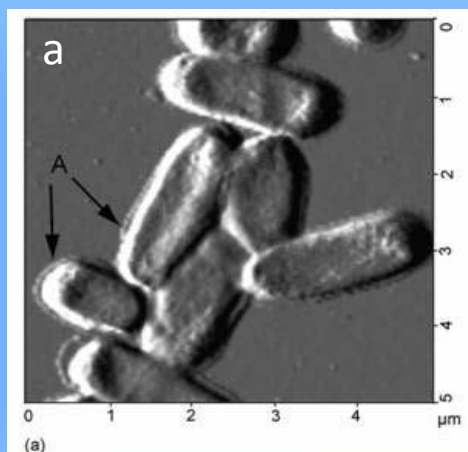

AFM image of *E. coli* cells on a  $\text{TiO}_2$  film : (a) no irradiation, (b) after six days of irradiation is observed a complete cell decomposition



## First case study – Removal of Diazepam from Wastewater using different treatment technology \*

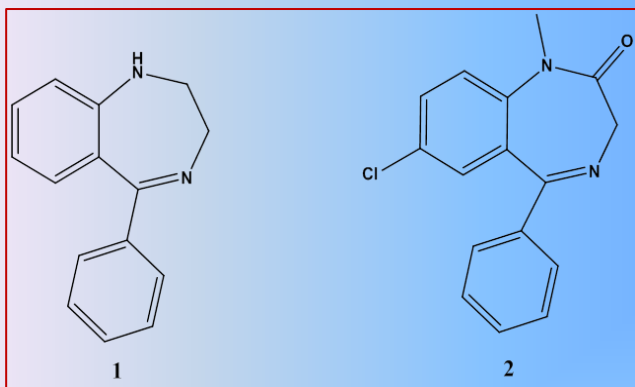

Chemical structures of Benzodiazepine (1) and diazepam (2)

Benzodiazepines have received recent consideration. A most known member of the benzodiazepines is Diazepam used to relieve anxiety, muscle spasms, and seizures and control agitation in both adults and children. In fact it is anticonvulsant, anxiolytic, sedative and muscle relaxant.

\* Saleh Sulaiman, Mustafa Khamis, Shlomo Nir, Filomena Lelario, Laura Scrano, Sabino A. Bufo and Rafik Karaman (2015) Removal of organic pollutants from wastewater using different treatment technologies. *Case Studies Journal* ISSN (2305-509X) – Volume 4, Issue 5



*2<sup>nd</sup> Global Virtual Summit on Catalysis & Chemical Engineering*  
*March 14-16, 2022*



Benzodiazepines, as a lot of pharmaceuticals, are not completely metabolised in the body. Consequently, significant amounts of various human degradation products into the aquatic environment are released. These substances can be further transformed during sewage treatment hurting the aquatic ecosystem.

Indeed, the degradation by-products cause, sometimes, a significant concern because they may have toxicity similar to or higher than the parent compounds. Building on those findings, the toxicity effects on water microfauna, and considering that previous studies have demonstrated the inefficiency of the conventional water and wastewater treatment processes, the need to eliminate those residual compounds from a different kind of water appeared evident.





Two experiments were carried out: biological degradation by using Advanced Wastewater Treatment Plant (WWTP) located in Al Quds University and Advanced Oxidation Processes (AOPs) at the University of Basilicata

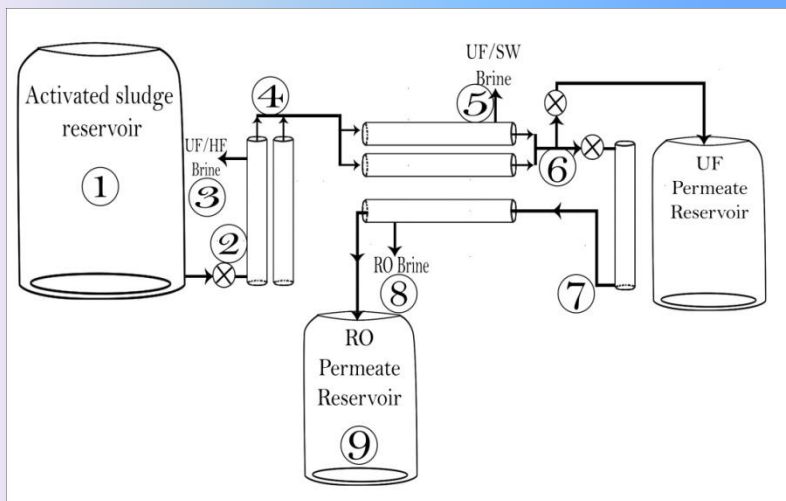

**WWTP schema at Al-Quds University**

*UF / HF, hollow fibre ultrafiltration membrane; UF/SW, spiral wound ultrafiltration membrane; RO, reverse osmosis; GAC, granular activated charcoal filter*



*Solar Pilot for Advanced Oxidation Processes (project NANOWAT) at University of Basilicata*





*2<sup>nd</sup> Global Virtual Summit on Catalysis & Chemical Engineering*  
*March 14-16, 2022*



The efficiency of WWTP has shown exciting results about the removal of this drug but to reach a further purification of water; it is necessary the use reverse osmosis.

Nevertheless, the advanced technology adopted in the WWTP of Al-Quds University did not overcome a problem common to all plants: brine production. A large portion of the contaminants ends up being concentrated there. As reverse osmosis is very expensive, the AOPs process was proposed and applied.  $\text{TiO}_2$ , used as a catalyst, owns two essential properties: high photocatalytic activity and low cost.





**2<sup>nd</sup> Global Virtual Summit on Catalysis & Chemical Engineering**  
**March 14-16, 2022**

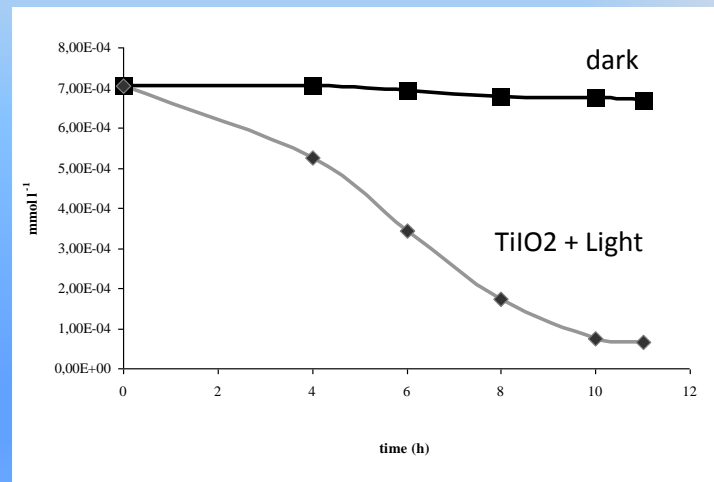
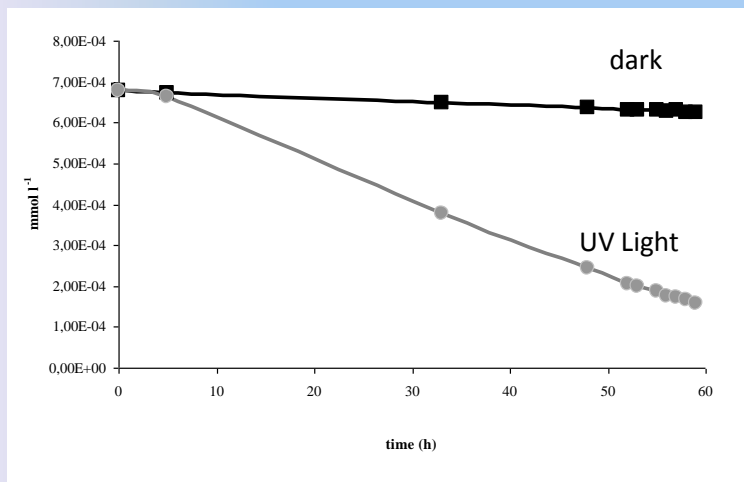

Photo-degradation of diazepam was much faster under light irradiation +TiO<sub>2</sub> ( half-life = 6 hours) than under Suntest irradiation (half-life = 34 hours).

Considering that the photocatalytic process starts after the biological treatment on the water body containing a minimal quantity of contaminants, the removal of this pharmaceutical compound was quite complete, and the degradation products were detected below the legal limit.

**Kinetic parameters of Diazepam degradation: n, reaction order; t<sub>1/2</sub>, half-life; k, kinetic constant; R<sup>2</sup>, determination coefficient. Values were obtained based on three replicate experiments.**

Oxidation Process	n	t <sub>1/2</sub> (h)	k(h <sup>-1</sup> )	R <sup>2</sup>
UV	1	34.14	0.0203	0.99
TiO <sub>2</sub> /UV	1	5,33	0.132	0.97



TiO<sub>2</sub> Sunlight's process shows a better mineralization capacity at low diazepam concentrations within these experimental conditions.



In water diazepam was found to be susceptible to photo-degradation under conditions simulating natural sunlight using a filtered Xenon Light Source

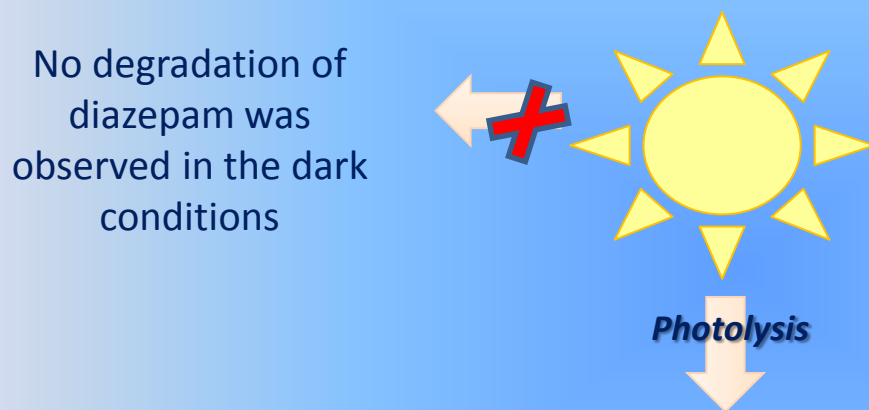

	Chemical formula	RT (min.)	m/z	error (mg L <sup>-1</sup> )
Diazepam	$C_{16}H_{14}ON_2Cl$	7.88	285.07910	0.64
	$C_{17}H_{16}O_2N_2Cl$	1.71	315.08948	0.46
	$C_{14}H_{10}NOCl$	16.37	244.05237	-0.0009



Summary of diazepam photoproducts' structures under photolysis and photocatalysis processes

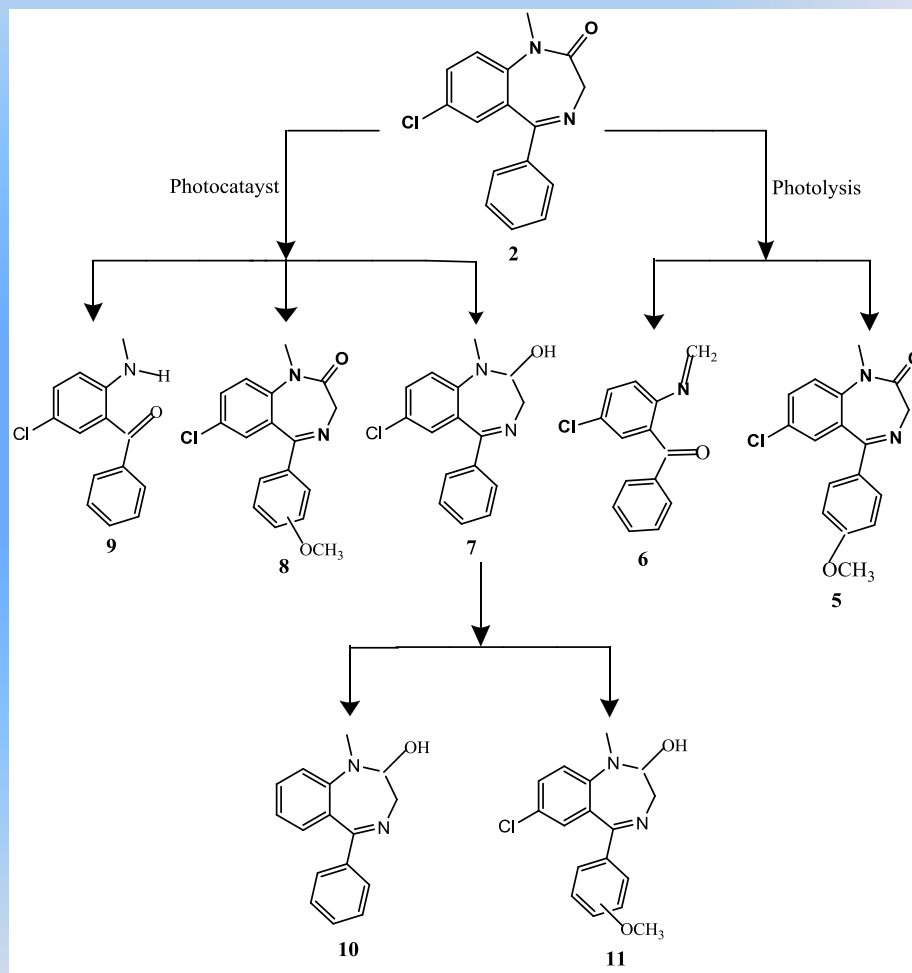





*2<sup>nd</sup> Global Virtual Summit on Catalysis & Chemical Engineering*  
*March 14-16, 2022*



The efficiency of WWTP has shown exciting results about the removal of this drug, but to reach a further purification of water the AOPs process was proposed and applied.

The experimentation showed the efficiency of this integrated system that permitted, also, the removal of all degradation products.



## Second Case Study – Fluoroquinolones In Water: Removal Attempts By Innovative AOPS \*

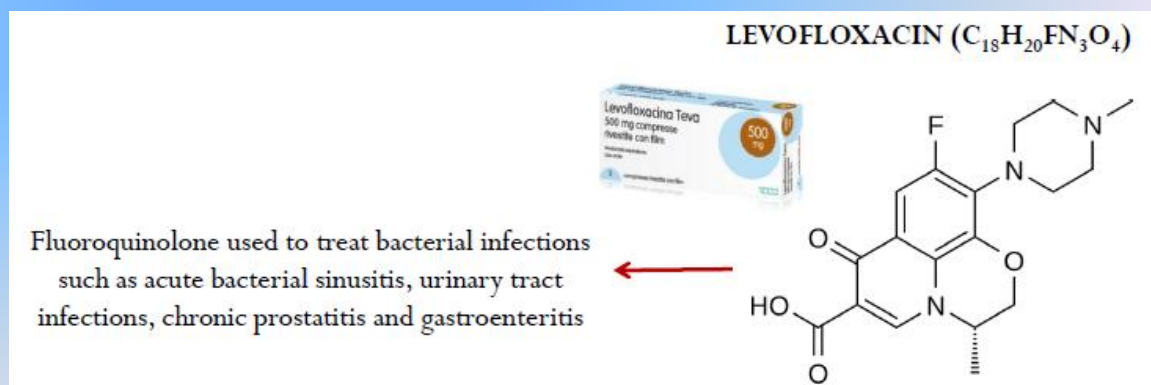
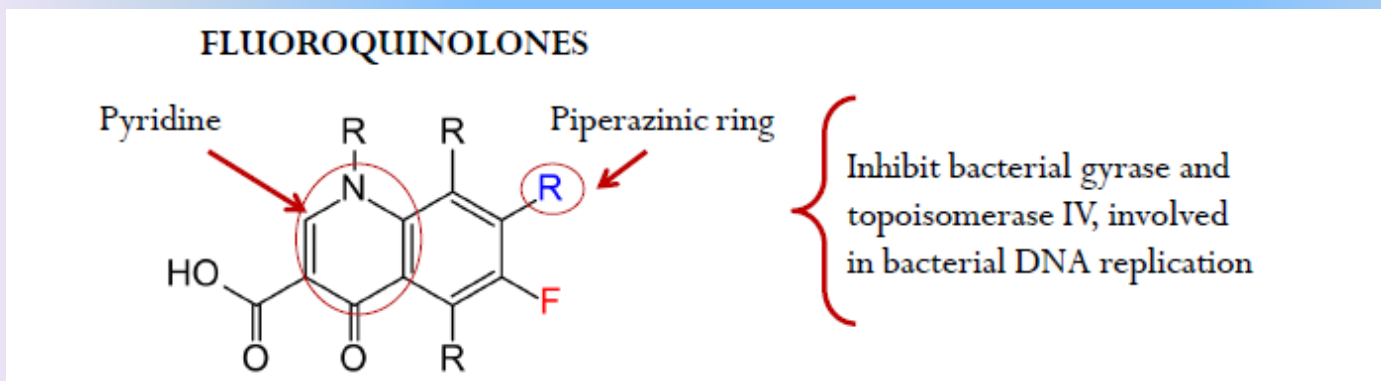

\* Scrano L., Foti L., Lelario F. (2020) Fluoroquinolones in water: removal attempts by innovative AOPS. NATO Science for Peace and Security Series, A: Chemistry and Biology, 259-263.

## Photolysis and heterogeneous photocatalysis with TiO<sub>2</sub> powder



**IRRADIATION APPARATUS:** Heraeus Suntest CPS Instrument equipped with Xenon Arc lamp (1.8 KW). Irradiations were performed with a light power of 400 W/m<sup>2</sup>, with a spectral wavelength ranging between 290 and 800 nm.

- 1) Direct photolysis  $\rightarrow$  1<sup>st</sup> degradation test  
C<sub>LFX</sub> (10 mg/L)
- 2) Photocatalysis  $\rightarrow$  2<sup>nd</sup> degradation test  
C<sub>TiO<sub>2</sub></sub> (200 mg/L)  
C<sub>LFX</sub> (10 mg/L)



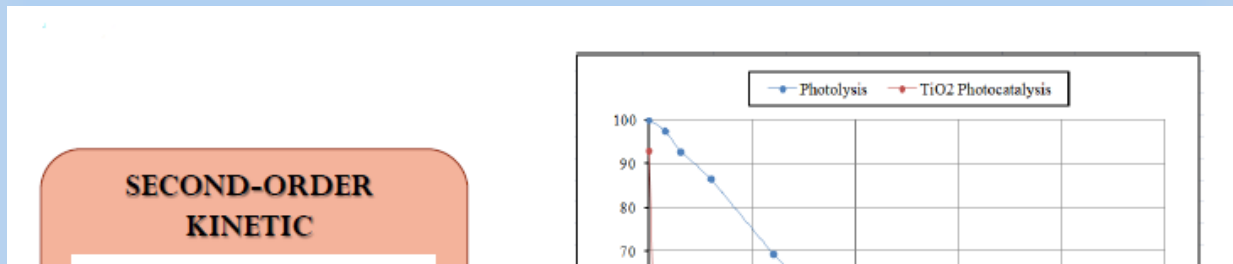

- Heterogeneous photocatalysis by using TiO<sub>2</sub>-powder removes LFX and its by-products in four hours
- The degradation seems to follow a second-order kinetic
- The main disadvantage is represented from the necessity of a post-treatment stage to recover the catalyst

	Second-order	$C_0/C_1 = 1 + (1/t_{1/2})t$	27.8388	0.8632	80.61	0.0012 L·mg <sup>-1</sup> ·min <sup>-1</sup>
TiO <sub>2</sub> powder	Zero-order	$C_1 = C_0 - kt$	28.1803	0.5649	50.37	0.0566 mg·L <sup>-1</sup> ·min <sup>-1</sup>
	First-order	$\ln C_1 = \ln C_0 - kt$	56.0970	0.9182	32.97	0.0210 min <sup>-1</sup>
	Second-order	$C_0/C_1 = 1 + (1/t_{1/2})t$	1.9206	0.9696	8.19	0.0123 L·mg <sup>-1</sup> ·min <sup>-1</sup>



## Photocatalysis with supported TiO<sub>2</sub> and toxicity assessment



**IRRADIATION APPARATUS:** Heraeus Suntest CPS Instrument equipped with Xenon Arc lamp (1.8 KW). Irradiations were performed with a light power of 400 W/m<sup>2</sup>, with a spectral wavelength ranging between 290 and 800 nm.

- 1) Photolysis (without TiO<sub>2</sub>-coated tube) → 1<sup>st</sup> degradation test  
C<sub>LFX</sub> (20 mg/L)
- 2) Photocatalysis (with TiO<sub>2</sub>-coated tube) → 2<sup>nd</sup> degradation test  
C<sub>LFX</sub> (20 mg/L)



**FIRST-ORDER  
KINETIC**

$$\ln(C_t) = \ln(C_0) - k \cdot t$$

$$t_{1/2} = (\ln 2) / k$$

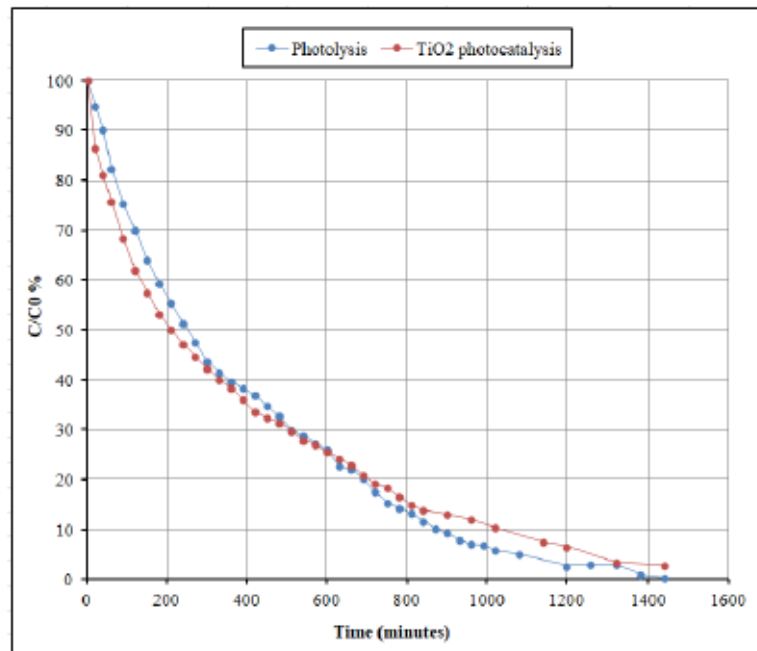

System	Reaction Order	Linearised Rate Equation	$(C_{exp}-C_{calc})^2$	R <sup>2</sup>	t <sub>1/2</sub> (min)	k
Photolysis	Zero-order	$C_t = C_0 - kt$	202.10	0.8499	785.40	0.0131 mg L <sup>-1</sup> ·min <sup>-1</sup>
	First-order	$\ln C_t = \ln C_0 - kt$	50.01	0.9417	227.78	0.0030 min <sup>-1</sup>
	Second-order	$C_0 C_t = 1 + (1/t_{1/2})t$	1750.88	0.2359	16.55	0.00294 L·mg <sup>-1</sup> ·min <sup>-1</sup>
TiO <sub>2</sub> -coated tube	Zero-order	$C_t = C_0 - kt$	179.56	0.8096	574.02	0.0129 mg L <sup>-1</sup> ·min <sup>-1</sup>
	First-order	$\ln C_t = \ln C_0 - kt$	90.824	0.9856	314.06	0.0022 min <sup>-1</sup>
	Second-order	$C_0 C_t = 1 + (1/t_{1/2})t$	573.327	0.5898	64.33	0.0007 L·mg <sup>-1</sup> ·min <sup>-1</sup>





*Vibrio fischeri*

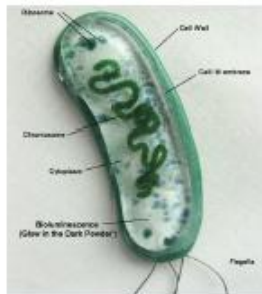

MicroTox system



Toxicity Test

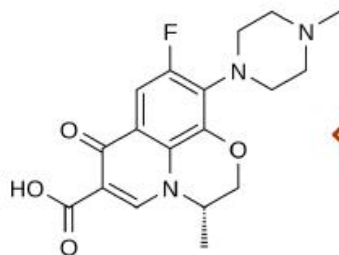

LEVOFLOXACIN



Seed germination



Radical elongation



Growth index





*2<sup>nd</sup> Global Virtual Summit on Catalysis & Chemical Engineering*  
*March 14-16, 2022*



This presentation aims to show how important is to create integrated systems for the removal of pollutants. Artisans, Farmers, Small businesses, Family-run businesses and others can purify their own waters, reuse them and/or insert them, into the global circuit, already cleaned up.





Pilot equipment designed for filtration of water containing organic and inorganic contaminants using clay-composite materials (European project NANOWAT)







2<sup>nd</sup> Global Virtual Summit on Catalysis & Chemical Engineering  
March 14-16, 2022



Solar Pilot for Advanced Oxidation Processes (European project NANOWAT)





*Tiers of limestone create the stage  
where waters tumble, flow and dance,  
all below a canopy of green.*

*Yes, this is the water I would like*

*Thanks for your attention*

