

3D printed telescopes: an interesting tool for teaching Astronomy, Science and Technology

Roger Macías^{1}, Antonio Marzoa^{1,2}, Oriol Casamor^{1,2}, Joan Soler¹, Daniel Fernández³*

Abstract

3D printing technologies experienced a huge evolution both in techniques and applications since its invention in the early 1980s. Fused Deposition Modelling (FDM) was the first term used to describe an additive manufacturing technique and from that point on, many different ways of 3D printing have been developed to fulfil a variety of needs.

Nowadays, 3D printing has become more accessible to the general public because of the big drop in prices caused by the big technical developments. As a result of that, a community of “makers” has been taking shape internationally making access to designs and advice easier.

3D printing is without a doubt one of the key developments of the last decades and covers from highly technical research fields (like medicine-related investigations) to individual makers or even educational programs to encourage young people to create.

As a result of that, it can be seen daily that the so-called 3D printing has gained a big amount of fame between fabrication processes for its accessibility and ease of use, it only takes a computer, a 3D printer and time. On behalf of that, an idea for a final degree thesis was proposed: designing and printing using fused deposition modelling a telescope for astronomical and educational purposes.

The main goal of the project is to, first check the capabilities of the 3D printing technology to build telescopes for amateur astronomers, comparing its performance with the current commercial products, and secondly, to develop a set of educational resources that permit the easy construction of low-cost custom instruments for the teaching and diffusion of Astronomy and Space Science. The set of resources derived from this project will be an interesting tool for Astronomy beginners, Engineering and Science students, teachers, and makers.

In this work, we summarise the current status of the project and the results obtained with the first built prototype, as well as the design and choices made to fulfil our needs in a practical and feasible way. Last but not least, a list of possible educational activities to be carried out with the developed resources will be exposed.

Keywords

3D printer, Additive manufacturing, Astronomy, Education, Telescope

^{1*} Corresponding author: roger.macias@estudiantat.upc.edu

¹ Departament de Física, Universitat Politècnica de Catalunya, Spain

² SENER Aeroespacial, S.A., Spain

³ Agrupació Astronòmica de Sabadell, Spain

Acronyms/Abbreviations

CAD	<i>Computed Aided Design</i>
FDM	<i>Fused Deposition Modelling</i>
FFF	<i>Fused Filament Fabrication</i>
SLA	<i>Stereolithography</i>

1. Introduction

3D printing is a technology that has been around us for more than four decades [1].

The pioneering 3D printing works date from 1981 and were carried on by the Japanese automobile designer Hideo Kodama.

Kodama invented a new manufacturing technique that consisted of the addition of layers using resin polymerized under UV light irradiation. However, Kodama's invention did not fit the requirements for patent claiming, and he was not officially recognized as the inventor of the procedure.

In 1986, a group of French investigators failed to file a patent for a monomer curing system by means of a laser. That same year, a patent for SLA by Charles Hull, who was searching for a fabrication technique that let him build small parts for furniture in an easy way, was published. Hull's technique consisted of a system that cured resin by exposing it to UV light, layer by layer.

Later on, in 1988, Charles Hull founded the enterprise 3DSYSTEMS [2], a company dedicated to the development of 3D printers and related technology.

At that same time, the first iteration of the most famous 3D printing method was patented. Scott Grump submitted the patent for Fused Deposition Modelling (FDM) or Fused Filament Fabrication (FFF), which was a printing method that consisted of extruding material through a pre-heated nozzle in order to melt it.

During the 1990 decade, the industry benefited from the emerging different CAD software, increasing the ability of both individuals and companies to mass-produce designs that could be easily exportable to 3D printing formats that existed at that time.

Later on, in the first decade of the 2000s, two major milestones of 3D printing were achieved. The first of them, achieved in 2005 being the creation of the RepRap Project [3], which consisted in designing an OpenSource printer that could be mainly built using pieces

previously printed with another 3D printer, basically a "self-replicating manufacturing machine" (as told by RepRap themselves). This, in fact, opened the doors of amateur 3D printing by enabling the general public to print their own print farms.

The second major accomplishment of this technology was achieved in 2008 when the first fully printed prosthetic leg was unveiled giving 3D printing a big media coverage and helping it expand all over the world.

Since then, 3D printing has done nothing less than keep expanding through the globe and becoming key in technological developments in fields such as medicine, fabrication methods or even in the aerospace industry with the design and fabrication of new rockets with many of its components 3D printed.

As an example, a recent work [4] has shown the possibilities of the practical implementation of 3D print optomechanical hardware with high-performance rates and with a cost much lower than if conventional commercial hardware was bought. This reference is an illustrative example (among many others) on how 3D printing technologies can be a game-changer in research and development in many areas of the optical industry.

2. Contextualization of the project: Amateur Astronomy

Amateur Astronomy is a field in which different technical skills and needs converge. The amateur astronomical community is formed by thousands of motivated people that want to know more about the Cosmos and to transmit that knowledge. Furthermore, a huge fraction of that community is also interested in do-it-yourself projects

This section summarises the different designs of telescopes commonly used by the amateur community and the different approaches in which, as far as the authors know, several members of the community have been made with 3D printing technology.

2.1. Types of telescopes

Telescopes are basically divided into three types: refractors, reflectors and catadioptric.

In this subsection, the three main types of telescopes used by amateur astronomers are briefly introduced and described.

2.1.1. Refractors

This type of telescope is based on the use of refracting elements (lenses). The main design known as Keplerian telescope is compound by

two positive (i.e, converging) lenses (the objective and the eyepiece), and it is the principal design used nowadays (despite optical corrections such as the use of achromatic doublets or inversors for the case of terrestrial telescopes). Another common design is the Galilean telescope, which uses a negative (divergent) lens as eyepiece. An example of a Keplerian telescope is shown in Figure 1a).

Refractors need little to no maintenance because of their lenses being static and fixed to the tube. This kind of telescope provides superb colour contrast and are generally compact.

Even though its simplicity, refractors suffer from chromatic aberration, a phenomenon caused by the different focus points that light can have when changing the refractivity index of the environment depending on the wavelength of the light.

2.1.2. Reflectors

A reflector's working principle is based on reflection instead of refraction. In the most common design, parallel beams of light enter the tube by the top opening and travel through the whole telescope until they reach the bottom, where a parabolic (or spherical) mirror reflects the light to a secondary flat mirror mounted on the spider at the top of the telescope. This secondary mirror reflects light to the side eyepiece in which the focal point of the primary mirror is re-sent to the infinity. This design is commonly known as Newtonian telescope and it is one of the most popular reflecting systems used by amateur astronomers. The basic scheme of this type of telescope is shown in Figure 1b).

In comparison to refractor telescopes, reflectors do have the need of some maintenance, due to the fact that they use two (or more) mirrors and these need to be aligned, a process called *collimation* — which consists in the alignment of the two mirrors — must be done from time to time. Furthermore, eventual dust deposition over the primary mirror could occur, leading to a reflectivity loss, which affects the final quality image.

2.1.3. Catadioptric

Catadioptric telescopes are a combination of the characteristics of both refractors and reflectors because they combine the benefits of lenses and mirrors at the same time.

This type of telescope works by applying a correction to avoid aberrations to the beam of

light which then is reflected by the primary spherical mirror that can be found at the bottom of the tube. The beam then travels to the secondary mirror which finally reflects it to the eyepiece. It is for this reason that catadioptric telescopes are much more compact than refractors or reflectors.

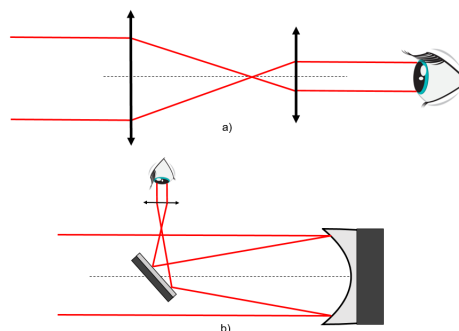

Figure 1. Working principle of a refracting (a) and reflecting (b) telescope. [5] [6] [7] [8]

2.2. Amateur 3D printed telescopes

3D printed telescopes are starting to gain popularity among the maker community. By looking at 3D printing websites like Thingiverse [9], many different projects with full guidelines to print and build a telescope using a 3D printer can be found.

As an example, one of the most popular projects is the *PiKon telescope* [10], a reflector telescope that uses a Raspberry Pi [11] to capture images of the observed objects. A picture of the telescope is shown below.



Figure 2. PiKon telescope, extracted from PiKon Website. [10]

3. Design and specifications

For this project, a Newtonian design was chosen. For the optical specifications of the system, a 152 mm (6 inches) aperture was chosen. Since a 762 mm focal length concave mirror with such aperture diameter was available, thus, an F5 Newtonian telescope design was finally proposed.

With these main characteristics set, the next step is to begin designing the pieces needed to build the telescope using CAD. In our case, SolidWorks [12], a software developed by Dassault Systems was used. After some

iterations and a complete assembly of all the pieces, the CAD design resulted in the solid shown in Figure 3.

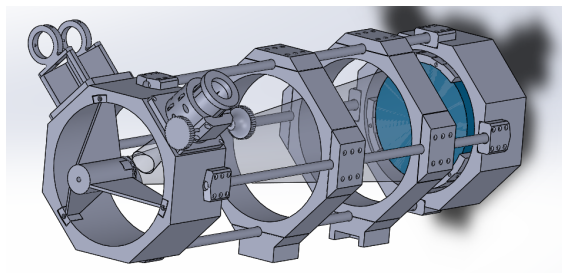

Figure 3. Telescope CAD.

Four parts of the design can be differentiated in Figure 3: the top cap —to the left—, the middle rings —the two rings at the centre of the assembly—, the bottom cap —to the right— and finally the bars that form the truss and unite all the pieces together. We will now go into further detail about each part.

3.1. Top Cap

The top cap is composed of five pieces itself: the top ring, the eyepiece holder (which in this case it is a Crayford focuser designed specifically for this telescope), the searcher support, the spider and the secondary mirror cell.

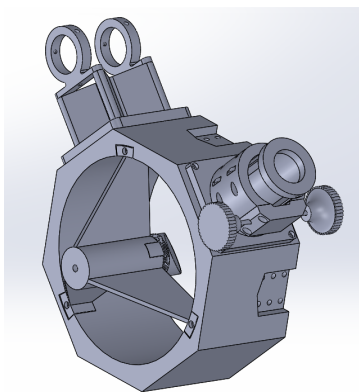

Figure 4. Top cap image with all the parts visible.

The most important piece of this part is the spider —centre-piece attached to the top cap—, which is basic for holding the secondary mirror cell to the body of the telescope. The design of the spider has to be done with special care, because it is required that it occupies the least amount of aperture possible, maximising the amount of photons that arrive at the primary mirror. All the pieces are fixed to the top ring with DIN912 M3 (different length depending on usage) screws that screw into inserts that are coupled to the ring using heat.

It can also be seen that both the eyepiece and searcher holders have many screw holes. That is to ensure the integrity of the system in case the final user would like to strap a camera to take pictures through the eyepiece.

3.2. Middle rings

The main purpose of the middle rings is to act as interfaces between the truss and the equatorial mount that will be used to point the telescope to the sky.

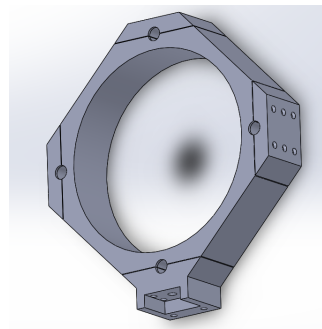

Figure 5. Middle ring, used as the interface between the mount and the telescope.

As it is shown in Figure 5, the middle ring's design presents three plates that screw into the main ring to ensure a perfect attachment to the truss of the telescope and a fourth plate which is different, that is used for fastening the telescope to the mount with the centre hole. Again, all screws fit into inserts put on the piece using heat.

3.3. Bottom cap

The bottom cap is the most intricate part to design because it contains moving pieces that will be used to collimate the main mirror.

Between the pieces that compose it, we can find the main mirror cell, the levers that compose the collimation system and the bottom cap which is the container of all the previous pieces.

This is a key part for the correct performance of the whole telescope because it contains the main part of the optical system as well as the alignment components.

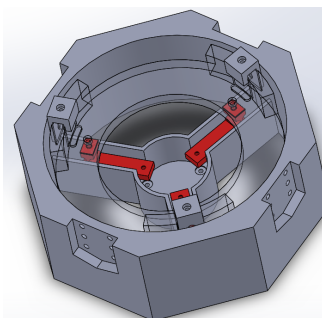

Figure 6. Bottom cap image. Main mirror cell is transparent so the collimation system can be visible.

As illustrated in the previous figure, the cell is supported by the red mechanisms. These form the collimation system as well as provide attachment to the main mirror cell both radial and longitudinally. These work as levers and are preloaded with a spring (not visible in the CAD - Figure 6 -). Figure 7 shows an image of a prototype of the collimation system.

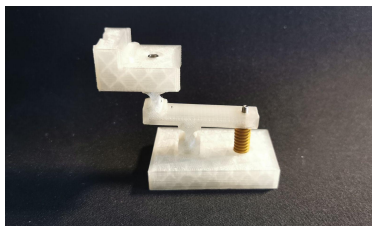

Figure 7. Prototype of the collimation system, intended to test structural integrity.

The *whiffletree* [13] (lever) is spring-loaded and acts the left arm of the lever when the screw on the right arm is actioned. This allows the main mirror cell to move upwards and downwards because of the flexibility given by the flexors.

Figure 6 shows how the levers are located inside guides, to ensure the structure is stiff enough to support the loads produced by the collimation system.

3.4. Truss bars

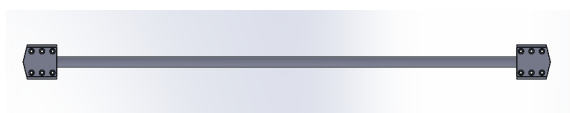

Figure 8. Truss bar with the interfaces to attach it to both the top and bottom caps.

The truss is composed of two different pieces, the bars and the interfaces to connect the top and bottom caps.

For the bars, 12 mm aluminium hollow bars are used, since aluminium gives rigidity to the truss and avoids overweight problems because of its lightness.

The interfaces are also 3D printed parts and are the key backbone of the structure. These are glued together with the aluminium bars using epoxy glue.

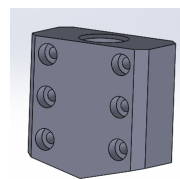

Figure 9. The interface of the truss in detail.

4. Educational applications

One of the aims of this project is mainly to introduce students of all ages into cosmos exploration, optical design of telescopes basis, and to provide a hands-on experience with 3D printing technologies, by means of building a telescope and testing its capabilities. This project is adequate both for upper course students, amateur astronomers and makers motivated with Astronomy. Focused on more experienced engineering students. For doing so, a proposal of activities is given.

Students could involve themselves in building the actual telescope by following the guidelines provided. The majority of the telescope is built by 3D printing the pieces and the non-3D printed materials are easily bought on the internet.

In addition to telescope fabrication and building, an introductory course into optics should be done in order to ensure a better understanding of the physics behind the telescope.

Moreover, as an extra activity, a space observation workshop using the telescope could be conducted.

The application of this project for different dissemination and educational activities, and the design of a workshop activity is a current ongoing work. At the final stage of the project, a complete free manual and theoretical background will be provided.

5. Results

At this point, the telescope has been built ensuring each piece was perfectly printed and everything fits together precisely and without critical loads. The final assembly is shown below.

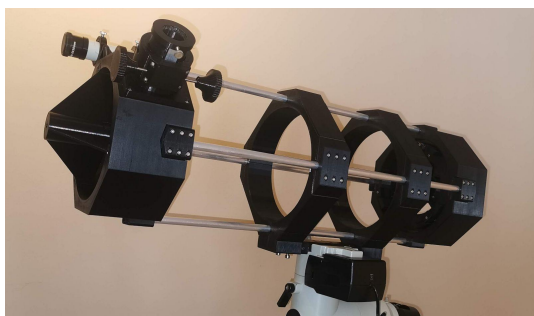

Figure 10. Final assembly of the telescope.

A commercial equivalent system is available thanks to COSMOS Mataró (an amateur Astronomy Association) to perform a comparison between the commercial and the custom 3D printed design. A preliminary comparison between both telescopes is shown in Figure 11. Authors are currently waiting for an optimal observation night, to obtain full results of the telescope's real resolution and capabilities.

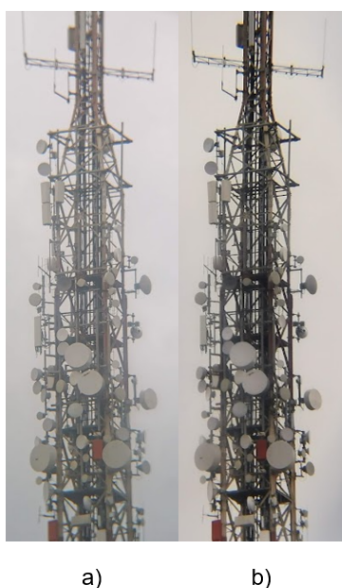

Figure 11. Image of a telecommunication tower obtained with the Meade LX75 telescope (a) from COSMOS Mataró, and with the 3D printed F5 Newtonian (b). Both images were obtained using the same equatorial mount.

Acknowledgements

This project has been partially funded by the Escola d'Enginyeria de Telecomunicacions i Aeroespacial de Castelldefels (EETAC) and the Physics Department of the Universitat Politècnica de Catalunya.

The authors acknowledge Diego Rodríguez from COSMOS Mataró for providing the commercial Meade telescope.

The corresponding author also wants to acknowledge his closest friends and family. Especially his brother, who has always been one of his biggest supports. And his fathers for always supporting him without ever losing their faith as well as for raising him as they did.

Also his uncle, Joan, to whom has always admired. For he served as an inspiration and encouraged him to become a great engineer as well as a better human.

References

- [1] BCN3D Website: <https://www.bcn3d.com> , last visited: 2nd March 2022.
- [2] 3DSystems Corporation Website: <https://www.3dsystems.com/>, last visited: 2nd March 2022.
- [3] RepRap Project Website: <https://reprap.org/wiki/RepRap>, last visited: 3rd March 2022.
- [4] Luis José Salazar-Serrano, Juan P. Torres, Alejandra Valencia, A 3D Printed Toolbox for Opto-Mechanical Components, *PLoS ONE*, 2016.
- [5] B. K. Johnson, Optics and Optical Instruments, *Dover Publications Inc.*, 1960.
- [6] M. Born, E. Wolf, Principles of Optics: Electromagnetic Theory of Propagation, Interference and Diffraction of Light, *Cambridge University Press*, 1999
- [7] W. J. Smith, Modern Optical Engineering, *McGraw-Hill*, 1998.
- [8] J. Mullaney, A Buyer's and User's Guide to Astronomical Telescopes and Binoculars, *Springer*, 2014.
- [9] Thingiverse Website: <https://www.thingiverse.com/> , last visited: 15th March 2022.
- [10] PiKon telescope Website: <https://pikonic.com/> , last visited: 15th March 2022.
- [11] Raspberry Pi Website: <https://www.raspberrypi.org/> , last visited: 15th March 2022.
- [12] SolidWorks Website: <https://www.solidworks.com/> , last visited: 11th March 2022.
- [13] J. H. Hindle, "Mechanical flotation of mirrors," in Amateur Telescope Making, Book One, *Scientific American*, 1945.