

# The hydrological function of organo-mineral soil grasslands in UK uplands

Stephanie Grace Bond

Submitted in accordance with the requirements for the degree of  
Doctor of Philosophy

The University of Leeds  
School of Geography

March 2022

## Declaration and author contributions

The candidate confirms that the work submitted is her own, except where work which has formed part of jointly authored publications has been included. The contribution of the candidate and the other authors to this work has been explicitly indicated below. The candidate confirms that appropriate credit has been given within the thesis where reference has been made to the work of others.

### **Chapter Two has appeared in publication as:**

Bond, S., Kirkby, M. J., & Holden, J. (2021). Upland grassland management influences organo-mineral soil properties and their hydrological function. *Ecohydrology*, 14(8), e2336.

The data that support the findings of Chapter Two are available at the University of Leeds data repository at <https://doi.org/10.5518/963>, reference number 10.5518/963.

Contributions: SB lead research design and methods, with all authors contributing to and approving its final form. SB made the overland flow sensors used and undertook all data collection, laboratory analysis and statistical assessment, and led the manuscript writing. All authors contributed to the interpretation of analysis, critical assessment of drafts and approved the final version.

### **Chapter Three has appeared in publication as:**

Bond, S., Kirkby, M. J., Johnston, J., Crowle, A., & Holden, J. (2020). Seasonal vegetation and management influence overland flow velocity and roughness in upland grasslands. *Hydrological Processes*, 34(18), 3777-3791.

The data that support the findings of this study are openly available in the University of Leeds data repository at <https://doi.org/10.5518/794>, reference number 10.5518/794.

Contributions: SB, MK and JH developed the flume concept based on earlier work by JH, and all authors collaborated to find an appropriate field site. Vegetation surveying was completed by JJ and SB, with further uplands habitat advice given by AC. SB undertook all

data collection, analysis and led manuscript writing. All authors contributed to the interpretation of analysis, critical assessment of drafts and approved the final version.

**Chapter Four is under consideration for publication, following an initial round of peer review and a request for revisions:**

Bond, S., Willis, T., Johnston, J., Crowle, A., Klaar, M.J., Kirkby, M. J., & Holden, J. (2022). The influence of land management and season on flood mitigation in two UK upland catchments. *Hydrological Processes*.

Contributions: SB and JJ developed model scenarios which were partially based on previous Calderdale modelling by TW, MJ Klaar and RSPB/Natural England sustainable farming goals. Scenarios were approved by all authors. All Swindale files were made by SB. Swindale rainfall-runoff gauge data were checked for suitability and an IDF curve produced by MJ Kirkby. Calderdale scenario mapping files were produced by SB and the DEM and base map by TW. All RefH storm events were produced by TW. Model calibration, validation, scenario runs, analysis and manuscript writing were led by SB. All authors contributed to the interpretation of analysis, critical assessment of drafts and approved the final version.

### **Thesis by alternative format rationale**

This thesis follows the University of Leeds Faculty of Environment protocol for the format and presentation of an alternative style of doctoral thesis including published material. The research questions of the project were investigated using a range of approaches, which made the presentation of the data chapters as three individual manuscripts appropriate. Two of the manuscripts have now been published, and the final one is under review. The main body of the thesis therefore consists of the published and submitted manuscripts. This is preceded by an introduction, which provides background information, reviews relevant literature, and outlines the aims and objectives of the work. A synthesis chapter, bringing together the findings of the three research papers and discussing them in the context of the research questions, concludes the thesis.

### **Copyright declaration**

This copy has been supplied on the understanding that it is copyright material and that no quotation from this thesis may be published without proper acknowledgement.

The right of Stephanie Bond to be identified as the author of this work has been asserted by her in accordance with the Copyright, Designs and Patents Act 1988.

© 2022 Stephanie Bond and the University of Leeds.

## Acknowledgements

This research was funded by a UK Natural Environment Research Council Industrial CASE PhD studentship, held by SB (grant reference: NE/P009085/1), with support from Natural England as CASE partner.

Firstly, thank you to my supervisors Joe Holden, Mike Kirkby, Jean Johnston and Alistair Crowle, for their patience, guidance, encouragement and support at all times.

Thank you to United Utilities and RSPB Haweswater, especially John Gorst, Lee Schofield and Spike Webb, for granting land access, land cover and flow gauging data, equipment storage, and providing invaluable guidance and encouragement. Thank you to Martin Roscoe at Boddington Playing Fields for providing access for flume testing.

Technical support from David Ashley, Santiago Clerici, Claire Goulsbra, Richard Grayson, Sarah Hunt, Anthony Parsons and Anthony Windross was greatly appreciated for equipment construction, maintenance and data collection.

Thank you to members of the River Basin Processes and Management cluster for always encouraging and challenging my research.

Thank you to Felicity Monger, Sarah Hunt, Emma Docherty, and Jess Williams for their assistance with fieldwork in all weathers. Thank you also to Tom Willis for his unwavering patience and support in helping with SD-TOPMODEL.

Finally, thank you to my wonderful family. Thank you to my parents Richard and Kathryn, my sisters Emma and Charley, and my nan Maureen - all of whom helped with fieldwork and gave their advice, support and love. Last but by no means least, thank you to my husband Jack. His belief in me and my research has been greater than I could have ever asked for. Thank you for being a listening ear, discussing ideas at all hours, for giving me confidence, and loving me unconditionally.

## Abstract

Despite the common global occurrence of grasslands on organo-mineral soils, very little is known about their associated hydrology. The UK uplands, as source areas for flood waters, are of considerable interest as locations that could be managed to reduce downstream river discharge peaks, and these areas are frequently covered with organo-mineral soil grasslands. This thesis examines how the management of UK upland organo-mineral grasslands influences soil properties, the production and control of overland flow, and river flow peak response to large storm events. Fieldwork was conducted in Swindale, Cumbria, assessing six different grassland types. Soils were highly permeable with significant differences in properties as the result of natural heterogeneity. Shallow soil depth was considered to be the dominant control over soil water storage, where soils frequently became waterlogged, producing overland flow up to 60% of the time. Land management, and seasonal growth and decay of vegetation, significantly influenced surface roughness, strongly affecting overland flow velocity. Winter overland flow velocity was significantly higher than in summer, and significant changes also occurred following vegetation cutting or grazing density alterations. Using empirical data, SD-TOPMODEL was used to predict river discharge peak size and timing in response to major storm events for different seasons and management scenarios in Swindale, and Calderdale, Yorkshire. Seasonality altered river discharge peaks by -5.5% to +2.2% and conservation management reduced peaks by up to 42% compared to the same storms occurring on recent land use. Overall, soil hydrological function was associated most with physical catchment characteristics, whereas grassland vegetation, and its influence on overland flow, was strongly associated with season and management. Where physical characteristics cannot be changed, grassland management was recommended as an effective means of 'slowing the flow' for flood mitigation, accounting for their role within a mosaiced upland landscape, management practicalities, climate change and other ecosystem services.

# Table of contents

<b>DECLARATION AND AUTHOR CONTRIBUTIONS .....</b>	<b>I</b>
<b>ACKNOWLEDGEMENTS.....</b>	<b>IV</b>
<b>ABSTRACT .....</b>	<b>V</b>
<b>TABLE OF CONTENTS .....</b>	<b>VI</b>
<b>LIST OF FIGURES .....</b>	<b>X</b>
<b>LIST OF TABLES .....</b>	<b>XII</b>
<b>CHAPTER 1. HYDROLOGY OF UPLAND ORGANO-MINERAL SOIL GRASSLANDS .....</b>	<b>1</b>
1.1 NATURAL FLOOD MANAGEMENT .....	1
1.2 ORGANO-MINERAL SOILS.....	4
1.2.1 Definitions.....	4
1.2.2 Distribution, land cover types and physical properties.....	9
1.3 OM SOIL HYDROLOGY.....	10
1.4 LAND MANAGEMENT .....	11
1.4.1 Grasslands and woodlands.....	11
1.4.2 Grassland hydrology.....	13
1.4.3 Land-use management within NFM.....	15
1.5 HYDROLOGICAL MODELLING.....	17
1.5.1 Model uncertainty.....	18
1.6 RESEARCH QUESTIONS .....	19
1.7 OVERVIEW OF THE METHODOLOGICAL APPROACH.....	20
1.7.1 Fieldwork approach.....	20
1.7.2 Modelling approach .....	22
1.8 ORGANISATION OF THE THESIS.....	26
1.9 REFERENCES .....	27
<b>CHAPTER 2. UPLAND GRASSLAND MANAGEMENT INFLUENCES ORGANO-MINERAL SOIL PROPERTIES AND THEIR HYDROLOGICAL FUNCTION .....</b>	<b>37</b>
2.1 ABSTRACT .....	37
2.2 INTRODUCTION .....	37

2.3	METHOD .....	39
2.3.1	Field site .....	39
2.3.2	Soil properties .....	44
2.3.3	Hydrological monitoring.....	44
2.4	RESULTS .....	48
2.4.1	Soil profile description .....	48
2.4.2	Soil properties .....	49
2.4.3	Hydrological monitoring.....	51
2.4.4	Storm events .....	56
2.5	DISCUSSION.....	59
2.6	CONCLUSION .....	62
2.7	REFERENCES .....	63

**CHAPTER 3. SEASONAL VEGETATION AND MANAGEMENT INFLUENCE OVERLAND FLOW VELOCITY AND ROUGHNESS IN UPLAND GRASSLANDS ..... 67**

3.1	ABSTRACT .....	67
3.2	INTRODUCTION .....	68
3.3	METHODS.....	73
3.3.1	Study site.....	73
3.3.2	Flume design .....	75
3.3.3	Data collection .....	76
3.3.4	Calculating surface roughness.....	78
3.3.5	Modelling expected roughness .....	79
3.4	RESULTS .....	81
3.5	DISCUSSION.....	88
3.5.1	Impact of grassland type on overland flow velocity .....	88
3.5.2	Seasonal influences on overland flow.....	88
3.5.3	Implications for modelling and NFM.....	91
3.6	CONCLUSIONS.....	93
3.7	REFERENCES .....	94

**CHAPTER 4. THE INFLUENCE OF LAND MANAGEMENT AND SEASON ON FLOOD MITIGATION IN TWO UK UPLAND CATCHMENTS ..... 99**

4.1	ABSTRACT .....	99
-----	----------------	----



4.2	INTRODUCTION .....	100
4.3	METHODS .....	103
4.3.1	Study sites .....	103
4.3.2	SD-TOPMODEL .....	108
4.3.3	Scenarios tested .....	115
4.3.4	Analysis methods .....	118
4.4	RESULTS .....	118
4.4.1	Scenario set 1. Seasonality.....	118
4.4.2	Scenario set 2. Land management .....	124
4.5	DISCUSSION .....	130
4.6	CONCLUSION .....	134
4.7	REFERENCES .....	136
<b>CHAPTER 5.</b>	<b>SYNTHESIS AND CONCLUSIONS .....</b>	<b>141</b>
5.1	CHAPTER SUMMARIES AND SECTION OUTLINE.....	142
5.2	THE INFLUENCE OF LAND MANAGEMENT ON SUBSURFACE HYDROLOGY .....	144
5.2.1	Management drivers of subsurface hydrology .....	144
5.2.2	Physical drivers of subsurface hydrology .....	145
5.3	THE INFLUENCE OF LAND MANAGEMENT ON SURFACE HYDROLOGY .....	147
5.3.1	Vegetation structure .....	147
5.4	THE INFLUENCE OF SEASONALITY .....	151
5.4.1	Surface roughness.....	151
5.4.2	Climate and antecedent conditions .....	152
5.5	KEY IMPLICATIONS FOR NFM .....	153
5.5.1	Grassland versus woodland .....	153
5.5.2	Seasonal implications.....	154
5.5.3	The effectiveness of OM grasslands at the catchment scale .....	154
5.5.4	Ecosystem services .....	155
5.6	LIMITATIONS AND RECOMMENDATIONS FOR FUTURE RESEARCH .....	156
5.6.1	Fieldwork .....	156
5.6.2	Modelling.....	157
5.6.3	Future research recommendations .....	161
5.7	FINAL CONCLUSIONS.....	162
5.8	REFERENCES .....	163

<b>APPENDIX A. SUPPORTING INFORMATION FOR CHAPTER TWO.....</b>	<b>169</b>
A.1 SOIL PROPERTIES DATA.....	169
A.2 LIST OF ABBREVIATIONS USED IN CHAPTER TWO .....	171
A.3 SOIL MOISTURE DATA .....	172
A.4 RAINFALL AND OVERLAND FLOW DATA.....	175
<b>APPENDIX B. SUPPORTING INFORMATION FOR CHAPTER THREE.....</b>	<b>176</b>
B.1 LIST OF ABBREVIATIONS USED IN CHAPTER THREE .....	176
B.2 VEGETATION SURVEYS.....	177
B.3 RHODAMINE CONCENTRATION AND FLUOROMETER BREAKTHROUGH CURVES.....	180
<b>APPENDIX C. SUPPORTING INFORMATION FOR CHAPTER FOUR.....</b>	<b>183</b>
C.1 SD-TOPMODEL PARAMETER DERIVATION .....	183
C.2 SWINDALE LAND USES AND MODEL PARAMETERS .....	188
C.3 CALDERDALE LAND USES AND MODEL PARAMETERS .....	208
C.4 SWINDALE IDF CURVE .....	233
<b>APPENDIX D. INITIALISMS, ACRONYMS, AND ABBREVIATIONS USED IN THIS THESIS</b>	<b>234</b>

## List of figures

Figure 1.1: Organo-mineral soil distribution for England and Wales.....	10
Figure 2.1: Swindale location and location of all physical soil sampling and soil moisture (SM in legend) and overland flow (OLF in legend) sensors.....	42
Figure 2.2: Schematic of the sensor installation.....	47
Figure 2.3: Representative soil profiles for the Upper (left) and Lower (right) slope sampling locations.....	48
Figure 2.4: Soil properties for Bracken, Excluded (Rank Grassland), Good Grazing, Hay Meadows and Rough Grazing habitats.....	50
Figure 2.5: Soil moisture boxplots comparing habitats within each slope location by matched-records.....	52
Figure 2.6: Relative overland flow presence per habitat per month.....	55
Figure 2.7: Rainfall, soil moisture (5 cm depth only) and presence of overland flow for a July 2019 storm.....	57
Figure 2.8: Rainfall, soil moisture (5 cm depth only) and presence of overland flow for a December 2019 storm.....	58
Figure 3.1: Overland flow hillslope flume design .....	76
Figure 3.2: Flume set up showing visual habitat change seasonally.....	77
Figure 3.3: Seasonal overland flow velocity for Rank Grassland, Rushes, Hay Meadows and Low-density Grazing.....	83
Figure 3.4: The relationship between discharge and velocity, comparing theoretical to calculated Swindale values.....	86
Figure 3.5: Calculated relative roughness ( $k^*$ in equation 3.12), showing seasonality for Swindale.....	87
Figure 4.1: Swindale catchment and current land cover.....	104
Figure 4.2: Upper Calderdale catchment and current land cover.....	105
Figure 4.3: Final calibration model runs for Swindale (A) and Calderdale (B).....	113
Figure 4.4: Swindale validation using Storm Ciara.....	114
Figure 4.5: Calderdale validation using a storm from 26 <sup>th</sup> December 2015.....	114
Figure 4.6: The influence of seasonality on total runoff and overland flow for runoff peak and timing in Swindale.....	121
Figure 4.7: The influence of seasonality on total runoff and overland flow for runoff peak and timing in Calderdale.....	122
Figure 4.8: A comparison of the percentage difference in overland flow peak from the baseline (annual average) seasonality scenario for Swindale and Calderdale.....	123
Figure 4.9: The influence of management on total runoff and overland flow flood peak and timing for ReFH storm events in Swindale.....	127
Figure 4.10: The influence of management on overland flow flood peak and timing for ReFH storm events in Calderdale.....	128

Figure 4.11: A comparison of the percentage difference in overland flow peak from the baseline scenario for Swindale and Calderdale.....	129
Figure 5.1: Vegetation roughness based on (measured and assumed) annual average overland flow velocity measurements by Bond et al. (2020), Holden et al. (2008) and Monger et al. (2022).....	149
Figure A1.1: The correlation between soil properties including the correlation coefficient, R2 and the Spearman’s rank p value.....	170
Figure A3.1: Soil moisture separated by sensor depth and habitat for the Upper Slope site .....	172
Figure A3.2: Soil moisture separated by sensor depth and habitat for the Lower Slope site .....	173
Figure B3.1: Standards concentration of rhodamine dye in deionised water.....	181
Figure B3.2: Example breakthrough curves for each flow rate from the November data collection.....	182
Figure C2.1: Baseline land use for Swindale.....	190
Figure C2.2: Map for Scenario S2_1.....	195
Figure C2.3: Map for Scenario S2_2.....	197
Figure C2.4: Map for Scenario S2_3.....	199
Figure C2.5: Map for Scenario S2_4.....	201
Figure C2.6: Map for Scenario S2_5.....	203
Figure C2.7: Map for Scenario S2_6.....	205
Figure C3.1: Baseline land use for Calderdale.....	210
Figure C3.2: Map for Scenario C2_1.....	218
Figure C3.3: Map for Scenario C2_1a.....	220
Figure C3.4: Map for Scenario C2_2.....	222
Figure C3.5: Map for Scenario C2_3.....	224
Figure C3.6: Map for Scenario C2_4.....	226
Figure C3.7: Map for Scenario C2_5.....	228
Figure C3.8: Map for Scenario C2_6.....	230
Figure C4.1: IDF curve for Mickleden gauge near Swindale.....	233

## List of tables

Table 1.1: Organo-mineral soil types.....	6
Table 2.1: Grassland habitats in Swindale.....	43
Table 3.1: Upland grassland habitats studied in Swindale.....	74
Table 3.2: Count, velocity, flow depth, Darcy-Weisbach roughness, slope and relative roughness summary table for all flume data.....	82
Table 4.1: Swindale location, area, mean slope, elevation, climate and current catchment land covers, including their CEH 2015 designated land cover, area, grazing status and primary underlying soil type.....	106
Table 4.2: Calderdale location, area, mean slope, elevation, climate and current catchment land covers, including area, grazing status and primary underlying soil type.....	107
Table 4.3: Modelled storm events and their rainfall intensity.....	109
Table 4.4: Parameter sources and application to the baseline model.....	111
Table 4.5: Calibration ranges, chosen calibrated values and Nash-Sutcliffe ranges for Swindale and Calderdale.....	112
Table 4.6: Seasonality and management scenarios tested.....	117
Table A2.1: Abbreviations used in Chapter Two.....	171
Table A2.2: Habitat abbreviations used in Chapter Two.....	171
Table A3.1: Mean, standard deviation and number of records of soil moisture measured as part of the matched records analysis and as part of the complete dataset.....	174
Table A4.1: Rainfall and percentage presence of overland flow for the whole dataset and within the matched-records analysis.....	175
Table B2.1: Species present and their mean abundance for Hay meadows, Rank Grassland and Low-density grazing in Swindale, UK.....	178
Table C2.1: Land uses in Swindale.....	188
Table C2.2: Baseline map parameter values for each land use in Swindale.....	191
Table C2.3: Kv parameter value and relative velocity values for each land use in Swindale.....	193
Table C2.4: Parameters for management scenario S2_1.....	196
Table C2.5: Parameters for management scenario S2_2.....	198
Table C2.6: Parameters for management scenario S2_3.....	200
Table C2.7: Parameters for management scenario S2_4.....	202
Table C2.8: Parameters for management scenario S2_5.....	204
Table C2.9: Parameters for management scenario S2_6.....	206
Table C3.1: Kv and K values for the Calderdale baseline map (current land use).....	211
Table C3.2: In and m values for the Calderdale baseline map (current land use).....	212
Table C3.3: Kv Parameter value and relative velocity values for each land use in Calderdale.....	215
Table C3.4: Seasonal In values and their corresponding map values for Seasonality scenarios in Calderdale.....	216
Table C3.5: Parameters for re-wilding scenario C2_1.....	219

Table C3.6: Parameters for re-wilding scenario C2_1a.....	221
Table C3.7: Parameters for re-wilding scenario C2_2.....	223
Table C3.8: Parameters for re-wilding scenario C2_3.....	225
Table C3.9: Parameters for re-wilding scenario C2_4.....	227
Table C3.10: Parameters for re-wilding scenario C2_5.....	229
Table C3.11: Parameters for re-wilding scenario C2_6.....	231
Table D.1: Abbreviations used in this thesis.....	234

# Chapter 1. Hydrology of upland organo-mineral soil grasslands

As extreme weather events and flooding become increasingly common with advancing climate change (Lowe et al., 2018), management of upland hydrological systems has been considered important for mitigating downstream flood risk (Marshall et al., 2009, Murphy et al., 2020). Organo-mineral soil grasslands, as part of mosaiced landscapes, are often found in upland settings globally (Bol et al., 2011, Joint Nature Conservation Committee, 2011, Holden et al., 2007). These systems can be subject to many different forms of land use and management and have great potential to be highly adaptable in favour of creating a practical but climate-resilient environment (Meyles et al., 2006, Ellis et al., 2021, Freeman, 2020).

This introductory chapter seeks to provide context for this thesis by reviewing relevant literature. Firstly, an introduction to natural flood management (NFM) is given with focus on upland catchments. Following this, organo-mineral (OM) soils are defined, outlining their importance and potential role in upland hydrology. The role of land management in controlling runoff through storing water and 'slowing the flow' is discussed, especially for grasslands, including their relation to OM soil properties and the potential influence of surface roughness. Next, hydrological modelling is considered as a means of assessing the influence of upland management impact on catchment hydrology. Finally, the thesis aims and objectives are addressed, followed by an overview of the methodological approach and thesis chapters.

## 1.1 Natural flood management

The frequency of flooding is rising globally, driven by increasingly common extreme weather events caused by climate change (Winsemius et al., 2016, Hirabayashi et al., 2013, Hirabayashi et al., 2021). Floods were estimated to account for 44% of disasters worldwide between 2000 and 2019, affecting 1.6 billion people and costing an estimated 651 billion US\$ (CRED and UNDRR, 2020). Individual events can be especially catastrophic, and, in the UK, the winter storms of 2015-16 are estimated to have cost £1.6 billion (Environment Agency, 2018). Since 2015, £2.6 billion has been invested in UK flood defences, and an

estimated £3 billion more is set to be spent by 2027 to protect the 5.2 million properties at risk (National Audit Office, 2020).

Traditional flood defence methods use 'hard engineering' techniques such as dams, barriers or channels to redirect water or store water away from vulnerable locations. Costs are often high and can be detrimental to natural processes such as fish migration which is affected by changes to channel depth, velocity, vegetation and barriers (Juárez et al., 2021). In recent years, NFM has been used as a cost-effective and nature-friendly alternative to supplement traditional flood management (Aerts, 2018).

The term 'NFM' is primarily used in the UK. NFM is common in other countries although sometimes referred to by alternative names, which may have marginally different definitions. Common alternative names for NFM include 'Catchment-based approach' (CBA), 'Working with natural processes' (WWNP), 'Nature-based flood protection' (NBFP), 'Nature-based solutions' (NBS) and 'Ecosystem-based Disaster Risk Reduction (Eco-DRR)'. Although not often strictly regarded as NFM, Sustainable Urban Drainage (SuDs) and the Sponge City concept (Chan et al., 2018) use NFM principles and may be included within a broader NFM definition.

The Scottish Environment Protection Agency (SEPA) defined NFM as involving *"techniques that aim to work with natural hydrological and morphological processes, features and characteristics to manage the sources and pathways of flood waters. These techniques include the restoration, enhancement and alteration of natural features and characteristics, but exclude traditional flood defence engineering that works against or disrupts these natural processes"* (Forbes et al., 2015). Simply, NFM aims to work with natural processes to reduce the frequency at which water levels are above critical through manipulating river or catchment characteristics to 'slow the flow', ultimately aiming to increase infiltration, store water and reduce runoff velocity (Lane et al., 2007, Lane, 2017, Environment Agency and cbec, 2017). These can be achieved in three ways:

1. Increasing attenuation on the hillslope through natural management of hillslope connectivity and preferential flow pathways, ultimately increasing the percentage of runoff which drains via slower mechanisms.



2. Increasing upstream storage and flow resistance during extreme storm events so that peak flows are relatively unaffected by the increased volume of water on the hillslopes.
3. Increasing attenuation for water within the drainage network through channel manipulation.

Research in this thesis focuses on the first of these techniques.

In the UK, NFM was widely adopted following *The Pitt Review* (Pitt, 2008), which recommended catchment flood management should be developed to work with natural processes (Defra, 2012). NFM approaches have been adopted by Defra and the Environment Agency (Environment Agency, 2010, Defra, 2009, Defra and Environment Agency, 2011, National Audit Office, 2020, Defra and Coffey, 2017); the Welsh and Scottish Governments (Welsh Government, 2014, Scottish Government, 2010, Scottish Environmental Protection Agency, 2015); the European Union (WG POM, 2014); and also by private sector organisations such as the Chartered Institute for Water and Environmental Management (CIWEM) and the Construction Industry Research and Information Association (CIRIA) (Environment Agency and cbec, 2017, Grant, 2011, McIntyre and Thorne, 2013). Each of the above policies published by institutions or governing bodies encourages NFM as holistic, sustainable and affordable, which can be utilised instead of, and alongside, traditional flood alleviation methods.

As well as flood mitigation, NFM is increasingly recognised as potentially providing multiple ecosystem services through working with natural processes. These may include water quality and sediment control, carbon storage, biodiversity and recreational activities (Environment Agency and cbec, 2017). The EU Natural Water Retention Measures (NWRM) policy (WG POM, 2014) specifically relates NWRM methods to the Water Framework Directive, Flood Directive and Habitats and Birds Directive; and supports the Seventh Environmental Action Programme (7EAP), Natura2000 management plans and EU 2020 Biodiversity Strategy. Integrated catchment management, including NFM, is also expected to be written into the Environmental Land Management Scheme (ELMS) following Brexit

and the end of the Common Agricultural Policy (CAP) in the UK (National Audit Office, 2020, Klaar et al., 2020). At a global scale, NFM methods have been recognised as potential contributors to global targets including the Aichi Biodiversity Targets (WG POM, 2014, Convention on Biological Diversity, 2010), and are used globally by non-governmental, collaborative and business organisations.

Globally, NFM is most often applied in upland regions, which are the most vulnerable to flash-flooding events but also have the most potential for 'storing' and 'slowing' flows. In the UK, uplands are the source of 68% of all freshwater (Van der Wal et al., 2011) and have experienced greater increases in precipitation in comparison to lowland locations (Burt and Holden, 2010). However, <6 % of UK-based NFM schemes have any type of monitoring and <25% provide evidence of effectiveness based on observational data (Hankin et al., 2017, Kay et al., 2019). It is therefore essential that the mechanisms surrounding upland hydrology are understood so runoff can be managed effectively.

## 1.2 Organo-mineral soils

### 1.2.1 Definitions

Internationally there is little recognition of the term 'organo-mineral soil'. This is partially a factor of soil classification, in which many countries now use the World Reference Base (WRB), whereas OM soils have traditionally been identified using the soil classification system for England and Wales (Avery, 1980). The WRB uses diagnostic horizons to categorise soil types into 32 reference soil groups (IUSS Working Group WRB, 2014), however it does not record the depth of the organic surface layer (Bruneau and Johnson, 2014) on which the OM definition is partially based. In the UK, OM soils are more clearly defined, although specifics vary by country. OM soils typically comprise a surface organic layer  $\leq 40$ cm deep ( $\leq 50$ cm deep in Northern Ireland and  $10 \leq 50$  cm deep in Scotland), covering mineral horizons beneath or directly overlaying rock (West, 2011, Holden et al., 2007, Smith et al., 2007b). Unlike peat soils, which have an even soil organic carbon (SOC) distribution, OM SOC is concentrated within the top 30 cm of the soil profile (Holden et al., 2007). In addition to this, the soil organic matter (SOM) content of the surface horizon

should have a minimum of 20% organic matter in Scotland, England and Wales, and a minimum of 35% in Northern Ireland (Joint Nature Conservation Committee, 2011) to be classed as OM. In many parts of the UK, the term OM is used inter-changeably with 'shallow peaty soils', and peat soils are referred to as 'deep peat'. Morphologically, OM soils have persistent waterlogging that retards organic matter decomposition and allows incipient peat development. The peaty layer is shallow and not permanently saturated, which allows bioturbation to mix some mineral soil up into the organic soil.

Defra (Bol et al., 2011) defined OM soils in the following way, stating that they should be rich enough in organic matter to have:

*(1) A Humose topsoil >15 cm thick;*

*(2) A Peaty loam or peaty sand topsoil (<20% organic carbon) >15 cm thick; OR*

*(3) Peat (loamy, sandy, fibrous, semi-fibrous or amorphous) <40 cm thick starting at or near the surface, or <30 cm thick where the peat lies directly on bedrock.*

Using the above definitions, three categories were identified which incorporate 17 soil types as defined by the Soil Classification System for England and Wales, based on Avery (1980): Well-drained, Podzol and Gley OM soils. Within these categories, different OM definitions include and exclude different soil types. For example, in Scotland, humic rendzinas, humic brown podzols, typical gley podzols, stagnogley podzols, pelo-alluvial gleys, typical humic-alluvial gleys, and typical humic-sandy gley soils are not categorised as 'OM' (Smith et al., 2007b, Bol et al., 2011). In other classifications, acid brown earth soils are included (Palmer et al., 2014).

A summary of OM soil types are summarised in Table 1.1 alongside their wetness class and WRB soil group equivalent.

Table 1.1: Organo-mineral soil types. Table partially modified from Bol et al. (2011), from which that study combined information from (1) Hodgson (1997) and (2) Mackney et al. (1983) to form this table. Additions to this table from this report are the columns 'SSG description' and 'WRB soil group', based on (3) Scotland's Soils (2017), (4) Cranfield University (2018) and (5) Avery (1990). The soil 'Acid Brown Earth' has also been added to the table, categorised as an OM soil by Palmer et al. (2014). Soils highlighted in a peach colour are included under the definition of OM soils in the report by Bol et al. (2011) but not by Smith et al. (2007b) – this excludes this acid brown earth soil type, highlighted in blue, which is not classed as OM by either Smith et al or Bol et al. Wetness class describes the depth and duration of waterlogging in the soil profile where I is not wet within 70cm depth for more than 30 days in most years and VI is almost permanently saturated to 40cm depth for >335 days in most years (Hodgson, 1997).

Category	Description	Wetness class (1)	Soil subgroup (SSG) name (2)	SSG code	SSG description (3, 4, 5)	SSG overarching WRB soil group equivalent (4)
1 – Well drained	Freely and moderately well drained with humose or thin (<40cm thick) peaty surface horizon (topsoil)	I, II	Humic rankers	3.11	Shallow soils >10cm, with a distinct humose or peaty surface horizon and a thin, grey, leached E horizon <5cm thick. Usually over bedrock. Non-calcareous.	Leptosol
			Humic Rendzinas	3.41	Shallow soil >10cm, Humose mineral topsoil, any subsurface horizons <5cm, overlying chalk or rubble near the surface. Usually over bedrock. Calcareous.	Leptosol
			Humic Brown Podzolic soils	6.12	Podzol with a humose topsoil, a dark brown, iron-rich subsoil which has no overlying bleached layer and is unmottled	Umbrisol
			Humo-ferric Podzols	6.31	A non-hydromorphic, well-drained podzol with a bleached subsurface horizon, no thin ironpan with iron-rich parent materials. Black/brown humus surface.	Podzols
			Acid Brown Earths	5.4	Non-alluvial loamy soil with non-calcareous subsoil and insignificant clay enrichment	Cambisols

2 - Podzols	Poorly drained Podzols with humose or thin (<40cm thick) peaty surface horizon	IV, V, VI	Ferric Podzols	6.33	Podzol with a well-drained bleached subsurface, no thin ironpan and a dark brown/ochreous iron-rich horizon below the bleached horizon which contains little humus	Podzols
			Typical-gley Podzols	6.41	Podzol with bleached subsurface horizon over a dark humus-rich subsoil horizon, underlain by a grey-blue, possibly mottled horizon due to periodic waterlogging.	Podzols
			Stagnogley Podzols	6.43	Podzol with a bleached subsurface horizon over a dark humus/iron enriched subsoil. Periodically waterlogged to produce a mottled, greyish horizon. Similar to the typical-gley podzol with a slowly permeable subsoil.	Podzols
			Ironpan Stagnopodzols	6.51	Podzol with a peaty surface layer up to 40cm thick (in undisturbed profiles) with a sinuous thin ironpan below an eluvial horizon which is rarely mottled. Horizon below the pan does not often show evidence of gleying.	Podzols
			Humus-ironpan Stagnopodzols	6.52	Podzol with a peaty topsoil, and periodically water-logged bleached subsurface horizon over an iron-rich subsoil. Differs from ironpan stagnopodzols due to a dark coloured Bh horizon above the ironpan.	Podzols
			Ferric Stagnopodzols	6.54	A stagnopodzol with a grey eluvial horizon over an ochreous Bs horizon with no thin, continuous ironpan. Seasonally waterlogged peaty surface causes some gleying in the mineral horizons	Podzols

3 – Gley soils	Poorly drained Stagnohumic Gleys, Pello-alluvial Gleys and Humic Gley soils with humose or thin (<40cm thick) peaty surface horizon	V, VI	Stagnohumic Gley soils	7.21	Surface-water gley soil with a humose or peaty topsoil, intermediate between stagnogleys and peat soils. Often mottled within 40cm of the surface.	Stagnosols
			Pello-alluvial Gley soils	8.13 (a and f only)	Groundwater gley. Non-humic gley soil in non-calcareous clayey alluvium which lacks acid-sulphate characteristics. Alluvium >30cm thick.	Gleysol
			Typical Humic-alluvial Gley soils	8.51	Groundwater gley. Found in non-calcareous or decalcified alluvium. Humose or peaty topsoil. Loamy or clayey mineral sub-surface horizons, lack of acid-sulphate characteristics. Alluvium >30cm thick.	Gleysol
			Typical Humic-sandy Gley soils	8.61	Groundwater gley. Humose or peaty topsoil with a greyish sandy horizon beneath. Little/no mottling. Non-calcareous subsoil. Intermediate between sandy gley and lowland peat soils.	Gleysol
			Typical Humic Gley soils	8.71	Groundwater gley soil. Non-alluvial loamy or clayey soil with a humose or peaty topsoil. Non-calcareous subsoil and a lack of clay enrichment.	Gleysol
			Argillic Humic Gley soils	8.73	Groundwater gley soil. Non-alluvial loamy or clayey soil with a humose or peaty topsoil. Clay-enriched subsoil.	Gleysol

### 1.2.2 Distribution, land cover types and physical properties

Using the description as set out by Defra (Bol et al., 2011), OM soils cover 30.5% of Europe. However, due to its calculation using over-arching WRB groups as opposed to soil subgroups groups, this percentage will include some soils which may not be OM. Since OM soils are defined using SOM depth, the use of the WRB system makes it difficult to assess OM distribution worldwide. As such, there are currently no maps available showing the exact distribution of organo-mineral soils, for any soil categorisation method, outside of the UK.

Within the UK, accounting for individual countries' definitions, OM soils cover 10.5% of England and Wales (of which 58.5% is in uplands) and 50% of Scotland and Ireland (Bol et al., 2011). Other estimates of coverage include 17.3% OM cover (Smith et al., 2007b) and 8% cover (Holden et al., 2007) in England and Wales. Comparatively, peat soils cover approximately 3.3 % of England and Wales (Holden et al., 2007). The distribution of OM soils for England and Wales, as defined by Bol et al. (2011) is shown in Figure 1.1.

Again using the definition by Defra (Bol et al., 2011), the types of land cover associated with OM soils can be identified. In upland England, 29.4% of OM soils underlie grasslands, 9.5% underlie heath and montane habitats and 1.8% underlie wetlands; in comparison, in Wales, 52.1% underlie grassland, 15.0% heath and montane habitat, 13.6% forest and 1.1% wetlands (Bol et al., 2011).

Although a precise definition of OM soils prevents a detailed understanding of their spatial extent, the environmental significance of OM soils and the subsequent need to protect them is becoming increasingly documented. In the UK, approximately 30% of SOC is held in peat soils and a further 22% in OM soils (Reynolds, 2007, Bradley et al., 2005). In general, the top 15 cm of soil is considered to be most vulnerable to land-use change (Bol et al., 2011), which is estimated to be the cause of 15% of total greenhouse gas emissions in Scottish organic soils (Smith et al., 2007b). If land use changes are made as part of NFM strategy, the vulnerability of surface OM soils and any potential influence on their hydrology or carbon sequestration must be considered before management is applied.

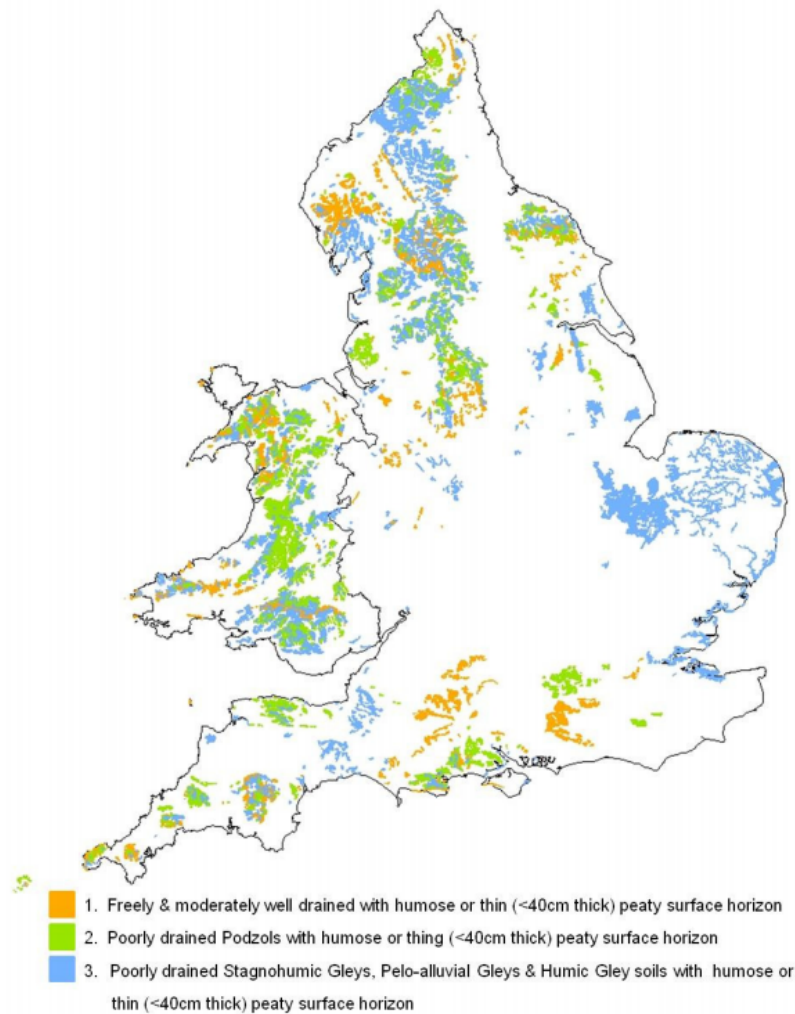

Figure 1.1: Organo-mineral soil distribution for England and Wales. From Bol et al. (2011) based on their definition of organo-mineral soils which are highlighted in a peach colour in Table 1.1.

### 1.3 OM soil hydrology

Globally, there is little data on the hydrological functioning of OM soil types compared to more extensively researched organic peat soils. Overland flow is often produced in peatlands which are almost permanently waterlogged, holding 90-95 % water by mass, and therefore have little storage capacity (Holden et al., 2007, Holden, 2005). Because of this, up to 80% of hillslope runoff from peat can be in the form of saturation-excess overland flow (Holden and Burt, 2003), producing flashy hydrographs due to rapid runoff response.

Organo-mineral soils, which are more widely varied in soil structure and permeability, have a larger spatial extent (including a larger range of land covers and managements), and so are



likely to have a much greater range of flow types and mechanisms. Since OM soils are likely to be more transient in their water storage, they may have a higher potential for flood mitigation than peat soils which remain saturated for much of the year.

In uplands, the position of OM soils in a catchment may also be important to runoff formation. Peat soils are prominent at the head and base of the catchment on relatively shallow slopes whereas OM soils are more likely to form in the mid-catchment on steeper slopes (Jarvis et al., 1984, Bol et al., 2011). Steep slopes are more likely to have thin soils, and therefore act as sources of runoff as opposed to water storage locations (Van der Wal et al., 2011). Where soils are shallow, they saturate quickly even with high infiltration rates, producing surface runoff. In addition, mid-slope pastures are commonly compacted in UK catchment headwaters (Murphy et al., 2020), which can induce infiltration-excess overland flow.

Organo-mineral soils also have lower organic matter content and depth than peat soils, however their SOM content may still have a large hydrological impact. Organic matter can absorb up to 20 times its weight in water (IPCC, 2013, Reicosky, 2005), and for every 1% increase in SOM, water retention capacity can increase by 3.7% (Hudson, 1994). Therefore, if not waterlogged, a deeper organic surface horizon enables more water storage (organo-mineral soils can have a surface organic horizon up to 40cm deep). However, with high SOM content at the surface and fluctuating water tables, OM soils may retain water and therefore produce saturated-excess overland flow regularly. Similarly, if the surface SOM dries, it may harden and produce hydrophobic conditions which significantly reduce infiltration and encourage infiltration-excess overland flow in storm events. This is a known problem for degraded peat soils (Allott et al., 2019) which may also occur in OM soils, especially in summer drought conditions or following fire (Olorunfemi et al., 2014).

## 1.4 Land management

### 1.4.1 Grasslands and woodlands

The most common land use overlaying OM soils is grassland, which accounts for 69% of global agricultural land (Wood et al., 2000) including 60% of the UK (of which 46 % is 'semi-

natural grassland' (Defra, 2016)). Most OM soils are associated with semi-natural environments (Lilly et al., 2009) and in upland England, OM soils underlie 29% of all rough grassland, 35% of all bracken and 33% of all acid grasslands (Bol et al., 2011). In comparison, woodland covers 13.2 % of the UK of which approximately half are native woodlands and half plantations; only 2.5 % of woodlands are ancient woodland (Reid et al., 2021). OM soils underlie approximately 3.9% of coniferous forests in upland England with no significant coverage of broadleaf woodlands (Bol et al., 2011).

Despite their large extent, grasslands have been understudied in comparison to woodlands for which the links between hydrologic function and flood risk are better understood (Ellis et al., 2021, Peel, 2009). Comparison studies between the two land uses suggest that woodlands have significantly higher permeability (Archer et al., 2012, Archer et al., 2013), greater water storage, lower discharge and surface runoff (Monger et al., 2022, Chandler et al., 2018), greater evapotranspiration and interception rates (Madani et al., 2018), and higher surface roughness (Chow, 1959, Thomas and Nisbet, 2007). However, the time taken to establish woodland may influence its use for NFM, especially in the short term.

Modelling by Revell et al. (2021) found grassland to reduce flood peaks by 10-32 % more than deciduous woodland in winter and 0.5-6 % in summer; this was attributed to the relative age of the woodland studied which was up to 15 years old. Although more research is required regarding the relationship between newly established woodlands, grasslands of varying types and their role in NFM, the work by Revell et al. (2021) demonstrates the importance of grassland not only as a significant land use in its own right, but also as a stopgap whilst woodland develops. The high variety of grassland types, their uses and their management mean there is high potential for NFM, especially where woodland is untenable or short-term relief is required. Grasslands, for example, have been found to 'recover quickly' from grazing where within five years the hillslope hydrology and vegetation can resemble that of a grassland with over 40 years no grazing (Holden et al., 2007). Other studies suggest grassland recovery from grazing may be longer (Gifford and Hawkins, 1978) (with some estimates of recovery taking between 48 and 62 years (Marrs et al., 2020, Marrs et al., 2018)), or woodland establishment shorter (Murphy et al., 2020); in either case, the use of grasslands in NFM should not be discounted. As the primary land use overlying OM

soils, and an understudied land use for NFM, this thesis primarily focuses on grassland hydrological function in downstream flood risk.

#### 1.4.2 Grassland hydrology

Soil hydrologic functioning is enhanced or reduced as the result of land management; therefore, land use change can be considered a subset of NFM. Land-use changes alter antecedent conditions, flow paths and flow velocities, hillslope water storage, and soil structure (Rogger et al., 2017). Typically, soil properties and vegetation changes are the two main land management influencers of hydrology in uplands, ultimately contributing to the runoff rate and volume in downstream flow (and therefore flood management). However, the extent of land management influence on downstream flood peaks is still widely debated.

Most often, upland grasslands are managed to support livestock. Livestock strongly influence the abundance of vegetation present, but also the spatial heterogeneity of vegetation, thus affecting biodiversity and ecosystem processes (Adler et al., 2001). Hydrologically, the impacts of compaction from livestock grazing typically coincide with vegetation impacts due to livestock feeding and trampling habits. Soil structural damage from trampling typically occurs to shallow depths of 0-10 cm and is often localised around livestock feeders and water troughs, and around gateways and regularly used tracks (Drewry, 2006, Clarke et al., 2008). Livestock, which feed on the vegetation, alter vegetation community composition through selective grazing and soil compaction which reduces soil porosity. Reduced pore space stifles plant growth by restricting access to moisture, nutrients and oxygen (Clarke et al., 2008, Gowing et al., 2002). Affected soils tend to support fewer plant species (Roovers et al., 2004), although there is a large range in vegetation resilience to compaction and waterlogging (Wright et al., 2017). Vegetation growth increases transpiration and water uptake from the soil, which is not just restricted to the surface soils if root penetration is deep (Soulsby, 1993). Vegetation also insulates soils from heat, drought and freezing temperatures, which can produce impermeable conditions (Sansom, 1999). Therefore, as much as the soils influence the viability of growth, the species present also impact on soil structure, altering the root density, root depth and organic

matter deposition, where each factor influences the preferential hydrological pathways through that soil.

As well as hydrological impacts within the soils, vegetation provides surface roughness which influences overland flow velocity through friction. In many cases, once overland flow is produced, surface roughness is the primary control on 'slowing the flow' downslope where no other interventions are present. Hydrological models show the potential effectiveness of roughness over surface runoff. For example, empirical measurements by Holden et al. (2008) showed that overland flow velocity on bare peat was five times greater than through *Eriophorum sedge*, whereas velocity through *Sphagnum* moss was 50 % lower than through *Eriophorum*. Gao et al. (2015) used these values as surface roughness parameters within Spatially-Distributed TOPMODEL: bare peat produced a flood peak 46.3 % higher and 5 timesteps earlier than *Eriophorum*, and *Sphagnum* moss produced a flood peak 40.3 % lower and 6 timesteps later than *Eriophorum*. Although the land covers used were uniform across the whole catchment, the potential influence of surface roughness is clear.

However, there are few empirical measurements of hillslope-based roughness and fewer still in temperate upland environments. Where roughness is studied, it is most often in relation to soil erosion within which vegetation cover has been shown to reduce erosion and runoff (Zuazo and Pleguezuelo, 2009). However, relatively few studies disentangle the multiple hydrologic processes involved to focus on roughness (specifically, flow resistance (Smith, 2014)) impacts to downslope velocity alone. Where roughness alone has been measured, field-based research includes measurements of single-species vegetated slopes (Roels, 1984), silty clay loam soils (Gilley and Finkner, 1991), minimally vegetated desert environments (Abrahams and Parsons, 1991, Abrahams et al., 1986), varying grass species on the loess plateau in China (Li and Pan, 2018), and *Sphagnum* moss, *Eriophorum sedge* and bare peat (Holden et al., 2008). Laboratory-based studies include measurements of agricultural crop environments (Gilley and Kottwitz, 1995, Gilley and Kottwitz, 1994, Gilley et al., 1992), grass plots (unknown species) with leaf litter or stem-only (Pan et al., 2016), artificial horsehair 'vegetation' (Wu et al., 1999), and wheatgrass, represented in plastic

form (Shang et al., 2020). No studies investigated the seasonality of vegetation or the influence of management on surface roughness.

Because roughness measurements are so rare, many hydrological models rely on simplistic calculations of Manning's  $n$  or use Darcy Weisbach roughness to represent vegetation changes. However, there is debate about whether these types of measurement are appropriate for hillslope runoff and whether the data accurately represent land-use controls on flow (Augustijn et al., 2008, Smith et al., 2007a).

### 1.4.3 Land-use management within NFM

Since land use is often mosaiced with multiple uses, managers could consider how each of those land uses contributes to runoff as well as accounting for the practicalities and value related to those land uses (Richert et al., 2011). Often other factors, such as income, water quality, biodiversity and land access need to be considered in addition to NFM (Short et al., 2019, Spray et al., 2016). Sometimes, large changes may be made for which whole sections of the catchment experience change. Examples include complete removal of grazing (Marshall et al., 2014), wetland creation (Acreman and Holden, 2013), peat restoration (Allott et al., 2019, Shuttleworth et al., 2019) and woodland planting (Carrick et al., 2019). Other times, relatively small changes can be made such as the creation of buffer strips (Mason-McLean, 2020, Mclean et al., 2015), reducing compaction through lower grazing intensity or use of lighter machinery (Alaoui et al., 2018), cover crops or livestock rotations (Antolini et al., 2020, Kauffman and Krueger, 1984), soil aeration (Wallace and Chappell, 2019), and maintaining hedgerows within grassland (Wallace et al., 2021). Often, multiple management methods are employed based on suitability and needs within the catchment. For example, in the Isbourne catchment, UK, urbanisation at the valley bottom reduced flood plain size significantly, therefore multiple NFM interventions were recommended to store and slow flows including ponds, buffer strips, shelter belts, leaky timber walls and wetlands (Clarke and Short, 2017).

Alongside the practicalities of NFM, placement of NFM must also be considered. Modelling has shown that NFM is more effective in some locations than others; for example, Gao et al.

(2016) found that the riparian zone had three times more influence on runoff peaks than if the same changes were made in the catchment headwaters. Targeted interventions can also be made using NFM opportunity mapping, for which NFM is recommended based on catchment characteristics (Lavers and Charlesworth, 2018). NFM also has the potential to affect runoff synchronicity between catchments (Holden, 2005, Blanc et al., 2012, Ferguson and Fenner, 2020) which can be an effective flood mitigation tool, even at a large scale, if significant sub-catchment changes are made under careful consideration (Pattison et al., 2014); without such considerations, sub-catchments may be brought into synchronicity, increasing flood risk.

Another consideration is the intended scale of NFM. Land management has proven effective at reducing runoff at the plot and hillslope scales but there is little evidence available of its effectiveness at scales  $>20 \text{ km}^2$ , especially based on observed data (Dadson et al., 2017, Kay et al., 2019, Black et al., 2021). Where observations have been used, focus has often been on woodlands (Peskestt et al., 2021, Cooper et al., 2021) or in-stream NFM interventions (Nicholson et al., 2020, Quinn et al., 2013), as opposed to grassland environments (Ellis et al., 2021). Hydrological modelling can be used to scale-up NFM interventions based on hillslope analysis, however there is a dearth of empirical data which, for rainfall-runoff, is at a high enough frequency and duration for event-based modelling, and, for land use properties, is directly applicable to the model parameters (Wells et al., 2020). Grassland heterogeneity is rarely represented in hydrological modelling; instead, many models use just two Manning's  $n$  values representing 'short' or 'tall' grass (Ellis et al., 2021, Chow, 1959).

Finally, each form of land use change or management has different cost implications; NFM is generally less expensive than installing traditional 'hard-engineered' structures for flood management, however maintenance costs and durability also need to be considered (Aerts, 2018). Sometimes traditional methods alone, or in combination with NFM or Sustainable Urban Drainage (SuDs), are required to mitigate flood risk to the degree needed (Burgess-Gamble et al., 2017). Since many stakeholders may benefit from NFM, the largest considerations are often the cost, who will fund and maintain the interventions and how effective those interventions will be over time (Bark et al., 2021). To aid decision-making, cost-benefit analysis is often undertaken which includes hydrological modelling of the

intended NFM; within this, different types of management, land-use configuration, synchronicity and scale can all be altered.

## 1.5 Hydrological modelling

Hydrological models simulate catchment hydrological processes to predict water pathways through the system and the output river discharge. Models can be used to forecast events and test our understanding of catchment behaviour. Although models are always a simplification of real-world processes, they allow NFM to be tested under a range of storm events and land-use scenarios before implementation. 'Extreme' scenarios can also be tested to show the impact of rare, catastrophic events or alternative management schemes. The choice of model type is essential in appropriately testing the intended NFM where, often, upland initiatives are small-scale but highly distributed and alter a wide range of catchment processes (Hankin et al., 2017). The key characteristics of hydrological models are described below alongside associated, well-known models. The appropriateness of different models for hillslope runoff from OM soil-based grasslands is considered, with further detail on the model chosen, and why, given in section 1.7.2.

Hydrological models can be physically or empirically based, continuous or event based, and lumped, semi distributed or fully distributed. Each type and combination has its own set of advantages and nearly all include equations for evapotranspiration, unsaturated soil water movement, overland flow and groundwater flow (Forbes et al., 2015). Physical models represent the catchment processes as realistically as possible, whereas empirical models are equation-based and designed to fit the data. With so little known about OM soil hydrology (see section 1.3), inputting empirical data will help determine more realistic catchment-scale influences. Continuous models cover a long time period, including the catchment reaction between flooding events, whereas event-based models represent individual storm events. Although antecedent conditions play a key role in flood potential, NFM is primarily implemented for flood mitigation against individual storm events, an event-based approach is most appropriate.

Lumped models, such as IHACRES (Jakeman et al., 1990) and ReFH (Kjeldsen et al., 2005), are parametrically and computationally efficient, representing the entire catchment as one, usually averaging input values for the whole catchment. However, this approach removes spatial heterogeneity and therefore lumped models are not appropriate for modelling differences in land use within one catchment, as intended in this thesis. However lumped models do have some NFM applications, being frequently used for model calibration and to represent peak flow sensitivity and the catchment hydrograph reaction (Owen, 2016).

Semi-distributed models, such as SWAT (Arnold et al., 1998), HBV (Bergström, 1976, Bergström, 1992) and Dynamic TOPMODEL (Metcalf et al., 2015, Beven and Freer, 2001), have parameters which partially spatially vary, usually dividing the basin into a number of sub-basins with a single parameter for land use and soil characteristics. This approach allows for some level of heterogeneity to be implemented, whilst reducing the complexity of model so that model run time is reduced (Metcalf et al., 2018).

Distributed models, such as MIKE-SHE (DHI, 2022) and Spatially-Distributed TOPMODEL (SD-TOPMODEL; Gao et al. (2015)), are able to fully spatially distinguish between factors such as soil infiltration, surface roughness or rainfall across a catchment, and therefore are frequently used to quantify the impact of land use change (Lin et al., 2007). Catchment characteristics are applied on a cell-scale basis, with each cell producing its own hydrological response to model inputs. Often, distributed models can be used to identify NFM sensitive areas within a catchment. Hankin et al. (2017) recommend a tiered approach by which detailed distributed models are first employed to prioritise areas for potential development, followed by a semi-distributed model, in this case Dynamic TOPMODEL, for which uncertainty analysis can aid the decision-making process.

### 1.5.1 Model uncertainty

No model is an exact reflection of the complex interaction processes and heterogeneity naturally found in catchments, where even the most complex models are simplifications of reality (Beven, 2012, McDonnell et al., 2007). Frequently, there is insufficient empirical data to represent catchments, and even catchments which have seemingly similar characteristics



(i.e., same land use, geology, soil type etc.) can have very different hydrological response to rainfall (Beven, 2000). Where observed data are used (where many models require rainfall-runoff data for calibration and validation), there are often a large number of possible parameter sets which give similar fits to the observed data (Grayson et al., 2002). Fieldwork and telemetered catchments can increase data availability and provide some level of observed heterogeneity; however, they cannot overcome the dearth of data entirely. Therefore, assumptions and generalisations are always made in modelling because some hydrological processes involved are unknown, unobservable, occur over a large spatial or temporal scale, or are complex and therefore must be subject to simpler approximations (McDonnell et al., 2007). Fieldwork is also subject to instrumental uncertainty, reflecting a specific place in time, and therefore subject to scaling errors when used in modelling (Chappell and Lancaster, 2007).

Despite uncertainties, modelling is still a highly useful method for predicting runoff behaviour in response to storm events and runoff controls applied. Uncertainty can be measured through analytical methods such as GLUE (Beven and Binley, 2014) and limits of acceptability applied to observed and modelled data; however, most applications will necessarily involve some subjective choice which influences model probabilities (Beven, 2018). Ultimately, models should be chosen which best represent the catchment characteristics, including any management applied, and utilise the best available data (Beven et al., 2020); through this, model outcomes are as representative of catchment hydrological processes as possible.

## 1.6 Research questions

Using the above literature as guidance, three key topics were explored which aimed to further knowledge of upland OM soils hydrological systems with real-world recommendations for NFM. These topics were:

- 1. OM soil hydrology in upland grasslands**
- 2. Vegetative roughness and its influence on overland flow**
- 3. Spatially distributed NFM modelling using empirical data**

Focus was given to grassland environments, the most commonly occurring land use on OM soils. Grasslands have distinctive, but adaptable, management strategies which allow for realistic implementation of NFM if deemed to be effective. In addition, field-based investigations were designed in part to provide empirical data for entry into SD-TOPMODEL. Three research questions were identified:

- 1) **To what extent does land management affect OM soil properties and their associated hydrology?**
- 2) **To what extent does vegetation cover of upland OM soils influence surface roughness and its associated overland flow velocity?**
- 3) **How does management on upland OM soils influence downstream discharge peak magnitude and timing?**

## 1.7 Overview of the methodological approach

The following section provides an overview of the methodological approach for fieldwork and hydrological modelling in relation to the three research questions posed. Choices of fieldwork location and model chosen are justified, and methods outlined. A detailed methodology for fieldwork and modelling is included in subsequent relevant chapters which are introduced at the end of this chapter.

### 1.7.1 Fieldwork approach

One catchment was chosen as a basis for all fieldwork. Swindale (54°30'23"N, 002°45'47"W) is a 2.66 km<sup>2</sup> U-shaped valley in the Lake District, UK. Swindale has upland OM soils, primarily Malvern 611b and Bangor 311e, which are underlain by igneous shale and bedrock (Cranfield University, 2022). The U-shaped valley ranges between 270 m and 430 m elevation and has an average slope of  $7.4 \pm 5.8^\circ$ . The valley forms part of a wider 15.3 km<sup>2</sup> catchment which ranges between 430 m and 710 m elevation, has an average slope of  $6.9 \pm 5.3^\circ$ , and is covered by Winter Hill 1011b blanket bog. Swindale is owned by United Utilities and managed for livestock grazing by RSPB Haweswater under a higher level stewardship scheme; this pays land managers to use environmentally conscious practices such as

protecting water quality and carbon stocks, planting trees and maintaining wildflower meadows (Natural England, 2012).

Within Swindale, six grassland management types are found alongside each other. The range of grasslands makes Swindale an ideal location to study how management contributes to hydrological function while minimising other differences in external influences such as soil type, aspect, climate, weather, and geology. By studying one catchment, detailed monitoring could be undertaken with multiple repetitions of experiments, creating rich datasets and allowing an in-depth process-based investigation. Below, a brief overview of empirical measurements is provided, while full details are provided in subsequent chapters.

**Research question one: To what extent does land management affect OM soil properties and their associated hydrology?**

Intact soil cores were taken across the full range of habitat elevation. Laboratory analysis using an Eijkelkamp permeameter, oven drying and loss on ignition enable measurement of saturated hydraulic conductivity ( $K_s$ ,  $\text{m day}^{-1}$ ), bulk density ( $\text{g cm}^3$ ), and total organic matter (TOM, %).

In addition, a paired-plot method was used to compare habitats at equal elevation for two sites on the 'upper' and 'lower' hillslopes over the course of 10-months. Soil moisture (%) was measured at 5 cm, 10 cm and 15 cm depth every 15-minutes using Campbell 5TM sensors. Overland flow presence was recorded every 5-minutes using electrical resistance sensors. Finally, 15-minute interval rainfall and runoff data were obtained from local gauges.

**Research question two: To what extent does vegetation cover of upland OM soils influence surface roughness and its associated overland flow velocity?**

Seasonal measurements of overland flow velocity were recorded across five field campaigns using a novel hillslope flume. Tracer application enabled water velocities to be established for different slopes, water injection rates and vegetation conditions.

## 1.7.2 Modelling approach

Modelling was used to answer research question three: How does management on upland OM soils influence downstream discharge peak magnitude and timing? Modelling was used so that potential land management scenarios could be tested under a range of storm sizes without real-world implementation and associated time required to establish each management type. This approach also allowed the same storm event to be 'applied' to each management, thus allowing for direct comparison of runoff response.

The TOPMODEL approach is best suited to catchments with shallow soils and moderate topography which are dominated by shallow subsurface and overland flows and do not experience excessively dry periods (Devia et al., 2015). This makes TOPMODEL ideal for the upland grassland catchments studied in this thesis. However, a variant of TOPMODEL, SD-TOPMODEL was deemed most suitable as described below.

Two catchments were studied using SD-TOPMODEL. These were Swindale (see section 1.7.1), and Upper Calderdale, West Yorkshire, UK. Upper Calderdale is a heavily modified 20.9 km<sup>2</sup> catchment (Defra, 2021) which is basin-shaped with a relatively flat catchment top and bottom, and steep midslopes which average  $10.2 \pm 7.8^\circ$  and range between 124 m and 478 m elevation. Like Swindale, Calderdale has Winter Hill 1011b headwaters with OM soil slopes, consisting of Belmont 0651a and Wilcocks 0721c soils. It has multiple land cover types including acid grassland, blanket bog, woodland, heather-dominated scrub, grazed pasture and urban space.

Below, original TOPMODEL is briefly described outlining why it was not used in the thesis. This is followed by a description of SD-TOPMODEL, its applicability to the catchments modelled and its parameters. The description of SD-TOPMODEL provides context for some of the field measurements conducted in the thesis in that while they were used to answer research questions 1 and 2 in their own right, they also directly helped parameterise the model to answer research question 3.

## Original TOPMODEL

The original TOPMODEL was developed by Beven and Kirkby (1979) as a continuous lumped or semi-distributed deterministic hydrological model applicable to catchments dominated by shallow subsurface flow and overland flows (Gao et al., 2015). It is a conceptual model, however it is often described as being 'physically-based' because its parameters can be directly measured *in situ* (Franchini et al., 1996). Typically, TOPMODEL is event based and therefore operates over a 1 to 24 hour timescale. Since spatially variable surface runoff was hypothesised to be a critical component of OM soil hydrology, potentially controlling downstream flow peaks, original TOPMODEL was not ideal for use in this study.

## Spatially-distributed TOPMODEL

SD-TOPMODEL was developed by Gao et al. (2015) from the original TOPMODEL. It is a fully distributed model, calculating rainfall-runoff response using the same equations as Beven and Kirkby (1979), applying them per cell within the digital elevation model (DEM) and treating subsurface and overland flow as separate runoff responses. Critically, SD-TOPMODEL allows the user to vary surface landscape properties that influence overland flow velocity. Therefore, it is ideal for assessing the influence of land management on modelled flood risk.

According to Gao et al. (2016), SD-TOPMODEL has two key advantages and follows three strict assumptions:

### Advantages

- 1) *It can predict, during and after storm events, the locations of overland flow occurrence, the rates of overland flow production, the pathways of overland flow movement, and the locations where overland flow infiltrates into soil or enters river channels;*
- 2) *It represents the mechanism through which the velocity of overland flow is modified, according to the surface roughness presented by the vegetation cover, taking gradient and flow depth into account. These advantages mean that landcover change in different parts of the basin can be evaluated with regard to impacts on the flow at the basin outlet.*

## Assumptions

- 1) *The soil hydraulic conductivity decreases exponentially with increasing water deficit below saturation*
- 2) *Rainfall and runoff are spatially uniform in a cell*
- 3) *The Manning's equation is used as an expression of land surface resistance to overland flow*

## **Spatial structure of the model**

SD-TOPMODEL uses a computational grid. Instead of calculating flow using a topographic index of hydrological similarity, a DEM is used to calculate the individual hydrological behaviour within each catchment cell. Because the DEM cell system allows the catchment to be divided, catchment characteristics can be applied at the cell scale to represent land cover changes through three key parameters. The parameters which can be represented, and their derivation is described below.

## **Runoff production**

Key equations used to calculate runoff were kept, but downscaled, from the original TOPMODEL equations at a catchment scale to a cell scale (Gao et al., 2016). Using the cell scale, a new overland flow module, based upon multi-directional flow theory (Quinn et al., 1991), computes movement of runoff across and between individual cells. As overland flow is produced, it can be output either as overland flow or as subsurface flow after re-infiltration. For each cell, as overland flow 'arrives' into that cell, it is treated as input water to that cell and therefore may further produce overland flow or continue as subsurface flow. In addition to this, because the cell scale allows for spatial distribution, overland flow and subsurface flow can be calculated separately. Consequently, different delays can be shown on a stream hydrograph and related to land cover influences on that flow.

Within SD-TOPMODEL, time delays for overland flow are incorporated relating to surface gradient, flow depth and land surface cover, as represented by different parameters. Time delays are the result of acceleration or friction of runoff from cell to cell downslope, and also influence the likelihood of infiltration and subsurface flow between cells. This process directly reflects realistic hillslope-runoff reactions and is a mechanism rarely used in other hydrological models (Gao et al., 2015).

## Parameters

In this thesis, fieldwork outputs will be used directly to provide parameters within SD-TOPMODEL. SD-TOPMODEL has three primary parameters which can be input at the cell scale to represent the catchment:

- 1)  $K$ , the hydraulic conductivity of the soil;
- 2)  $m$ , a scaling factor which controls the decrease of transmissivity with depth and the shape of the hydrograph recession, representing active water storage within the soil;
- 3)  $K_v$ , an overland flow velocity parameter which is related to surface roughness.

As with TOPMODEL, SD-TOPMODEL has the advantage that it has few parameter inputs, and therefore is relatively simple to run, calibrate and validate. For further information about SD-TOPMODEL parameters and associated equations see Appendix C1.

## Summary of SD-TOPMODEL

Therefore, in order to run SD-TOPMODEL, the following data are required:

- *The hydraulic conductivity of the soil,  $K$*
- *The active water storage in the soil,  $m$  (scaling parameter)*
- *The overland flow velocity parameter, surface roughness,  $K_v$*
- *Interception percentage as function of rainfall (if used)*
- *Runoff (catchment specific discharge) time series*
- *Rainfall (metres) time series*
- *Evapotranspiration (metres) time series*
- *Digital elevation model for catchment*
- *Land cover data for catchment*

## 1.8 Organisation of the thesis

Using the outlined methodological approach, the research questions identified in section 1.6 are explored in the following chapters for which a brief overview is given below.

**Chapter Two: Upland grassland management influences organo-mineral soil properties and their hydrological function.** This chapter presents a paired plot study comparing grazed and ungrazed fields at two different elevations. Over the course of 10 months, high-frequency measurements of overland flow presence and soil moisture were measured to compare habitat response to storm events. Soil properties were also compared between habitats and conclusions drawn relating to land use management.  $K_s$ , as measured in field campaigns, can be used as a parameter within SD-TOPMODEL.

**Chapter Three: Seasonal vegetation and management influence overland flow velocity and roughness in upland grasslands.** This chapter presents a novel overland flow hillslope flume measuring seasonal surface runoff velocity for four different commonly occurring grassland habitats. Comparisons regarding the effectiveness of 'slowing the flow' between grassland habitats at different times of year was discussed. Velocity can be used as a proxy for vegetative roughness and used as a parameter within SD-TOPMODEL.

**Chapter Four: The influence of land management and season on flood mitigation in two UK upland catchments.** This chapter presents a series of scenarios modelling the influence of seasonality and land use management to flood mitigation. Empirical data collected from Swindale was used to model flood peak and timing in Swindale and in Calderdale, UK.

**Chapter Five: Synthesis and conclusions.** This chapter discusses the outcomes of Chapters two, three and four, relating key conclusions back to the overarching research questions and discussing future research opportunities.



## 1.9 References

- Abrahams, & Parsons. (1991). Resistance to overland flow on desert pavement and its implications for sediment transport modeling. *Water Resources Research*, 27(8), 1827-1836.
- Abrahams, A., Parsons, A., & Luk, S.-H. (1986). Resistance to overland flow on desert hillslopes. *Journal of Hydrology*, 88(3-4), 343-363.
- Acreman, M., & Holden, J. (2013). How Wetlands Affect Floods. *Wetlands*, 33(5), 773-786. doi:10.1007/s13157-013-0473-2
- Adler, P., Raff, D., & Lauenroth, W. (2001). The effect of grazing on the spatial heterogeneity of vegetation. *Oecologia*, 128(4), 465-479.
- Aerts, J. C. (2018). A review of cost estimates for flood adaptation. *Water*, 10(11), 1646.
- Alaoui, A., Rogger, M., Peth, S., & Blöschl, G. (2018). Does soil compaction increase floods? A review. *Journal of Hydrology*, 557, 631-642.
- Allott, T., Auñón, J., Dunn, C., Evans, M., Labadz, J., Lunt, P., . . . Pilkington, M. (2019). *Peatland catchments and natural flood management*. Report to the IUCN UK peatland programme's commission of inquiry on peatlands update. Manchester, UK: University of Manchester.
- Antolini, F., Tate, E., Dalzell, B., Young, N., Johnson, K., & Hawthorne, P. L. (2020). Flood risk reduction from agricultural best management practices. *JAWRA Journal of the American Water Resources Association*, 56(1), 161-179.
- Archer, N., Bonell, M., Coles, N., MacDonald, A., Auton, C., & Stevenson, R. (2013). Soil characteristics and landcover relationships on soil hydraulic conductivity at a hillslope scale: A view towards local flood management. *Journal of Hydrology*, 497, 208-222.
- Archer, N., Bonell, M., Coles, N., MacDonald, A., Stevenson, R., & Hallett, P. (2012). *The relationship of forest and improved grassland to soil water storage and its implication on Natural Flood Management in the Scottish Borders*. Paper presented at the BHS Eleventh National Symposium, Hydrology for a changing world, Dundee, Scotland.
- Arnold, J. G., Srinivasan, R., Muttiah, R. S., & Williams, J. R. (1998). Large area hydrologic modeling and assessment part I: model development 1. *Journal of the American Water Resources Association*, 34(1), 73-89.
- Augustijn, D. C., Huthoff, F., & Van Velzen, E. (2008). *Comparison of vegetation roughness descriptions*. Paper presented at the River Flow 2008: 4th International Conference on Fluvial Hydraulics, Izmir, Turkey.
- Avery, B. W. (1980). *Soil classification for England and Wales (higher categories)*. Soil Survey Technical Monograph No. 14. Harpenden.
- Avery, B. W. (1990). *Soils of the British Isles*. Wallingford: CAB International.
- Bark, R. H., Martin-Ortega, J., & Waylen, K. A. (2021). Stakeholders' views on natural flood management: Implications for the nature-based solutions paradigm shift? *Environmental Science & Policy*, 115, 91-98.
- Bergström, S. (1976). *Development and application of a conceptual runoff model for Scandinavian catchments*. Report RH07. Norrköping, Sweden: SMHI.
- Bergström, S. (1992). *The HBV model—its structure and applications*. Norrköping, Sweden: SMHI.

- Beven, K., Asadullah, A., Bates, P., Blyth, E., Chappell, N., Child, S., . . . Fowler, H. J. (2020). Developing observational methods to drive future hydrological science: Can we make a start as a community? *Hydrological Processes*, 34(3), 868-873.
- Beven, K., & Binley, A. (2014). GLUE: 20 years on. *Hydrological Processes*, 28(24), 5897-5918.
- Beven, K., & Freer, J. (2001). A dynamic topmodel. *Hydrological Processes*, 15(10), 1993-2011.
- Beven, K., & Kirkby, M. (1979). A physically based, variable contributing area model of basin hydrology/Un modèle à base physique de zone d'appel variable de l'hydrologie du bassin versant. *Hydrological Sciences Journal*, 24(1), 43-69.
- Beven, K. J. (2000). Uniqueness of place and process representations in hydrological modelling. *Hydrology and Earth System Sciences*, 4(2), 203-213.
- Beven, K. J. (2012). *Rainfall-runoff modelling: the primer. Second edition*. Chichester, UK: John Wiley & Sons.
- Beven, K. J. (2018). On hypothesis testing in hydrology: Why falsification of models is still a really good idea. *Wiley Interdisciplinary Reviews: Water*, 5(3), e1278.
- Black, A., Peskett, L., MacDonald, A., Young, A., Spray, C., Ball, T., . . . Werritty, A. (2021). Natural flood management, lag time and catchment scale: Results from an empirical nested catchment study. *Journal of Flood Risk Management*, e12717.
- Blanc, J., Wright, G., & Arthur, S. (2012). Natural Flood Management knowledge system: Part 2 – The effect of NFM features on the desynchronising of flood peaks at a catchment scale. *CREW report*. Edinburgh: Centre of Expertise for Waters.
- Bol, R., Blackwell, M., Emmett, B., Reynolds, B., Hall, J., Bhogal, A., & Ritz, K. (2011). *Assessment of the response of organo-mineral soils to change in management practices*. Sub-Project ii of Defra Project SP1106: Soil carbon: studies to explore greenhouse gas emissions and mitigation. DEFRA
- Bradley, R., Milne, R., Bell, J., Lilly, A., Jordan, C., & Higgins, A. (2005). A soil carbon and land use database for the United Kingdom. *Soil Use and Management*, 21(4), 363-369.
- Bruneau, P. M. C., & Johnson, S. M. (2014). *Scotland's peatland - definitions & information resources*. Scottish Natural Heritage Commissioned Report No 701. Edinburgh: Scottish Natural Heritage.
- Burgess-Gamble, L., Ngai, R., Wilkinson, M., Nisbet, T., Pontee, N., Harvey, R., . . . Quinn, P. (2017). *Working with natural processes to reduce flood risk*. Bristol, UK: Environment Agency.
- Burt, T., & Holden, J. (2010). Changing temperature and rainfall gradients in the British Uplands. *Climate Research*, 45, 57-70.
- Carrick, J., Abdul Rahim, M. S. A. B., Adjei, C., Ashraa Kalee, H. H. H., Banks, S. J., Bolam, F. C., . . . Domingos, I. F. N. (2019). Is planting trees the solution to reducing flood risks? *Journal of Flood Risk Management*, 12(S2), e12484.
- Chan, F. K. S., Griffiths, J. A., Higgitt, D., Xu, S., Zhu, F., Tang, Y.-T., . . . Thorne, C. R. (2018). "Sponge City" in China—A breakthrough of planning and flood risk management in the urban context. *Land Use Policy*, 76, 772-778.
- Chandler, K., Stevens, C., Binley, A., & Keith, A. (2018). Influence of tree species and forest land use on soil hydraulic conductivity and implications for surface runoff generation. *Geoderma*, 310, 120-127.
- Chappell, N. A., & Lancaster, J. W. (2007). Comparison of methodological uncertainties within permeability measurements. *Hydrological Processes*, 21(18), 2504-2514.
- Chow, V. T. (1959). Open-channel hydraulics. In *Open-channel hydraulics*. McGraw-Hill.

- Clarke, L. E., & Short, C. (2017). *Isbourne Catchment Community Report: Potential for Natural Flood Management in the Catchment (Final)*. Report to the Isbourne Catchment Group. Retrieved from Gloucestershire, UK:
- Clarke, M., Creamer, R., Deeks, L., Gowing, D., Holman, I., Jones, R., . . . Ritz, K. (2008). *Scoping study to assess soil compaction affecting upland and lowland grassland in England and Wales*. Final project (BD2304) report to Defra. London: DEFRA.
- Convention on Biological Diversity. (2010). *Decision X/2: Strategic Plan for Biodiversity 2011-2020, including Aichi Biodiversity Targets*. Paper presented at the Conference of the Parties Nagoya, Aichi Prefecture, Japan.
- Cooper, M. M., Patil, S. D., Nisbet, T. R., Thomas, H., Smith, A. R., & McDonald, M. A. (2021). Role of forested land for natural flood management in the UK: A review. *Wiley Interdisciplinary Reviews: Water*, e1541.
- Cranfield University. (2018). Soil Classification System for England and Wales. Available at: <http://www.landis.org.uk/downloads/classification.cfm> [Accessed 09/02/2018]
- Cranfield University. (2022). The Soils Guide [online]. Available at: [www.landis.org.uk](http://www.landis.org.uk) [Accessed 27/01/2022]
- CRED, & UNDRR. (2020). *Human cost of disasters: an overview of the last 20 years 2000-2019, 2020*. Centre for research on the epidemiology of disasters (CRED) & UN office for disaster risk reduction (UNDRR). Available at: <https://reliefweb.int/report/world/human-cost-disasters-overview-last-20-years-2000-2019>. [Accessed 21/01/2022]
- Dadson, S. J., Hall, J. W., Murgatroyd, A., Acreman, M., Bates, P., Beven, K., . . . Lane, S. N. (2017). A restatement of the natural science evidence concerning catchment-based 'natural' flood management in the UK. *Proceedings of the Royal Society A: Mathematical, Physical and Engineering Sciences*, 473(2199), 20160706.
- Defra. (2009). *Appraisal of flood and coastal erosion risk management. A Defra policy statement*. London: DEFRA.
- Defra. (2012). *The Government's Response to Sir Michael Pitt's Review of the Summer 2007 Floods. Final Progress Report*. London: DEFRA.
- Defra. (2016). *Key results by UK country: 1866 to 2016 [online]*. London: DEFRA. Available at: <https://www.gov.uk/government/statistical-data-sets/structure-of-the-agricultural-industry-in-england-and-the-uk-at-june>. [Accessed 25/01/2022]
- Defra. (2021). Calder from Source to Walsden Water Water Body. Available at: <https://environment.data.gov.uk/catchment-planning/WaterBody/GB104027062660>. [Accessed 25/01/2022]
- Defra, & Coffey, T. (2017). Schemes across the country to receive £15 million of natural flood management funding [Press release] Available: <https://www.gov.uk/government/news/schemes-across-the-country-to-receive-15-million-of-natural-flood-management-funding> [Accessed 16/03/2022]
- Defra, & Environment Agency. (2011). *The national flood and coastal erosion risk management strategy for England*. Bristol: Environment Agency.
- Devia, G. K., Ganasri, B., & Dwarakish, G. (2015). A review on hydrological models. *Aquatic Procedia*, 4, 1001-1007.
- DHI. (2022). MIKE SHE User Guide and Reference Manual. Available at: [https://manuals.mikepoweredbydhi.help/latest/MIKE\\_SHE.htm](https://manuals.mikepoweredbydhi.help/latest/MIKE_SHE.htm). [Accessed 16/02/2022].

- Drewry, J. (2006). Natural recovery of soil physical properties from treading damage of pastoral soils in New Zealand and Australia: a review. *Agriculture, Ecosystems & Environment*, 114(2-4), 159-169.
- Ellis, N., Brazier, R., & Anderson, K. (2021). Comparing fine-scale structural and hydrologic connectivity within unimproved and improved grassland. *Ecohydrology*, 14(7), e2330.
- Environment Agency. (2010). *Flood and coastal erosion risk management appraisal guidance*. Bristol: Environment Agency.
- Environment Agency. (2018). *Estimating the economic costs of the 2015 to 2016 winter floods*. Bristol: Environment Agency.
- Environment Agency, & cbec. (2017). *Natural flood management toolbox, Guidance for working with natural processes in flood management schemes*. Inverness, UK: cbec eco-engineering.
- Ferguson, C., & Fenner, R. (2020). Evaluating the effectiveness of catchment-scale approaches in mitigating urban surface water flooding. *Philosophical Transactions of the Royal Society A*, 378(2168), 20190203.
- Forbes, H., Ball, K., & McLay, F. (2015). *Natural Flood Management Handbook*. Stirling, UK: SEPA.
- Franchini, M., Wendling, J., Obled, C., & Todini, E. (1996). Physical interpretation and sensitivity analysis of the TOPMODEL. *Journal of Hydrology*, 175(1-4), 293-338.
- Freeman, C. G. (2020). *Upland flood mitigation by managing infiltration*. (PhD Thesis), Aberystwyth University.
- Gao, J., Holden, J., & Kirkby, M. (2015). A distributed TOPMODEL for modelling impacts of land-cover change on river flow in upland peatland catchments. *Hydrological Processes*, 29(13), 2867-2879.
- Gao, J., Holden, J., & Kirkby, M. (2016). The impact of land-cover change on flood peaks in peatland basins. *Water Resources Research*, 52(5), 3477-3492.
- Gifford, G. F., & Hawkins, R. H. (1978). Hydrologic impact of grazing on infiltration: a critical review. *Water Resources Research*, 14(2), 305-313.
- Gilley, J. E., & Finkner, S. C. (1991). Hydraulic roughness coefficients as affected by random roughness. *Biological Systems Engineering: Papers and Publications*, 122.
- Gilley, J. E., & Kottwitz, E. (1994). Darcy-Weisbach roughness coefficients for selected crops. *Transactions of the ASAE*, 37(2), 467-471.
- Gilley, J. E., & Kottwitz, E. R. (1995). Darcy-Weisbach roughness coefficients for surfaces with residue and gravel cover. *Transactions of the ASAE*, 38(2), 539-544.
- Gilley, J. E., Kottwitz, E. R., & Wieman, G. (1992). Darcy-Weisbach roughness coefficients for gravel and cobble surfaces. *Journal of Irrigation and Drainage Engineering*, 118(1), 104-112.
- Gowing, D., Lawson, C., Youngs, E., Barber, K., Rodwell, J., Prosser, M., . . . Spoor, G. (2002). *The water regime requirements and the response to hydrological change of grassland plant communities*. DEFRA-commissioned project BD1310. Institute of Water and Environment, Bedford, UK: Cranfield University.
- Grant, L. (2011). *Integrated water management*. CIWEM briefing report. London: The Chartered Institution of Water and Environmental Management.
- Grayson, R. B., Blöschl, G., Western, A. W., & McMahon, T. A. (2002). Advances in the use of observed spatial patterns of catchment hydrological response. *Advances in Water Resources*, 25(8-12), 1313-1334.

- Hankin, B., Metcalfe, P., Johnson, D., Chappell, N. A., Page, T., Craigen, I., . . . Beven, K. (2017). Strategies for testing the impact of natural flood risk management measures. In T. Hromadka (Ed.), *Flood risk management* (pp. 1-39). Rijeka: IntechOpen
- Hirabayashi, Y., Mahendran, R., Koirala, S., Konoshima, L., Yamazaki, D., Watanabe, S., . . . Kanae, S. (2013). Global flood risk under climate change. *Nature Climate Change*, 3(9), 816-821.
- Hirabayashi, Y., Tanoue, M., Sasaki, O., Zhou, X., & Yamazaki, D. (2021). Global exposure to flooding from the new CMIP6 climate model projections. *Scientific Reports*, 11(1), 1-7.
- Hodgson, J. M. (1997). *Soil Survey Field Handbook*. Soil Survey Technical Monograph No. 5. Harpenden, UK: Rothamsted Experimental Station.
- Holden, J. (2005). Peatland hydrology and carbon release: why small-scale process matters. *Philosophical Transactions of the Royal Society of London A: Mathematical, Physical and Engineering Sciences*, 363(1837), 2891-2913.
- Holden, J., & Burt, T. P. (2003). Runoff production in blanket peat covered catchments. *Water Resources Research*, 39(7).
- Holden, J., Chapman, P., Evans, M., Hubacek, K., Kay, P., & Warburton, J. (2007). *Vulnerability of organic soils in England and Wales*. Final technical report to DEFRA and Countryside Council for Wales. DEFRA Project SP0532. London: DEFRA.
- Holden, J., Kirkby, M. J., Lane, S. N., Milledge, D. G., Brookes, C. J., Holden, V., & McDonald, A. T. (2008). Overland flow velocity and roughness properties in peatlands. *Water Resources Research*, 44(6).
- Hudson, B. D. (1994). Soil organic matter and available water capacity. *Journal of Soil and Water Conservation*, 49(2), 189-194.
- IPCC. (2013). *Summary for Policymakers*. In: Stocker, T.F., Qin, D., Plattner, G-K., Tignor, M., Allen, S.K., Boschung, J., . . . Midgley, P.M. (eds.) *Climate Change 2013: The Physical Science Basis. Contribution of Working Group I to the Fifth Assessment Report of the Intergovernmental Panel on Climate Change*. Cambridge, United Kingdom and New York, NY, USA: Cambridge University press.
- IUSS Working Group WRB. (2014). *World Reference Base for Soil Resources, update 2015 International soil classification system for naming soils and creating legends for soil maps*. In: FAO (ed.) *World Soil Resources Reports No. 106*. Rome: FAO.
- Jakeman, A., Littlewood, I., & Whitehead, P. (1990). Computation of the instantaneous unit hydrograph and identifiable component flows with application to two small upland catchments. *Journal of Hydrology*, 117(1-4), 275-300.
- Jarvis, R., Bendelow, V., Bradley, R., Carroll, D., Furness, R., Kilgour, I., & King, S. (1984). *Soils and their use in northern England*. Harpenden, UK: Rothamsted Experimental Station.
- Joint Nature Conservation Committee. (2011). *Towards an assessment of the state of UK Peatlands. JNCC report 445. ISSN 0963 8901*. Available at: <http://jncc.defra.gov.uk/page-5861> [Accessed 15/12/2021]
- Juárez, A., Alfredsen, K., Stickler, M., Adeva-Bustos, A., Suárez, R., Seguín-García, S., & Hansen, B. (2021). A Conflict between Traditional Flood Measures and Maintaining River Ecosystems? A Case Study Based upon the River Lærdal, Norway. *Water*, 13(14), 1884.

- Kauffman, J. B., & Krueger, W. C. (1984). Livestock impacts on riparian ecosystems and streamside management implications... a review. *Rangeland Ecology & Management/Journal of Range Management Archives*, 37(5), 430-438.
- Kay, A., Old, G., Bell, V., Davies, H., & Trill, E. (2019). An assessment of the potential for natural flood management to offset climate change impacts. *Environmental Research Letters*, 14(4), 044017.
- Kjeldsen, T., Stewart, E., Packman, J., Folwell, S., & Bayliss, A. (2005). *Revitalisation of the FSR/FEH rainfall-runoff method*. CEH, Wallingford.
- Klaar, M. J., Carver, S., & Kay, P. (2020). Land management in a post-Brexit UK: An opportunity for integrated catchment management to deliver multiple benefits? *Wiley Interdisciplinary Reviews: Water*, 7(5), e1479.
- Lane, S. N. (2017). Natural flood management. *Wiley Interdisciplinary Reviews: Water*, 4(3) e1211.
- Lane, S. N., Morris, J., O'Connell, P. E., & Quinn, P. F. (2007). Managing the rural landscape. In Colin R. Thorne, E. P. Evans, & E. C. Penning-Rowsell (Eds.), *Future flooding and coastal erosion risks* (pp. 297 - 319). London: Thomas Telford.
- Lavers, T., & Charlesworth, S. (2018). Opportunity mapping of natural flood management measures: a case study from the headwaters of the Warwickshire-Avon. *Environmental Science and Pollution Research*, 25(20), 19313-19322.
- Li, C., & Pan, C. (2018). The relative importance of different grass components in controlling runoff and erosion on a hillslope under simulated rainfall. *Journal of Hydrology*, 558, 90-103.
- Lilly, A., Grieve, I. C., Jordan, C., Baggaley, N. J., Birnie, R. V., Futter, M. N., . . . Towers, W. (2009). *Climate change, land management and erosion in the organic and organo-mineral soils in Scotland and Northern Ireland*. Scottish Natural Heritage Commissioned Report No.325 (ROAME No. F06AC104 - SNIFFER UKCC21). Edinburgh: Scottish Natural Heritage.
- Lin, Y.-P., Hong, N.-M., Wu, P.-J., Wu, C.-F., & Verburg, P. H. (2007). Impacts of land use change scenarios on hydrology and land use patterns in the Wu-Tu watershed in Northern Taiwan. *Landscape and Urban Planning*, 80(1-2), 111-126.
- Lowe, J. A., Bernie, D., Bett, P., Bricheno, L., Brown, S., Calvert, D., . . . Fosser, G. (2018). *UKCP18 science overview report*. Met Office Hadley Centre: Exeter, UK.
- Mackney, D., Hodgson, J., Hollis, J., & Staines, S. (1983). *Legend for the 1: 250,000 soil map of England and Wales*. Harpenden, UK: Soil Survey of England and Wales.
- Madani, E. M., Jansson, P. E., & Babelon, I. (2018). Differences in water balance between grassland and forest watersheds using long-term data, derived using the CoupModel. *Hydrology Research*, 49(1), 72-89.
- Marrs, R. H., Lee, H., Blackbird, S., Connor, L., Girdwood, S. E., O'Connor, M., . . . Chiverrell, R. C. (2020). Release from sheep-grazing appears to put some heart back into upland vegetation: A comparison of nutritional properties of plant species in long-term grazing experiments. *Annals of Applied Biology*, 177(1), 152-162.
- Marrs, R. H., Sánchez, R., Connor, L., Blackbird, S., Rasal, J., & Rose, R. (2018). Effects of removing sheep grazing on soil chemistry, plant nutrition and forage digestibility: Lessons for rewilding the British uplands. *Annals of Applied Biology*, 173(3), 294-301.
- Marshall, M., Ballard, C., Frogbrook, Z., Solloway, I., McIntyre, N., Reynolds, B., & Wheeler, H. (2014). The impact of rural land management changes on soil hydraulic properties

- and runoff processes: results from experimental plots in upland UK. *Hydrological Processes*, 28(4), 2617-2629.
- Marshall, M. R., Francis, O. J., Frogbrook, Z. L., Jackson, B. M., McIntyre, N., Reynolds, B., . . . Chell, J. (2009). The impact of upland land management on flooding: results from an improved pasture hillslope. *Hydrological Processes*, 23(3), 464-475.
- Mason-McLean, L. (2020). *Riparian buffer strips and their effectiveness as a natural flood management measure*. (PhD Thesis), Heriot-Watt University.
- McDonnell, J., Sivapalan, M., Vaché, K., Dunn, S., Grant, G., Haggerty, R., . . . Roderick, M. (2007). Moving beyond heterogeneity and process complexity: A new vision for watershed hydrology. *Water Resources Research*, 43(7).
- McIntyre, N., & Thorne, C. (2013). *Land use management effects on flood flows and sediments—guidance on prediction*. London: CIRIA.
- McLean, L., Beevers, L., Wilkinson, M., Starrs, G., & Pender, G. (2015). *Riparian buffer hydrology: representing catchment-wide implementation and the influence on flood risk*. Paper presented at the E-proceedings of the 36th IAHR World congress: 28 June–3 July, 2015, The Hague, Netherlands.
- Metcalfe, P., Beven, K., & Freer, J. (2015). Dynamic TOPMODEL: A new implementation in R and its sensitivity to time and space steps. *Environmental Modelling & Software*, 72, 155-172.
- Metcalfe, P., Beven, K., Hankin, B., & Lamb, R. (2018). A new method, with application, for analysis of the impacts on flood risk of widely distributed enhanced hillslope storage. *Hydrology and Earth System Sciences*, 22(4), 2589-2605.
- Meyles, E., Williams, A., Ternan, J., Anderson, J., & Dowd, J. (2006). The influence of grazing on vegetation, soil properties and stream discharge in a small Dartmoor catchment, southwest England, UK. *Earth Surface Processes and Landforms*, 31(5), 622-631.
- Monger, F., Spracklen, D., Kirkby, M., & Schofield, L. (2022). The impact of semi-natural broadleaf woodland and pasture on soil properties and flood discharge. *Hydrological Processes*, e14453.
- Murphy, T. R., Hanley, M. E., Ellis, J. S., & Lunt, P. H. (2020). Native woodland establishment improves soil hydrological functioning in UK upland pastoral catchments. *Degradation & Development*, 32(2), 1034-1045.
- National Audit Office. (2020). *Managing flood risk*. HC 962. Available at: <https://www.nao.org.uk/report/managing-flood-risk/>: [Accessed 15/02/2022]
- Natural England. (2012). *Higher Level Stewardship. Environmental Stewardship Handbook. Fourth edition - January 2013*. UK: Natural England.
- Nicholson, A. R., O'Donnell, G. M., Wilkinson, M. E., & Quinn, P. F. (2020). The potential of runoff attenuation features as a Natural Flood Management approach. *Journal of Flood Risk Management*, 13, e12565.
- Olorunfemi, I. E., Ogunrinde, T. A., & Fasinmirin, J. T. (2014). Soil hydrophobicity: An overview. *Journal of Scientific Research & Reports*, 3(8), 1003-1037.
- Owen, G. J. (2016). *Potential for natural flood management and land management practices to mitigate flooding in upland catchments*. (PhD Thesis), Newcastle University.
- Palmer, S., Holden, J., Baird, A., Chapman, P., Kirkby, M., Slack, R., . . . Ineson, P. (2014). *Beyond the bog: what we really know about hydrology, water quality and carbon storage in upland soils*. Paper presented at the Away from the blanket bog: the hydrology of upland non-peat soils, University of Leeds.

- Pan, C., Ma, L., Wainwright, J., & Shangguan, Z. (2016). Overland flow resistances on varying slope gradients and partitioning on grassed slopes under simulated rainfall. *Water Resources Research*, 52(4), 2490-2512.
- Pattison, I., Lane, S. N., Hardy, R. J., & Reaney, S. M. (2014). The role of tributary relative timing and sequencing in controlling large floods. *Water Resources Research*, 50(7), 5444-5458.
- Peel, M. C. (2009). Hydrology: catchment vegetation and runoff. *Progress in Physical Geography*, 33(6), 837-844.
- Peskett, L. M., Heal, K. V., MacDonald, A. M., Black, A. R., & McDonnell, J. J. (2021). Tracers reveal limited influence of plantation forests on surface runoff in a UK natural flood management catchment. *Journal of Hydrology: Regional Studies*, 36, 100834.
- Pitt, M. (2008). *The Pitt Review: Learning lessons from the 2007 floods*. London: Cabinet Office.
- Quinn, P., Beven, K., Chevallier, P., & Planchon, O. (1991). The prediction of hillslope flow paths for distributed hydrological modelling using digital terrain models. *Hydrological Processes*, 5(1), 59-79.
- Quinn, P., O'Donnell, G., Nicholson, A., Wilkinson, M., Owen, G., Jonczyk, J., . . . Davies, G. (2013). *Potential use of runoff attenuation features in small rural catchments for flood mitigation*. NFM RAF Report. Newcastle upon Tyne, Newcastle: Newcastle University.
- Reicosky, D. (2005). *Alternatives to mitigate the greenhouse effect: emission control by carbon sequestration*. Paper presented at the Proceedings of Plantio Direto E Meio Ambiente: Sequestro de Carbono E Qualidade da Agua, May 18-20, 2005, Foz do Iguacu, Brazil.
- Reid, C., Hornigold, K., McHenry, E., Nichols, C., Townsend, M., Lewthwaite, K., . . . Hugi, M. (2021). *State of the UK's Woods and Trees 2021*. Woodland Trust report. Available at: <https://www.woodlandtrust.org.uk/state-of-uk-woods-and-trees/> [Accessed 16/03/2022]
- Revell, N., Lashford, C., Blackett, M., & Rubinato, M. (2021). Modelling the Hydrological Effects of Woodland Planting on Infiltration and Peak Discharge Using HEC-HMS. *Water*, 13(21), 3039.
- Reynolds, B. (2007). Implications of changing from grazed or semi-natural vegetation to forestry for carbon stores and fluxes in upland organo-mineral soils in the UK. *Hydrology and Earth System Sciences*, 11(1), 61-76.
- Richert, E., Bianchin, S., Heilmeier, H., Merta, M., & Seidler, C. (2011). A method for linking results from an evaluation of land use scenarios from the viewpoint of flood prevention and nature conservation. *Landscape and Urban Planning*, 103(2), 118-128.
- Roels, J. (1984). Flow resistance in concentrated overland flow on rough slope surfaces. *Earth Surface Processes and Landforms*, 9(6), 541-551.
- Rogger, M., Agnoletti, M., Alaoui, A., Bathurst, J., Bodner, G., Borga, M., . . . Hall, J. (2017). Land-use change impacts on floods at the catchment scale—Challenges and opportunities for future research. *Water Resources Research*, 53(7), 5209-5219.
- Roovers, P., Baeten, S., & Hermy, M. (2004). Plant species variation across path ecotones in a variety of common vegetation types. *Plant Ecology*, 170(1), 107-119.
- Sansom, A. (1999). Upland vegetation management: the impacts of overstocking. *Water Science and Technology*, 39(12), 85-92.



- Scotland's Soils. (2017). Scottish Soil Classification [Excel database]. Available at: <http://soils.environment.gov.scot/resources/guide-to-soil-types/> [Accessed 09/02/2018]
- Scottish Environmental Protection Agency. (2015). *Natural Flood Management Handbook*. Stirling: Scottish Environmental Protection Agency.
- Scottish Government. (2010, 17/11/2010). Natural Flood Management Group. Available at: <http://www.gov.scot/Topics/Environment/Water/Flooding/FRMAct/saif/NFMG>: Scottish Government. [Accessed 11/04/2018]
- Shang, H., Zhang, K., Wang, Z., Yang, J., He, M., Pan, X., & Fang, C. (2020). Effect of varying wheatgrass density on resistance to overland flow. *Journal of Hydrology*, *591*, 125594.
- Short, C., Clarke, L., Carnelli, F., Uttley, C., & Smith, B. (2019). Capturing the multiple benefits associated with nature-based solutions: Lessons from a natural flood management project in the Cotswolds, UK. *Land Degradation & Development*, *30*(3), 241-252.
- Shuttleworth, E. L., Evans, M. G., Pilkington, M., Spencer, T., Walker, J., Milledge, D., & Allott, T. E. (2019). Restoration of blanket peat moorland delays stormflow from hillslopes and reduces peak discharge. *Journal of Hydrology X*, *2*, 100006.
- Smith, M. W. (2014). Roughness in the earth sciences. *Earth-Science Reviews*, *136*, 202-225.
- Smith, M. W., Cox, N. J., & Bracken, L. J. (2007). Applying flow resistance equations to overland flows. *Progress in Physical Geography*, *31*(4), 363-387.
- Smith, P., Smith, J., Flynn, H., Killham, K., Rangel-Castro, I., Foereid, B., . . . Bell, J. (2007). *ECOSSE: Estimating carbon in organic soils-sequestration and emissions* (0755914988). Scottish Executive Environment and Rural Affairs Department: Edinburgh.
- Soulsby, C. (1993). Contrasting hydrological regimes in two ploughed forest soils in upland Wales. *Forestry: An International Journal of Forest Research*, *66*(2), 153-170.
- Spray, C., Arthur, S., Bergmann, E., Bell, J., Beevers, L., & Blanc, J. (2016). *Land management for increased flood resilience*. Centre of Expertise for Waters (CREW) Facilitation Team: James Hutton Institute.
- Thomas, H., & Nisbet, T. (2007). An assessment of the impact of floodplain woodland on flood flows. *Water and Environment Journal*, *21*(2), 114-126.
- Van der Wal, R., Bonn, A., Monteith, D., Reed, M., Blackstock, K., Hanley, N., . . . Tinch, D. (2011). *Mountains, moorlands and heaths*. UK National Ecosystem Assessment: Technical Report. Cambridge: UNEP-WCMC.
- Wallace, E., & Chappell, N. (2019). Blade Aeration Effects on Near-surface Permeability and Overland-flow Likelihood on Two Stagnosol Pastures in Cumbria, UK. *Journal of Environmental Quality*, *48*(6), 1766-1774.
- Wallace, E. E., McShane, G., Tych, W., Kretzschmar, A., McCann, T., & Chappell, N. A. (2021). The effect of hedgerow wild-margins on topsoil hydraulic properties, and overland-flow incidence, magnitude and water-quality. *Hydrological Processes*, *35*(3), e14098.
- Wells, J., Labadz, J. C., Smith, A., & Islam, M. M. (2020). Barriers to the uptake and implementation of natural flood management: A social-ecological analysis. *Journal of Flood Risk Management*, *13*, e12561.
- Welsh Government. (2014, 15/09/2014). National Strategy for Flood and Coastal Erosion Risk Management. Available at:

- <http://gov.wales/topics/environmentcountryside/epq/flooding/nationalstrategy/strategy/?lang=en>. [Accessed 11/04/2018]
- West, V. (2011). *Soil Carbon and the Woodland Carbon Code*. Woodland Carbon Code. Available at: <https://www.woodlandcarboncode.org.uk/standard-and-guidance/1-eligibility/1-2-eligible-activities#whatareorganic>: [Accessed 16/02/2022]
- WG POM. (2014). *EU policy document on Natural Water Retention Measures*. Technical Report-2014-082. Prepared by the drafting team of the Water Framework Directive Common Implementation Strategy Working Group Programme of measures (WG PoM). Luxembourg: Office for Official Publications of the European Communities.
- Winsemius, H. C., Aerts, J. C., Van Beek, L. P., Bierkens, M. F., Bouwman, A., Jongman, B., . . . Van Vuuren, D. P. (2016). Global drivers of future river flood risk. *Nature Climate Change*, 6(4), 381-385.
- Wood, S., Sebastian, K., & Scherr, S. J. (2000). *Agroecosystems*. Pilot analysis of global ecosystems. Washington, DC, USA: International Food Policy Research Institute and World Resources Institute.
- Wright, A. J., Kroon, H., Visser, E. J., Buchmann, T., Ebeling, A., Eisenhauer, N., . . . Roscher, C. (2017). Plants are less negatively affected by flooding when growing in species-rich plant communities. *New Phytologist*, 213(2), 645-656.
- Wu, F.-C., Shen, H. W., & Chou, Y.-J. (1999). Variation of roughness coefficients for unsubmerged and submerged vegetation. *Journal of Hydraulic Engineering*, 125(9), 934-942.
- Zuazo, V. H. D., & Pleguezuelo, C. R. R. (2009). Soil-erosion and runoff prevention by plant covers: a review. In: N. M. Lichtfouse E., Debaeke P., Véronique S., Alberola C. (ed.), *Sustainable agriculture* (pp. 785-811). Springer: Dordrecht.

## Chapter 2. Upland grassland management influences organo-mineral soil properties and their hydrological function

<sup>1</sup>Bond, S., <sup>1</sup>Kirkby, M.J. and <sup>1</sup>Holden, J.

<sup>1</sup>water@leeds, School of Geography, University of Leeds, Leeds, LS2 9JT, UK.

### 2.1 Abstract

Land-use change acts as a potential moderator of flood risk, affecting vegetation and soil properties, and thus influencing the storage and flow of water across landscapes. This study, conducted in northwest England, investigated physical soil properties and their hydrological function using overland flow and soil moisture sensors, for five upland grassland habitats each created through management action. Overland flow was common, occurring up to 60 % of the time with longer durations in grassland excluded from grazing with higher density vegetation. Soil moisture varied significantly between grassland habitats, but there was no clear soil moisture threshold for overland flow. Surface soil properties to 5 cm depth varied significantly between grassland types, with saturated hydraulic conductivity ( $K_s$ ) ranging across several orders of magnitude from  $1.3 \times 10^{-3}$  to  $1.5 \times 10^2$  m day<sup>-1</sup>. With shallow soils and a median  $K_s$  of 2.4 m day<sup>-1</sup>, saturation-excess overland flow was determined as the main driver of flood risk. Landscape management was found to be a significant driver of soil physical and hydrological properties in upland grasslands, and therefore should be strongly considered as part of flood management.

### 2.2 Introduction

As the occurrence of extreme weather events such as droughts and floods increase, landscape management is being considered to enhance resilience (Forbes et al., 2015). Land-cover is thought to be a key moderator for flood and drought risk by affecting the storage and transfer of water across landscapes (Zope, 2017; Archer, 2007, Gilman, 2002). However, recent reviews have suggested the evidence base for land-cover change impacts on hydrological functioning is still poorly formed (Guzha et al. 2018; Burgess-Gamble et al., 2017; Dadson et al. 2017; Rogger et al. 2017). Despite the lack of evidence, nature-based

programmes to reduce flood and drought risk are now being funded. In the UK, for example, there is a programme of Natural Flood Management (NFM) which includes localised measures such as storage ponds and woody debris dams (Nicholson et al., 2020; Nisbet et al., 2015), and extensive measures such as woodland planting (Murphy et al., 2020), peatland restoration (Goudarzi et al., 2020; Shuttleworth et al., 2019) and reducing grazing intensity (Gao et al., 2015). Each initiative is designed to increase water storage or 'slow the flow' of runoff by enhancing roughness and decreasing the connectivity of the landscape. The influence of soil and vegetation properties on water storage and runoff generation for different habitats needs further research in order to support landscape-scale assessments of NFM (Burgess-Gamble et al., 2017; Environment Agency and CBEC, 2017; Forbes et al., 2015; Rogger et al., 2017; Strosser et al., 2015; WG POM, 2014; World Wildlife Fund, 2016).

In the UK, NFM initiatives are centred on headwater landscapes which typically have a cool, wet climate and are underlain by organo-mineral soils (OM soils). OM soils span multiple soil classification groups and are defined by the depth of surface organic material, generally <40 cm deep, and the organic content of that surface material, generally >20 % (Forestry Commission, 2016; Holden et al., 2007; Joint Nature Conservation Committee, 2011; Smith et al., 2007). Very little is known globally about the hydrological function of OM soils, despite their common occurrence (Avery, 1990; Bol et al., 2011; Cranfield University, 2018; Hodgson, 1997; Mackney et al., 1983; Scotland's Soils, 2013). OM soils cover 30.5% of Europe, including 10.5 % of England and Wales (of which 58.5 % are in uplands), and 50 % of Scotland and Ireland (Bol et al., 2011). While there are an increasing number of studies which recognise differences in soil properties between habitats and management types (Bogunovic et al., 2020; Carroll et al., 2004; Eze et al., 2020; Sun et al., 2018), and particularly reporting compaction effects (Drewry, 2006; Clarke et al., 2008; Wheeler and Evans, 2009), there have been limited studies that have focussed on soil hydrological functioning and NFM, especially for OM soils. Thus, further work is required to understand how OM soils respond to rainfall events and whether their management can be used as part of NFM strategies by catchment managers.

OM soils are often not suitable for arable agriculture, particularly in headwater areas. Thus, such areas are often managed as grasslands to support livestock. Grasslands account for

approximately 69 % of global agricultural land (Wood et al., 2000), including 60% of the UK (of which 46 % is 'semi-natural grassland' (Defra, 2016)). Grasslands are the most common land use for OM soils in England and Wales, accounting for approximately 30 % of total OM soil land cover (Bol et al., 2011). In upland England, 29 % of all rough grassland, 35 % of all bracken and 33 % of all acid grasslands are underlain by OM soils (Bol et al., 2011). There are a range of grassland habitat types and management styles, each of which may influence soil hydrological function and runoff production through influences on soil compaction (Drewry, 2006), surface roughness (Bond et al., 2020), deposition of organic matter and root penetration into the soil (Soulsby, 1993), interception of precipitation by vegetation (Nisbet, 2005) and evapotranspiration. Each of these factors may contribute to regulation of water within grasslands, determining the antecedent conditions which drive rainfall-runoff response in a storm event. Within-grassland variation may also be important, influencing connectivity of hillslopes and streams.

This study seeks to investigate the hydrological function of five upland arable farm-based grassland types, henceforth referred to as habitat types, which are underlain by OM soil and subject to varying management conditions as part of the same heterogenous grassland landscape. Physical and hydrological soil properties are investigated including the hydrological function of each grassland management regime in response to storm events.

## **2.3 Method**

### **2.3.1 Field site**

Field measurements were conducted in Swindale, a 2.66 km<sup>2</sup> U-shaped valley in the Lake District of northwest England (Figure 2.1; 54° 30'14.75"N, 2° 45' 56.91"W). Swindale has upland OM soils, predominantly Malvern 611a (Chromic Endoleptic Umbrisol) and Bangor 311e (Dystric Epileptic Histosol) soils, underlain by igneous shale and bedrock (Cranfield University, 2020). The U-shaped valley ranges between 270 m and 430 m elevation and forms part of a wider 15.3 km<sup>2</sup> catchment. In Shap, 5 km northeast of Swindale at 255 m above sea level, mean annual precipitation was 1779 mm between 1981 and 2010; mean of each daily maximum temperature at Shap was 11.5 °C, and mean daily minimum was 4.1 °C (Met Office, 2020). Swindale is part of a higher-level stewardship scheme (HLS) which

manages the upland grassland habitats as part of a working farm. HLS is an agri-environmental scheme in England which provides funding to land managers in return for environmentally conscious management (Natural England, 2012). This includes action such as creating and maintaining woodland, encouraging species-rich grassland or hay meadows, or protecting water quality.

Our sampling was conducted in a paired-plot comparison over one section of hillslope so that direct comparisons between adjacent habitats could be made, factoring in elevation, aspect, and making a reasonable assumption of similar climatic conditions (Figures 2.1 and 2.2). A section of hillslope was chosen representing five farm-based habitats which have the same Malvern 611a (Chromic Endoleptic Umbrisol) underlying soil type (Cranfield University, 2020) but represent different commonly occurring UK upland grassland types. These habitats were Good Grazing and Rough Grazing, Excluded (rank grassland not used for grazing), Haymeadows and Bracken (Table 2.1); these habitats were also the most common habitat types within the farm boundary, each representing between 9.4 to 34 % of the total land cover. When compared to the 2007 CEH UK land cover map (Morton et al., 2011), all sampled Swindale grassland types occur within the three most populous land-use categories: Improved Grassland (UK cover 23.60 %, includes Good Grazing, Rough Grazing & Hay Meadows), Rough Grassland (UK cover 5.48 %, includes the Excluded habitat) and Acid Grassland (UK cover 6.94 %, includes Bracken).

Good Grazing and Rough Grazing are both low-density habitats which have been given the grade of 'Good' or 'Rough' based on the quality of fodder and the extent to which the sward is allowed to grow before grazing. Rough Grazing is also situated on the higher, steeper hillslopes. Bracken, which dominates the upper hillslopes above 330 m elevation in Swindale, grows within the Rough Grazing and Excluded habitats. Each of these habitats have distinctive, but potentially adaptable, management strategies which may influence hydrological functions.

Seven years prior to this study, the Excluded habitat was created by fencing-off the watercourses from grazing using wide buffer strips throughout the catchment. Therefore,

the Excluded habitat is relatively new and would have previously been subject to low-density grazing under the Good Grazing or Rough Grazing management.

Precipitation data were acquired from Mickleden, approximately 24 km southwest of Swindale (Middle Fell Farm telemetry, Station number 586820, Environment Agency (2020)). The rain gauge recorded 15-minute interval data between May 2019 and March 2020. Flow gauge data for Swindale Beck was also recorded at 15-minute intervals from the United Utilities Crump Weir located at the Swindale Beck abstraction point to Haweswater Reservoir (Figure 2.1).

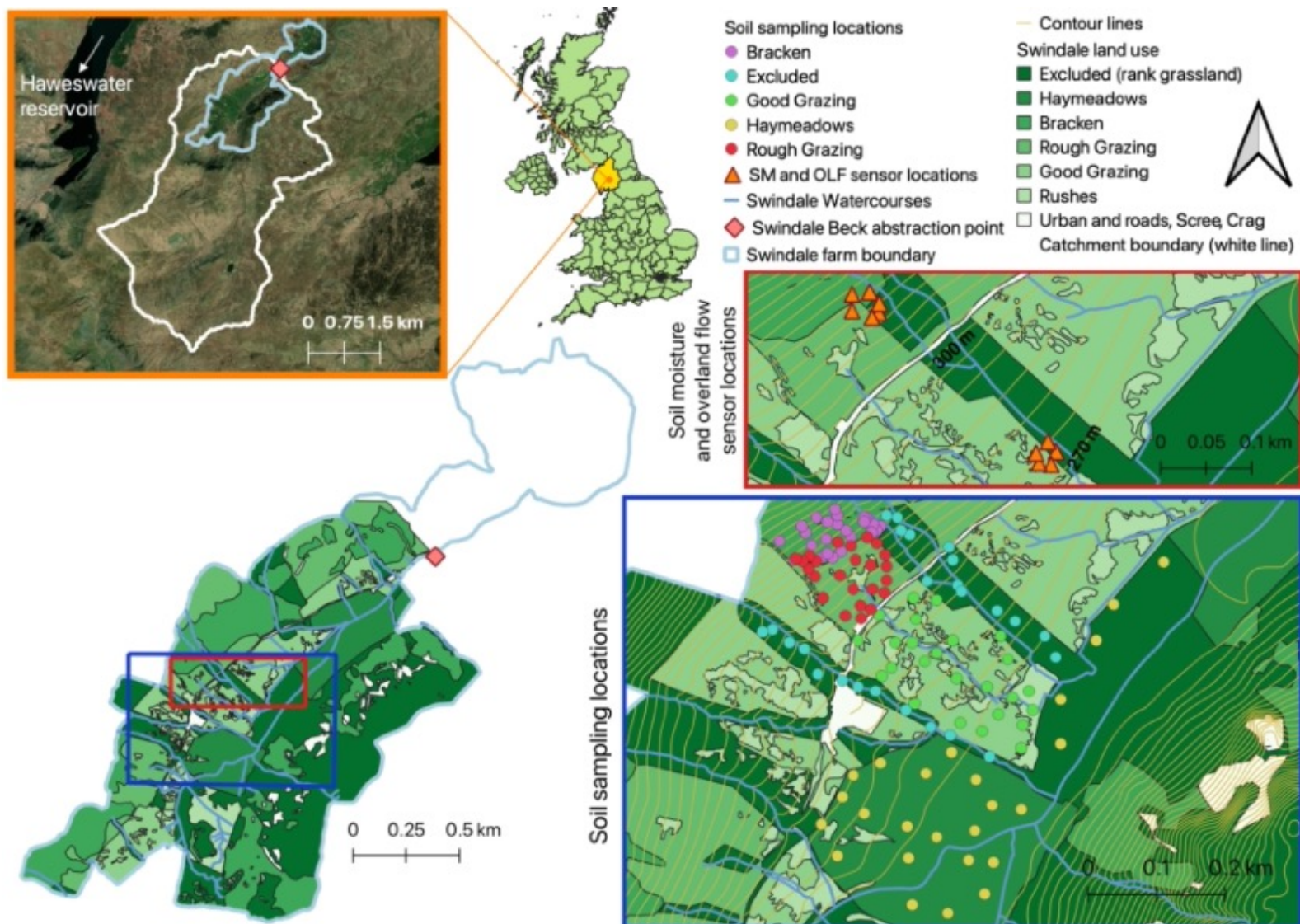

Figure 2.1: Swindale location and location of all physical soil sampling and soil moisture (SM in legend) and overland flow (OLF in legend) sensors. B = Bracken, E = Excluded (Rank Grassland), GG = Good Grazing, RG = Rough Grazing. For schematic diagram showing hydrological (soil moisture and overland flow) sensor locations, see Figure 2.2.



Table 2.1: Grassland habitats in Swindale. Elevation range refers to the range over which samples were taken and sensors placed as part of this study. Average slope and approximate land cover have been calculated using habitat cover over the Swindale Farm to the abstraction point (filled-in land use shown in Figure 2.1, left, bottom corner). †SSSI is a Site of Special Scientific Interest, a conservation designation in the UK which gives legal protection to land with features of particular interest such as its wildlife, geology or landforms.

Study section	Habitat name	Elevation range (m)	Dominant species	Description and Management		
		Average slope (degrees)				
		Approx. land cover in Swindale (%)				
Physical soil properties only	Hay Meadows	266 – 285 m	Grasses: <i>Holcus lanatus</i> , <i>Anthoxanthum odoratum</i> and <i>Cynosurus cristatus</i> Broadleaf species: <i>Rhinanthus minor</i> , <i>Trifolium dubium</i> , <i>Trifolium pratense</i> and <i>Plantago lanceolata</i> .	Hay Meadows are species-rich grasslands in which no single species dominates. Parts of Swindale represent a typical upland hay meadow: species rich with a SSSI† designation in parts of Swindale. Left ungrazed from March throughout the spring and summer months until cutting at the first opportunity after 25 <sup>th</sup> July. After this, the Hay Meadows are lightly grazed through the winter months while sufficient fodder remains.		
		5.4 °				
		9.5 %				
Physical soil and soil hydrological properties	Bracken	330 – 355 m	Bracken: <i>Pteridium aquilinum</i>	Bracken is the largest, most common native fern species in the UK and grows in dense swathes favouring dry, acid soils (Wildlife Trust, 2020). In Swindale, Bracken grows within the ‘Rough’ Grazing and Excluded habitats on the upper slopes above 330 m elevation.		
		22.4 °				
		24.4 %				
	Low-density Grazing	Good Grazing	266 – 300 m	Grasses: <i>Festuca ovina</i> , <i>Agrostis spp.</i> and <i>Cynosurus cristatus</i> Moss species: <i>Rhytidiadelphus squarrosus</i> Broadleaf species: <i>Trifolium repens</i> , <i>Luzula campestris</i> and <i>Rumex acetosella</i> .	The definition of low-density grazing on upland pasture varies greatly. In Swindale, stock density is very variable throughout the year. Most stock spend bulk of summer months out of Swindale on common land, returning for short periods for treatments, shearing and separating lambs from ewes. Stock mostly sent away for winter months.	
			12.0 °			
			11.5 %			
		Rough Grazing	335 – 340 m			
			16.2 °			
			12.1 %			
	Excluded (Rank Grassland)		270 – 330 m	Grasses: <i>Dactylis glomerata</i> , <i>Holcus lanatus</i> , <i>Agrostis capillaris</i> , <i>Anthoxanthum odoratum</i> , <i>Festuca spp.</i> Broadleaf: <i>Ranunculus repens</i> , <i>Lotus pedunculatus</i> , and <i>Ranunculus acris</i>	Typically species poor, Rank Grassland is dominated by tall, tussocky and coarse grass species and is produced in unmanaged, ungrazed grasslands. In Swindale, Rank Grassland is the result of grazed fields being fenced-off for a period of seven years without cutting or grazing. No management currently applied in Swindale	
14.8 °						
34.0 %						
				Maximum 2.66 ewes plus lambs per hectare		

### 2.3.2 Soil properties

Soil properties were analysed over the five habitats, encompassing valley bottom (270 m) to steep upper slopes (330 m). Three soil pits per habitat were dug in the Upper and Lower slope plots to describe the OM soil horizons present. From the horizons identified, physical attributes which may influence soil hydrological function were assessed. Soil samples were then taken across the width and depth of each habitat in the hillslope and all habitats had the same aspect. To prevent elevation bias, each habitat was divided into sections using 5 m contour lines and the same number of samples were taken randomly along each line (Figure 2.1). In total, 125 intact soil samples were collected at 0-5 cm depth between November 2018 and May 2019, 25 for each habitat. Since bedrock was common below 5 cm depth, intact soil cores were collected as near-surface samples only.

Samples were analysed in the laboratory for saturated hydraulic conductivity ( $K_s$ ) using an Eijkelkamp 25 place permeameter. Following  $K_s$  measurement, saturated intact soil cores were transferred to pre-weighed metal containers and dried overnight at 105 °C to remove moisture and then reweighed to determine bulk density. Total organic matter ( $TOM$ , %) was calculated using loss on ignition at 550 °C.

Shapiro-Wilkes tests showed that bulk density and  $TOM$  were normally distributed, whereas the  $K_s$  distribution was non-normal. As a result, bulk density and  $TOM$  were analysed using ANOVA and Tukey's post-hoc tests, whereas  $K_s$  data were analysed using non-normal Kruskal-Wallis and Dunn's post-hoc tests. The relationship between soil properties was investigated using Spearman's rank (Figure A1.1, Appendix A1).

### 2.3.3 Hydrological monitoring

Hydrological monitoring occurred between May 2019 and March 2020 over four habitat types, using a paired-plot method. The paired-plot approach reduced spatial or temporal influences from factors such as elevation, underlying geology or storm event tracking. The Hay Meadows habitat was not included in the hydrological instrumentation because, being at the bottom of the hillslope, it did not have an equal-elevation comparison to another habitat and was known to collect water as part of the natural floodplain.

Two paired-plot sites were chosen, one on the 'Upper Slopes' incorporating Rough Grazing, Bracken and Excluded habitats, and one on the 'Lower Slopes' incorporating Good Grazing and Excluded (Figure 2.1, Table 2.1, Figure 2.2). Although Bracken grew in both the Excluded and Rough Grazing habitat, it has been included as a separate habitat; Bracken is generally avoided by livestock and its density precludes growth of the vegetation species otherwise found in the Excluded and Rough Grazing habitats. Each paired plot contained a series of 5TM Campbell Scientific soil moisture sensors at 5 cm, 10 cm and 15 cm depth, wired in series to an Arduino data logger which measured percentage soil moisture at 15-minute intervals. Soil moisture sensors were calibrated using the method by METER Environment (2020). At the soil surface, an overland flow sensor, made following the design by Goulsbra (2011), measured the absence or presence of overland flow at 5-minute intervals (Figure 2.2).

For clarity, when referring to the soil moisture and overland flow sensors, individual sensors henceforth are referred to by the location for which they were assigned (Figure 2.1) where E represents the Excluded habitat, RG represents Rough Grazing, B represents Bracken and GG represents Good Grazing. The number following each habitat abbreviation represents its position (Figure 2.2). A full list of abbreviations used in this manuscript can be found in Appendix A2 (Tables A2.1 & A2.2).

Some data gaps occurred during the operation of the soil moisture sensors due to power source and equipment failures, and equipment tampering. Consequently, the period of time for which the soil moisture sensors were operational varied by location. The Upper Slope data ran for two periods, May 2019 to August 2019 and December 2019 to March 2020, during which all sensors were operational. The Lower Slope data were subject to more difficulties. Sensors for the habitats E4 and GG1 were operational May 2019 to October 2019 and mid-November to December 2019. All other sensors were operational mid-September to October 2019 and mid-November to December 2019 with occasional other scattered data points. The temporal distribution of soil moisture data is shown in Appendix A3 (Figures A3.1 & A3.2). The operation of the overland flow sensors and total time overland flow was present per habitat is shown in Appendix A4.

Due to soil moisture sensors operating for different time periods (Appendix A3, Table A3.1), a matched-records approach was adopted, analysing data for time periods when all sensors were operational across each slope position.

For the Upper Slopes, 9526 matched records were available during which 808.4 mm rain fell; 9526 records accounted for 35.7 % of the total possible records between May 2019 and March 2020. For the Lower Slopes, 3181 matched records were available during which 246.6 mm fell. This accounted for 11.9 % of the total possible records. For both slope positions, periods of drought and large storm events were included in the matched-records data.

Since the matched records data were not normally distributed, a Kruskal-Wallis test was used to analyse difference in soil moisture between habitats within each slope position and by sensor depth. Tests were repeated to examine storm and drought conditions using the top and bottom 1 % of soil moisture data.

Soil moisture was analysed using a general linear model for the sensors at 5 cm depth, where topsoil soil moisture is thought to be strongly connected to runoff production (Meißl et al., 2020; Huza et al., 2014). The model predicted soil moisture and cumulative rainfall by habitat per storm event, based on scaled variable data. Scaling is a process by which each variable entry for soil moisture and cumulative rainfall was subtracted from the mean and divided by the standard deviation, making both variables unitless, therefore comparable.

In combination with overland flow and rainfall data, we tested whether there was a soil moisture threshold at which overland flow occurred. soil moisture thresholds ranging between 5 – 50 % soil moisture were chosen for which the percentage overland flow presence was determined. The influence of seasonality on overland flow at different soil moisture thresholds was also tested.

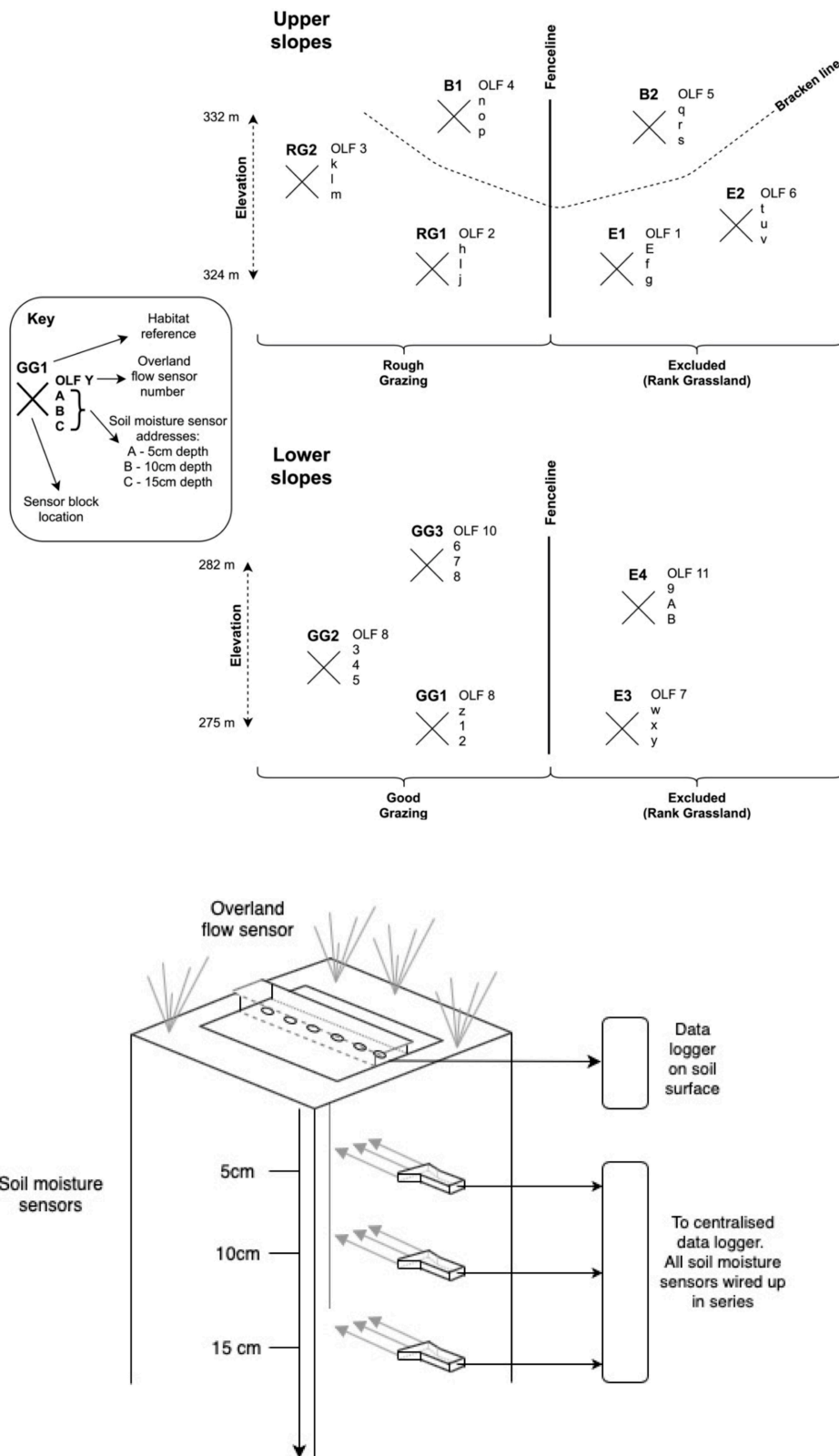

Figure 2.2: Schematic of the sensor installation. Above: the location of soil moisture and overland flow sensors in Swindale. Below: the configuration of soil moisture and overland flow sensors at each sensor block location.

## 2.4 Results

Results are split into three sections: soil profiling, soil properties and hydrological monitoring.

### 2.4.1 Soil profile description

Soil pits were always less than 30 cm deep before reaching large pieces of underlying bedrock which were impenetrable with hand tools. At depths greater than 5 cm, smaller pieces of shale up to approximately 5 cm diameter were present throughout the soil profile. The Upper Slopes had a more developed soil profile than the Lower Slopes. For the Upper Slopes an O/A surface organic horizon, approximately 7 cm deep, overlay an eluviated (E) horizon, approximately 8 cm deep, which contained a higher clay content and leached mineral and organic material. Underlying the O/A and E horizons, a subsoil B horizon, approximately 9 cm deep, overlay the base shale (C) horizon. In comparison, the Lower Slope soil profiles consisted of one O/A horizon directly overlying the parent-material C horizon.



*Figure 2.3: Representative soil profiles for the Upper (left) and Lower (right) slope sampling locations*

## 2.4.2 Soil properties

The relationships between  $K_s$ , bulk density and  $TOM$  are shown in Appendix A1.  $TOM$  and bulk density were found to be significant negatively correlated across the whole dataset ( $R^2=-0.82$ ,  $p<0.001$ ) and for individual habitats ( $p<0.05$ ). A significant negative correlation was also found between bulk density and  $K_s$  when examining all soil samples ( $R^2=-0.21$ ,  $p=0.019$ ), however when this correlation was tested for individual habitats only that for Bracken was significant ( $R^2=-0.69$ ,  $p<0.001$ ). No correlation was found between  $TOM$  and  $K_s$ .

Within the area sampled, elevation did not have a significant influence over any soil properties measured ( $p>0.05$ ). Mean  $TOM$  was highest in the Haymeadow (24.6 %) followed by Good Grazing (23.3 %), Bracken (22.2 %), Excluded (20.2 %) and Rough Grazing (17.4 %). Rough Grazing had significantly lower  $TOM$  than all other habitats, and Excluded  $TOM$  was significantly lower than that for Bracken, Good Grazing and Hay Meadows (Figure 2.4,  $p<0.05$ ). Good Grazing  $TOM$  was not significantly different to that of Bracken and Haymeadows, however Haymeadows had significantly higher  $TOM$  to Bracken (Figure 2.4,  $p=0.047$ ). Variability in  $TOM$  was highest for Good Grazing, having an interquartile range of 7.0 %, and lowest for Rough Grazing with an interquartile range of 3.6 %.

Rough Grazing had significantly higher bulk density than all other habitats with a mean of  $0.768 \text{ g cm}^{-3}$ , followed by Excluded ( $0.654 \text{ g cm}^{-3}$ ), Bracken ( $0.618 \text{ g cm}^{-3}$ ), Hay Meadows ( $0.568 \text{ g cm}^{-3}$ ) and Good Grazing ( $0.562 \text{ g cm}^{-3}$ ) (Figure 2.4). The latter three were not significantly different to one another, while Excluded had significantly higher bulk density compared to Good Grazing and Haymeadows (Figure 2.4,  $p<0.05$ ). The interquartile range was greatest for Good Grazing ( $0.208 \text{ g cm}^{-3}$ ).

$K_s$  was high for all habitats, ranging across several orders of magnitude from  $1.3 \times 10^{-3}$  to  $1.5 \times 10^2 \text{ m day}^{-1}$  with a median of  $2.4 \text{ m day}^{-1}$ , suggesting that infiltration-excess overland flow was unlikely to occur across most of the landscape studied. Median  $K_s$  was highest in Bracken followed by Excluded, Good Grazing, Rough Grazing and Haymeadows (Figure 2.4).  $K_s$  varied significantly between habitats but within habitats there was up to three orders of magnitude variation.  $K_s$  for Bracken was significantly greater than that for Good Grazing,

Hay Meadows and Rough Grazing while  $K_s$  for Excluded was significantly greater than that for Hay Meadows and Rough Grazing.  $K_s$  for Good Grazing was significantly greater than that for Hay Meadows (Figure 2.4).

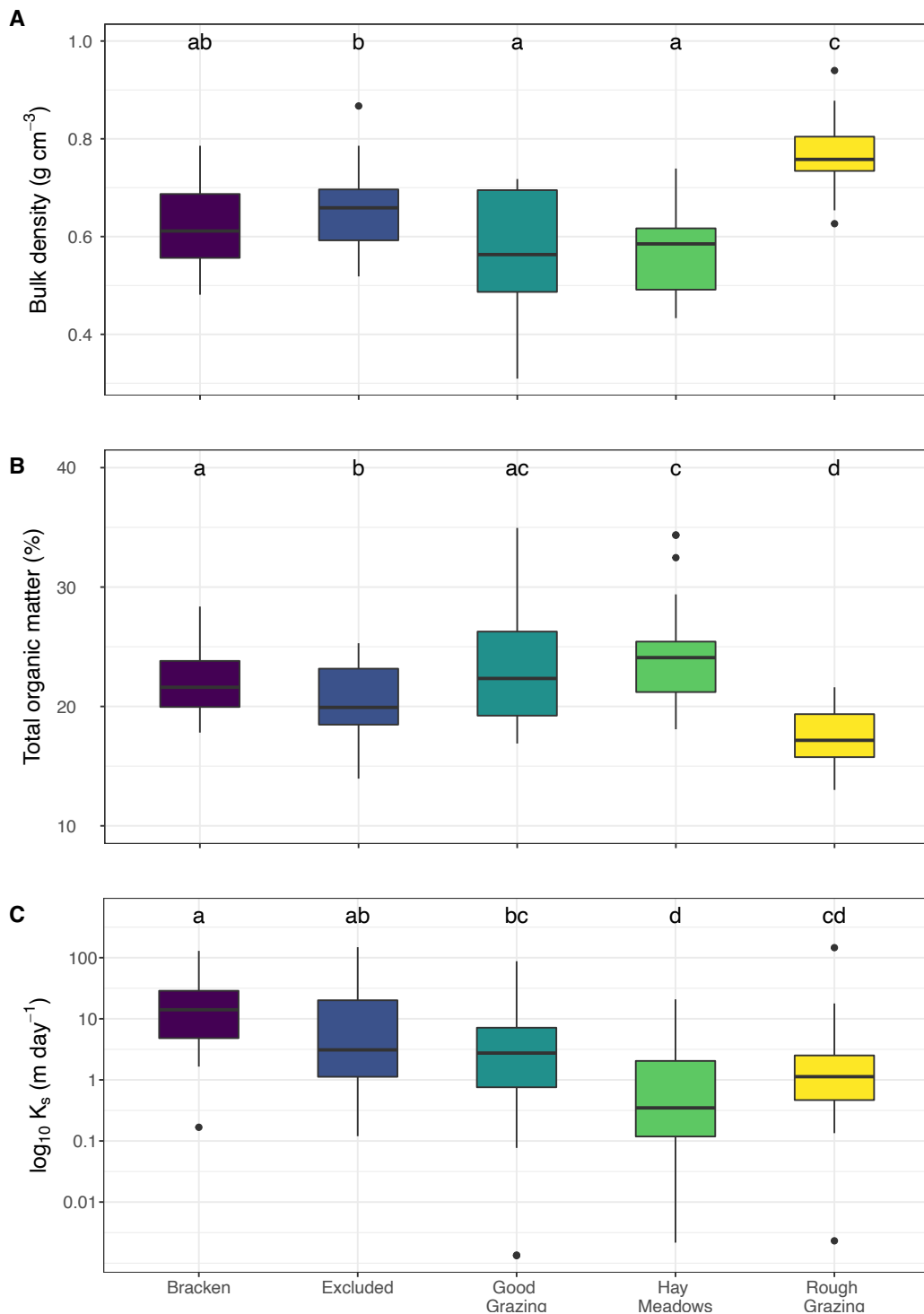

Figure 2.4: Soil properties for Bracken, Excluded (Rank Grassland), Good Grazing, Hay Meadows and Rough Grazing habitats. Boxplots show the range, quartiles and median data for each soil property; A) Bulk density, B) Total Organic Matter and C)  $K_s$ . Statistical significance is shown by the letters above each boxplot (Tukey's post-hoc test,  $p < 0.05$ ) where a shared letter indicates no statistical significance.



### 2.4.3 Hydrological monitoring

#### Soil moisture

Mean soil moisture was found to significantly vary between all habitats, at all depths, subject to the same precipitation (Dunn's post-hoc,  $p < 0.05$ ), except for between RG1 and B1 in the Upper Slopes at 5 cm depth (Figure 2.5). Although soil moisture varied by depth, a Dunn's post-hoc analysis of the whole dataset showed that, for the Upper Slopes, the driest habitat was RG1 followed by B1, E2, B2, E1 and RG2, the wettest habitat. However, when isolating the highest and lowest 1% of soil moisture data for each Upper Slope habitat, RG1 consistently had the highest soil moisture peaks, reaching a maximum 72 %, and the lowest soil moisture, as low as 4.7 %. Analysis of the top 1 % of soil moisture data showed that, excluding Bracken, Upper Slope habitats were grouped; RG1 and RG2 were statistically similar to each other, as were E1 and E2 (Dunn's post-hoc,  $p < 0.05$ ). Otherwise, habitats were statistically different (top 1 % data, Dunn's post-hoc,  $p < 0.05$ ). In comparison, for the bottom 1 % of soil moisture data, all habitats except E1 and E2 were statistically different to each other (bottom 1 % data, Dunn's post-hoc,  $p < 0.05$ ).

In the Lower Slopes, GG1 was the driest habitat, followed by E4, GG2, GG3 and E3, the wettest habitat. Looking at the top 1% of soil moisture data, E3 had the highest peaks, up to 96.2 % and GG1 had the lowest soil moisture, (23.9 %). Excluding GG1 and GG2, all Lower Slope habitats had significantly different soil moisture peaks (top 1 % data, Dunn's post-hoc,  $p < 0.05$ ) and all habitats were significantly different from each other during the driest 1 % period (Dunn's post-hoc,  $p < 0.05$ ).

Because of the nature of the matched-records analysis, slope positions were not comparable to each other using statistical tests. However, Upper Slope soil moisture was less variable (~ 25 % moisture for all three depths) than Lower Slope soil moisture. which was more varied, and large peaks in soil moisture were reflected in towering 'whiskers' and outlying datapoints (Figure 2.5). Maximum soil moisture in the Lower Slopes was frequently 1.5 times greater than median soil moisture. soil moisture was generally higher in the winter months (October to March) than summer (May to September).

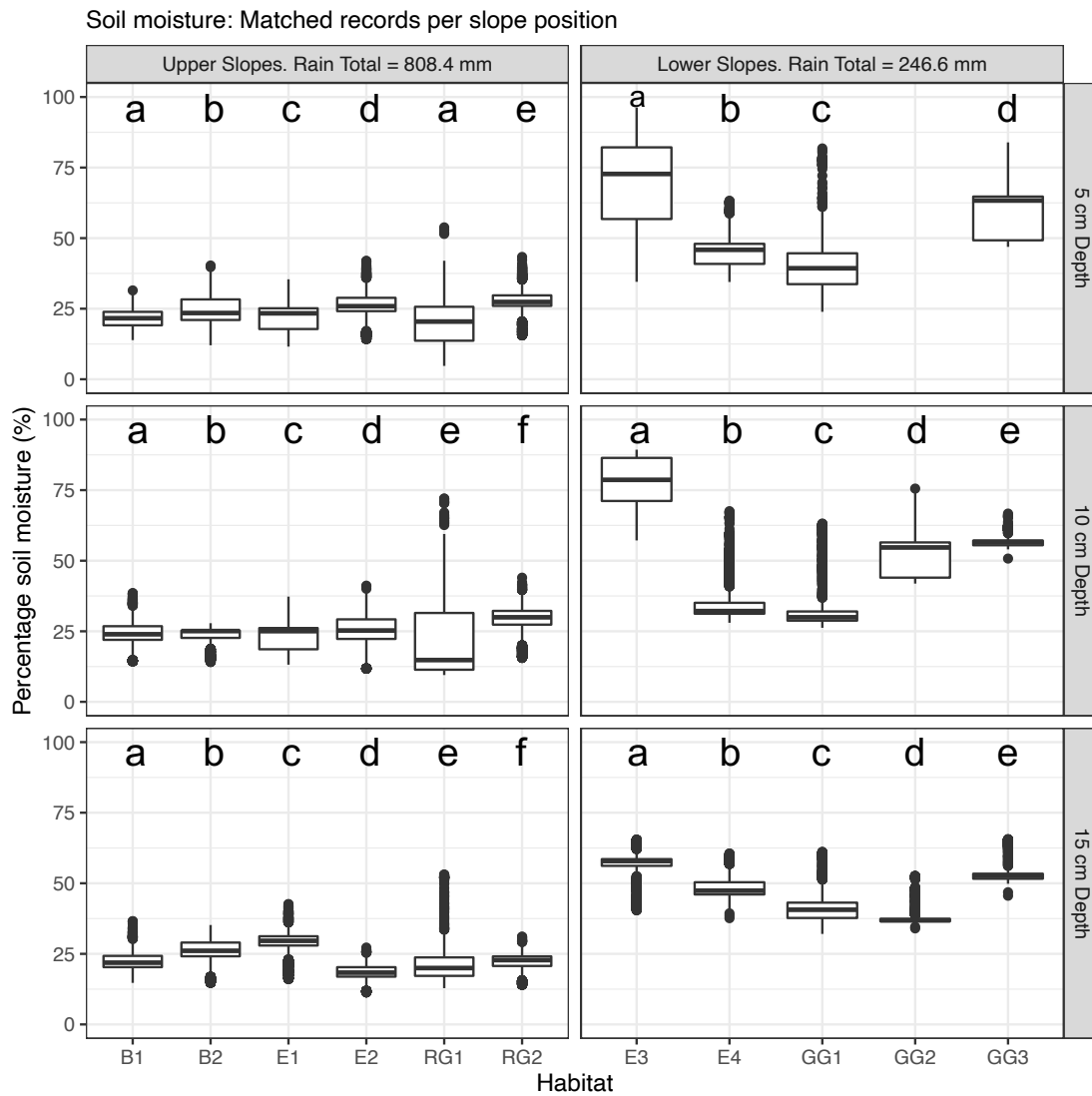

Figure 2.5: Soil moisture boxplots comparing habitats within each slope location by matched records (i.e., the same time periods for each habitat within that Slope position). Direct statistical comparisons cannot be drawn between the Upper and Lower slope sites. Statistical significance is represented by the letters above each graph facet (Dunn's post-hoc test,  $p < 0.05$ ) where comparisons are made between habitats within each Slope position and sensor depth, and a shared letter indicates no statistical significance. Boxplots show the range, quartiles and median data for each habitat. Outlying data (data points greater than  $1.5 \times$  inter-quartile range) were retained because measurements of extreme soil moisture values related to antecedent conditions and storm events.

## Overland flow

Overland flow occurred in all habitats between May 2019 and March 2020. In some habitats overland flow was very frequent, occurring > 60 % of the time in habitat GG3, 57 % of the time in habitat E3 and approximately 40 % of the time in habitats E1, E2 and E4 (Appendix A4). Habitat GG2 had overland flow present for 32.7 % of its operational timeframe and habitat B2 showed overland flow presence 19.8 % of the time. All other habitats produced overland flow <9 % of the time between May 2019 and March 2020.

Overland flow was consistently recorded more often in the Lower Slopes than the Upper Slopes and occurred more frequently in winter months than summer. Overland flow was also found to occur more often on the Excluded side of the hillslope than the grazed side, with the exception of habitat GG3 (Figure 2.6, Appendix A4). The Good Grazing habitat had the most varied overland flow occurrence within it, with 8-60 % occurrence, despite the sensors' relatively close proximity to each other. In comparison, within habitat and slope position categories for Excluded and Rough Grazing sensors recorded similar values. For example, E1 and E2 were operational >90 % of the time, recording overland flow presence 39 % and 40 % of the time respectively (Appendix A4).

The overland flow sensors were operational for the majority of the research period with most sensors recording data 65-99 % of the time; only sensor B1 was operational for less time, working just 27 % of the research period. Because of this, sensor B1 was excluded from a matched-record analysis which allowed direct comparison of habitats by monthly overland flow occurrence based on same-date, reliable records without bias towards seasonality or storm event (Figure 2.6).

Using the matched-records approach, with the exception of habitat E1, the majority of overland flow occurred in January and February, accounting for >50 % in all Lower-slope habitats. January and February also account for the greatest rainfall volume with 434.6 mm and 326.8 mm respectively falling within the timesteps analysed. Winter overland flow, represented by December, January and February matched-records data, accounted for >70 % overland flow presence in all habitats except E1 and B2, for which overland flow was most common in summer months. The third-most common month in which overland flow

occurred was July, accounting for >20 % overland flow in habitats E1, RG2, B2, E3, GG1 and GG3. July also received the third-highest volume of rainfall, 227.4 mm, which followed a drought period in June and early July.

There was no apparent soil moisture threshold at which overland flow occurred. Overland flow occurred at all soil moisture thresholds tested, even <5 %, and was not more common within a particular soil moisture bin width. Although soil moisture was generally lower in the summer months than in winter months, and overland flow was recorded more often in the winter than summer, there was no soil moisture threshold influence on overland flow identified when analysis was undertaken for summer and winter periods independently.

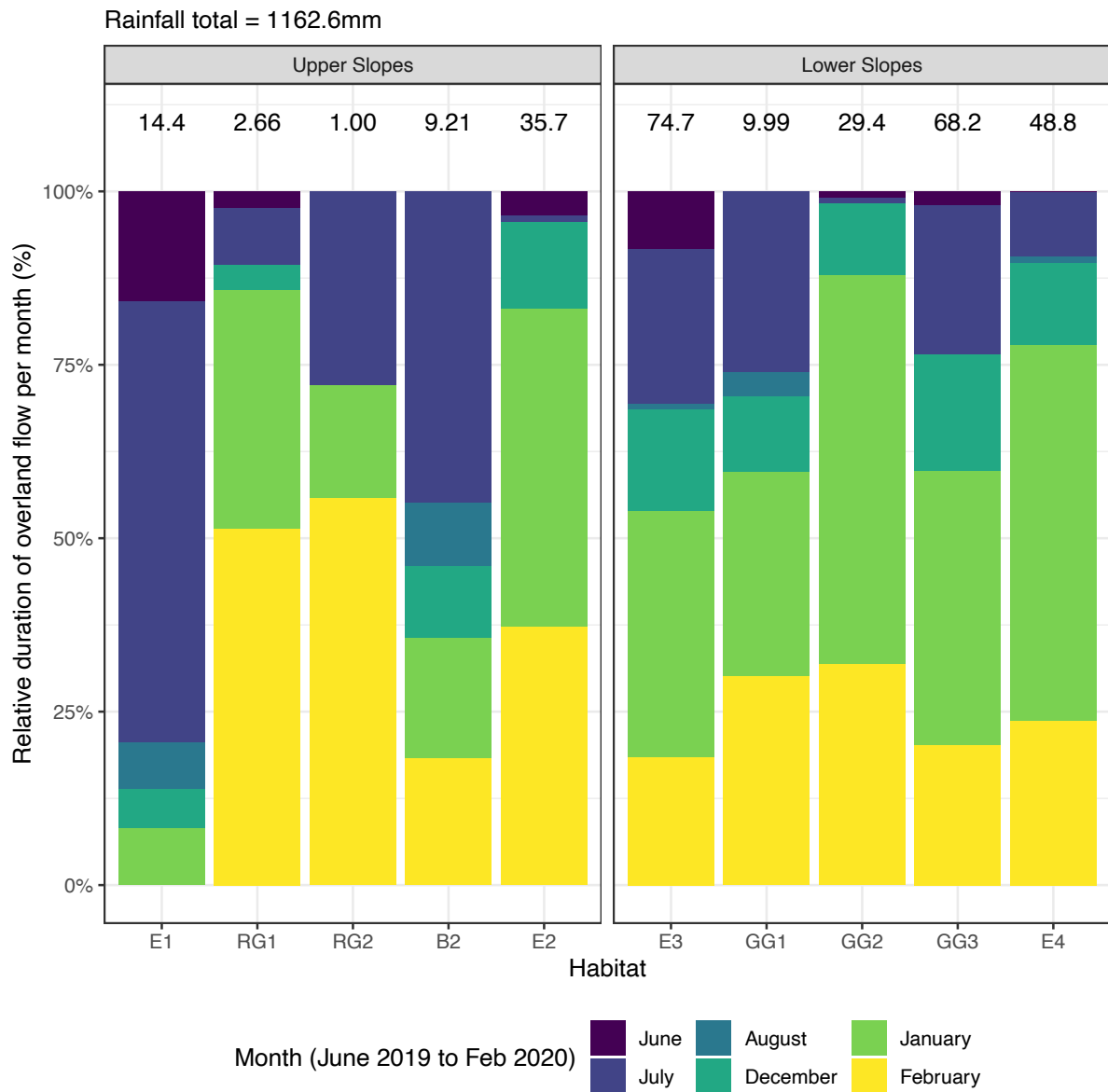

Figure 2.6: Relative overland flow presence per habitat per month. Calculated using a matched-records analysis including all sensor locations except B1. Above each stack the total duration of overland flow per habitat for all months is shown (%). Full details of the percentage overland flow and rainfall volume per month are shown in Appendix A4.

#### 2.4.4 Storm events

Between May 2019 and March 2020, 68 storm events occurred which had greater than or equal to 20 mm precipitation over a 24-hour period. Figures 2.6 and 2.7 show two storm events which were representative of the hillslope response to rainfall in the summer and winter. These two events represent the largest storms for which soil moisture data was available at both Upper and Lower slope locations. For 5 cm depth, a general linear model indicated that soil moisture for all habitats significantly varied from each other for both the July and December storm events tested (Figure 2.7 and Figure 2.8); both habitat type and the volume of cumulative rainfall were important in the model.

In both storm events, soil moisture was quick to respond to the onset of rain, rising almost immediately in response to rainfall. However, the summer response was more muted in comparison to the winter, gradually rising until peak rain and then falling gradually over the following 12 hours after which it had almost returned to the previous base-level moisture. The winter soil moisture was higher before the beginning of the storm than for the summer storm. However, soil moisture changes strongly in response to rainfall intensity, increasing soil moisture by up to 8 % before falling rapidly after each rain event. After 12 hours, soil moisture was at the pre-storm level again. Overland flow occurrence was more frequently recorded in the winter storm than the summer storm. However, both storms show a delay in overland flow response after rainfall and soil moisture rise, suggesting a saturation-excess overland flow response. For both storm events, habitat GG3 and E3 are the most sensitive to hydrological changes with overland flow occurrence quickly following any rainfall.

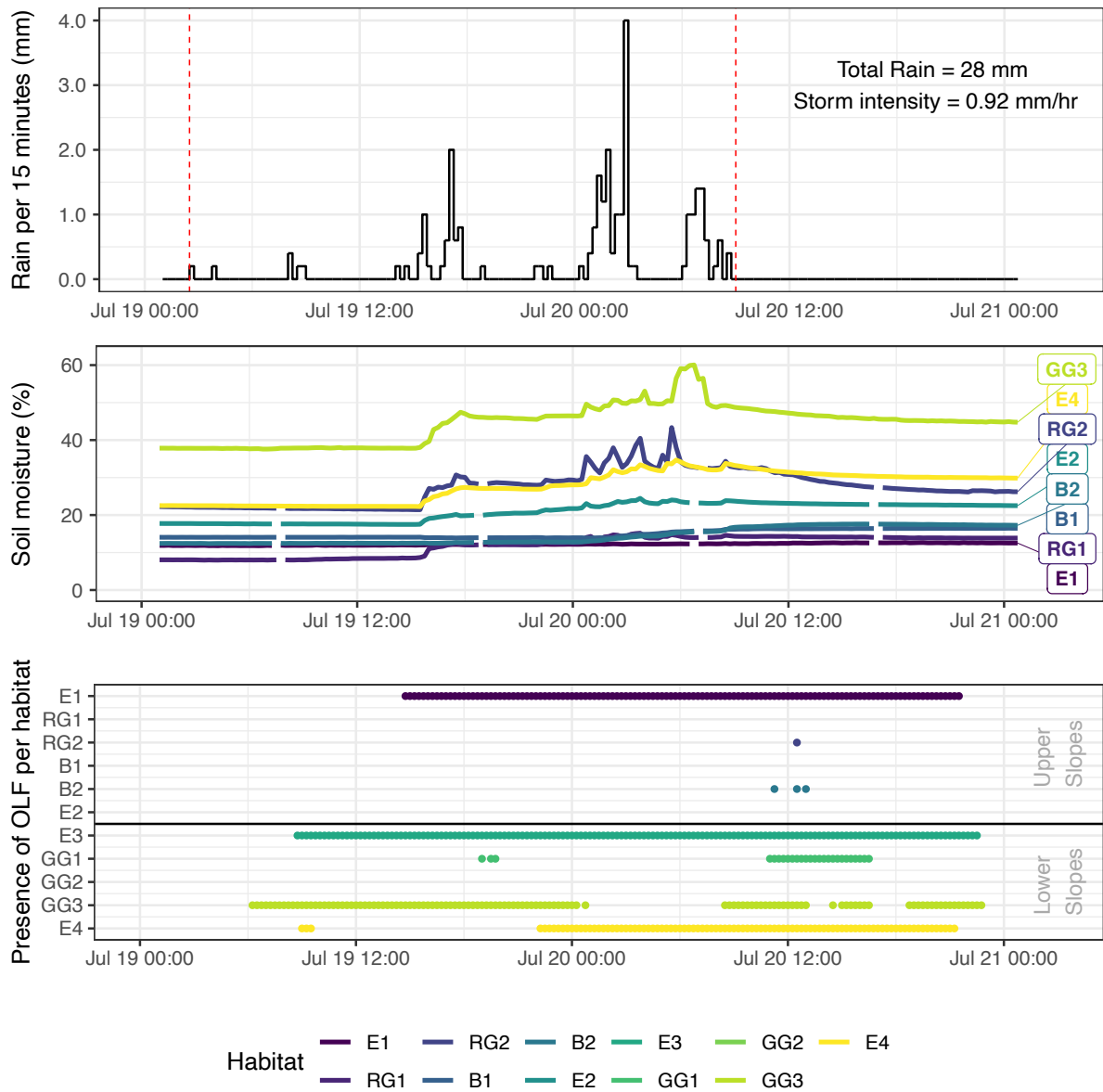

Figure 2.7: Rainfall, soil moisture (5 cm depth only) and presence of overland flow for a July 2019 storm

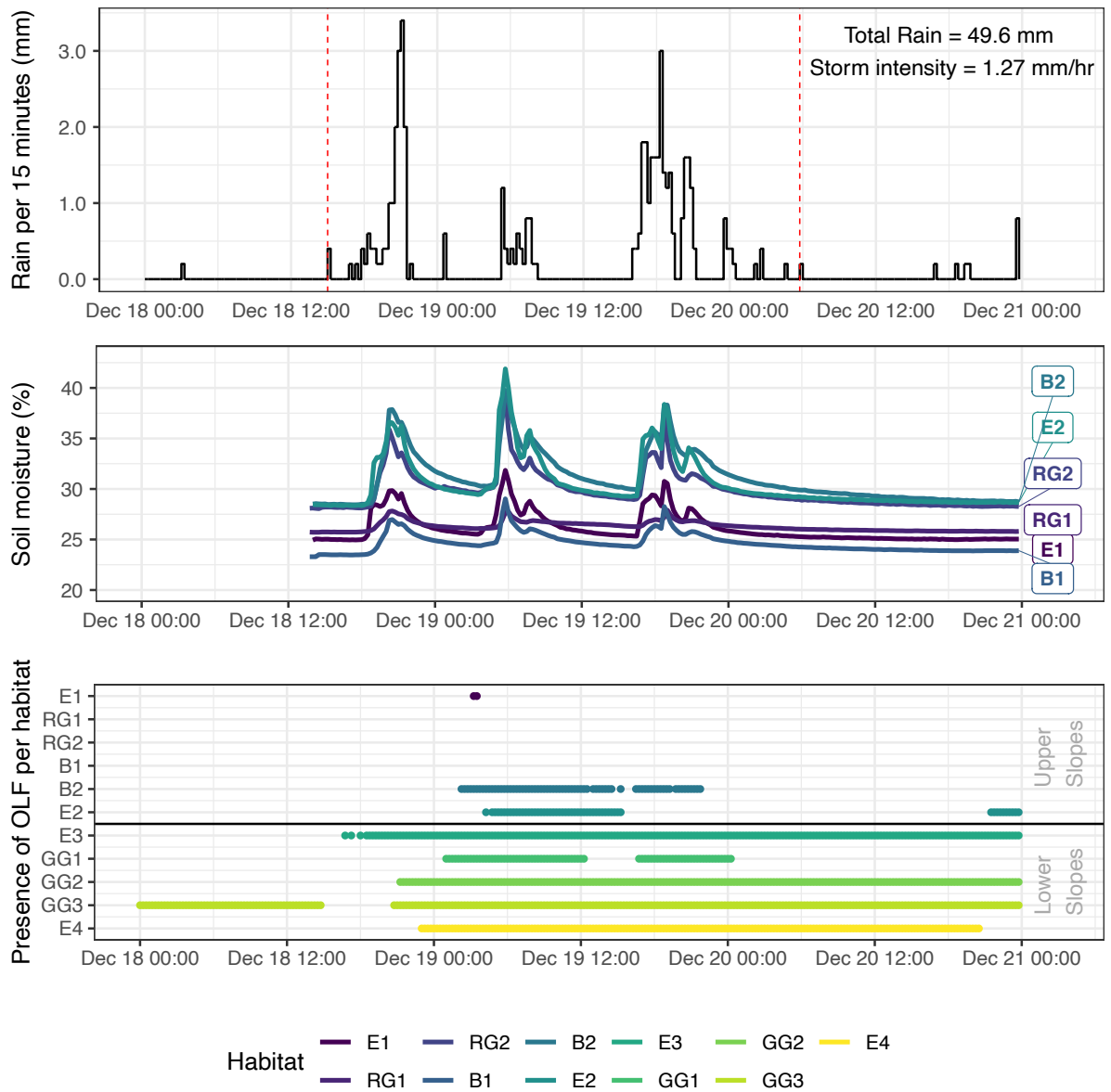

Figure 2.8: Rainfall, soil moisture (5 cm depth only) and presence of overland flow for a December 2019 storm



## 2.5 Discussion

Overland flow is an important feature in this upland OM soil system, frequently occurring in response to storm events. Results from this study recorded overland flow as being present or absent only, therefore it is impossible to make comment about the volume of overland flow that occurred in each habitat. Many studies (Carroll et al., 2004; Jordon, 2020; Marshall et al., 2014) suggest that overland flow should be more prevalent in grazed habitats than ungrazed, and while the sensor location which recorded overland flow presence most often was GG3, a grazed habitat, overland flow occurred more frequently overall in Excluded habitats. The prevalence of overland flow in Excluded habitats may be a consequence of enhanced storage and slowing of flow in the more highly vegetated ungrazed habitats, through which surface water cannot flow downslope as readily and therefore the time for which overland flow lasts is longer. Confirmatory evidence for this hypothesis comes from Bond et al. (2020) who used overland flow velocity experiments in the Swindale catchment to show that surface roughness in Rank Grassland was associated with an overland flow velocity half that of the velocity in Haymeadows. Thus, the Excluded habitat, the same habitat which Bond et al (2020) called Rank Grassland, retained overland flow for longer which could be key for NFM implementation.

The common presence of overland flow in all habitats combined with high  $K_s$  (Figure 2.4), the shallow soil profiles (Figure 2.3) and the delayed overland flow onset after storm events (Figure 2.7, Figure 2.8), suggests a saturation-excess overland flow mechanism dominates in the upland grassland system studied. In many catchments, sub-surface properties are thought to play a key influence on catchment hydrology (Anderson and Burt, 1990). In Swindale, we hypothesise that shallow soils and large pieces of underlying shale slow groundwater percolation allowing soil saturation to occur quickly, despite the high soil  $K_s$  values. The Lower Slope habitats were more susceptible to overland flow with net accumulation from upslope, and shallowest soils and higher soil moisture throughout the year, including soil moisture peaks up to 96.2 % (Figure 2.5).

Despite the above, there was not an obvious soil moisture threshold at which overland flow occurred. Analysis of storm events produced some evidence to suggest that there was

greater retention and slower release of water in the Excluded habitats than the grazed habitats, shown by prolonged overland flow presence. The difference between habitats may be related to both retention of water by the increased volume of vegetation in the ungrazed sections of the hillslope and to the physical soil properties, for which  $K_s$  was highest for the Excluded and Bracken habitats (where Bracken was 50 % within the Excluded habitat and generally avoided by grazing livestock).

When compared on a matched-records basis, mean soil moisture was found to significantly vary between all habitats at all depths with the exception of habitats B1 and RG1 at 5 cm depth (Figure 2.5). The variation in soil moisture highlights strong heterogeneity within grassland habitats, even within those subject to the same management and weather conditions. Nevertheless, grouping was observed when comparing the top and bottom 1 % of data where some sensor locations within a habitat type were statistically similar (RG1 & RG2, E1 & E2, GG1 & GG2). Grouping suggests that management of grassland habitats may have a dominant influence over soil moisture extremes.

As expected, soil moisture was higher year-round in the lower slope habitats and higher in winter months compared to summer, however significant within-habitat variation for both soil moisture and soil properties may be due to localised differences in compaction, rooting and micro-topography (Hu et al., 2020; Ghestem et al., 2011; Clarke et al., 2008). These localised differences may also account for the absence of anticipated grouping of grazed versus excluded habitats in terms of mean soil moisture, bulk density, *TOM* and  $K_s$ . It may be that rooting and compaction out-weigh each other in affecting infiltration and runoff for these habitats. Certainly, the higher overland flow frequency in the Excluded habitat does not translate to a higher soil moisture; this may also be a reflection of volume versus frequency of overland flow where both Low-density Grazing and Excluded habitats were subject to the same volume of rain which produced statistically similar soil moisture but differing durations of overland flow presence.

Bulk density, *TOM* and  $K_s$  were significantly different between most grassland types. The differences in soil properties are likely due to the influence of management which alter organic matter inputs through grazing and vegetation controls. Vegetation species present

and grazing density are naturally heterogenous within each habitat type, explaining high within-habitat variability alongside micro-topographical influences. For example, high *TOM* in the Haymeadows may be a consequence of floodplain deposition or waterlogging affecting breakdown of organic matter. Although, as expected, *TOM* and  $K_s$  were found to be significantly negatively correlated to bulk density (Figure S1.1), there was no strong association between management and soil properties, especially when comparing grazed and ungrazed habitats (Figure 2.4). Again, this may be the result of strong within-habitat heterogeneity, itself a partial consequence of low-density grazing and relatively newly implemented exclusion zones.  $K_s$  had especially high variability, and the values recorded were similar to the highest found in temperate or high latitude peatlands: a literature summary of peat  $K_s$  by Branham and Strack (2014) suggests values between  $8.64 \times 10^1 \text{ m day}^{-1}$  and  $8.64 \times 10^{-4} \text{ m day}^{-1}$  across eight studies. This suggests that, for surface properties at least, OM soils have a similar hydrological response to peat, further supported by the dominance of saturation-excess overland flow.

Many studies compare land uses for which management has been separately applied for decades. In this study, the Excluded habitat had only been in operation for seven years following grazing. If the Excluded habitat had the same soil properties as the low-density grazing habitats prior to being fenced-off, then we have evidence that changes in grassland management may quickly alter soil properties and hydrological conditions.

The prevalence of overland flow and the strong hydrological differences between habitats suggests that, at a hillslope scale, the largest influence on flood mitigation in these shallow, high  $K_s$ , OM-soil grassland systems is surface roughness. While soil properties are essential in controlling antecedent conditions and the rate at which habitats wet-up, once overland flow is produced, the primary control is vegetative roughness. Research by Bond et al. (2020) showed that overland flow velocity significantly varies between grassland habitats as a consequence of land management and seasonality, the primary controls affecting roughness. Since roughness changes occur in the short to medium term, land management may affect flood and drought mitigation on a shorter timescale than many studies suggest. Consequently, roughness may be important as a fast-acting land-use change which serves as initial NFM approach while long-term changes in soil properties more slowly accumulate

further benefits. A mosaiced upland landscape can utilise NFM to produce multiple ecological and environmental benefits where they are most required, such as in a high overland flow-producing area, in addition to maintaining economic practices such as livestock management.

Since overland flow is clearly an important factor in upland OM soil landscapes at the hillslope scale, modelling research should explicitly include overland flow processes. Modelling is needed to upscale our findings to catchment and landscape scales, accounting also for soil property changes as a result of management practice. Where landscape heterogeneity is becoming an increasingly important part of upland management, modelling should account for spatial differences, investigating best placement of NFM and how future landscapes may respond hydrologically with shifting soil properties. Therefore, further studies could incorporate a long-term before-after-control-impact approach which monitors changes in hydrological function with management interventions, and funders should be encouraged to invest in such long-term monitoring.

## **2.6 Conclusion**

In this research, we investigated the hydrological function of upland OM soils under differing grassland management. Bulk density, *TOM* and  $K_s$  were significantly associated with grassland type, suggesting that management of grasslands is important to OM soil properties. Overland flow occurred frequently across the upland study site, being present for up to 60 % of the research period and occurring more often in the Excluded habitat than under grazed conditions. Soil moisture was significantly different between habitats and between sensors within one habitat type; this was attributed to soil heterogeneity. Our research suggests that there is potential for upland grassland management on OM soils to be included as part of NFM, especially using surface roughness interventions. However, modelling is required to test the potential influence of grassland NFM techniques at a catchment scale.

## 2.7 References

- Anderson M.G. and Burt T.P. (1990) Subsurface runoff. In *Process Studies in Hillslope Hydrology*, Anderson M.G. and Burt T.P. (eds.), John Wiley & Sons: New York, pp. 365 – 400.
- Archer, D. R. (2007). The use of flow variability analysis to assess the impact of land use change on the paired Plynlimon catchments, mid-Wales. *Journal of Hydrology*, 347(3-4), 487-496.
- Avery, B. W. (1990). *Soils of the British Isles*. Wallingford: CAB International.
- Bogunovic, I., Telak, L. J., Pereira, P., Filipovic, V., Filipovic, L., Percin, A., . . . Comino, J. R. (2020). Land management impacts on soil properties and initial soil erosion processes in olives and vegetable crops. *Journal of Hydrology and Hydromechanics*, 68(4), 328-337.
- Bol, R., Blackwell, M., Emmett, B., Reynolds, B., Hall, J., Bhogal, A., & Ritz, K. (2011). *Assessment of the response of organo-mineral soils to change in management practices*. Sub-Project ii of Defra Project SP1106: Soil carbon: studies to explore greenhouse gas emissions and mitigation. DEFRA
- Bond, S., Kirkby, M. J., Johnston, J., Crowle, A., & Holden, J. (2020). Seasonal vegetation and management influence overland flow velocity and roughness in upland grasslands. *Hydrological Processes*, 34(18), 3777-3791.
- Branham, J. E., & Strack, M. (2014). Saturated hydraulic conductivity in Sphagnum-dominated peatlands: do microforms matter? *Hydrological Processes*, 28(14), 4352-4362.
- Burgess-Gamble, L., Ngai, R., Wilkinson, M., Nisbet, T., Pontee, N., Harvey, R., . . . Quinn, P. (2017). *Working with natural processes to reduce flood risk*. Bristol, UK: Environment Agency.
- Carroll, Z., Bird, S., Emmett, B., Reynolds, B., & Sinclair, F. (2004). Can tree shelterbelts on agricultural land reduce flood risk? *Soil Use and Management*, 20(3), 357-359.
- Clarke, M., Creamer, R., Deeks, L., Gowing, D., Holman, I., Jones, R., . . . Ritz, K. (2008). *Scoping study to assess soil compaction affecting upland and lowland grassland in England and Wales*. Final project (BD2304) report to Defra. London: DEFRA.
- Cranfield University. (2018). Soil Classification System for England and Wales. Available at: <http://www.landis.org.uk/downloads/classification.cfm> [Accessed 09/02/2018]
- Cranfield University. (2020). The Soils Guide [online]. Available at: [www.landis.org.uk](http://www.landis.org.uk) [Accessed 17/02/2020]
- Dadson, S. J., Hall, J. W., Murgatroyd, A., Acreman, M., Bates, P., Beven, K., . . . Lane, S. N. (2017). A restatement of the natural science evidence concerning catchment-based 'natural' flood management in the UK. *Proceedings of the Royal Society A: Mathematical, Physical and Engineering Sciences*, 473(2199), 20160706.
- Defra. (2016). *Key results by UK country: 1866 to 2016 [online]*. London: DEFRA. Available at: <https://www.gov.uk/government/statistical-data-sets/structure-of-the-agricultural-industry-in-england-and-the-uk-at-june>. [Accessed 18/02/2020]

- Drewry, J. (2006). Natural recovery of soil physical properties from treading damage of pastoral soils in New Zealand and Australia: a review. *Agriculture, Ecosystems & Environment*, 114(2-4), 159-169.
- Environment Agency. (2020). *Mickleden Precipitation. Station number 586820. Middle Fell Farm Telemetry*. Available via CMBLNC Info Requests.
- Environment Agency, & cbec. (2017). *Natural flood management toolbox, Guidance for working with natural processes in flood management schemes*. Inverness, UK: cbec eco-engineering.
- Eze, S., Dougill, A. J., Banwart, S. A., Hermans, T. D., Ligowe, I. S., & Thierfelder, C. (2020). Impacts of conservation agriculture on soil structure and hydraulic properties of Malawian agricultural systems. *Soil and Tillage Research*, 201, 104639.
- Forbes, H., Ball, K., & McLay, F. (2015). *Natural Flood Management Handbook*. Stirling, UK: SEPA.
- Forestry Commission. (2016). Standard and Guidance. Eligible Activities - Soil type Forestry Commission. Available at: <https://www.forestry.gov.uk/forestry/INFD-8J3QRL> [Accessed 07/02/2018]
- Gao, J., Kirkby, M., Grayson, R., & Holden, J. (2015). *Flood modelling and compaction studies for the Upper Ure Project UUCP1/2015*. Leeds: University of Leeds.
- Ghestem, M., Sidle, R. C., & Stokes, A. (2011). The influence of plant root systems on subsurface flow: implications for slope stability. *Bioscience* 61(11), 869-879.
- Gilman, K. (2002). *Modelling the effect of land use change in the upper Severn catchment on flood levels downstream* (Report 471). Peterborough: English Nature.
- Goudarzi, S., Milledge, D. G., Holden, J., Evans, M., Allott, T., & Shuttleworth, E. (2020). Blanket-peat restoration: numerical study of the underlying processes delivering Natural Flood Management benefits. *Water Resources Research*, 57(4), e2020WR029209.
- Goulsbra, C. (2011). *Monitoring the connectivity of hydrological pathways in a peatland headwater catchment*. (PhD Thesis), The University of Manchester.
- Guzha, A., Rufino, M. C., Okoth, S., Jacobs, S., Nóbrega, R. L. B. (2018). Impacts of land use and land cover change on surface runoff, discharge and low flows: Evidence from East Africa. *Journal of Hydrology: Regional Studies* 15, 49-67.
- Hodgson, J. M. (1997). *Soil Survey Field Handbook*. Soil Survey Technical Monograph No. 5. Harpenden, UK: Rothamsted Experimental Station.
- Holden, J., Chapman, P., Evans, M., Hubacek, K., Kay, P., & Warburton, J. (2007). *Vulnerability of organic soils in England and Wales*. Final technical report to DEFRA and Countryside Council for Wales. DEFRA Project SP0532. London: DEFRA.
- Hu, L., Bao, W., Shi, P., Wang, J., & Lu, M. (2020). Simulation of overland flow considering the influence of topographic depressions. *Scientific Reports* 10(1), 1-14.
- Huza, J., Teuling, A., Braud, I., Grazioli, J., Melsen, L., Nord, G., Raupach, T., & Uijlenhoet, R. (2014). Precipitation, soil moisture and runoff variability in a small river catchment (Ardèche, France) during HyMeX Special Observation Period 1. *Journal of Hydrology* 516, 330-342.

- Joint Nature Conservation Committee. (2011). *Towards an assessment of the state of UK Peatlands. JNCC report 445. ISSN 0963 8901*. Available at: <http://jncc.defra.gov.uk/page-5861> [Accessed 09/02/2020]
- Jordon, M. W. (2020). Does mixed vs separate sheep and cattle grazing reduce soil compaction? *Soil Use and Management*, 37(4), 822-831.
- Mackney, D., Hodgson, J., Hollis, J., & Staines, S. (1983). *Legend for the 1: 250,000 soil map of England and Wales*. Harpenden, UK: Soil Survey of England and Wales.
- Marshall, M., Ballard, C., Frogbrook, Z., Solloway, I., McIntyre, N., Reynolds, B., & Wheater, H. (2014). The impact of rural land management changes on soil hydraulic properties and runoff processes: results from experimental plots in upland UK. *Hydrological Processes*, 28(4), 2617-2629.
- Meißl, G., Zieher, T., & Geitner, C. (2020). Runoff response to rainfall events considering initial soil moisture—Analysis of 9-year records in a small Alpine catchment (Brixenbach valley, Tyrol, Austria). *Journal of Hydrology: Regional Studies* 30, 100711.
- Met Office. (2020). *UK Climate averages: Shap weather station 1981-2010*. Available at: <https://www.metoffice.gov.uk/research/climate/maps-and-data/uk-climate-averages/gcwn4cte6> [Accessed 09/01/2020].
- METER Environment. (2020). *Method A: Soil-specific calibrations for METER soil moisture sensors*. Available at: <https://www.metergroup.com/environment/articles/method-a-soil-specific-calibrations-for-meter-soil-moisture-sensors/> [Accessed 25/01/2021]
- Morton, D., Rowland, C., Wood, C., Meek, L., Marston, C., Smith, G., . . . Simpson, I. (2011). *Final report for LCM2007-the new UK land cover map. Countryside survey technical report no 11/07*. Lancaster, UK: NERC/Centre for Ecology & Hydrology (CEH Project Number: C03259).
- Murphy, T. R., Hanley, M. E., Ellis, J. S., & Lunt, P. H. (2020). Native woodland establishment improves soil hydrological functioning in UK upland pastoral catchments. *Land Degradation & Development*, 32(2), 1034-1045.
- Natural England. (2012). *Higher Level Stewardship. Environmental Stewardship Handbook. Fourth edition - January 2013*. UK: Natural England.
- Nicholson, A. R., O'Donnell, G. M., Wilkinson, M. E., & Quinn, P. F. (2020). The potential of runoff attenuation features as a Natural Flood Management approach. *Journal of Flood Risk Management*, 13, e12565.
- Nisbet, T. (2005). *Water use by trees*. Report number FCIN065. Surrey, UK: Forest Research.
- Nisbet, T., Roe, P., Marrington, S., Thomas, H., Broadmeadow, S., & Valatin, G. (2015). *Slowing the flow at Pickering, final report phase II for the department of environment, food and rural affairs*. Project RMP5455. Defra: London.
- Rogger, M., Agnoletti, M., Alaoui, A., Bathurst, J., Bodner, G., Borga, M., . . . Hall, J. (2017). Land-use change impacts on floods at the catchment scale—Challenges and opportunities for future research. *Water Resources Research*, 53(7), 5209-5219.

- Scotland's Soils. (2013). Scottish Soil Classification [Excel database]. Available at: <http://soils.environment.gov.scot/resources/guide-to-soil-types/> [Accessed 09/02/2018]
- Shuttleworth, E. L., Evans, M. G., Pilkington, M., Spencer, T., Walker, J., Milledge, D., & Allott, T. E. (2019). Restoration of blanket peat moorland delays stormflow from hillslopes and reduces peak discharge. *Journal of Hydrology X*, 2, 100006.
- Smith, P., Smith, J., Flynn, H., Killham, K., Rangel-Castro, I., Foereid, B., . . . Bell, J. (2007). *ECOSSE: Estimating carbon in organic soils-sequestration and emissions* (0755914988). Scottish Executive Environment and Rural Affairs Department: Edinburgh.
- Soulsby, C. (1993). Contrasting hydrological regimes in two ploughed forest soils in upland Wales. *Forestry: An International Journal of Forest Research*, 66, 153-170.
- Strosser, P., Delacámara, G., Hanus, A., Williams, H., & Jaritt, N. (2015). *A guide to support the selection, design and implementation of Natural Water Retention Measures in Europe - Capturing the multiple benefits of nature-based solutions*. Final version, April 2015, European Commission. France: European Union.
- Sun, D., Yang, H., Guan, D., Yang, M., Wu, J., Yuan, F., . . . Zhang, Y. (2018). The effects of land use change on soil infiltration capacity in China: A meta-analysis. *Science of the Total Environment*, 626, 1394-1401.
- WG POM. (2014). *EU policy document on Natural Water Retention Measures*. Technical Report-2014-082. Prepared by the drafting team of the Water Framework Directive Common Implementation Strategy Working Group Programme of measures (WG PoM). Luxembourg: Office for Official Publications of the European Communities.
- Wheater, H., & Evans, E. (2009). Land use, water management and future flood risk. *Land Use Policy*, 26, S251-S264.
- Wildlife Trust. (2020). *Bracken [online]*. Available at: <https://www.wildlifetrusts.org/wildlife-explorer/ferns-and-horsetails/bracken> [Accessed 18/05/2020]
- Wood, S., Sebastian, K., & Scherr, S. J. (2000). *Agroecosystems*. Pilot analysis of global ecosystems. Washington, DC, USA: International Food Policy Research Institute and World Resources Institute.
- World Wildlife Fund. (2016). *Natural & Nature-based Flood Management: A Green Guide*. Washington DC, USA: World Wildlife Fund.
- Zope, P., Eldho, T., & Jothiprakash, V. (2017). Hydrological impacts of land use–land cover change and detention basins on urban flood hazard: a case study of Poisar River basin, Mumbai, India. *Natural Hazards* 87(3), 1267-1283.



## Chapter 3. Seasonal vegetation and management influence overland flow velocity and roughness in upland grasslands

<sup>1</sup>Bond, S., <sup>1</sup>Kirkby, M.J., <sup>3</sup>Johnston, J., <sup>2</sup>Crowle, A. and <sup>1</sup>Holden, J.

<sup>1</sup>water@leeds, School of Geography, University of Leeds, Leeds, LS2 9JT, UK.

<sup>2</sup>Natural England, Foss House, Kings Pool, Peasholme Green, York, UK.

<sup>3</sup>Natural England, Lake District National Park Building Business Park, Murley Moss Lane, Kendal, UK.

### 3.1 Abstract

There is considerable interest in how headwater management may influence downstream flood peaks in temperate humid regions. However, there is a dearth of data on flow velocities across headwater hillslopes and limited understanding of whether surface flow velocity is influenced by seasonal changes in roughness through vegetation cycles or management. A portable hillslope flume was used to investigate overland flow velocities for four common headwater grassland habitats in northern England: Low-density Grazing, Hay Meadow, Rank Grassland and *Juncus effusus* Rush pasture. Overland flow velocity was measured in replicate plots for each habitat, in response to three applied flow rates, with the experiments repeated during five different periods of the annual grassland cycle. Mean annual overland flow velocity was significantly lower for the Rank Grassland habitat ( $0.026 \text{ m s}^{-1}$ ) followed by Low-density Grazing and Rushes ( $0.032$  and  $0.029 \text{ m s}^{-1}$ ), then Hay Meadows ( $0.041 \text{ m s}^{-1}$ ), which had the greatest mean annual velocity (examples from 12L/min flow rate). Applying our mean overland flow velocities to a theoretical 100 m hillslope suggests overland flow is delayed by >1hr on Rank Grassland when compared to Hay Meadows in an 18mm storm. Thus, grassland management is important for slowing overland flow and delaying peak flows across upland headwaters. Surface roughness was also strongly controlled by annual cycles of vegetation growth, decay, grazing and cutting. Winter overland flow velocities were significantly higher than in summer, varying between  $0.004 \text{ m s}^{-1}$  (Rushes, November) and  $0.034 \text{ m s}^{-1}$  (Rushes, June); and velocities significantly increased after cutting varying between  $0.006 \text{ m s}^{-1}$  (Hay meadows, July) and  $0.054 \text{ m s}^{-1}$  (Hay meadows, September). These results show that seasonal vegetation change should be

incorporated into flood modelling, as cycles of surface roughness in grasslands strongly modify overland flow, potentially having a large impact on downstream flood peak and timing. Our data also showed that Darcy-Weisbach roughness approximations greatly over-estimated measured flow velocities.

## **3.2 Introduction**

The frequency and intensity of flooding in many parts of the world is increasing, and climate change is a significant driver (Feyen et al., 2008; Hirabayashi et al., 2013; Middelkoop et al., 2001; Wingfield et al., 2019). However, land-use change can act as a moderator of flood risk, affecting the storage and flow connectivity of water across landscapes (Schilling et al., 2014; Wheeler and Evans, 2009). There is a lack of information, at a range of scales, about how some types of land-cover change and land-use management practices may influence downstream flood risk (Rogger et al., 2017). Despite this lack of data, a number of initiatives are now being undertaken that seek to use ‘nature-based solutions’ to flooding, including the sponge-city concept in some Chinese cities (Li et al., 2017; Liu et al., 2017), and the use of Water Sensitive Urban Design in Australia (Sharma et al., 2016). In the UK, funding has been provided to trial Natural Flood Management (NFM) initiatives which are primarily focussed on upper catchment areas that can support schemes such as woodland planting, woody debris dams, farm storage ponds, and peatland restoration (Nicholson et al., 2012; Nisbet et al., 2011; Short et al., 2019; Shuttleworth et al., 2019). Much of the UK uplands is covered by managed grasslands, both above and below the moorland line, used for sheep grazing. There have been suggestions that increased grazing intensities in UK upland grasslands may influence flood risk downstream (e.g., Meyles et al., 2006; Lane., 2001) but recent assessments of the literature have shown that there are few datasets that can demonstrate the effectiveness of grassland management or other NFM measures (Burgess-Gamble et al., 2017; Dadson et al., 2017). Therefore, it is important to collect new data. In environments where overland flow is common, vegetative surface roughness may be particularly important in slowing water flow and impacting downstream flood peak magnitude and timing.

The role of riparian roughness has been well studied for its effects on slowing channel and out-of-bank flood flows (Medeiros et al., 2012). For example, Chien (1957) measured Manning's  $n$  calculated from flood stages for different floodplain covers: for a flood between 30-60 cm depth, roughness varied from 0.05 in pasture, to 0.08 in meadows and 0.11 in 'brush and waste'. Chow (1959) produced a table containing simplistically calculated Manning's  $n$  roughness values for floodplain channels, including vegetation types ranging from pasture to trees. These values, still commonly used as an estimate for roughness (Burgess-Gamble et al., 2017; Manandhar, 2010; Phillips and Tadayon, 2006), showed riparian trees have a channel roughness of up to five times that of grassland, and grassland double that of bare earth.

While several studies have suggested surface runoff volume can be reduced by altering the vegetation cover (Macleod et al., 2013; O'Connell et al., 2007; Schafer, 1986), and such principles are used in sustainable urban drainage systems (Green, 2019), the surface roughness processes have generally not been disentangled from potential interception (Macleod et al., 2007; Marshall et al., 2009), plant uptake (Yoshikawa et al., 2004), and rooting (Bodner et al., 2014; Soulsby, 1993) storage processes. The presence and management of differing vegetation species may influence soil properties and therefore the volume of surface runoff present. Grassland management such as aeration (Wallace and Chappell, 2019), ploughing (Wallace and Chappell, 2020; Douglas and Goss, 1987), grazing (Meyles et al., 2006) and underdrainage (Burt, 2001) all influence soil permeability and moisture regime, which, in turn, partially control antecedent conditions leading up to storm events and therefore potential overland flow occurrence.

While Emmett (1970) recognised vegetation as "*an extreme influence on resistance to flow over natural hillslopes*", hillslope measurements of roughness are much less common than channel roughness measurements and have so far centred on investigating rills (Gómez and Nearing, 2005; Roels, 1984), farming processes such as ploughing (Mwendera and Feyen, 1994), and the relationship between roughness coefficients and the Reynolds number (Gilley et al., 1991; Wu et al., 1999). Surfaces studied include single-species vegetated slopes (Roels, 1984), bare soil (Gilley and Finkner, 1991), minimally vegetated desert environments (Abrahams et al., 1986; Abrahams and Parsons, 1991), (laboratory-based) agricultural crop

environments (Gilley and Kottwitz, 1994, 1995; Gilley et al., 1992) and artificial horsehair 'vegetation' environments (Wu et al., 1999). All of these studies showed that vegetation roughness is important to overland flow, although there are some types of crop cover that appear to have a minimal effect (Gilley and Kottwitz, 1994). A hillslope flume used by Holden et al. (2008), established a set of roughness parameters for *Sphagnum*, *Eriophorum*, *Sphagnum-Eriophorum* mix and bare surfaces on blanket peat. Holden et al. (2008) found that vegetation significantly influenced overland flow velocity which was 10 times faster over bare peat surfaces than for surfaces covered with a *Sphagnum* understory. Such data would be useful in other environments and for other types of vegetation cover that can be influenced by management.

Recently, slowing the flow of water across hillslopes by altering the surface roughness has been seen as a potentially important factor that could be used by land managers who seek to reduce downstream flood peaks (Gao et al., 2016, 2017; Grayson et al., 2010; Shuttleworth et al., 2019), particularly in the temperate-humid zone where saturation-excess overland flow is common (Burt, 1996). As the need for flood mitigation has increased, hydrological modelling has been used to demonstrate the potential importance of vegetative surface roughness on the timing of flood peaks from upland peatland systems (Ballard et al., 2011; Gao et al., 2016, 2017; Lane and Milledge, 2013). These studies all suggest that overland velocity and surface roughness data made from local observations could be very important when modelling downstream flood hydrographs. It is also widely agreed that there are more sensitive areas of the landscape for which surface cover change could cause the largest shifts in peak flow and timing. As such, this is important evidence that suggests spatially targeted management interventions on surface roughness could reduce downstream flood peaks as part of NFM. Thus, data is urgently needed on overland flow velocities from non-peatland areas to inform hydrological modelling.

NFM initiatives in the UK are primarily focussed on headwater areas which typically have a cool, wet climate with organo-mineral soils (58.5% of UK uplands are underlain by organo-mineral soils (Bol et al., 2011)). However, the extent of storage and flow velocity reduction is dependent on catchment characteristics including factors such as geology, antecedent conditions, vegetation type and land use. Previous surface roughness evaluations have

focussed on peatlands (Gao et al., 2016, 2017; Holden et al., 2008) and cropland (Gilley and Kottwitz, 1994), but grassland covers approximately 46% of the total UK land area (Defra, 2016) and 69% of global agricultural land (Wood et al., 2000), of which much is used for grazing. Since vegetation composition and its spatial distribution is strongly associated with grazing (Clarke et al., 2008; Davies and Bodart, 2015; Martin et al., 2013; Merriam et al., 2018), how grassland roughness varies between grazing and other land management regimes is important. In addition, altering grazing regimes is possibly more achievable for many landowners worldwide than other NFM interventions. Therefore, it is important to measure overland flow velocities and calculate roughness values from such environments and to understand how they vary with vegetation in these upland systems.

An important factor that needs to be considered in land management interventions that seek to influence surface roughness, is that of seasonality – the surface roughness and consequent retardation of overland flow may change during the year with vegetation growth cycles. However, such an effect has rarely been studied and is generally not incorporated into flood models. Nevertheless, seasonality has long been recognised as a potential factor influencing channel roughness. For example, Chien (1956) studied the effect of vegetation to drainage channel roughness and found a seasonal variation in Manning's  $n$  ranging from 0.033, when the channel was clear of vegetation, 0.055 when bushy willows grew on the side slopes, 0.115 after a thick growth of cattails on the channel bed, and 0.072 after the cattails were washed out by a storm. Where hillslope vegetation seasonality has been used within flood modelling, studies have typically focussed on woodland coverage and interception changes (De Roo et al., 2001; De Roo et al., 2003; Jackson et al., 2008) or impacts of sudden vegetation removal (such as through cutting) which Kourgialas and Karatzas (2013) suggested (based on predicted Manning's  $n$  values from Chow (1959) and Sturm (2001)), could significantly alter predicted flood area. However, no field-based hillslope roughness studies have yet investigated seasonal changes in vegetation or coupled these changes to flood risk.

This paper aims to:

- 1) Expand the range of vegetation characterised for hillslope surface roughness, particularly to grassland upland environments which are subject to land management such as grazing and cutting.
- 2) Calculate any seasonal variation in roughness to improve understanding of vegetation impacts on surface flow.
- 3) Assess the appropriateness of the Darcy-Weisbach coefficient for hillslope surface roughness measures
- 4) Provide roughness parameter values which could be used in the future to model how flood response may vary under different grassland cover types and seasons.

### 3.3 Methods

#### 3.3.1 Study site

Field measurements were conducted in the Swindale catchment, Lake District, UK (54° 30' 14.75"N, 2° 45' 56.91"W). The Lake District is a mountainous region in the northwest of England designated as a UNESCO World Heritage site. Swindale comprises a 2.66 km<sup>2</sup> U-shaped valley between 270m and 430m elevation, with upland organo-mineral soils, predominantly Malvern 611a (Chromic Endoleptic Umbrisol) and Bangor 311e (Dystric Epileptic Histosol) soils (Cranfield University, 2020). Between 1981 and 2010 mean annual precipitation was 1779 mm in the nearby village of Shap, 5km northeast of Swindale at 255m above sea level; mean of each daily maximum temperature at Shap was 11.5°C, and mean daily minimum was 4.1°C (Met Office, 2020).

Swindale is managed as a working grassland farm under a higher-level stewardship (HLS) scheme. HLS is an agri-environmental scheme in England which provides funding to land managers in return for environmentally conscious management (Natural England, 2012). This includes action such as creating and maintaining woodland, encouraging species-rich grassland or Hay Meadows, or protecting water-quality through buffer strips. Four farm-based habitats were chosen in Swindale to represent commonly occurring UK upland grassland types which have distinctive, but potentially adaptable, management strategies. These were Hay Meadows, Low-density Grazing, Rushes and Rank Grassland (Table 3.1). A full description of species presence and abundance, and the survey method used, can be found in Appendix B2.

Table 3.1: Upland grassland habitats studied in Swindale.

Habitat name	Location within Swindale	Dominant species	Average vegetation height (cm)	Description and Management
<b>Hay Meadows</b>	Valley floor on either side of the Swindale Beck (river)	Grasses: <i>Holcus lanatus</i> , <i>Anthoxanthum odoratum</i> and <i>Cynosurus cristatus</i>  Broadleaf species: <i>Rhinanthus minor</i> , <i>Trifolium dubium</i> , <i>Trifolium pratense</i> and <i>Plantago lanceolata</i> .	April: 3.4 June: 18.8 July: 35.5 Sept: 1.1 Nov: 2.2	Hay Meadows are species rich grasslands in which no single species dominates. Parts of Swindale represent a typical upland hay meadow: species rich with a SSSI <sup>†</sup> designation in parts of Swindale. Left ungrazed from March throughout the spring and summer months until cutting at the first opportunity after 25 <sup>th</sup> July. After this, the Hay Meadows are lightly grazed through the winter months while sufficient fodder remains.
<b>Low-density Grazing</b>	On the slopes immediately above the Hay Meadows	Grasses: <i>Festuca ovina</i> , <i>Agrostis spp.</i> and <i>Cynosurus cristatus</i>  Moss species: <i>Rhytidiadelphus squarrosus</i>  Broadleaf species: <i>Trifolium repens</i> , <i>Luzula campestris</i> and <i>Rumex acetosella</i> .	June: 10.6 July: 4.2 Sept: 8.9 Nov: 2.8	The definition of low-density grazing on upland pasture varies greatly. In Swindale, low-density grazing represents a maximum 2.66 ewes plus lambs per hectare, but stock density is very variable throughout the year. Most stock spend bulk of summer months out of Swindale on common land, returning for short periods for treatments, shearing and separating lambs from ewes. Stock mostly sent away for winter months.
<b>Rushes</b>	Found in large swathes throughout the catchment	Soft rushes: <i>Juncus effusus</i>	Not recorded	<i>Juncus effusus</i> rush swathes only. Most of these areas fall within areas managed as Low-density Grazing (as above) but the rushes are unpalatable and are generally avoided by grazing animals. No specific management is applied at Swindale. However, rush is commonly removed in the UK under some forms of management (Gilley et al., 1992; Pinches, 2013; Wolton, 2000)
<b>Rank Grassland</b>	Within sections of the catchment fenced-off from grazing	Grasses: <i>Dactylis glomerata</i> , <i>Holcus lanatus</i> , <i>Agrostis capillaris</i> , <i>Anthoxanthum odoratum</i> , <i>Festuca spp.</i> Broadleaf: <i>Ranunculus repens</i> , <i>Lotus pedunculatus</i> , and <i>Ranunculus acris</i>	April: 13.0 June: 31.9 July: 37.7 Sept: 10.1 Nov: 8.8	Typically species poor, Rank Grassland is dominated by tall, tussocky and coarse grass species and is produced in unmanaged, ungrazed grasslands. In Swindale, Rank Grassland is the result of grazed fields being fenced-off for a period of six years without cutting or grazing. No management currently applied in Swindale

<sup>†</sup>SSSI is a Site of Special Scientific Interest, a conservation designation in the UK which gives legal protection to land with features of particular interest such as its wildlife, geology or landforms.



### 3.3.2 Flume design

A portable and durable hillslope flume (Figure 3.1), for measuring vegetative roughness subject to overland flow, was constructed based on designs of a miniature flume for interrill overland flow by Parsons and Abrahams (1989), and a hillslope flume for vegetative roughness measurements in peatlands by Holden et al. (2008). Bounded plots measuring 0.4 m by 2.0 m were established using aluminium panels hammered into the ground.

Immediately downslope of each plot, a Z-shaped aluminium panel 0.4 m wide with three 0.2 m long faces angled at 60 ° to form a Z-shape, also bound on either side with aluminium panels, was dug into the ground so that the upper surface was level with the soil surface. To ensure a seal between the ground surface and Z-shape, the Z-shape was driven into the soil face by approx. 2cm. Onto the opposite surface-edge of the Z-shape, a plastic funnel was fitted level with the Z surface. The funnel was attached and made water-tight using tape and petroleum jelly. The funnel was designed to collect water travelling through the flume and channel it into and through a fluorometer, attached to the funnel, without disrupting water flow rate. A fluorometer was used to measure the fluorescence at the outlet after slugs of tracer were added in low concentrations at the inlet, enabling automated velocity measurements. The Z-shape, funnel and fluorometer were dug into the ground in such a way as to provide a continuity of the slope angle for the hillslope bounded plot. A Seapoint Rhodamine fluorometer was wired to a CR220X data logger and laptop, capable of recording changes in fluorescence every one second.

To provide water, a 180L portable 'bowser' water tank was positioned at the top of each flume and filled from nearby streams using pumps. Flow from the bowser was controlled using a Mariotte tube to provide a uniform flow rate. Three separate applied flow rates were investigated; 12 L/min, 6 L/min and 1.2 L/min. If applied over a 100 m slope, these flow rates reflect rainfall intensities of 18 mm hr<sup>-1</sup>, 9 mm hr<sup>-1</sup> and 1.8 mm hr<sup>-1</sup> respectively and were chosen to reflect a range of realistic rainfall intensities for storm events in the UK uplands (e.g., Holden and Burt, 2002).

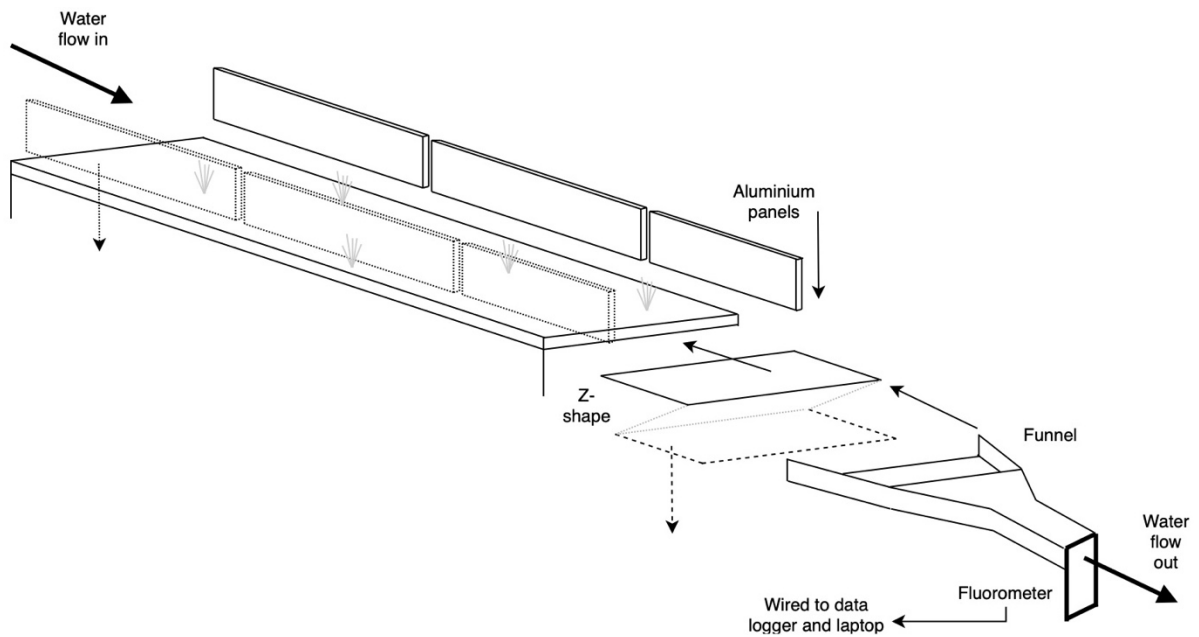

Figure 3.1: Overland flow hillslope flume design

### 3.3.3 Data collection

Sampling locations were chosen using a stratified approach based on a visual assessment of habitat representativeness and practicality of access. Data was collected over five field campaigns between April and November 2019. This time period was chosen to reflect the course of one growing season, over which the Rank Grassland and Rushes habitats were subject to natural growth and decay only, and the Low-density Grazing and Hay Meadow habitats were subject to additional management (Table 3.1). Ewes and lambs on the Low-density Grazing habitat were separated between July and September data collections, reducing grazing pressure with up to two-thirds fewer sheep grazing in the studied fields. Almost all sheep were off-wintered (transferred out of the catchment) before the November collection. For the Hay Meadow habitat, vegetation was cut between the July and September data collections. Visual habitat change over selected months throughout the growing season is shown in Figure 3.2.

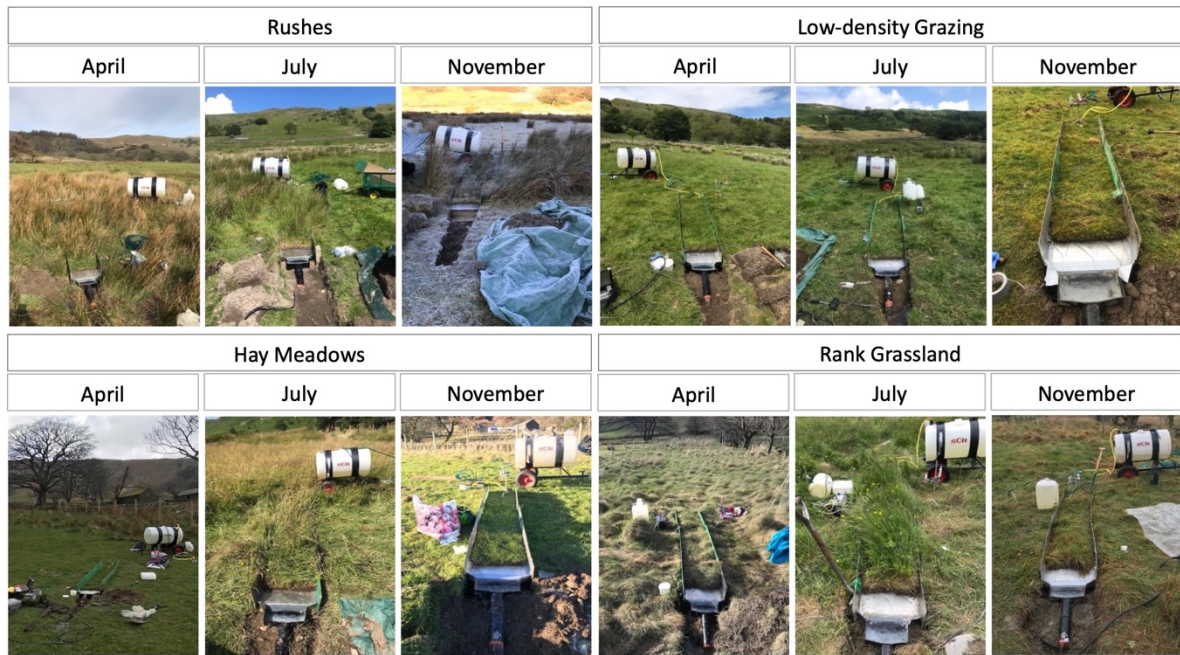

Figure 3.2: Flume set up showing visual habitat change seasonally. Average slope angles for each habitat are shown in Table 3.2.

Flumes were set-up in locations considered visually representative of the habitat type, and away from field boundaries to reduce edge effects. New locations were chosen for each flume study (i.e., the same point was not revisited during each field campaign) in order to be representative of the whole habitat and to eliminate any influence on vegetation from the flume structure. For example, it was thought that natural grazing patterns could be disturbed by in situ equipment. One flume per habitat was established for April and November data collections and, with the exception of the 1.2L/min July flow data for Rushes and Rank Grassland for which overland flow could not be generated in the dry conditions, two flumes per habitat were established in all other months. Across all field campaigns, a total of eight flumes were set-up for each of the Hay Meadow and Low-density Grazing habitats and seven flumes for each of the Rank Grassland and Rushes habitats. For each flume established, a minimum of five Rhodamine injections were recorded for each flow rate.

Vegetative surface roughness was measured using Rhodamine WT dye at a concentration detectable for all three flow rates. The flume concentration range observed and fluorometer breakthrough curves are discussed in Appendix B3. The length of vegetation

over which flow occurred varied per flume depending on habitat and conditions. Most often, flume length measured approximately 2m for the 12 L/min and 6 L/min flow rates, and approx. 1.1m for the 1.2 L/min flow rate. This shorter flume length was chosen for the lowest flow rate due to the long time period required to saturate the ground at that flow rate. Similar flume lengths between locations and across seasons ensured habitat comparability.

### 3.3.4 Calculating surface roughness

Downslope flow velocity was used as a proxy measurement for vegetative surface roughness, where recorded velocity varied as the result of friction between the vegetation and overland flow. Mean velocity,  $\bar{V}$ , was calculated using an inverse time method, where:

$$\bar{V} = \frac{\sum_{i=1}^n \frac{l}{t_i V q_i}}{\sum_{i=1}^n \frac{1}{V q_i}} \quad (3.1)$$

and:

$$V q_i^n = SEV o l t_i - LoQ \quad (3.2)$$

where  $l$  is the vegetated flume length (m);  $t$  is the time difference in seconds from the point of Rhodamine injection; and  $Vq$  is the SEV o l t above limit of quantification ( $LoQ$ ).

Fluorescence was measured in SEVolts. Further information about these calculations, including examples of breakthrough curves, can be found in the Appendices B1 and B2.

Darcy Weisbach roughness,  $f$ , was calculated as a commonly used measure of roughness:

$$f = \left( \frac{8g\bar{d}S}{\bar{V}^2} \right) \quad (3.3)$$

and

$$\bar{d} = \frac{Q}{w\bar{V}} \quad (3.4)$$

where  $g$  is the gravitational acceleration constant,  $\bar{d}$  is mean flow depth (m),  $S$  is the slope ( $\alpha$ ),  $\bar{V}$  is the mean velocity ( $\text{m s}^{-1}$ ),  $Q$  is the flow rate ( $\text{m}^3 \text{s}^{-1}$ ), and  $w$  is the flume width (m).

Mean flow depth was calculated based on the Rhodamine response curve, flume dimensions and fixed flow rate. Given this, the Rhodamine response curve could not be used to calculate a lower-flume flow rate. Therefore, flow rate was assumed to be equal at the top of the flume as at the bottom, where saturation, once reached, sufficiently impedes water percolation so that infiltration losses compared to overland flow rates are negligible. Instrumentation to accurately measure flow rate at the bottom of the flume was too bulky for a portable flume, and, over two metres, a saturation assumption was considered reasonable.

### 3.3.5 Modelling expected roughness

Traditionally, roughness has been calculated using either Manning's  $n$  or Darcy-Weisbach roughness ( $f$ ) coefficients. While both of these methods are valid forms of measuring roughness within channel contexts, there is debate about whether they are transferable to hillslope environments.  $f$  has been applied in both laminar and turbulent flow regimes, while  $n$  is most relevant in turbulent flows where roughness elements are very fully submerged by the flowing water. However, since both roughness coefficients are commonly used in catchment-scale hydrological modelling, it is essential that field roughness observations are suitably transferrable to modelling scenarios. Both  $f$  and  $n$  coefficients generally make the assumption that the measured roughness elements are comparable to grains on a riverbed. This differs from most overland flow scenarios, for which vegetation stems are only partially submerged and may be subject to flow forces which drag them downwards. To test the appropriateness of roughness measurements in vegetated hillslope contexts, the properties of flow were investigated with respect to expected roughness. The Darcy-Weisbach equation describes resistance to flow (equation 3.3) which can also be related, for fully turbulent flow, to the ratio of flow depth,  $d$ , to equivalent grain roughness,  $k$ :

$$f^{-0.5} = A + B \log_{10}\left(\frac{d}{k}\right) \quad (3.5)$$

where  $A$  and  $B$  are empirically derived constants. Equation (3.5) implies that as the ratio of depth to roughness ( $d/k$ ) increases, so the Darcy-Weisbach friction factor,  $f$ , should decrease ( $f^{0.5}$  increase), as long as  $k$  remains roughly constant. In order to investigate the expected relationship between discharge and velocity for a fixed  $k$ , a Constant Grain Roughness Model was produced as described below.

Using regularly spaced  $f$  values  $0.01 < f < 1000$ , depth,  $d$ , was calculated from equation (3.5). Following this, velocity was calculated using equation (3.6), rearranged from equation (3.3), and discharge ( $\text{m}^3 \text{s}^{-1}$ ) from equation (3.7):

$$V = \sqrt{\frac{8gdS}{f}} \quad (3.6)$$

$$d = \frac{Q}{wV} \quad (3.7)$$

This model assumed fixed slope,  $S$ ; width,  $w$ ;  $A$  and  $B$  constants (Myers, 2002); and a fixed equivalent grain roughness where  $S = 0.17$ ,  $w = 0.40$ ,  $A = 1.14$ ,  $B = 2.00$  and  $k = 0.01$  and  $0.001$ . The Reynolds number,  $Re$ , was calculated for each iteration:

$$Re = \frac{Vd}{\nu} = \frac{Q}{w\nu} \quad (3.8)$$

where  $\nu$  is the kinematic viscosity,  $1.307 \times 10^{-6} \text{ m}^2 \text{ s}^{-1}$  at  $10^\circ \text{C}$ . Fully turbulent flow was assumed where  $Re > 2000$ , and laminar flow where  $Re < 500$ .

For laminar flow conditions, equation (3.5) no longer applies, and the friction factor is related to the Reynolds number by the relationship (3.9):

$$f = \frac{64}{Re} \quad (3.9)$$

Following modelling using the Constant Grain Roughness Model, Relative Roughness,  $k^*$ , was calculated to investigate the relationship between  $k^*$  and seasonality using calculated  $V$  and applied  $Q$  values from field data collection. If:

$$V = \frac{8gd^2S}{k^*v} \quad (3.10)$$

then, using equation (3.7):

$$V = [8gSQ^2/(k^*vw^2)]^{1/3} \quad (3.11)$$

and

$$k^* = \frac{48Q^2}{V^3} \quad (3.12)$$

for the experimental flume width and gradient at 10°C.

Using the Darcy-Weisbach equation form for wide channels (equation (3.10), Myers (2002)),  $k^*$  was calculated for each habitat using equation (3.12).

### 3.4 Results

Surface cover exerts a strong influence over overland flow. A Kruskal-Wallis test showed significant differences in mean flow velocity between all habitats ( $p < 0.05$ ) except between Low-density Grazing and Rushes. Mean overland flow velocity across all times of the year (hereafter 'mean annual overland flow velocity') was consistently lowest for the Rank Grassland habitat, followed by Low-density Grazing and Rushes habitats, then Hay Meadows, which had the highest mean velocity (Table 3.2). In response to the same applied flow event, overland flow velocity for the Hay Meadows habitat was up to double that recorded for Rank Grassland (Table 3.2, Figure 3.3). Slope was dissimilar between all habitats except Low-density Grazing and Rushes. However, there was no correlation between velocity and slope. Hay Meadows, with the shallowest slopes, produced the fastest velocities. Therefore, slope was not a significant influence over velocity for the habitats studied.

Table 3.2: Count, velocity, flow depth, Darcy-Weisbach roughness, slope, and relative roughness summary table for all flume data. Count represents the number of Rhodamine injections, therefore data points per habitat. Habitats are represented by abbreviation where RG is Rank Grassland, LDG is Low-density Grazing, H is Hay Meadows, and R is Rushes. For velocity, flow depth, Darcy-Weisbach roughness and relative roughness, the mean ( $\mu$ ) and standard deviation ( $\sigma$ ) of the data is given. For Slope, the mean ( $\mu$ ) slope in radians is shown.

Habitat type	Count, n	Velocity, $V$ ( $m\ s^{-1}$ )		Flow depth, $d$ (m)		Darcy-Weisbach roughness, $1/\sqrt{f}$		Slope (rad)	Relative roughness, $k^*$	
		$\mu$	$\sigma$	$\mu$	$\sigma$	$\mu$	$\sigma$	$\mu$	$\mu$	$\sigma$
<b>1.2 L/min</b>										
RG	23	0.00506	0.000817	0.0108	0.00182	0.0129	0.00303	0.19	7.48	1.26
R	31	0.00674	0.00291	0.00916	0.00335	0.0216	0.0124	0.17	6.34	2.32
LDG	41	0.00589	0.00149	0.00975	0.00299	0.0180	0.00751	0.17	6.75	2.07
H	35	0.00851	0.00237	0.00669	0.00187	0.0345	0.0136	0.13	4.69	1.32
<b>6 L/min</b>										
RG	42	0.0170	0.00488	0.0179	0.00472	0.0355	0.0143	0.19	7.10	1.87
R	32	0.0223	0.00753	0.0143	0.00503	0.0558	0.0238	0.17	5.60	2.02
LDG	41	0.0209	0.00360	0.0140	0.00230	0.0514	0.0175	0.17	5.54	0.91
H	43	0.0271	0.00550	0.0111	0.00289	0.0820	0.0228	0.13	4.39	1.15
<b>12 L/min</b>										
RG	52	0.0257	0.00590	0.0227	0.00712	0.0471	0.0154	0.19	7.23	2.27
R	38	0.0320	0.0100	0.0188	0.00593	0.0696	0.0277	0.17	5.98	1.89
LDG	44	0.0289	0.00581	0.0200	0.00669	0.0608	0.0232	0.17	6.37	2.14
H	43	0.0414	0.00891	0.0141	0.00503	0.113	0.0334	0.13	4.55	1.63



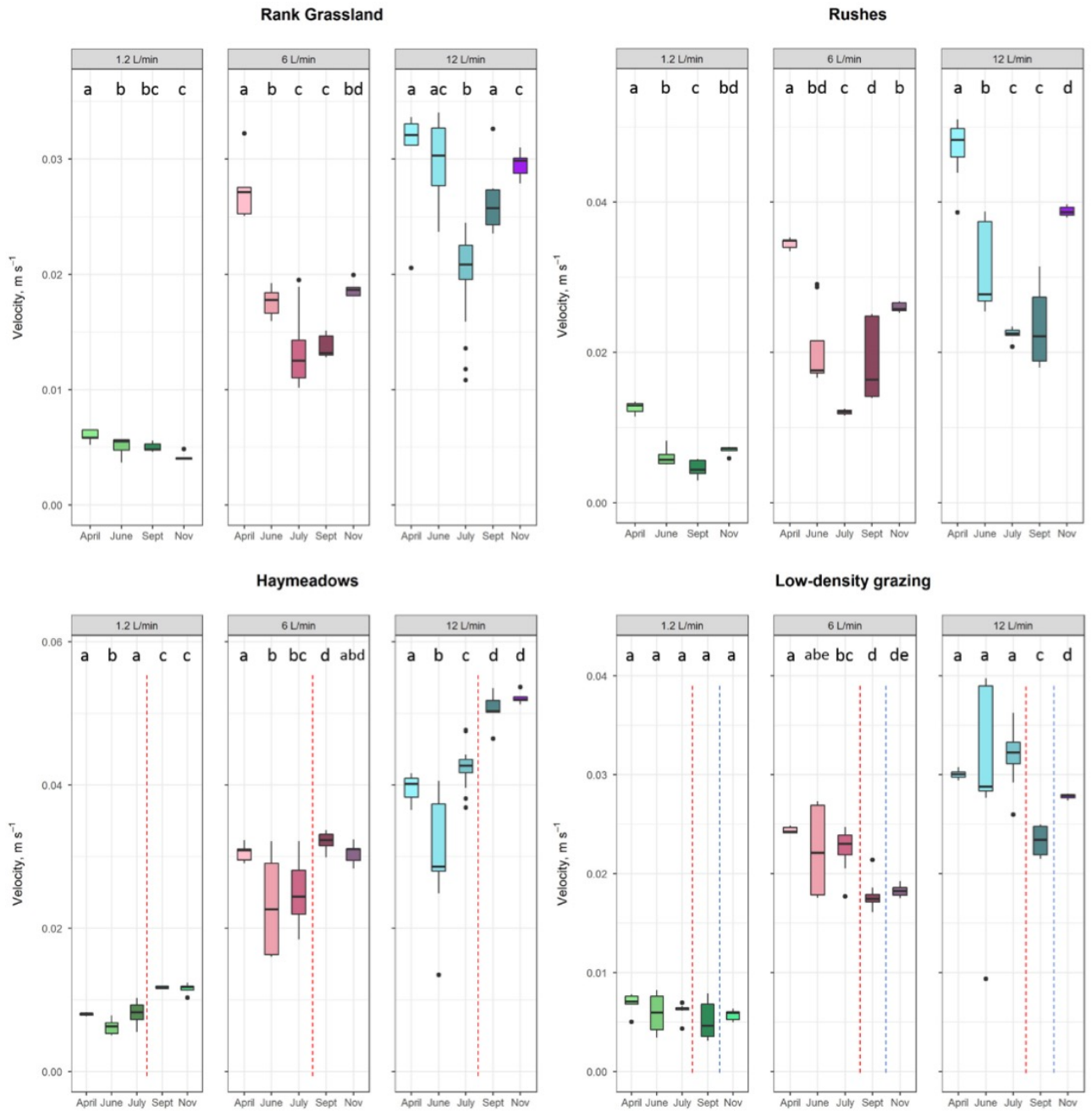

Figure 3.3: Seasonal overland flow velocity for Rank Grassland, Rushes, Hay Meadows and Low-density Grazing. Boxplots show the range, quartiles and median data for each sampling period and flow rate for each habitat. Statistical significance is shown by the letters above each graph facet (Dunn's post-hoc test,  $p < 0.05$ ) where comparisons are made between months within each facet, and a shared letter indicates no statistical significance. Dotted lines represent management interventions occurring. Hay Meadows: green dotted lines indicate cutting between July and September data collections. Low-density Grazing: red dotted line indicates separation of lambs from ewes between July and September data collection; blue dotted lines indicate off-wintering of sheep, occurring in October before final data collection.

Within each habitat, the seasonal pattern of growth, decay and management is visible, shown by the striking 'U-shaped' nature of the 6L/min and 12L/min response curves for individual habitat types (Figure 3.3). The U-shaped pattern appears to represent an annual cycle for which there are low velocities during the summer months and higher velocities during spring and autumn. Although mean annual flow velocity had a clear habitat 'roughness order' (Table 3.2), Rank Grassland did not always have the lowest flow velocity. During April and November, for all flow rates except the 1.2L/min in November, Low-density Grazing velocity was equal to, or had a significantly lower recorded overland flow velocity, than the Rank Grassland habitat (Dunn's post-hoc,  $p < 0.05$ , Figure 3.3). In comparison, for the 6L/min and 12L/min flow rates during June, July and September, Rank Grassland and Rushes habitats had the joint lowest flow velocity, with the exception of 6L/min September for which Rank Grassland had the lower velocity (Figure 3.3, Table 3.2).

Seasonal roughness change in managed habitats was strongly centred on management events (Figure 3.3). Whereas Rank Grassland and Rushes habitats demonstrated a U-shaped roughness curve which increased and then diminished through the growing season, the managed habitats exhibited a clear response to interventions. The Hay Meadows were cut between the July and September data collections, between which there was a significant increase in mean overland flow velocity for all three flow rates (Dunn's post-hoc,  $p < 0.05$ ); 43.7% increase in mean flow velocity for the 1.2 L/min applied flow rate, 28.4% increase for the 6L/min flow rate, and 19.1% increase for 12L/min flow rate (Figure 3.3).

In comparison, the mean flow velocity for Low-density Grazing decreased significantly in response to reduced grazing pressures (Dunn's post-hoc,  $p < 0.05$ ); between July and September data collections, flow velocity decreased by 20.9% for the 6L/min applied flow rate and 26.6% for the 12L/min rate (Figure 3.3). In response to a second reduction in grazing pressure between September and November, a time of year in which vegetation dieback also occurs, no statistical change in flow velocity was recorded for the 6L/min flow rate; however, a significant increase in flow velocity of 18.8% was recorded for the 12L/min flow rate (Figure 3.3).

Flow velocity was greatest in response to the highest applied flow rate, which also produced the most varied velocity between habitats. For the 12 L/min applied flow rate, recorded velocity for all habitats varied by  $0.45 \text{ m s}^{-1}$  across the growing season, in comparison to  $0.025 \text{ m s}^{-1}$  for the 6 L/min flow rate, and just  $0.0082 \text{ m s}^{-1}$  for the 1.2 L/min rate (Figure 3.3, Table 3.2). This strongly suggests that vegetative roughness exerts a higher influence on overland flow velocity during larger storm events than smaller events. In comparison to higher flows, seasonal differences in velocities in response to 1.2 L/min flows were more muted. This is most clearly demonstrated by the flow velocity response in the Low-density Grazing habitat, within which there were no significant seasonal differences for the 1.2 L/min flow rate (Figure 3.3).

Mean flow depth was calculated using equation (3.4) and across all applied flow rates and habitats ranged between 0.004m and 0.058m with a mean of 0.015m. Depth was consistently greatest for the Rank Grassland vegetation across all applied flow rates, and shallowest for the Hay Meadows habitat. Low-density Grassland and Rushes habitats had very similar mean flow depths (Table 3.2). As with velocity, depth also varied seasonally, increasing into the summer months for all habitats, and decreasing towards winter.

Produced from outputs of the Constant Grain Roughness Model (equations 3.5-3.9), Figure 3.4 shows discharge against velocity for both turbulent ( $k=0.001$  and  $k=0.01$ ) and laminar flows, plotted beside calculated Swindale data, which is categorised as laminar. As expected, the modelled  $V$ - $Q$  relationship has a slope of 0.67, for which the Swindale data best fit line is almost parallel; however, Swindale data show a velocity approximately ten times less than modelled for a laminar flow. This is thought to be primarily due to the increased roughness from vegetated surfaces which behave differently to the grain-bed river channels, for which Darcy-Weisbach roughness is most appropriate. The influence of  $k$  on flow velocity is shown by the varying  $k$  inputs for turbulent flow.

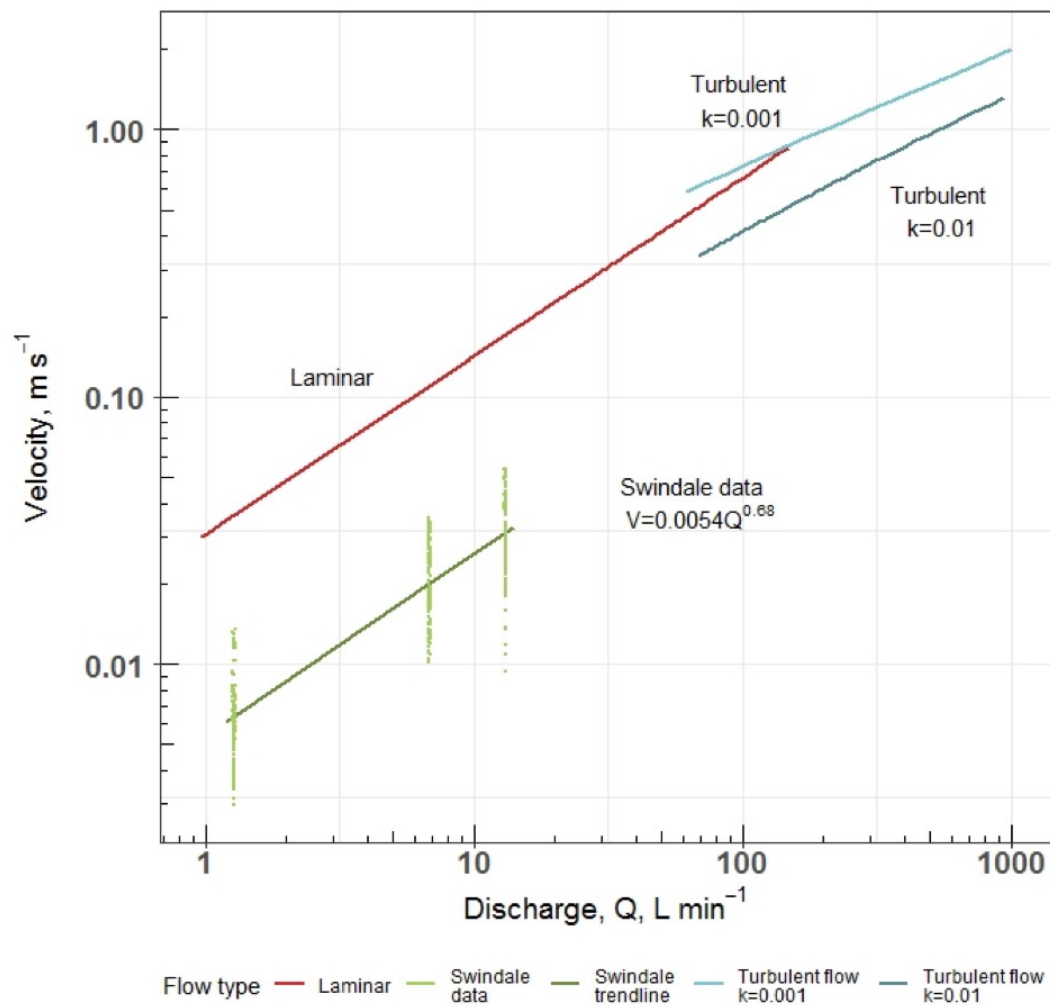

Figure 3.4: The relationship between discharge and velocity, comparing theoretical to calculated Swindale values

Annually,  $k^*$  is similar between flow rates (Table 3.2). However, Figure 3.5 shows how  $k^*$  changes between April and November, reflecting seasonal changes in growth and management of grasslands as discussed previously. The change in  $k^*$  seasonality also shows the importance of relative roughness between habitats and calls into question the appropriateness of the Darcy-Weisbach  $f$  as a measure of roughness within which  $k$  should remain constant with increasing depth.

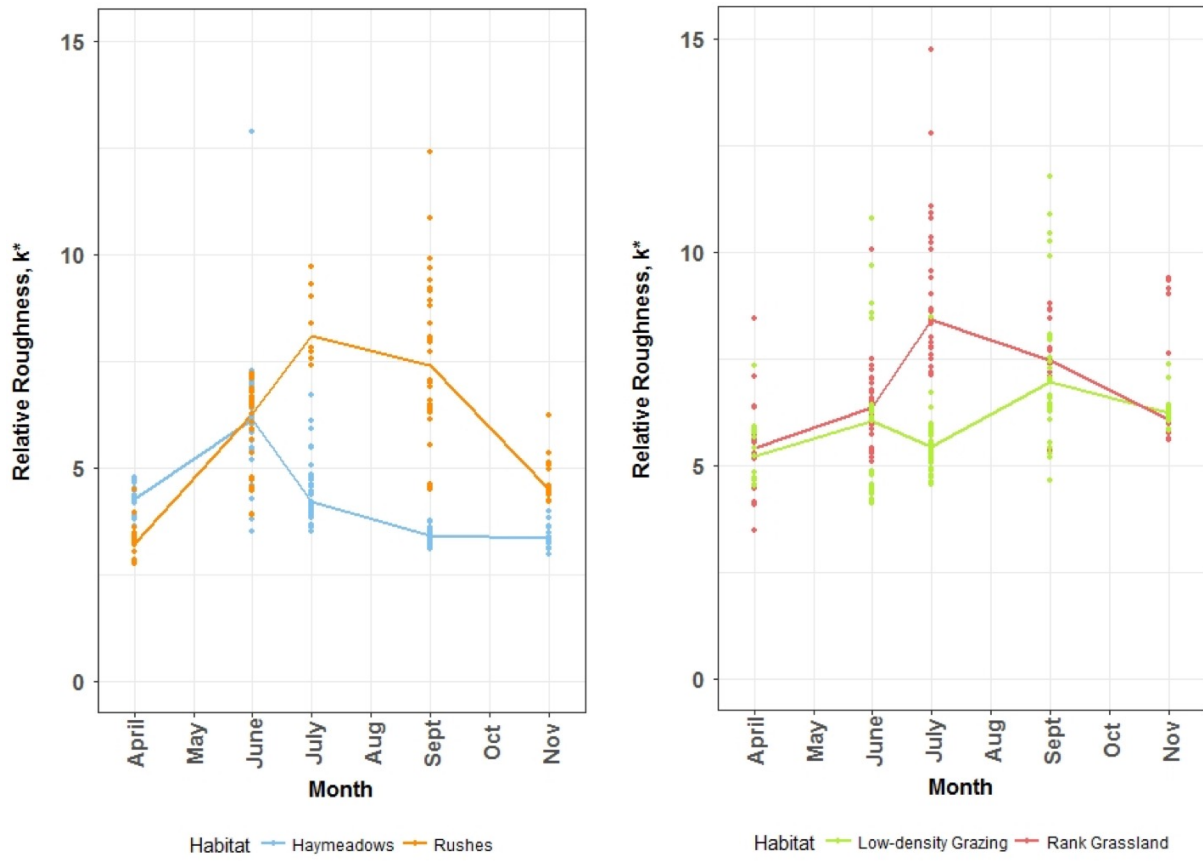

Figure 3.5: Calculated relative roughness ( $k^*$  in equation 3.12), showing seasonality for Swindale

## 3.5 Discussion

### 3.5.1 Impact of grassland type on overland flow velocity

We found striking differences in overland flow velocity between grassland habitats within the same catchment, showing that the condition of the grassland can strongly influence overland flow and its associated roughness. Rank Grassland was shown to have the most influence in slowing overland flow across the year, followed by Low-density Grazing, Rushes and Hay Meadows (Table 3.2). These velocity differences have potentially large implications for flood management in upland farming systems. The strong difference in overland flow velocity provides empirical evidence which supports the use of grassland manipulation as a NFM method for 'slowing the flow'. In the UK, rainfall is often frontal with low intensities maintained over several hours leading to saturation-excess overland flow. Frontal or convective storms with rainfall intensities over  $12 \text{ mm hr}^{-1}$  for short durations are relatively rare, typically occurring in the uplands  $\sim 10$  times per year for a few minutes in duration (e.g., Holden and Burt (2002)). If theoretically applied over a continuous 100 m hillslope, the difference in roughness we found is such that, for a 12L/min applied flow rate (equivalent to an  $18 \text{ mm hr}^{-1}$  rainfall event), the mean time for flow to reach the bottom of the slope ranges between 40 minutes for the Hay Meadows habitat in comparison to 64 minutes for the Rank Grassland habitat. For the 1.2L/min flow rate ( $1.8 \text{ mm hr}^{-1}$  rainfall event) this delay is even larger; over a 100 m slope, overland flow in the Rank Grassland may take 5 hours 29 minutes to reach the bottom in comparison to 3 hours 15 minutes in the Hay Meadows habitat. However, to understand the influence of such roughness variation on flow peak arrival and delay under different grassland habitats during storm events requires hydrological modelling.

### 3.5.2 Seasonal influences on overland flow

The seasonal impact of vegetation within habitat types was clearly visible from the 'U-shaped' mean velocity response curves. This is doubtless a strong reflection of the growth and decay of vegetation within those habitats throughout the year where flow velocity decreases with vegetation growth and increases with decay. Results suggest that Low-density Grazing may be more effective than Rank Grassland in reducing flow velocity over winter months (represented by April and November); and Rank Grassland and Rushes were

more effective during summer months. This shows that seasonality of vegetation is important in controlling overland flow velocity, and therefore must be related to both vegetation species and to vegetation management; most important is the portion of vegetation in direct contact with overland flow, which for this study was between 0 and 6 cm above the surface.

The vegetation species present on the Low-density Grazing areas included common grasses such as *Festuca ovina* and *Agrostis spp.* underlain by *Rhytidiadelphus squarrosus* moss throughout, and broadleaf species such as *Trifolium repens*, *Luzula campestris* and *Rumex acetosella*. Due to grazing, these species remain close to ground level. The mossy understorey in particular has a coarse structure with a broad-leaf base, which is evergreen, maintaining structure throughout the year. In the flume investigations by Holden et al. (2008) and subsequent modelling by Gao et al. (2017), *Sphagnum* mosses were shown to have a significant influence on downslope velocity, reducing modelled downstream flood peak by up to 15% compared to a baseline unrestored peat catchment which included some areas of bare peat and grazing. Although the vegetation within the Low-density Grazing habitat remained short, the presence of *Rhytidiadelphus squarrosus* moss may be the reason for such high roughness during winter months.

Rank Grassland and Rushes habitats, whilst both equally 'rough' through the summer months, probably have very different methods of detaining overland flow. Rank Grassland contained grass species such as *Dactylis glomerata*, *Holcus lanatus*, *Agrostis capillaris*, *Anthoxanthum odoratum*, *Festuca spp.*, and broadleaf species such as *Ranunculus repens*, *Lotus pedunculatus*, and *Ranunculus acris*. Together these species are thickly stemmed and dense at the base, forming clumps and root-mats. They are also able to grow tall, 'folding over' in the height of summer, whereas in winter leaf litter dominates the Rank Grassland habitat. The strong seasonal growth and decay likely alters the structure of the flow-influencing vegetation portion, therefore explaining the increase in measured overland flow velocity during the winter months. In comparison, *Juncus effuses* rushes are clumped together in dense swathes which force water to flow around the base of each plant; this can also cause pools to form in depressions between clumps. It is therefore likely that overland flow velocity in Rushes is decreased through storage and re-routing of water, as opposed to

a direct consequence of friction with the vegetation itself. The Hay Meadows, which are species rich, had a lesser effect on overland flow velocity than the other habitats. Although Hay Meadows had more species, and the species present were tall, growing up to 35.5 cm in July, and the species tended to have thinner basal stems and did not 'fold over'. Visually, basal vegetation here was also much less dense, and this likely influenced the portion of vegetation which impacted upon overland flow.

Grassland management interventions were shown to have strong effects on overland flow velocity. For the Hay Meadows habitat, there was a significantly greater velocity in September compared to July (Figure 3.3). This is highly likely to be a direct response to hay cutting after which vegetation was set back to almost bare soil in many places, with a very sparse covering of green shoots up to 1.1 cm height. Compaction of the soil from farm vehicles may also influence the roughness of the underlying soil, although flume locations were established away from visible track marks. Changes away from agricultural systems that involve cutting vegetation (for hay or silage) toward those that retain greater vegetation density could therefore result in significant improvements to summer overland flow resistance. However, where hay cutting has long been established, the cutting and post-cut grazing of the Hay Meadow environment helps to maintain the high species diversity found in this ecosystem (Jefferson, 2005). Hay and silage are also important crops required to feed livestock in the winter. An alternative to wholesale change from hay or silage to extensive pastures would be to manage vegetation conditions through field-rotation, reducing the impact of grazing on specific parts of the catchment. With reduction in summer grazing pressure, we found a decrease in flow velocity between management stages; in winter, changes to grazing pressure had a lesser effect, likely due to vegetation dieback.

While Rushes and Rank Grassland habitat were 'non-managed' habitats, their presence and, for Rank Grassland, position in the catchment can be managed. Rushes typically occur in poorly drained soils and are frequently removed in uplands to improve grassland grazing quality and, in some cases, aid soil drainage (Wolton, 2000). Therefore, whilst Rushes have a high roughness which was shown to slow overland flow in this study, the effect of their removal on overland flow, and its occurrence in the first instance, is likely to be dependent



on factors such as soil permeability and surrounding-habitat roughness. This demonstrates the importance of whole-environment considerations when implementing NFM strategies.

Six years prior to this study, Rank Grassland habitat was created in Swindale through the introduction of buffer zones which fenced-off sections of the Low-density Grazing habitat in order to improve water quality. This management intervention, in addition to its original purpose, has also significantly altered the roughness of the vegetation, thus contributing to overland flow management. This demonstrates how NFM can be used to generate whole-ecosystem benefits (Wingfield et al., 2019).

Whereas vegetation species and management are essential in controlling the height and density of vegetation, the ultimate impact of vegetative roughness is also dependent on the applied flow rate. Flow velocity and depth were found to vary most with the highest applied flow rate, 12L/min, and least with the lowest rate, where depth and velocity are the combined outcome of applied flow rate, and roughness provides friction to overland flow. This variation shows that larger storm events are more influenced by vegetative roughness, and this is likely to be related to the structure and height of the hillslope vegetation which determines roughness extent. At the lowest flow rate, 1.2L/min, for which the maximum depth was 0.018m, recorded flow velocity varied by only  $0.0082 \text{ m s}^{-1}$  between habitats (Table 3.2). This suggests that the vegetation characteristics which control overland flow velocity are more similar at this flow depth/vegetation height. In comparison, the highest applied flow rate, 12 L/min, had a maximum depth of 0.058 m and mean flow velocity varied by  $0.45 \text{ m s}^{-1}$ . Since higher flow rates have greater flow depth and therefore more contact with the taller portion of vegetation present, they are subject to a relatively greater variation in vegetation roughness, density, and possible flow pathways.

### 3.5.3 Implications for modelling and NFM

It is widely known that roughness influences overland flow velocity and that vegetation characteristics change over the course of the year (Chien, 1956; Medeiros et al., 2012). Our study clearly demonstrates that headwater grassland vegetation, and its associated roughness, is intrinsically linked to seasonal cycles and management. Consequently,

seasonal influences to vegetation may be essential for understanding the benefits and impacts of NFM initiatives. In upland temperate regions, flood events generally occur during winter months when the ground is more liable to saturation, and in summer months when ground is dry but there is increased rainfall intensity (Burt and Ferranti, 2012). Therefore, vegetation types and management chosen to reduce flood risk should be those with most influence during high-risk periods. This may include temporally driven management, or spatially driven management, both of which can be explored with modelling using the calculated  $f$  coefficient values, for the four grassland habitats studied. Indeed, spatially distributed modelling such as that by Hankin et al. (2019), who modelled the Swindale catchment using predicted roughness values, might be refined further by applying the roughness parameter values presented in this paper. For example, for a slope with a proportion  $p$  of roughness  $k_p^*$  and the rest ( $q = 1-p$ ) of roughness  $k_q^*$ , the combined average roughness, from equation (3.12) is  $k^* = (p.k_p^{*1/3} + q.k_q^{*1/3})^3$ . Thus, for example, for a slope which is 20% of roughness  $k^* = 1000$  and 80% of roughness  $k^* = 1$ , the combined average roughness  $k^* = (0.2 \times 10 + 0.8 \times 1)^{1/3} = 22$ . This indicates the importance of rough buffer strips in slowing the flow.

With our field data which specifically measured vegetative roughness, we recommend modelling now be undertaken to upscale our results to examine the influence on downstream flood peaks and to incorporate seasonal vegetation change. The location and scale of intervention can be modelled to investigate the best placement of NFM interventions. Studies such as that by Gao et al. (2016) and Blanc et al. (2012) demonstrated that the location of NFM may be as vital to reducing flood risk as the type of intervention.

We used flow velocity as a proxy for surface roughness where it is assumed that changes in vegetation characteristics, especially vegetation density, are the primary cause of flow velocity response. Despite strong seasonal relationships between habitat type, management, and overland flow depth and velocity, the portion of the vegetation which impacts overland flow (approx. 0-6cm) is difficult to survey. Therefore, although roughness is theoretically a good proxy for vegetation density, further research is required to understand any quantitative relationship. This may also determine whether roughness could be approximated by empirical measures of vegetation.

### **3.6 Conclusions**

Overland flow velocity was found to significantly vary between the four upland grassland types studied, showing that differences in surface roughness across one type of landscape can be very important in modifying flows. Rank Grassland was associated with the lowest overland flow velocities while overland flow across Hay Meadows occurred at up to twice that in Rank Grassland. Within each habitat, recorded flow velocity also varied seasonally with vegetation growth and as a result of grazing and cutting management. Our results suggest that upland grassland management and the types of grassland that managers decide to adopt in headwater systems may be crucial for flood management due to the large differences in overland flow velocity we observed. The effects of grassland cover on downstream flood risk may also be seasonally dependent and such seasonal effects need to be incorporated into future spatially distributed flood models. Until better methods of quickly surveying near-surface vegetation roughness are devised, these models should be driven by empirical velocity data where possible.

### 3.7 References

- Abrahams, A. D., Parsons, A. J., & Luk, S-H. (1986). Resistance to overland flow on desert hillslopes. *Journal of Hydrology*, 88(3-4), 343-363.
- Abrahams, A. D., & Parsons, A. J. (1991). Resistance to overland flow on desert pavement and its implications for sediment transport modeling. *Water Resources Research*, 27(8), 1827-1836.
- Ballard, C., McIntyre, N., Wheeler, H., Holden, J., & Wallage, Z. (2011). Hydrological modelling of drained blanket peatland. *Journal of Hydrology*, 407(1-4), 81-93.
- Blanc, J., Wright, G., & Arthur, S. (2012). Natural Flood Management knowledge system: Part 2 – The effect of NFM features on the desynchronising of flood peaks at a catchment scale. *CREW report*. Edinburgh: Centre of Expertise for Waters.
- Bodner, G., Leitner, D., & Kaul, H-P. (2014). Coarse and fine root plants affect pore size distributions differently. *Plant and soil*, 380(1-2), 133-151.
- Bol, R., Blackwell, M., Emmett, B., Reynolds, B., Hall, J., Bhogal, A., & Ritz, K. (2011). *Assessment of the response of organo-mineral soils to change in management practices*. Sub-Project ii of Defra Project SP1106: Soil carbon: studies to explore greenhouse gas emissions and mitigation. DEFRA
- Burgess-Gamble, L., Ngai, R., Wilkinson, M., Nisbet, T., Pontee, N., Harvey, R., . . . Maslen, S. (2017). *Working with Natural Processes–Evidence Directory*. Environmental Agency, Report No. SC150005
- Burt, T., & Ferranti, E. (2012). Changing patterns of heavy rainfall in upland areas: a case study from northern England. *International Journal of Climatology*, 32(4), 518-532.
- Burt, T. (2001). Integrated management of sensitive catchment systems. *Catena*, 42(2-4), 275-290.
- Burt, T. P. (1996). The hydrology of headwater catchments. In Petts, G. E. & Calow, P. (eds.), *River flows and channel forms* (pp. 6-31). Oxford: Blackwell Science.
- Chien, N. (1956). The present status of research on sediment transport. *Transactions, American Society of Civil Engineers*, 121, 833-868.
- Chien, N. (1957). A concept of regime theory. *Transactions, American Society of Civil Engineers*, 122, 785-793.
- Chow, V. T. (1959). Open-channel hydraulics. In *Open-channel hydraulics*. McGraw-Hill.
- Clarke, M., Creamer, R., Deeks, L., Gowing, D., Holman, I., Jones, R., . . . Ritz, K. (2008). *Scoping study to assess soil compaction affecting upland and lowland grassland in England and Wales*. Final project (BD2304) report to Defra. London: DEFRA.
- Cranfield University. (2020). The Soils Guide [online]. Available at: [www.landis.org.uk](http://www.landis.org.uk) [Accessed 27/02/2020]
- Dadson, S. J., Hall, J. W., Murgatroyd, A., Acreman, M., Bates, P., Beven, K., . . . Lane, S. N. (2017). A restatement of the natural science evidence concerning catchment-based ‘natural’ flood management in the UK. *Proceedings of the Royal Society A*, 473(2199).
- Davies, G. M., & Bodart, J. (2015). Changes in vegetation diversity and composition following livestock removal along an upland elevational gradient. *Iforest-Biogeosciences and Forestry*, 8(5), 582.
- De Roo, A., Odijk, M., Schmuck, G., Koster, E., & Lucieer, A. (2001). Assessing the effects of land use changes on floods in the Meuse and Oder catchment. *Physics and Chemistry of the Earth, Part B: Hydrology, Oceans and Atmosphere*, 26(7-8), 593-599.

- De Roo, A., Schmuck, G., Perdigao, V., & Thielen, J. (2003). The influence of historic land use changes and future planned land use scenarios on floods in the Oder catchment. *Physics and Chemistry of the Earth, Parts A/B/C*, 28(33-36), 1291-1300.
- Defra. (2016). *Key results by UK country: 1866 to 2016 [online]*. London: DEFRA. Available at: <https://www.gov.uk/government/statistical-data-sets/structure-of-the-agricultural-industry-in-england-and-the-uk-at-june>. [Accessed 27/02/2020]
- Douglas, J., & Goss, M. (1987). Modification of pore space by tillage in two stagnogley soils with contrasting management histories. *Soil and Tillage Research*, 10(4), 303-317.
- Emmett, W. W. (1970). *The hydraulics of overland flow on hillslopes* (Vol. 662). USA: US Government Printing Office.
- Feyen, L., Barredo, J., & Dankers, R. (2008). Implications of global warming and urban land use change on flooding in Europe. In Feyen, J., Shannon, K. & Neville, M. (eds.), *Water and Urban Development Paradigms: Towards an integration of engineering, design management approaches* (pp. 217-225). London: Taylor and Francis Group.
- Gao, J., Holden, J., & Kirkby, M. (2016). The impact of land-cover change on flood peaks in peatland basins. *Water Resources Research*, 52(5), 3477-3492.
- Gao, J., Holden, J., & Kirkby, M. (2017). Modelling impacts of agricultural practice on flood peaks in upland catchments: An application of the distributed TOPMODEL. *Hydrological Processes*, 31(23), 4206-4216.
- Gilley, J. E., & Finkner, S. C. (1991). Hydraulic roughness coefficients as affected by random roughness. *Biological Systems Engineering: Papers and Publications*, 122.
- Gilley, J. E., & Kottwitz, E. (1994). Darcy-Weisbach roughness coefficients for selected crops. *Transactions of the ASAE*, 37(2), 467-471.
- Gilley, J. E., & Kottwitz, E. R. (1995). Darcy-Weisbach roughness coefficients for surfaces with residue and gravel cover. *Transactions of the ASAE*, 38(2), 539-544.
- Gilley, J. E., Kottwitz, E. R., & Wieman, G. (1992). Darcy-Weisbach roughness coefficients for gravel and cobble surfaces. *Journal of Irrigation and Drainage Engineering*, 118(1), 104-112.
- Gilley, J. E., Kottwitz, E. R., & Wieman, G. A. (1991). Roughness coefficients for selected residue materials. *Journal of Irrigation and Drainage Engineering*, 117(4), 503-514.
- Gómez, J., & Nearing, M. (2005). Runoff and sediment losses from rough and smooth soil surfaces in a laboratory experiment. *Catena*, 59(3), 253-266.
- Grayson, R., Holden, J., & Rose, R. (2010). Long-term change in storm hydrographs in response to peatland vegetation change. *Journal of Hydrology*, 389(3-4), 336-343.
- Green, A. (2019). Sustainable Drainage Systems (SuDS) in the UK. In Jegatheesan, V., Goonetilleke, A., van Leeuwen, J., Kandasamy, J., Warner, D., Myers, B., Bhuiyan, M., Spence, K., & Parker, G. (eds.), *Urban Stormwater and Flood Management: Enhancing the Liveability of Cities* (pp. 69-101). Cham: Springer International Publishing.
- Hirabayashi, Y., Mahendran, R., Koirala, S., Konoshima, L., Yamazaki, D., Watanabe, S., . . . Kanae, S. (2013). Global flood risk under climate change. *Nature Climate Change*, 3(9), 816.
- Holden, J., & Burt, T. (2002). Infiltration, runoff and sediment production in blanket peat catchments: implications of field rainfall simulation experiments. *Hydrological Processes*, 16(13), 2537-2557.

- Holden, J., Kirkby, M. J., Lane, S. N., Milledge, D. G., Brookes, C. J., Holden, V., & McDonald, A. T. (2008). Overland flow velocity and roughness properties in peatlands. *Water Resources Research*, 44(6).
- Jackson, B., Wheeler, H., McIntyre, N., Chell, J., Francis, O., Frogbrook, Z., . . . Solloway, I. (2008). The impact of upland land management on flooding: insights from a multiscale experimental and modelling programme. *Journal of Flood Risk Management*, 1(2), 71-80.
- Jefferson, R. (2005). The conservation management of upland hay meadows in Britain: a review. *Grass and Forage Science*, 60(4), 322-331.
- Kourgialas, N. N., & Karatzas, G. P. (2013). A hydro-economic modelling framework for flood damage estimation and the role of riparian vegetation. *Hydrological Processes*, 27(4), 515-531.
- Lane, S. N. (2001). More floods, less rain: changing hydrology in a Yorkshire context. *The Regional Review*, 12, 18-19.
- Lane, S. N., & Milledge, D. G. (2013). Impacts of upland open drains upon runoff generation: a numerical assessment of catchment-scale impacts. *Hydrological Processes*, 27(12), 1701-1726.
- Li, H., Ding, L., Ren, M., Li, C., & Wang, H. (2017). Sponge city construction in China: A survey of the challenges and opportunities. *Water*, 9(9), 594.
- Liu, H., Jia, Y., & Niu, C. (2017). "Sponge city" concept helps solve China's urban water problems. *Environmental Earth Sciences*, 76(14), 473.
- Macleod, C. J. A., Binley, A., Hawkins, S., Humphreys, M., Turner, L., Whalley, W., & Haygarth, P. (2007). Genetically modified hydrographs: what can grass genetics do for temperate catchment hydrology? *Hydrological Processes: An International Journal*, 21(16), 2217-2221.
- Macleod, C. J. A., Humphreys, M. W., Whalley, W. R., Turner, L., Binley, A., Watts, C. W., . . . Haygarth, P. M. (2013). A novel grass hybrid to reduce flood generation in temperate regions. *Scientific Reports*, 3, 1683.
- Manandhar, B. (2010). *Flood plain analysis and risk assessment of Lothar Khola*. (Master of Science), Institute of Forestry, Tribhuvan University, Phokara, Nepal.
- Marshall, M. R., Francis, O. J., Frogbrook, Z. L., Jackson, B. M., McIntyre, N., Reynolds, B., . . . Chell, J. (2009). The impact of upland land management on flooding: results from an improved pasture hillslope. *Hydrological Processes*, 23(3), 464-475.
- Martin, D., Fraser, M. D., Pakeman, R. J., & Moffat, A. M. (2013). Natural England Review of Upland Evidence 2012 - Impact of moorland grazing and stocking rates. *Natural England Evidence Review*, 06.
- Medeiros, S. C., Hagen, S. C., & Weishampel, J. F. (2012). Comparison of floodplain surface roughness parameters derived from land cover data and field measurements. *Journal of Hydrology*, 452, 139-149.
- Merriam, K. E., Markwith, S. H., & Coppoletta, M. (2018). Livestock exclusion alters plant species composition in fen meadows. *Applied Vegetation Science*, 21(1), 3-11.
- Met Office. (2020). *UK Climate averages: Shap weather station 1981-2010*. Available at: <https://www.metoffice.gov.uk/research/climate/maps-and-data/uk-climate-averages/gcwn4cte6> [Accessed 09/01/2020].
- Meyles, E., Williams, A., Ternan, J., Anderson, J., & Dowd, J. (2006). The influence of grazing on vegetation, soil properties and stream discharge in a small Dartmoor catchment,

- southwest England, UK. *Earth Surface Processes and Landforms: The Journal of the British Geomorphological Research Group*, 31(5), 622-631.
- Middelkoop, H., Daamen, K., Gellens, D., Grabs, W., Kwadijk, J. C., Lang, H., . . . Wilke, K. (2001). Impact of climate change on hydrological regimes and water resources management in the Rhine basin. *Climatic Change*, 49(1-2), 105-128.
- Mwendera, E., & Feyen, J. (1994). Effects of tillage and rainfall on soil surface roughness and properties. *Soil Technology*, 7(1), 93-103.
- Myers, T. (2002). Modeling laminar sheet flow over rough surfaces. *Water Resources Research*, 38(11), 1230-1242.
- Natural England. (2012). *Higher Level Stewardship. Environmental Stewardship Handbook. Fourth edition - January 2013*. UK: Natural England.
- Nicholson, A., Wilkinson, M., O'Donnell, G., & Quinn, P. (2012). Runoff attenuation features: a sustainable flood mitigation strategy in the Belford catchment, UK. *Area*, 44(4), 463-469.
- Nisbet, T., Roe, P., Marrington, S., Thomas, H., Broadmeadow, S., & Valatin, G. (2015). *Slowing the flow at Pickering, final report phase II for the department of environment, food and rural affairs*. Project RMP5455. Defra: London.
- O'Connell, P., Ewen, J., O'Donnell, G., & Quinn, P. (2007). Is there a link between agricultural land-use management and flooding? *Hydrology and Earth System Sciences Discussions, European Geosciences Union*, 11(1), 96-107.
- Parsons, A. J., & Abrahams, A. D. (1989). A miniature flume for sampling interrill overland flow. *Physical Geography*, 10(1), 85-94.
- Phillips, J. V., & Tadayon, S. (2006). *Selection of Manning's roughness coefficient for natural and constructed vegetated and non-vegetated channels, and vegetation maintenance plan guidelines for vegetated channels in Central Arizona*. Washington, DC, USA: US Department of the Interior, US Geological Survey.
- Pinches, C. (2013). *Upland Hay Meadows: What Management Regimes Maintain the Diversity of Meadow Flora and Populations of Breeding Birds?* Natural England report NEER005. UK: Natural England.
- Roels, J. (1984). Flow resistance in concentrated overland flow on rough slope surfaces. *Earth Surface Processes and Landforms*, 9(6), 541-551.
- Rogger, M., Agnoletti, M., Alaoui, A., Bathurst, J., Bodner, G., Borga, M., . . . Hall, J. (2017). Land-use change impacts on floods at the catchment scale—Challenges and opportunities for future research. *Water Resources Research*, 53(7), 5209-5219.
- Schafer, K. (1986). Experiments with catch crops for erosion control in maize production. *Wirtschaftseigene Futter*, 32, 60-71.
- Schilling, K. E., Gassman, P. W., Kling, C. L., Campbell, T., Jha, M. K., Wolter, C. F., & Arnold, J. G. (2014). The potential for agricultural land use change to reduce flood risk in a large watershed. *Hydrological Processes*, 28(8), 3314-3325.
- Sharma, A., Pezzaniti, D., Myers, B., Cook, S., Tjandraatmadja, G., Chacko, P., . . . Koth, B. (2016). Water sensitive urban design: An investigation of current systems, implementation drivers, community perceptions and potential to supplement urban water services. *Water*, 8(7), 272.
- Short, C., Clarke, L., Carnelli, F., Uttley, C., & Smith, B. (2019). Capturing the multiple benefits associated with nature-based solutions: Lessons from a natural flood management project in the Cotswolds, UK. *Land degradation and development*, 30(3), 241-252.

- Shuttleworth, E. L., Evans, M. G., Pilkington, M., Spencer, T., Walker, J., Milledge, D., & Allott, T. E. (2019). Restoration of blanket peat moorland delays stormflow from hillslopes and reduces peak discharge. *Journal of Hydrology X*, 2, 100006.
- Soulsby, C. (1993). Contrasting hydrological regimes in two ploughed forest soils in upland Wales. *Forestry: An International Journal of Forest Research*, 66(2), 153-170.
- Sturm, T. (2001). *Open Channel Hydraulics*. New York: McGraw-Hill Science.
- Wallace, E. E., & Chappell, N. A. (2019). Blade Aeration Effects on Near-Surface Permeability and Overland Flow Likelihood on Two Stagnosol Pastures in Cumbria, UK. *Journal of Environmental Quality*, 48(6), 1766-1774.
- Wallace, E. E., & Chappell, N. A. (2020). A statistical comparison of spatio-temporal surface moisture patterns beneath a semi-natural grassland and permanent pasture: From drought to saturation. *Hydrological Processes*, 1-21.
- Wheater, H., & Evans, E. (2009). Land use, water management and future flood risk. *Land Use Policy*, 26, S251-S264.
- Wingfield, T., Macdonald, N., Peters, K., Spees, J., & Potter, K. (2019). Natural flood management: Beyond the evidence debate. *Area*, 51(4), 743-751.
- Wolton, R. (2000). The control of soft rush *Juncus effusus* by cutting. *Journal of Practical Ecology and Conservation*, 4(1), 18-26.
- Wood, S., Sebastian, K., & Scherr, S. J. (2000). *Agroecosystems*. Pilot analysis of global ecosystems. Washington, DC, USA: International Food Policy Research Institute and World Resources Institute.
- Wu, F.-C., Shen, H. W., & Chou, Y.-J. (1999). Variation of roughness coefficients for unsubmerged and submerged vegetation. *Journal of Hydraulic Engineering*, 125(9), 934-942.
- Yoshikawa, K., Overduin, P. P., & Harden, J. W. (2004). Moisture content measurements of moss (*Sphagnum* spp.) using commercial sensors. *Permafrost and Periglacial Processes*, 15(4), 309-318.



## Chapter 4. The influence of land management and season on flood mitigation in two UK upland catchments

<sup>1</sup>Bond, S., <sup>1</sup>Willis, T., <sup>2</sup>Johnston, J., <sup>3</sup>Crowle, A., <sup>1</sup>Klaar, M.J., <sup>1</sup>Kirkby, M.J. and <sup>1</sup>Holden, J.

<sup>1</sup>water@leeds, School of Geography, University of Leeds, Leeds, LS2 9JT, UK.

<sup>2</sup>Natural England, Wayfaring House, Murley Moss Business Park, Oxenholme Road, Kendal, UK.

<sup>3</sup>Natural England, Foss House, Kings Pool, Peasholme Green, York, UK

### 4.1 Abstract

As the frequency and magnitude of storm events increase with climate change, understanding how season and management influence flood peaks is essential. The influence of season and management of grasslands on flood peak timing and magnitude was modelled for Swindale and Calderdale, two catchments in northern England. Spatially-Distributed TOPMODEL was used to investigate two scenarios across four storm events using empirically based soil and vegetation data. The first scenario applied seasonal changes in vegetative roughness, quantifying the effect on flood peaks at catchment scale. The second scenario modelled the influence of grassland management from historical high-intensity grazing to a series of natural succession stages between grassland and woodland, and a conservation-based management. Model outputs were analysed by flow type, measuring total, overland and base flow peaks at the catchment outlet. Seasonal changes to vegetation were found to increase overland flow peaks by up to +2.2 % in winter and reduce them by -5.5 % in summer compared to the annual average. Percentage changes in flood peak due to hillslope grassland management scenarios were more substantial; overland flow peaks were reduced by up to 41 % in Calderdale, where extensive woodland development was the most effective mitigation strategy, and up to 35 % in Swindale, where a rank grassland dominated catchment was the most effective. Conservation-based farming practices were also useful, reducing overland flow peak by up to 42 % compared to the high intensity grazing scenario. Neither management nor seasonality had significant influence on the timing of runoff peaks. Where overland flow dominates, especially in catchments with shallow soils, surface roughness was found to be more influential than soil permeability for

flood mitigation. We recommend that seasonal changes to roughness are considered alongside the spatial distribution of Natural Flood Management in mosaiced upland catchments.

## 4.2 Introduction

Flooding is a key concern as extreme weather events increase globally (Carrick et al., 2019; Chan et al., 2018; Priestley, 2017). Natural flood management (NFM), as a form of nature-based flood risk solutions, has been adopted in the European Union (WG POM, 2014) and UK (Defra and Coffey, 2017; National Audit Office, 2020), and is recommended as both a sustainable and affordable approach that can be used alongside traditional flood management methods. In the UK, NFM is most often applied in uplands which are generally located in a wet, temperate climate (Köppen classification Cfb with small areas of Cfc, Kottek et al. (2006)) and are likely to experience greater increases in precipitation compared to lowland sites (Burt and Holden, 2010). Many UK headwaters are covered by blanket peat (Holden et al., 2007a, Xu et al., 2018), for which saturation-excess overland flow dominates (Holden and Burt, 2003). This hydrological feature is likely shared by organo-mineral (OM) soil grasslands, typically found in the uplands downslope of peat headwaters. OM soils, also known as shallow peaty soils, are defined as having a surface horizon  $\leq 40$  cm deep with  $>20\%$  organic content (Forestry Commission, 2016, Holden et al., 2007a, Smith et al., 2007, Joint Nature Conservation Committee, 2011). Although OM soils underlie large swathes of land, including approximately 31% of Europe, 11% of England and Wales (of which 59% are in uplands), and 50% of Scotland and Ireland (Bol et al., 2011), very little is known about their hydrological function (Bond et al., 2021). However, the hydrology of these soils, and influence of grassland management upon them, may be important factors to consider in flood mitigation efforts.

Grasslands account for 69% of global agricultural land, including 60% of the UK (Wood et al., 2000, Defra, 2016). In upland England, OM soils underlie 29% of all rough grassland, 35% of all bracken and 33% of all acid grasslands, and are typically used for livestock grazing (Bol et al., 2011). Although further research is needed to fully assess the influence of grazing on hydrological processes in Europe, current evidence suggests that grazing, especially

'overgrazing', likely increases catchment runoff via influence on soils and vegetation (Minea et al., 2021). Field studies have shown that hydraulic conductivity and infiltration rates are lower in areas subject to grazing due to the influence of compaction (Holden et al., 2007b, Zhao, 2008). Where soils are significantly compacted there is a reduction in macropore formation and root growth (Greenwood and McKenzie, 2001) from which infiltration-excess overland flow may be induced. Grazing has also been shown to reduce wetness thresholds in soils so that field capacity is reached more rapidly in storm events, contributing to rapid runoff pathways and increased stream discharge (Meyles et al., 2006). Selective grazing by animals changes the structure and volume of vegetation present, which may alter surface roughness. Surface roughness is an important modifier of overland flow with research showing that vegetation has the capacity to significantly reduce overland flow velocity with varying effectiveness depending on season and management (Bond et al., 2020, Holden et al., 2008, Monger et al., 2022). Vegetation roughness retains water so that duration of overland flow during storm events can be longer in rougher vegetation (Bond et al., 2021), potentially delaying flood peaks. Change in management can alter hydrological function, although existing estimates of time taken for grassland soil hydrological function to 'recover' vary significantly between 5 and 62 years (Gifford and Hawkins, 1978, Holden et al., 2007).

Upland UK grasslands have great capacity to be managed for NFM as they are typically 'mosaiced' landscapes for which there are multiple uses such as livestock grazing, hay meadows for production and leisure activities. In 2021, the UK Government announced plans for a new approach to land management under Future Farming Schemes (Defra, 2021b, 2022a, 2022b). The basis of this proposal is a move away from paying farming subsidies based upon area to one that rewards the provision of public goods. With incentives to introduce nature-based methods, it is essential that the implications are understood on a catchment scale. Considerations also need to be made regarding land-use configuration for which 'sensitive' catchment areas, such as the riparian or hilltoe zones, could have three times more influence on flow peaks than the same management applied to steeper hillslope locations (Gao et al., 2016).

A modelling approach allows land management scenarios to be tested at the catchment scale before implementation, informing intervention effectiveness and accounting for seasonal and spatial influences. Spatially Distributed TOPMODEL (SD-TOPMODEL), developed by Gao et al. (2015) and used in our research, is a fully distributed model, which functions well in temperate humid upland systems, allowing parameters to be applied to individual land covers. Therefore, the mosaiced nature of catchments can be represented, mirroring real-world differences in soil and land cover types which can be directly derived from empirical sources.

Previous empirical work on upland grasslands has shown that seasonality and management are important controls of vegetative surface roughness, which strongly modifies overland flow velocity. At the hillslope scale, Bond et al. (2020) found winter velocities to be significantly higher than in summer for four common grassland land covers; seasonal management practices, including grazing and hay meadow cutting, also strongly influenced overland flow velocity. Following this work, we directly apply the observed field data to SD-TOPMODEL to test the impact of upscaling these findings to a landscape scale, for which there is currently limited information (Dadson et al., 2017, Burgess-Gamble et al., 2017, Rogger et al., 2017, Ellis et al., 2021). The influence of seasonality at the catchment scale may be especially important for NFM as most large storm events occur in winter in the UK when vegetation is the least rough; the occurrence of large winter storms is also expected to increase with climate change (Lowe et al., 2018).

Two UK upland catchments are modelled, allowing relative differences in soil properties and surface roughness between land covers to be represented. Two scenario sets are investigated. The first scenario set models, for the first time, the influence of seasonality on surface roughness and how this impacts runoff peaks. Current land cover will be modelled, applying only surface roughness changes. The second scenario set investigates grassland management change from intensive grazing to natural succession of grassland into woodland, and conservation management. Excluding the high intensity grazing management for which the extent of grazing is expanded, all other management scenarios retain the same spatial configuration within the catchment, changing only the type of land cover within each segment (i.e., within each field). In both scenarios, land management

change will be applied only to the parts of the system which are currently OM soil grasslands, so that their influence on river flow peaks in response to major rainfall events can be assessed.

## 4.3 Methods

### 4.3.1 Study sites

Two catchments were chosen for the study: Swindale (54°30'23"N , 002°45'47"W, Figure 4.1, Table 4.1) and Upper Calderdale (53°43'45"N , 002°07'41"W, Figure 4.2, Table 4.1), both with peatland headwaters and predominantly grassland-covered OM soil on their mid- and lower-catchment regions. Both catchments have experienced recent flood events and were chosen for their similar land covers, within which there is opportunity to implement NFM. However, the two catchments have very different topographies.

Swindale is a 15.3 km<sup>2</sup> catchment in the Lake District, UK of which approximately 2.89 km<sup>2</sup> is currently used as commons grazing for sheep, 1.84 km<sup>2</sup> is ungrazed commons land, 8.48 km<sup>2</sup> is ungrazed hill land (locally called Mosedale) and 2.66 km<sup>2</sup> is an upland farm situated within a U-shaped valley. Swindale Farm is managed as part of a higher-level stewardship scheme which pays land managers to use environmentally conscious practices (Natural England, 2012).

Upper Calderdale, specifically the River Calder from source to Walsden Water at Todmorden and henceforth referred to as Calderdale, is a 21 km<sup>2</sup> basin-shaped catchment which has a relatively flat catchment top and bottom with steep slopes and has been heavily modified (Defra, 2021a). It is managed by multiple authorities, including Calderdale Council and private landowners.

Hereafter, parcels of land are referred to as land 'covers', encompassing both the physical surface of that land parcel, its land use (i.e. the economic purpose of that land) and any specific management applied. Since land cover, use and management are all known to influence hydrological function, they have been considered together. A breakdown of land covers is given in Table 4.1 for Swindale and Table 4.2 for Calderdale.

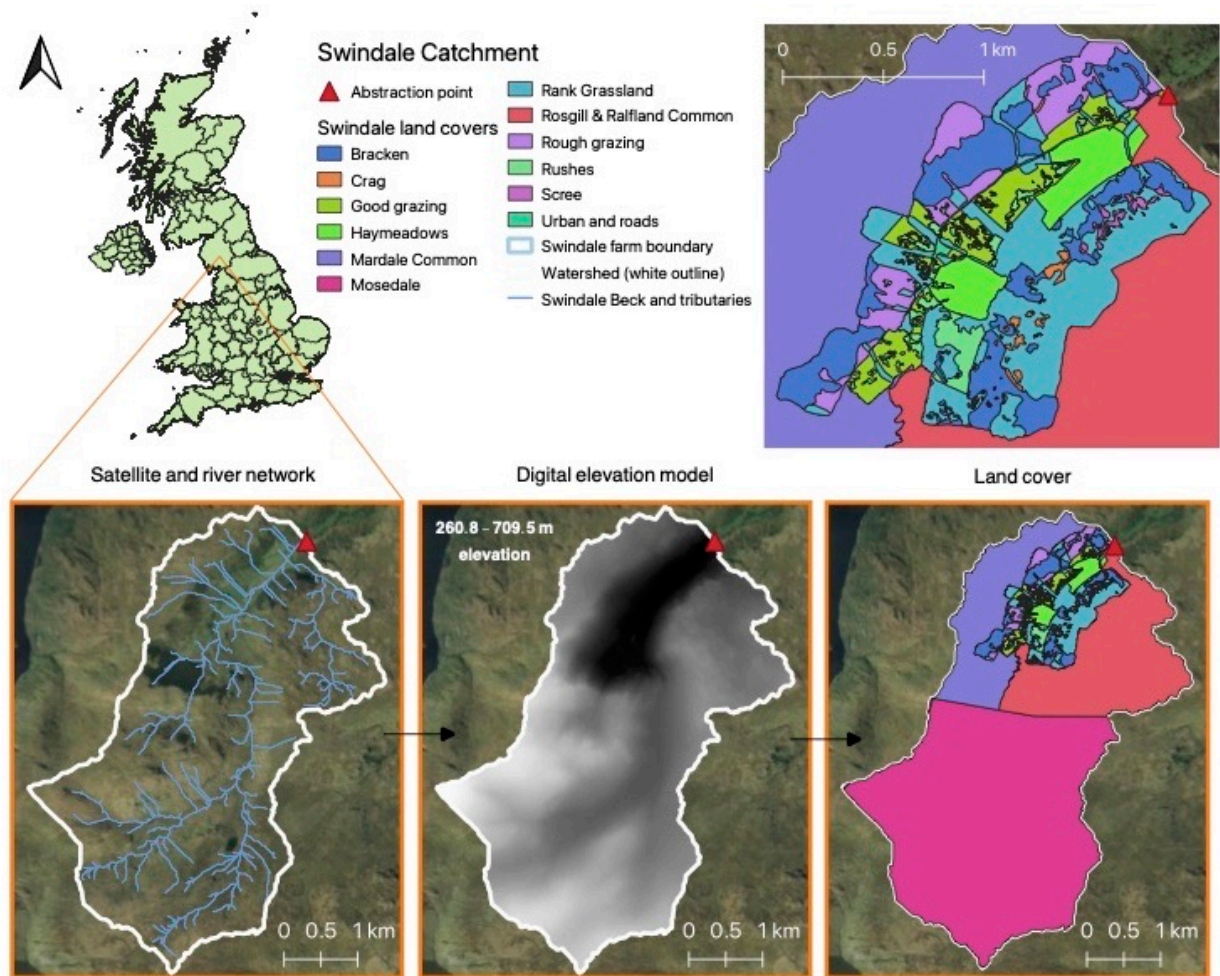

Figure 4.1: Swindale catchment and current land cover. Land cover maps provided by RSPB Haweswater.

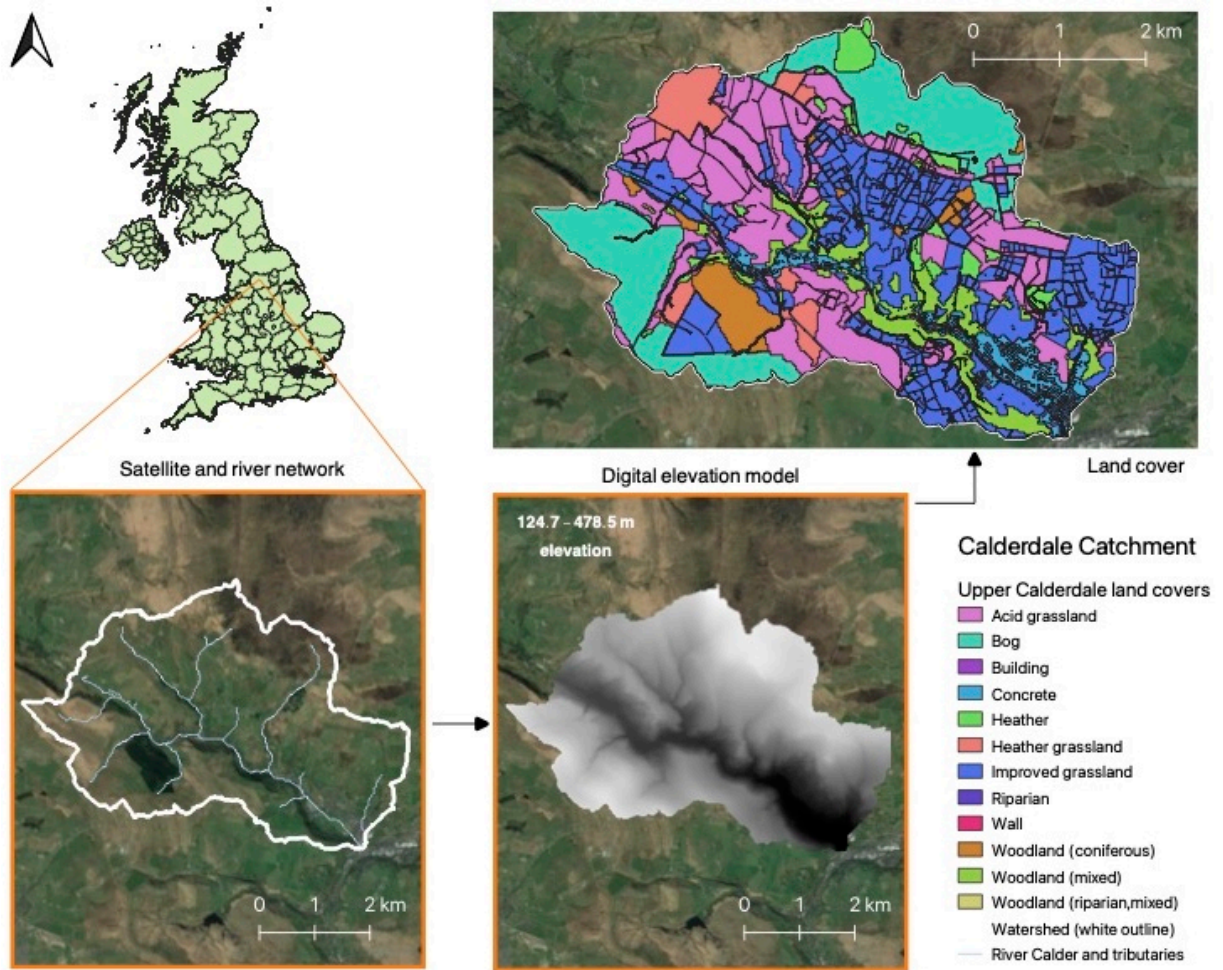

Figure 4.2: Upper Calderdale catchment and current land cover. Land use established from CEH land cover 2015 data.

Table 4.1: Swindale location, area, mean slope, elevation, climate and current catchment land covers, including their CEH 2015 designated land cover, area, grazing status and primary underlying soil type. Climate data derived from Met Office (2022a). Primary underlying soil type derived from Cranfield University (2022). Swindale land cover was established using data provided by RSPB Haweswater - for a description of Swindale land covers, including dominant vegetation species present, see Supporting Information 2. CEH land cover designation was established from CEH land cover 2015 data – for a description of land covers, see Morton et al. (2011). For ‘equivalent’ land covers between Swindale and Calderdale, where model parameters used to represent land covers are the same, see Supporting Information 2.

<b>Swindale</b>					
54°30'23"N, 002°45'47"W			Area: 15.3 km <sup>2</sup>		
Mean Slope: 6.9 ± 5.3°			Elevation: 260 m – 709 m		
<b>RSPB land cover (abbreviation)</b>	<b>CEH land cover designation</b>	<b>Area (km<sup>2</sup>)</b>	<b>Grazing status</b>	<b>Primary underlying soil type</b>	<b>Climate</b>
<b>Mosedale</b> (MD)	Acid	8.48	Deer	Blanket bog peat: Winter Hill 1011b  Organo-mineral: Malvern 611a and Bangor 311e	1991 – 2020 Shap – 5km from Swindale  Mean annual precipitation: 1863 mm  Mean daily temperature: Max = 11.8°C Min = 4.3°C
<b>Rosgill &amp; Ralfland Common</b> (RRC)	grassland/Peat bog	2.89	Sheep and deer		
<b>Mardale Common</b> (MC)		1.84	Deer		
<b>Rank Grassland</b> (RG)	Improved/Acid	0.71	Ungrazed		
<b>Bracken</b> (B)	grassland	0.51	Largely ungrazed, depends on location		
<b>Rough grazing</b> (RoG)		0.25	Sheep		
<b>Good grazing</b> (GG)	Improved	0.24	Sheep		
<b>Hay Meadows</b> (HM)	grassland	0.20	Sheep		
<b>Rushes</b> (R)	Improved/Acid	0.12	Largely ungrazed, depends on location		
<b>Crag</b> (C)		0.03	Ungrazed		
<b>Scree</b> (S)	Acid grassland	0.02	Ungrazed		
<b>Urban &amp; Roads</b> (UR)		0.02	Ungrazed		



Table 4.2: Calderdale location, area, mean slope, elevation, climate and current catchment land covers, including area, grazing status and primary underlying soil type. Climate data derived from Met Office (2022b). Primary underlying soil type derived from Cranfield University (2022). Calderdale land cover was established using CEH land cover 2015 data – for a description of land covers, see Morton et al. (2011). Grazing density information was unavailable for the majority of land covers. For ‘equivalent’ land covers between Swindale and Calderdale, where model parameters used to represent land covers are the same, see Supporting Information 2.

<b>Calderdale</b>					
<b>53°43'45"N, 002°07'41"W</b>		Area: 21 km <sup>2</sup>			
<b>Mean Slope: 10.2 ± 7.8°</b>		Elevation: 124 m – 478 m			
<b>CEH land cover (abbreviation)</b>		<b>Area (km<sup>2</sup>)</b>	<b>Grazing status</b>	<b>Primary underlying soil type</b>	<b>Climate</b>
<b>Peat Bog</b>	(PB)	3.80	Ungrazed	Organo-mineral: Belmont 0651a and Wilcocks 0721c	1991 – 2020 Bingley SAMOS – 18.5 km from Calderdale  Mean annual precipitation: 1057 mm  Mean daily temperature: Max = 12.1°C Min = 5.5°C
<b>Acid Grassland</b>	(AG)	5.20	Predominantly sheep with some cattle		
<b>Buildings</b>	(Bd)	0.22	Ungrazed		
<b>Concrete (Urban &amp; Roads)</b>	(Co)	1.37	Ungrazed		
<b>Drystone Wall</b>	(DW)	0.46	Ungrazed		
<b>Heather</b>	(H)	0.72	Ungrazed		
<b>Heather Grassland</b>	(HG)	1.01	Largely ungrazed, depends on location		
<b>Improved Grassland</b>	(IG)	5.57	Predominantly sheep with some cattle and horses		
<b>Riparian Grassland</b>	(RiG)		Ungrazed		
<b>Woodland, Coniferous</b>	(WC)	0.78	Ungrazed		
<b>Woodland, Mixed</b>	(WM)	1.65	Ungrazed		
<b>Woodland, Riparian (mixed)</b>	(WR)	0.03	Ungrazed		

### 4.3.2 SD-TOPMODEL

To investigate the influence of seasonal changes in surface roughness and land cover on downstream flow peaks, SD-TOPMODEL (Gao et al., 2015) was used. SD-TOPMODEL uses the original runoff equations from TOPMODEL (Beven and Kirkby, 1979), solving these for each user defined regular grid cell in a fully distributed grid. This approach is preferred to the original semi-distributed TOPMODEL because it allows infiltration to reach the saturated zone at different times, according to local wetness, and, more importantly in the present context, by generating overland flow in each grid cell, and routing it according to local conditions. Critically, SD-TOPMODEL allows the user to vary surface landscape properties that influence overland flow velocity, and subsurface properties that influence infiltration and soil water storage. Therefore, it is ideal for assessing the influence of season and land cover on modelled flood risk. The model is well suited to catchments with shallow soils and moderate topography (Gao et al., 2015; Beven et al., 2020), therefore is ideal for Swindale and Calderdale.

#### DEM, land cover and rainfall

In Swindale catchment a 5 m digital elevation model (DEM) was used and in Calderdale a 20 m DEM was used, both derived from photogrammetry and LiDAR data sources (Ordnance Survey, June 2018). Land cover data of the same resolution as the DEM were used in the model to describe spatial distributions of land and vegetation types. The resolution used was the highest possible as determined by data availability and limitations to model run time (maximum 48 hours). For Calderdale, the 2017 CEH land cover data were used to represent key land cover types (CEH, 2017). For Swindale, land cover data were provided by RSPB Haweswater. Different land cover sources were used so that field data could be directly applied to corresponding baseline land covers.

Using FEH/ReFH (Kjeldsen et al., 2005), four storm events were produced for each catchment with durations of 6 hours and 24 hours, and frequencies of 1 in 10-year and 1 in 50-year events (Table 4.2). Each ReFH storm had a timestep of 15 minutes between rainfall and runoff observations. These synthetic storm events were used so that specific return-period events could be represented, allowing like-for-like recurrence interval comparison

between catchment response. Within each storm event, rainfall was distributed in a Gaussian fashion, using the winter storm profile where rain falls continuously for the duration of the event with the highest intensity in the middle of the storm.

*Table 4.3: Modelled storm events and their rainfall intensity*

<b>Catchment</b>	<b>Storm duration (hours)</b>	<b>Storm recurrence interval</b>	<b>Total rainfall (mm)</b>	<b>Rainfall intensity (mm/hour)</b>	<b>Maximum rainfall intensity (mm/hour)</b>
<b>Swindale</b>	6	1 in 10 years	67.45	11.24	28.22
<b>Swindale</b>	6	1 in 50 years	85.36	14.23	35.71
<b>Swindale</b>	24	1 in 10 years	121.63	5.07	13.23
<b>Swindale</b>	24	1 in 50 years	148.06	6.17	16.10
<b>Calderdale</b>	6	1 in 10 years	36.11	6.02	15.11
<b>Calderdale</b>	6	1 in 50 years	50.38	8.40	21.08
<b>Calderdale</b>	24	1 in 10 years	61.24	2.55	6.64
<b>Calderdale</b>	24	1 in 50 years	81.73	3.41	8.87

Regardless of season, evapotranspiration during individual storm events (mean of 1-2 mm per day; Blyth et al 2019) is very small compared to storm size (36-148 mm), therefore we chose not to include its within-storm effects in either scenario (Haan et al., 1994). This also ensured that changes in runoff response were driven by the interventions alone. By excluding evapotranspiration from the seasonality scenarios, model results could also be considered conservative, where the addition of further water loss would only produce more extreme differences in seasonal runoff.

#### Parameter sources

In SD-TOPMODEL, three key parameters are employed to account for catchment properties:  $K$ , the notional hydraulic conductivity of the soil;  $m$ , a scaling parameter describing the active water storage of the soil; and  $K_v$ , an overland flow velocity parameter representing surface roughness (Gao et al., 2015). A fourth parameter, interception,  $I_n$ , is an additional feature to SD-TOPMODEL, created by Boisgontier (2018) which allows interception to be spatially distributed. The derivation for each parameter is given in Appendix C1.

Parameters are input into SD-TOPMODEL in two formats, a parameters file and in map format. The parameters file is a scaling file which contains one value for each of the first three key parameters. These values are based on the best fit of modelled to observed data taken from a storm event as part of model calibration and, once chosen, remain the same for all model runs. Best fit is determined using the Nash-Sutcliffe Efficiency (NSE) and comparative shapes of the observed and modelled hydrographs. As scaling factors, the values in the parameters file do not necessarily reflect observed field data. To spatially distribute the model, parameters are also represented in map format with one map for each parameter. With each map, a value is applied per cell based on measured or estimated field data from literature sources. All spatially distributed map values are relative to the largest land cover, maintaining the difference between land covers without using absolute field-based data. One map per parameter is produced for each model scenario.  $I_n$  is added in map-format only and not included in the parameters file.

Map parameters for SD-TOPMODEL were based on the relative relationship between land covers as measured in field campaigns (Table 4.4). Since  $m$  is calculated on a catchment scale,  $m$  was input to SD-TOPMODEL as a lumped value. A summary of how each parameter is derived from field data is given in Supporting Information 1 and a complete overview of the final relative parameter values for each scenario modelled is given in Appendix C2 for Swindale and Appendix C3 for Calderdale.

Table 4.4: Parameter sources and application to the baseline model. Scenarios use the same sources; further details can be found in Supporting Information 2 for Swindale and Supporting Information 3 for Calderdale.

Parameter	Field measurement	Source	Source field location	Baseline land covers data was used to represent in SD-TOPMODEL	
				Swindale	Calderdale
				<i>m</i>	<i>m</i> (catchment scale)
<i>K</i>	<i>K<sub>s</sub></i>	Bond et al. (2021)	Swindale	B, GG, HM, RG, RoG	IG, RiG
		Kingsbury-Smith (2019)	Calderdale		H, WC, WM, WR
		Branham and Strack (2014) – median value	Various – broad literature review	MD, RRC, MC	AG, PB
		Estimates		R = mean (GG, HM & RG); UR, C & S = as low as SD-TOPMODEL inputs allowed (impermeable surfaces)	HG = mean (RG & WM); Bd, Co, DW = as low as SD-TOPMODEL inputs allowed (impermeable surfaces)
<i>K<sub>v</sub></i>	Velocity, m s <sup>-1</sup>	Bond et al. (2020)	Swindale	GG, HM, RG, R	AG, IG, HG, RiG
		Holden et al. (2008) – <i>Eriophorum-Sphagnum</i> mix	Upper Wharfe, North Yorkshire, UK	MD, MC, RRC	PB
		Holden et al. (2008) – Bare peat		UR, C & S	Bd, C & DW
		Monger et al. (2022)	Naddle valley, Cumbria, UK (neighbours Swindale)	B	H, WC, WM & WR
		Estimates		RoG = mean of GG and RG	HG = mean of RG & WM
<i>I<sub>n</sub></i>	Interception, %	Herbst et al. (2006)	Swindon, Wiltshire, UK		H, HG
		Herbst et al. (2008)	Newbury, Berkshire, UK		WM, WR
		Gash et al. (1980)	Various – UK coniferous forest		WC

## Calibration and validation

SD-TOPMODEL was calibrated for each catchment using the four ReFH events, in place of observed data, to find the best combined model fit (i.e. the scaling file parameters which best represented all four storm events for the baseline model). The four calibrated storm events for each catchment are shown in Figure 4.3.

*Table 4.5: Calibration ranges, chosen calibrated values and Nash-Sutcliffe ranges for Swindale and Calderdale.*

<b>Parameter</b>	<b>Calibration range</b>	<b>Swindale calibrated value</b>	<b>Calderdale calibrated value</b>
<i>m</i>	0.006 – 0.02	0.008	0.008
<i>Kv</i>	5 – 30	9	12
<i>Ln(K)</i>	50 – 300	6.214608	6.109248
<b>Calibrated model Nash-Sutcliffe Efficiency range for all ReFH storms:</b>		0.9411 – 0.9657	0.8134 – 0.8947

Following calibration using the ReFH storm events, validation was conducted using observed rainfall and runoff data from local gauges (Figure 4.4; Figure 4.5). This ensured that the model was representative of real storm events in addition to being calibrated to ‘designed’ ReFH storms. For each catchment, the highest magnitude rainfall event was chosen from the available data.

In Swindale, 15-minute precipitation data were obtained from Mickleden station, approximately 24 km SWW of Swindale (Middle Fell Farm telemetry, Station number 586820, NY 28 06). 15-minute flow gauge data from Swindale Beck was recorded by the Environment Agency gauge near the catchment outlet (Station number 761114). These data were used to isolate Storm Ciara, a 1 in 2-year rainfall event (IDF curve in Appendix C4). For Swindale validation the NSE was 0.71 (Figure 4.4).

Calderdale was validated using 15-minute precipitation data obtained from Gorpley Reservoir gauging station (Station number 077066). 15-minute flow gauge data from the River Calder was recorded by the Environment Agency gauge in Todmorden at the catchment outlet (Station number F1207). These data were used to isolate a storm event

from 26th December 2015, a 1 in 100-year event (Amjid, 2017), which produced a NSE of 0.62 (Willis and Klaar, 2021; Figure 4.5).

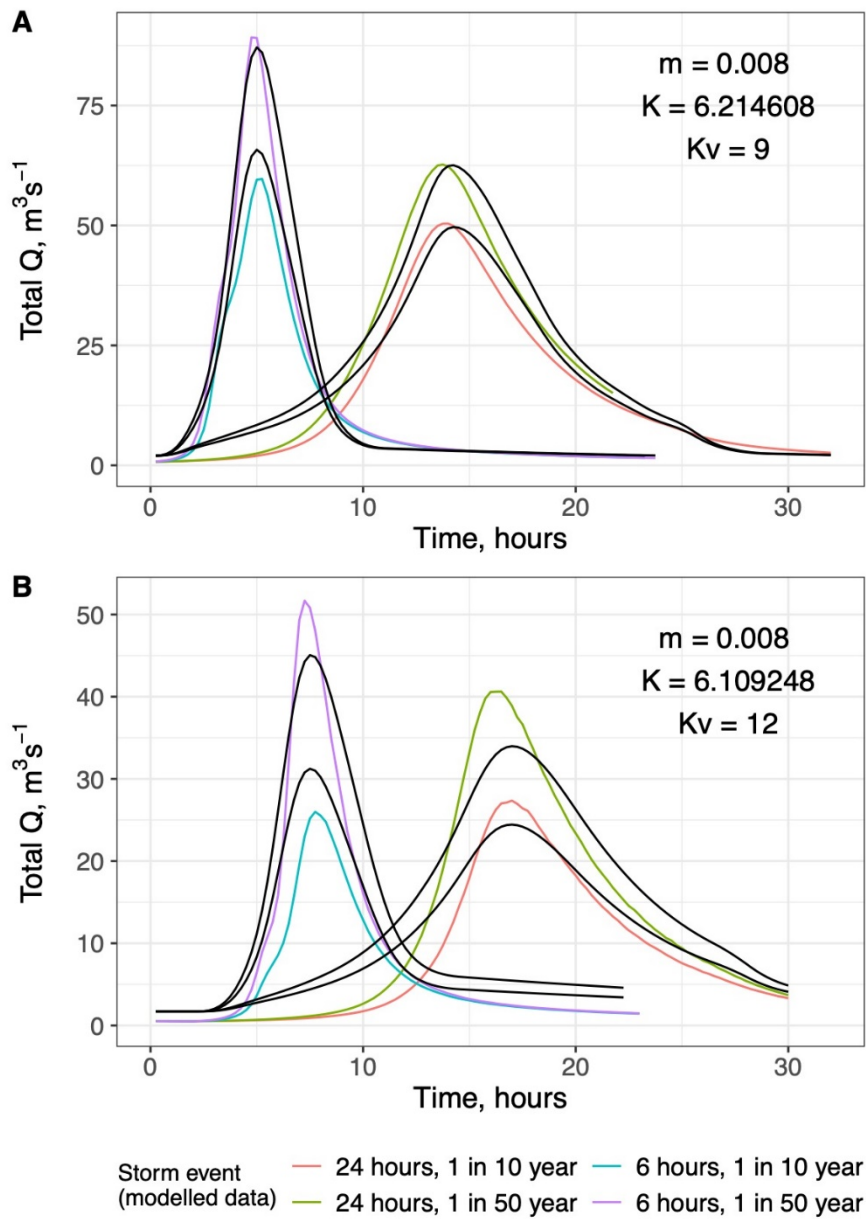

Figure 4.3: Final calibration model runs for Swindale (A) and Calderdale (B). The black line represents the ReFH data (in place of observed data) per storm event.

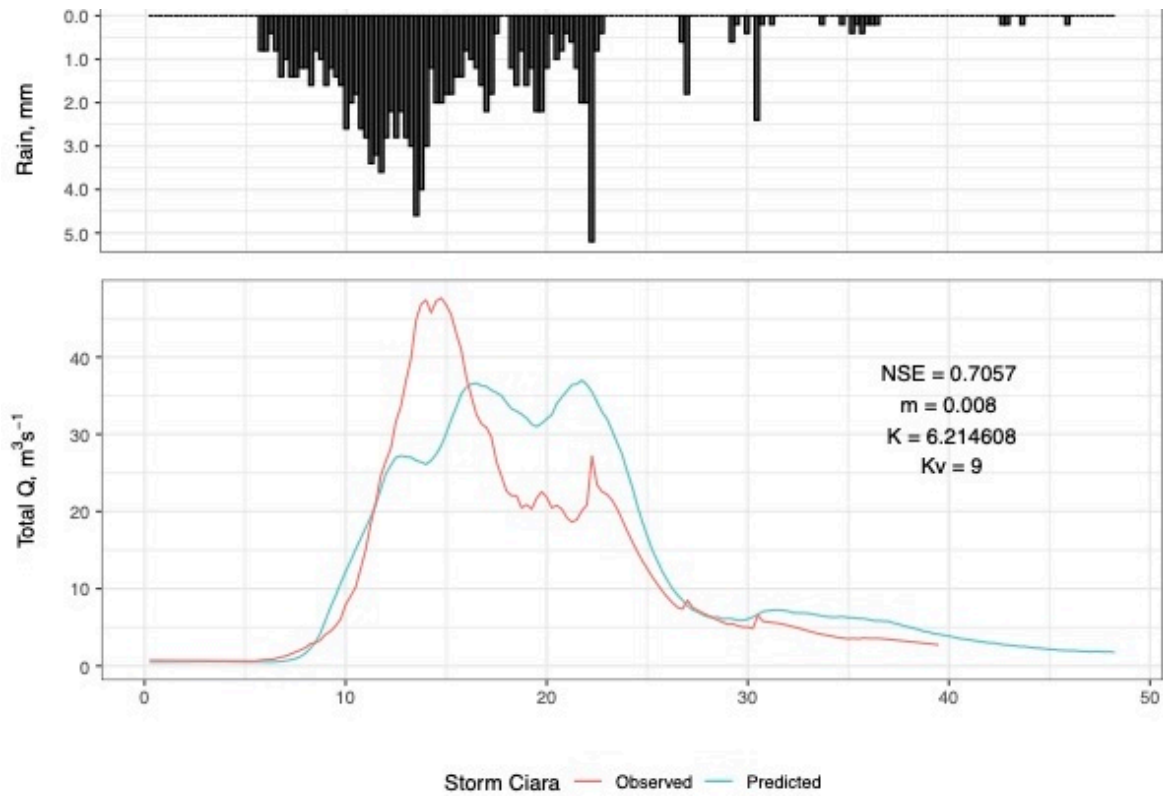

Figure 4.4: Swindale validation using Storm Ciara, a 1 in 2 year storm event

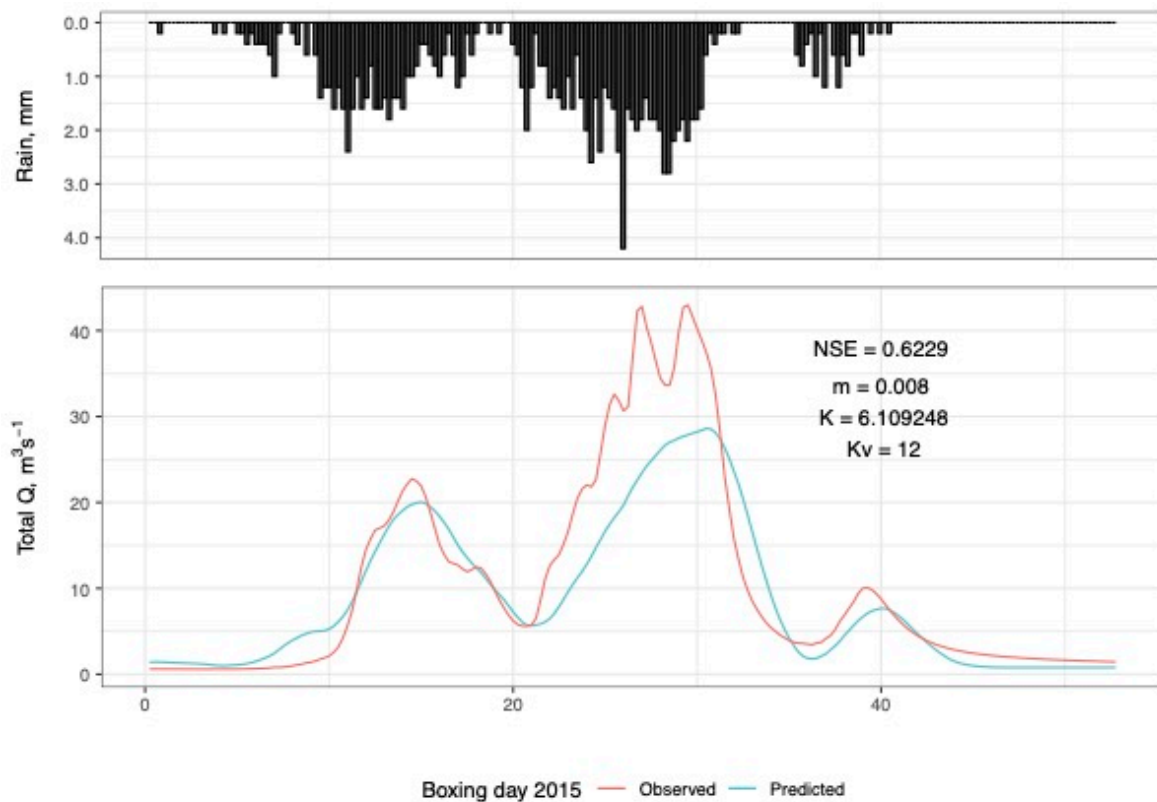

Figure 4.5: Calderdale validation using storm from 26<sup>th</sup> December 2015, a 1 in 100 year storm event



### 4.3.3 Scenarios tested

A variety of scenarios were tested (Table 4.6). Scenarios were designed to be compared with the baseline scenario, representing each catchment in its current land cover configuration where parameters were based on the annual average value. For the management scenarios, interception values, including for the baseline model, were for 'winter interception'; this was to provide a conservative estimate of  $I_n$ , since data sources were not directly from the catchments modelled.

#### Scenario 1: Seasonality

To test the influence of seasonal vegetation growth, decay and management on flood peak and duration, five scenarios were produced. All scenarios used the current land cover configuration and the same  $m$  and  $K$  values as the catchment baseline model.  $m$  and  $K$  were not changed seasonally. To represent season,  $K_v$  and  $I_n$  parameters were employed. Seasonal scenarios were compared to the baseline map, for which  $K_v$  and  $I_n$  parameters were the annual average value.

Through flume investigations at the hillslope scale, Bond et al. (2020) found significant seasonal differences in overland flow velocity as the result of seasonal growth, decay and management within different grassland types. Scaling up to the catchment scale,  $K_v$  was applied based on the relative difference in measured overland flow velocity as recorded in Swindale in April, June, July, September, and November by Bond et al. (2020) (Table 4.6; Appendices C2 & C3).

Within the months represented, April and November were chosen to represent 'winter', and June, July and September to represent 'summer'. This designation was based on Bond et al. (2020) who applied the same winter and summer comparisons. Since true winter (December to February) values could not be obtained, seasonal designation was based on the 2019 growing season for which April and November were relatively cold and therefore the vegetation reflected winter dormancy. Using this, summer and winter  $I_n$  was applied based on values obtained by Herbst et al. (2006), Herbst et al. (2008) and Gash et al. (1980).

## Scenario 2: Influence of grassland management

To test the potential role of upland management on flood peaks and timing, the catchment configuration and associated land cover parameters were altered based on seven management possibilities (Table 4.6). These included a historical land cover (1980s - 1990s) and future possibilities between 2 and 50 years from the present day. Management scenarios were informed by discussions with practitioners about what potential changes would be most feasible and would be supported by ongoing policy development. To specifically model grassland management, changes were applied to grassland designated areas of the baseline land cover only.

$K_v$ ,  $K$  and  $I_n$  parameters were employed, where literature suggests all change in response to management over the proposed time frames. Where scrub and woodland were introduced, it was assumed to be established scrub or broadleaf woodland with comparatively high  $K$  and  $I_n$ , and low  $K_v$ , to all grassland.

Land cover maps for each management scenario and the relative parameter differences are shown in Appendix C2 for Swindale and Appendix C3 for Calderdale.

Table 4.6: Seasonality and management scenarios tested. Historical land cover, based on high-intensity farming in the 1980s and 1990s, was determined through conversations with current land managers. For scenario maps, see Appendix C2 for Swindale and Appendix C3 for Calderdale.

Scenario	Scenario name	Scenario description	Baseline components maintained per scenario	Baseline components changed per scenario
Baseline	Baseline	Baseline map: annual average data, current catchment land cover		
Seasonality	1_1	April	<ul style="list-style-type: none"> <li>Land cover configuration</li> <li><math>m</math></li> <li><math>K</math></li> </ul>	<ul style="list-style-type: none"> <li><math>K_v</math></li> <li><math>I_n</math> (Winter = April &amp; November, Summer = June – September)</li> </ul>
	1_2	June		
	1_3	July		
	1_4	September		
	1_5	November		
Management	2_1	Revert to high-intensity grazing based on historical land cover.	<ul style="list-style-type: none"> <li><math>m</math></li> </ul>	<ul style="list-style-type: none"> <li>Land cover configuration</li> <li><math>K_v</math></li> <li><math>K</math></li> <li><math>I_n</math> (winter values only)</li> </ul>
	2_1a	(Calderdale only) High-intensity grazing based on Swindale 2_1, allowing for a direct comparison between catchments.		
	2_2	Passive management: catchment in 2 years' time if all active management were removed. Grazing fields and hay meadows are replaced by rank grassland.		
	2_3	Passive management: catchment in 5-10 years if all management were removed. Following scenario 3, scrub develops across 10% of the catchment.		
	2_4	Passive management: catchment in 10-50 years if all active management were removed. Following scenario 4, scrub and woodland develops across 20% of the catchment.		
	2_5	Passive management: extreme scenario. Catchment in 50+ years if all active management were removed and woodland spread to cover 80% of the catchment.		
	2_6	Active management: conservation management. Haymeadows are maintained for biodiversity, rank grassland and bracken are converted to woodland and scrub, low-density cattle grazing is introduced.		

#### 4.3.4 Analysis methods

Model outputs were analysed for each catchment, comparing each scenario to the baseline scenario. Due to catchment topography and its influence on baseflow calculations, Calderdale was overly sensitive to changes in permeability ( $K$ ) as the catchment outlet is predominantly urban which is represented as low permeability region in the model); therefore, Calderdale management scenarios were analysed for overland flow only. In Swindale, baseflow, and therefore total flow, could be modelled for all scenarios. The model limitations were not considered problematic because in upland catchments with shallow soils, particularly the OM grasslands on which NFM interventions were placed within this research, overland flow is the primary driver of flooding (Bond et al., 2021; Gao et al., 2016). Therefore, overland flow was chosen as the focus of analysis. In both catchments, changes in peak runoff were compared between scenarios and the baseline condition and the time to peak from rainfall start was measured. The shape of each model hydrograph was visually compared.

### 4.4 Results

In the following section, models runs are coded by month of the year they represent (seasonality scenarios) or the model number from Table 4.3 (management scenarios). Changes to peak runoff from the baseline scenario are given as percentages with the absolute difference in peak runoff volume from the baseline scenario for that storm event in parentheses. A table containing results in full is provided in Appendix C5 (Excel spreadsheet).

#### 4.4.1 Scenario set 1. Seasonality

##### Swindale

Seasonality had a strong influence on flood peak and timing for both total flow and overland flow, with the most substantial changes predicted in the 6-hour events (Figure 4.6; Figure 4.8). For all scenarios the highest flow peaks were predicted in November with up to 2.1 % ( $0.85 \text{ m}^3 \text{ s}^{-1}$ ) increase in overland flow peak and 1.4 % ( $0.84 \text{ m}^3 \text{ s}^{-1}$ ) increase in total runoff peak (both from the 6-hour, 1 in 10-year event) from the baseline scenario. The lowest

runoff peaks occurred in July with decreases in overland flow of up to 5.4 % ( $3.51 \text{ m}^3 \text{ s}^{-1}$ ; 6-hour 1 in 50-year) and decreases in total runoff of up to 5.7 % ( $3.39 \text{ m}^3 \text{ s}^{-1}$ ; 6-hour 1 in 10). The 24-hour storm events were more subdued in response than the 6-hour events, with peak total runoff varying between 1.6 % below baseline peak ( $0.80 \text{ m}^3 \text{ s}^{-1}$ ; 24-hour 1 in 10, July) and 0.2 % above baseline peak ( $0.13 \text{ m}^3 \text{ s}^{-1}$ ; 24-hour 1 in 50, November) and peak overland flow changing between -1.7% ( $0.50 \text{ m}^3 \text{ s}^{-1}$ ; September) and +1.6% ( $0.45 \text{ m}^3 \text{ s}^{-1}$ ; November; both 24-hour, 1 in 50-year) from the baseline model. Subsurface flow was the least influenced by changes in seasonality with all changes to peak runoff <0.03% different from the baseline model.

There were no delays to total runoff peak timing in the 6-hour storms, however a 15-minute peak delay was predicted for the April, June, July and September 24-hour 1 in 10-year storms and the 24-hour 1 in 50-year June event.

### Calderdale

Calderdale models produced a similar response to those for Swindale, also reacting to seasonality with the most pronounced changes in the 6-hour storm events. In Calderdale, the highest flow peaks occurred in April with up to 2.2% ( $0.87 \text{ m}^3 \text{ s}^{-1}$ ) increase in overland flow and 1.9 % ( $0.92 \text{ m}^3 \text{ s}^{-1}$ ) increase in total runoff (both from the 6-hour, 1 in 50-year event) from the baseline scenario (Figure 4.7; Figure 4.8). The lowest runoff peaks were found in September, from the 6-hour, 1 in 10-year event, with decreases in overland flow of up to 5.5 % ( $0.96 \text{ m}^3 \text{ s}^{-1}$ ) and decreases in total runoff of up to 5.1 % ( $1.21 \text{ m}^3 \text{ s}^{-1}$ ) from the baseline scenario. As with Swindale, the 24-hour storm events were more subdued in response than the 6-hour events, with the peak total runoff varying between 2.1 % below baseline peak (reduction of  $0.53 \text{ m}^3 \text{ s}^{-1}$ ; 24-hour, 1 in 10-year, September) and 1.7 % above baseline peak (increase of  $0.45 \text{ m}^3 \text{ s}^{-1}$ ; 24-hour, 1 in 10-year, April) and the peak overland flow changing between -2.3% (reduction of  $0.41 \text{ m}^3 \text{ s}^{-1}$ ; September) and +2.2% (increase of  $0.39 \text{ m}^3 \text{ s}^{-1}$ ; April) (both 24-hour 1 in 10) from the baseline model. Baseflow was more influenced by seasonality than in Swindale, changing by  $\pm 0.85\%$  from the baseline model (July compared to November, both 24-hour, 1 in 10-year).

In Calderdale, for the 6-hour events, only the April 1 in 10-year event, produced a peak time difference (15 minutes earlier) compared to the baseline model. In the 24-hour events, the 1 in 10-year storm produced peak flow 15 minutes after the baseline model peak in June, July and September, and 15 minutes before the baseline model in November. For the 24-hour, 1 in 50-year model, peak total runoff was 15 minutes delayed in all months compared to the baseline model.

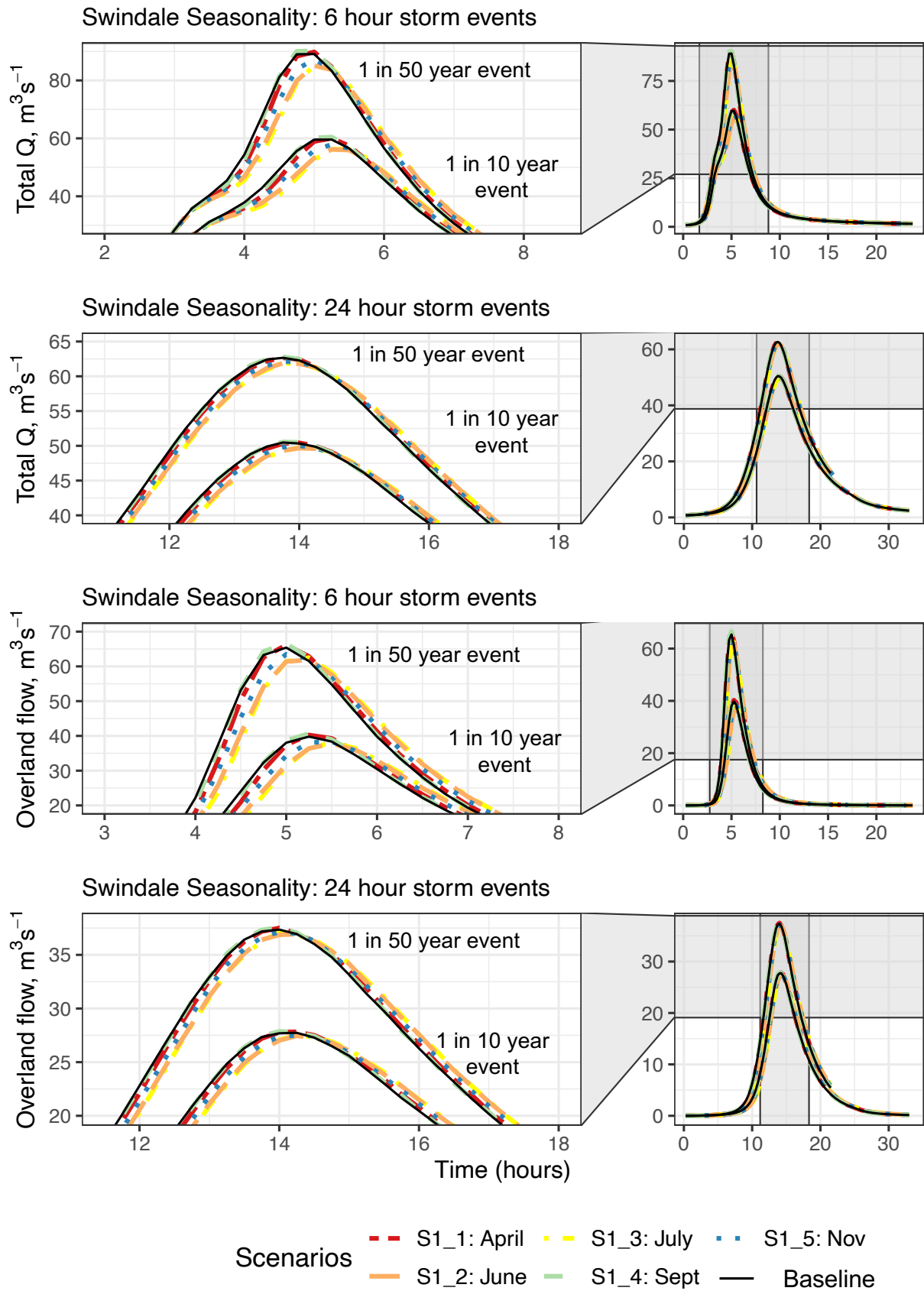

Figure 4.6: The influence of seasonality on total runoff and overland flow for runoff peak and timing in Swindale. The black line represents the baseline model (annual average).

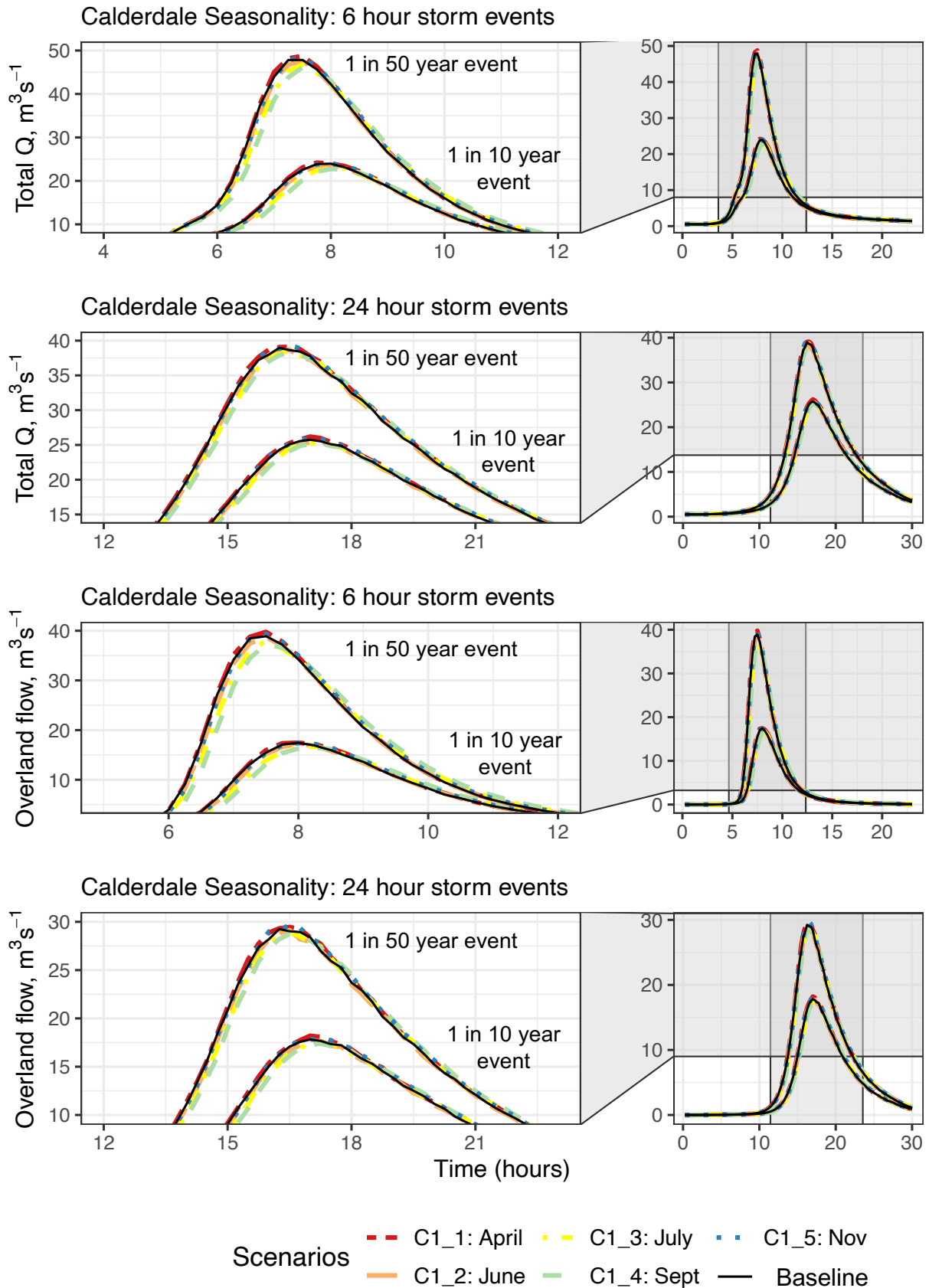

Figure 4.7: The influence of seasonality on total runoff and overland flow for runoff peak and timing in Calderdale. The black line represents the baseline model (annual average).



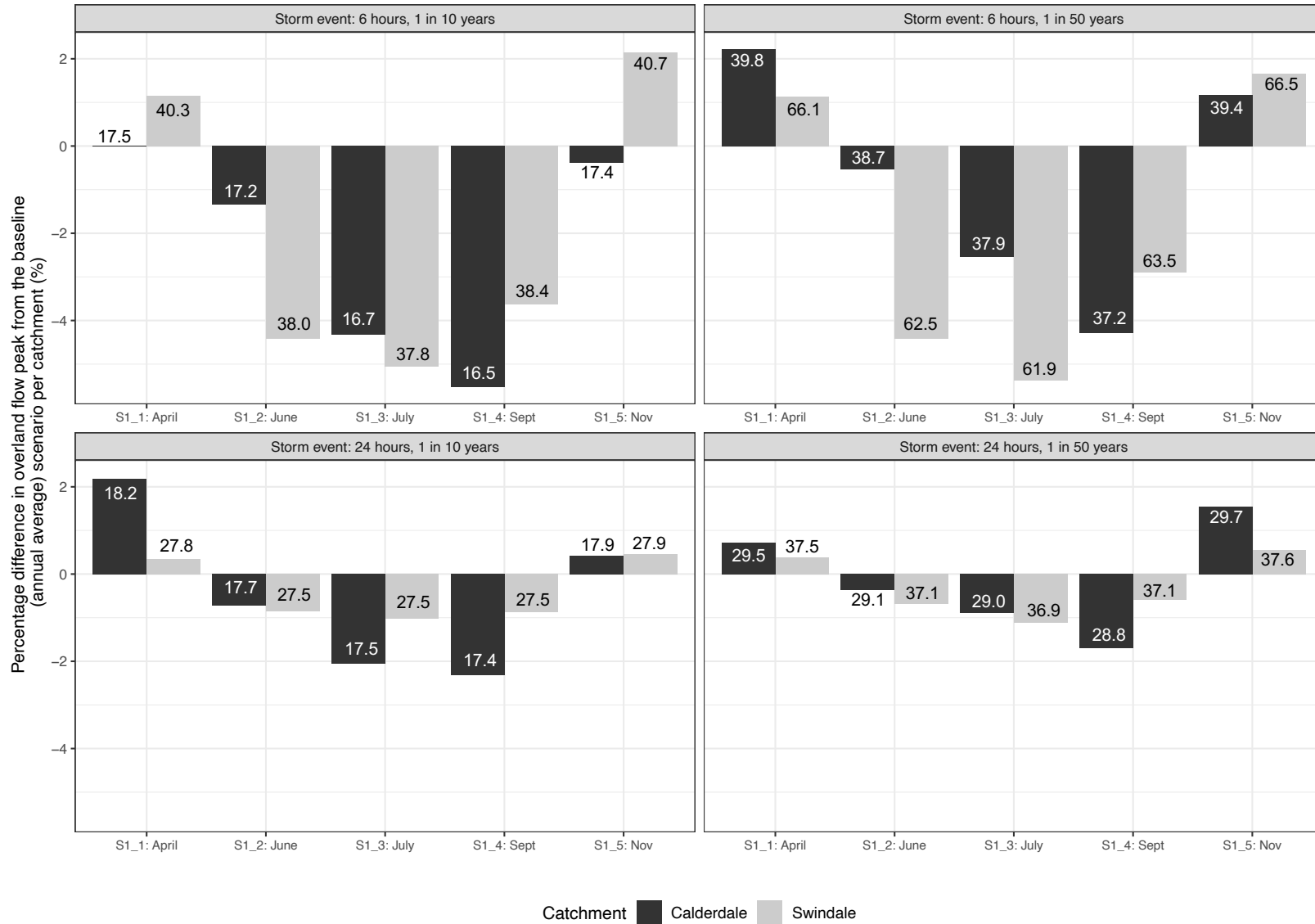

Figure 4.8: A comparison of the percentage difference in overland flow peak from the baseline (annual average) seasonality scenario for Swindale and Calderdale, with numbers inside each bar showing absolute peak overland flow,  $m^3s^{-1}$ . Baseline absolute peak overland flows for Swindale were  $39.8 m^3s^{-1}$  (6-hour, 1 in 10-year),  $65.4 m^3s^{-1}$  (6-hour, 1 in 50-year),  $27.7 m^3s^{-1}$  (24-hour, 1 in 10-year),  $37.4 m^3s^{-1}$  (24-hour, 1 in 50-year). Baseline absolute peak overland flows for Calderdale (seasonal scenario only) were  $17.5 m^3s^{-1}$  (6-hour, 1 in 10-year),  $38.9 m^3s^{-1}$  (6-hour, 1 in 50-year),  $17.8 m^3s^{-1}$  (24-hour, 1 in 10-year),  $29.3 m^3s^{-1}$  (24-hour, 1 in 50-year).

#### 4.4.2 Scenario set 2. Land management

Management also had a strong influence on flood peak and timing. The following results describe the modelled outcome for each scenario in Swindale (Figure 4.9), Calderdale (Figure 4.10) and the two catchments combined (Figure 4.11).

##### Swindale

Scenario S2\_1 increased overland flow peak (by 13.1 % ( $8.59 \text{ m}^3 \text{ s}^{-1}$ ; 6-hour 1 in 50-year) and 25.2 % ( $7.00 \text{ m}^3 \text{ s}^{-1}$ ; 24-hour, 1 in 10-year)) and total runoff peak (by between 1.0 % ( $0.57 \text{ m}^3 \text{ s}^{-1}$ ; 6-hour, 1 in 10-year) and 2.0 % ( $1.81 \text{ m}^3 \text{ s}^{-1}$ ; 6-hour, 1 in 50-year)) for all storm events. .

All other scenarios decreased overland flow and total runoff peaks compared to the baseline land cover (Figure 4.9, Appendix C5). Scenario S2\_2 was the most effective at reducing flow peaks with overland flow reduced by 13.5 % ( $5.03 \text{ m}^3 \text{ s}^{-1}$ ; 24-hour 1 in 50-year), 15.7 % ( $4.33 \text{ m}^3 \text{ s}^{-1}$ ; 24-hour 1 in 50-year), 21.5 % ( $14.04 \text{ m}^3 \text{ s}^{-1}$ ; 6-hour 1 in 50-year) and 24.2 % ( $9.62 \text{ m}^3 \text{ s}^{-1}$ ; 6-hour 1 in 10-year) (Figure 4.9). Total runoff peak was reduced by more in the 6-hour events than in the 24-hour events: 20.5 % ( $12.20 \text{ m}^3 \text{ s}^{-1}$ ; 6-hour, 1 in 10-year) and 17.1 % ( $15.26 \text{ m}^3 \text{ s}^{-1}$ ; 6-hour, 1 in 50-year) compared to 6.1 % ( $3.06 \text{ m}^3 \text{ s}^{-1}$ ; 1 in 10-year) and 4.8 % ( $3.03 \text{ m}^3 \text{ s}^{-1}$ ; 1 in 50-year). The next most effective management for reducing overland flow peak was S2\_5, 80% woodland, and this scenario was also more effective at reducing overland flow peak than S2\_2 for the 24-hour storms.

Scenarios S2\_3, S2\_4 and S2\_6 were similarly effective at reducing overland flow peaks, with reductions between 6.0 % (S2\_3: 6-hour 1 in 10-year,  $2.25 \text{ m}^3 \text{ s}^{-1}$ ) and 10.9 % (S2\_6: 6-hour 1 in 10-year,  $3.02 \text{ m}^3 \text{ s}^{-1}$ ). For these scenarios, storm duration did not influence percentage change from the baseline scenario, however management scenarios were more effective at flood peak reduction for the 1 in 10-year events (median overland flow peak reduction from baseline = 8.7 %) than the 1 in 50-year events (median overland flow peak reduction from baseline = 7.1 %).

Scenario S2\_2 delayed the total flow peak by 30 minutes in the 6-hour storms and 45 minutes in the 24-hour storms. In the 6-hour storms, no other scenario caused a delay in total runoff peak timing. In the 24-hour, 1 in 10-year storms, total peak was delayed by 15

minutes in scenarios S2\_3, S2\_4, S2\_5 and S2\_6. In the 24-hour, 1 in 50-year models, total runoff peak was delayed by 15 minutes in scenarios S2\_3 and S2\_4. For overland flow peak, delays of 15 minutes were modelled in the 6-hour, 1 in 10-year and 24-hour, 1 in 50-year events for S2\_3, S2\_4 and S2\_6. In the 6-hour, 1 in 50-year event, 15-minute delays were modelled for S2\_3 and S2\_4. With the exception of the 6-hour, 1 in 10-year event, overland flow peak runoff was 15 minutes earlier for scenario S2\_1.

### Calderdale

Only overland flow was modelled in Calderdale for the management scenarios (Figure 4.10). Response was similar to Swindale in that scenarios C2\_1 and 1a increased overland flow peaks for all storm events and all other scenarios decreased peak runoff. However, land management changes in Calderdale produced higher differences from the baseline model (Figure 4.9) when compared to Swindale. From the baseline model, overland flow peak in Calderdale increased by between 0.3 % ( $0.09 \text{ m}^3 \text{ s}^{-1}$ ; 24-hour, 1 in 50-year) and 5.9 % ( $1.03 \text{ m}^3 \text{ s}^{-1}$ ; 6-hour, 1 in 10-year) for C2\_1 and by between 15.3 % ( $6.01 \text{ m}^3 \text{ s}^{-1}$ ; 6-hour, 1 in 50-year) and 24.7 % ( $4.49 \text{ m}^3 \text{ s}^{-1}$ ; 24-hour, 1 in 10-year) for scenario C2\_1a.

Scenario C2\_5 was the most effective for all storm events; overland flow peak was reduced by 33.1 % ( $13.03 \text{ m}^3 \text{ s}^{-1}$ ; 6-hour, 1 in 50-year), 37.3 % ( $6.53 \text{ m}^3 \text{ s}^{-1}$ ; 6-hour, 1 in 10-year), 37.8 % ( $11.24 \text{ m}^3 \text{ s}^{-1}$ ; 24-hour, 1 in 50-year) and 41.0 % ( $7.45 \text{ m}^3 \text{ s}^{-1}$ ; 24-hour, 1 in 10-year). The next largest reductions in peak overland flow were for scenario C2\_2 followed by scenarios C2\_3 and C2\_4, and then scenario C2\_6 which still produced substantial overland flow peak reductions by between 18.4 % ( $7.24 \text{ m}^3 \text{ s}^{-1}$ ; 6-hour, 1 in 50) and 27.7 % ( $5.03 \text{ m}^3 \text{ s}^{-1}$ ; 24-hour, 1 in 10-year) (Appendix C5).

Peak timing was affected by management being up to 30-minutes earlier and later than for the baseline model. Scenarios C2\_1 and C2\_1a brought forward the overland flow peak in all storm events except scenario C2\_1 for the 24-hour, 1 in 10-year event, for which overland flow peaked at the same time as the baseline. In the 6-hour storm events (both C2\_1 and 1a), the 24-hour, 1 in 10-year event (C2\_1a) and the 24-hour, 1 in 50-year event (C2\_1), the overland flow peak was 15-minutes earlier than the baseline. Scenario C2\_1a peaked 30 minutes earlier than the baseline in the 24-hour, 1 in 50-year storm event. Delays

of 15 minutes occurred for scenarios C2\_2 and C2\_4 in the 6-hour, 1 in 10-year event. Scenarios C2\_3, C2\_4, C2\_5 and C2\_6 resulted in flow peaks that were delayed by 15 minutes, and, for C2\_2, by 30 minutes for the 24-hour, 1 in 10-year storm event. In the 24-hour, 1 in 50-year event, peak delays of 15 minutes were predicted for scenarios C2\_2 and C2\_5. There were no overland flow peak delays predicted for the 6-hour, 1 in 50-year event.

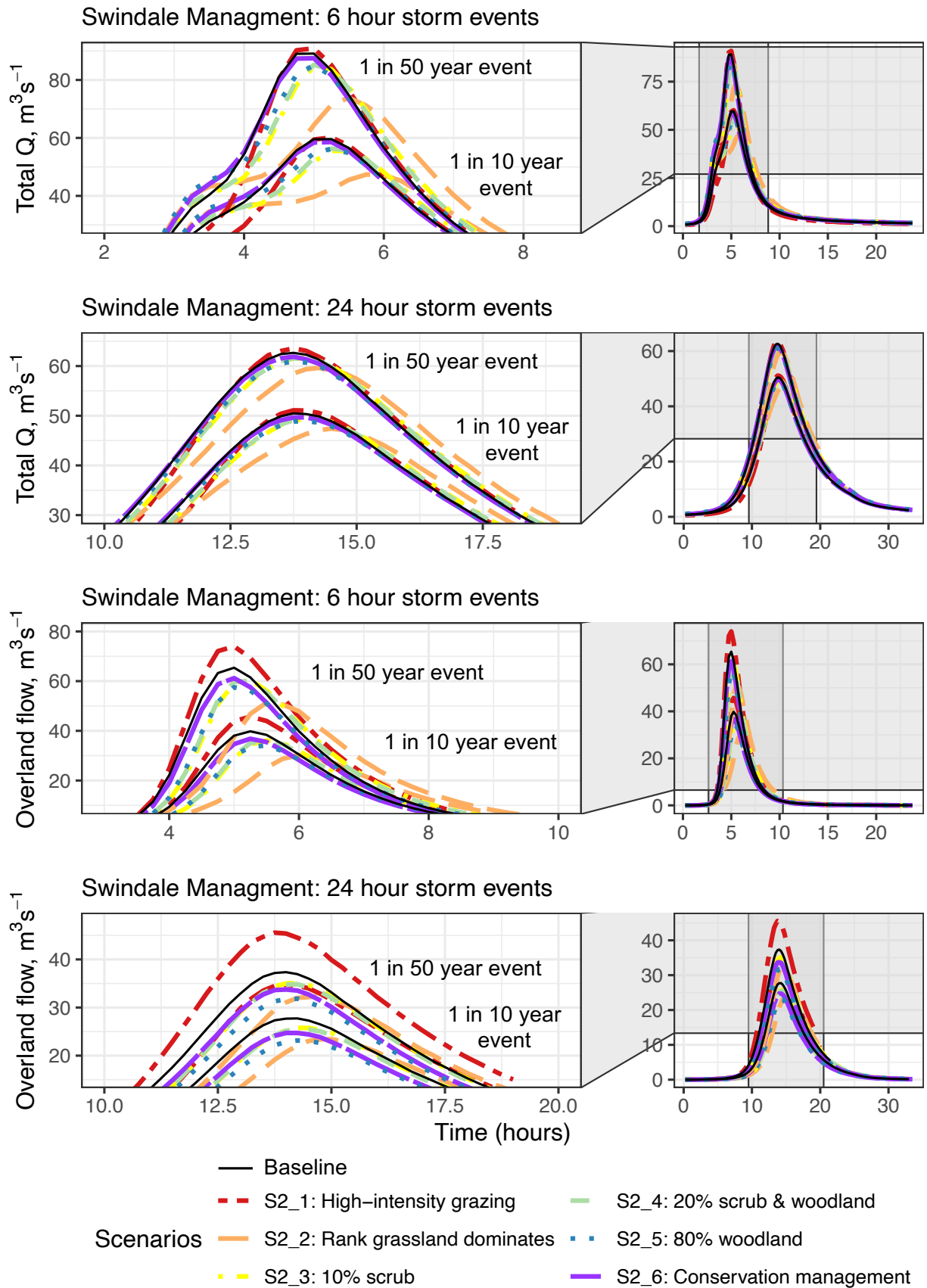

Figure 4.9: The influence of management on total runoff and overland flow peak and timing for ReFH storm events in Swindale. The black line represents the baseline model.

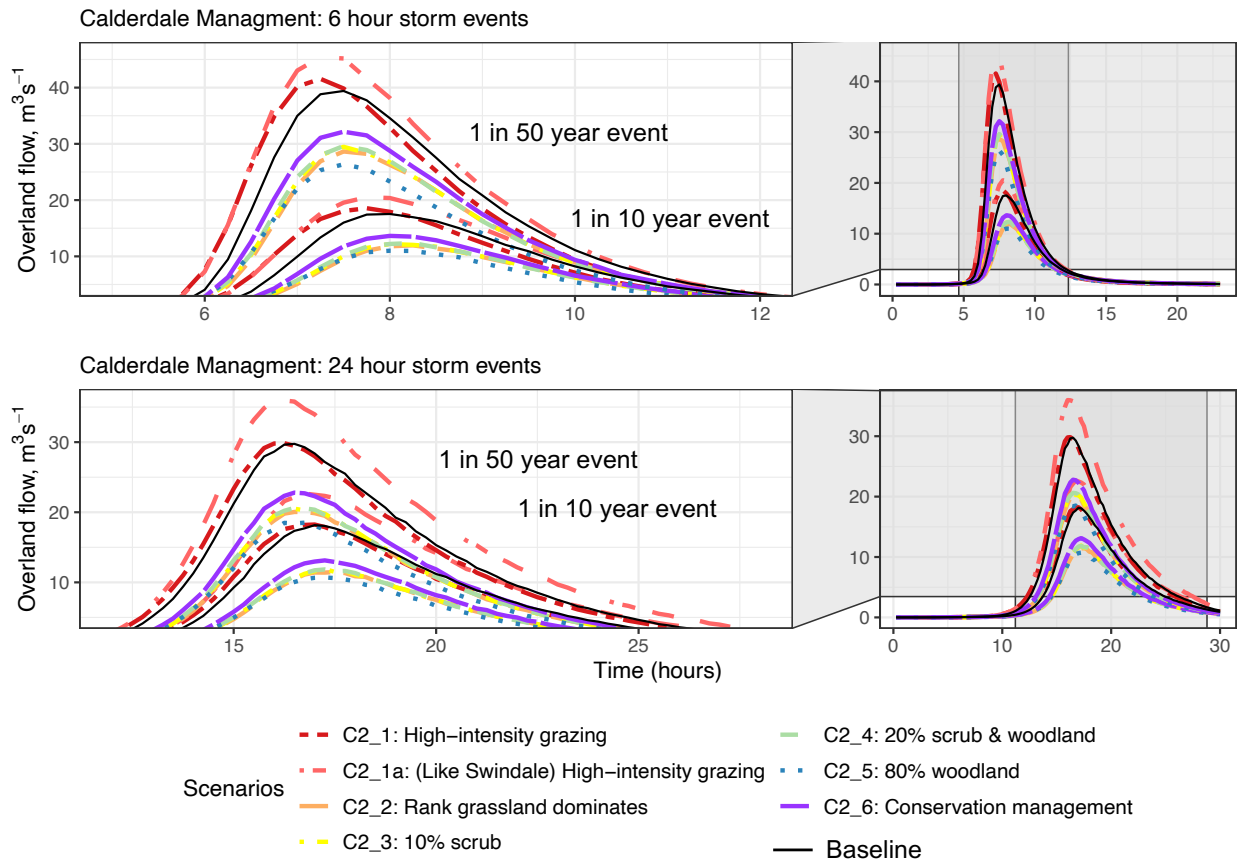

Figure 4.10: The influence of management on overland flow peak and timing for ReFH storm events in Calderdale. The black line represents the baseline model.

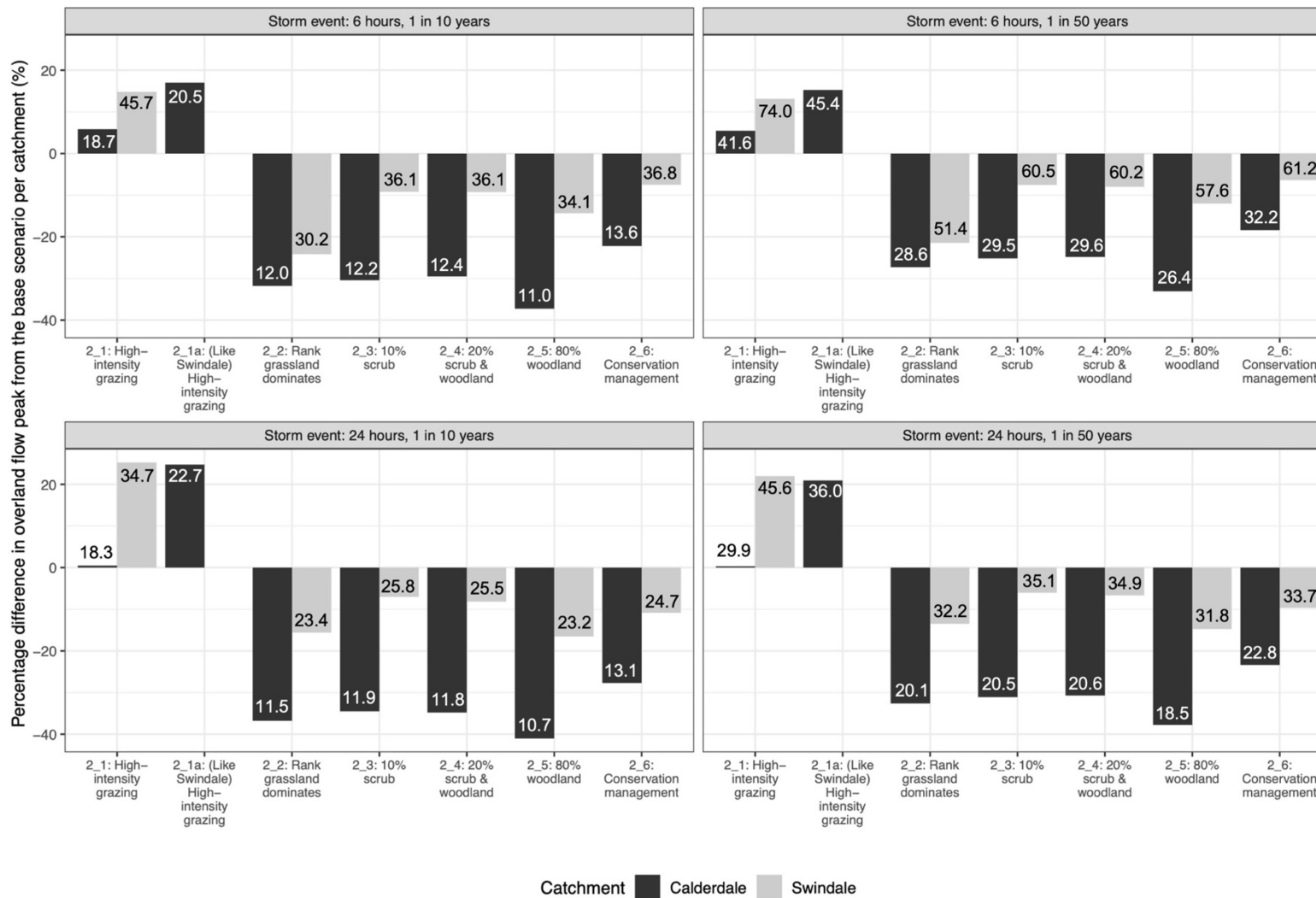

Figure 4.11: A comparison of the percentage difference in overland flow peak from the baseline (current land cover) management scenario for Swindale and Calderdale, with numbers inside each bar showing absolute peak overland flow,  $m^3s^{-1}$ . Baseline absolute peak overland flows for Swindale were  $39.8 m^3s^{-1}$  (6-hour, 1 in 10-year),  $65.4 m^3s^{-1}$  (6-hour, 1 in 50-year),  $27.7 m^3s^{-1}$  (24-hour, 1 in 10-year),  $37.4 m^3s^{-1}$  (24-hour, 1 in 50-year). Baseline absolute peak overland flows for Calderdale (management scenario only) were  $17.5 m^3s^{-1}$  (6-hour, 1 in 10-year),  $38.9 m^3s^{-1}$  (6-hour, 1 in 50-year),  $17.8 m^3s^{-1}$  (24-hour, 1 in 10-year),  $29.3 m^3s^{-1}$  (24-hour, 1 in 50-year).

## 4.5 Discussion

### 4.5.1 Surface roughness

Overall, seasonal changes in surface vegetation roughness and land cover distributions were shown to strongly influence total and overland flow peaks in response to storm events in two upland grassland-dominated systems. The variation in discharge peak and timing based on seasonal changes to vegetation growth, decay and management alone shows variation in catchment response which has not been modelled before. Both catchments responded similarly, with winter roughness, based on April and November field campaigns, producing the highest total and overland flow peaks, and summer roughness producing the lowest peaks. Only very small percentage changes were recorded in the baseflow, demonstrating that modelled response to different scenarios was overland flow driven.

Roughness is dependent on natural seasonal processes as well as seasonal management activities such as haymeadow cutting and livestock grazing density changes (Bond et al., 2020). Therefore, the influence of management and any changes to the vegetation species present should be considered in their seasonal context, especially with the increasing prevalence of winter flood events (Vormoor et al., 2015, Smith and Redding, 2012). In winter, interception and evapotranspiration are reduced in comparison to summer; therefore, saturation conditions are more likely to occur, inducing surface flows (Ledingham et al., 2019; Wallace and Chappell, 2020). Although model results showed overland flow peaks to be up to 2.2% higher than the annual average in winter, and winter roughness is generally lower than in summer, careful management might be used to minimise change in flood peaks. For example, understories of dense mosses, considered to be one of the most effective vegetation types for reducing flow velocity (Bond et al., 2020; Holden et al., 2008; Shuttleworth et al., 2019), might be encouraged to grow in source-areas of overland flow. Where overland flow is expected to be deeper (due to location or storm magnitude), taller, tussocky vegetation such as the Rank Grassland (for which immovable stems act as a barrier even in winter (Prosser et al., 1995)) might be used to intercept flow. Consideration should be given to all land cover types that may have appropriate structural characteristics. With the introduction of Future Farming Schemes, an opportunity is created to apply management, such as buffer strips, that considers location and seasonality. Future



hydrological modelling should also account for the (often opposing) influence of seasonal storms and roughness, especially when forecasting NFM impacts. If possible, models should also incorporate varying antecedent conditions to simulate seasonal change in soil moisture which influences available water storage and associated probability of overland flow occurrence.

The strong effect of vegetative roughness was also shown in the management scenario simulation, alongside permeability and interception. Woodland has been found to have lower surface roughness (the ground level understory of woodlands can be shaded out and is not dense) and higher permeability than grassland (Bond et al., 2021; Bond et al., 2020; Monger et al., 2022). In Swindale, scenario 2\_2 reduced overland flow and total flow peaks by up to 24.2 % and 20.5 % respectively. As scrub and woodland were added in other scenarios, flood peaks increased despite increased permeability and interception. This suggests that the added water infiltration and canopy storage benefits were not enough to outweigh the decrease in vegetative roughness. This matches the hypothesis presented by Bond et al. (2020) who suggested that the density of vegetation at ground level was the most important factor in influencing upland hillslope runoff, especially where shallow soils dominate as they do in both Swindale and Calderdale. Where overland flow dominates (Bond et al. (2021) showed that overland flow can occur up to 60% of the time in Swindale), roughness becomes the primary control of hillslope runoff contribution to the hydrograph. Therefore, in catchments such as Swindale, management which works towards soil aeration for increased storage may be less important for flood mitigation than management which aims to control hillslope runoff through increased surface friction.

Conversely, when modelling overland flow only in Calderdale and in the 24-hour Swindale models, scenario 2\_5 with 80% woodland cover produced the most effective flood mitigation. Given this, the increased permeability and interception are likely to be more influential factors for overland flow management in Calderdale and the 24-hour Swindale storms. However, there may be a threshold at which the extent of influence occurs (Smith and Redding, 2012). For example, within each catchment and per storm event, scenarios 2\_3 and 2\_4 produced very similar responses to each other despite the 10% increase in scrub and woodland cover. In addition, only scenario 2\_5 was more effective than scenario

2\_2 suggesting that for most practical changes in management, ground-level roughness may be the most important factor. However, seasonality may also influence the extent to which roughness, permeability and interception affect flow peaks where annual average  $K_v$  and winter  $I_n$  parameters were used within the management scenarios. In summer, any existing threshold may be different to in winter, potentially affecting flow peaks and timing; future research should investigate this. Unfortunately, our research cannot differentiate between the influence of permeability and interception as both change proportionally with the addition of woodland and scrub. However, the overall influence of roughness compared to permeability alongside interception may occur for a variety of reasons, as discussed below.

#### 4.5.2 Topography

The difference in topography between catchments may influence the extent to which  $K$  and  $K_v$  parameters are influential and explain why April produced the highest overland flow peak in Swindale compared to November in Calderdale. On steeper slopes, roughness is less able to reduce downslope overland flow velocity (Maske and Jain, 2014); with increased permeability, water may infiltrate soils but also be subject to increased sub-surface lateral flows (Dunne, 1978). Topography may also explain why the 24-hour models in Swindale produced lower overland flow peaks for scenario 2\_5 than 2\_2; with lower rainfall intensity and longer duration, infiltration-excess overland flow was less likely to occur, thus permeability outweighed the influence of roughness.

#### 4.5.3 Data resolution

Due to land cover data availability and catchment size (which limits model processing power), land cover resolution in Swindale (5m cells) was much greater than that of Calderdale (20 m cells). This may influence runoff pathways and the relative contributions of land cover types. For example, road cover is relatively sparse in the catchments modelled, however asphalt surfaces are known to act as conduits of water in storm events (Hollis, 1988); due to the relatively small size of surfaces such as this, their impact may not have been accounted for properly in the lower resolution Calderdale model. The difference in data resolution may limit comparison between catchments.

#### 4.5.4 Availability of soil hydrology data

SD-TOPMODEL parameters for Calderdale were predominately based on fieldwork from Swindale and its neighbouring catchment, the Naddle valley. Ideally, catchment parameters would always be specific to the location modelled, especially where the intensity of management differs. At the very least, a collated database of soil and vegetation hydrological properties is needed to provide options from which hydrologists can make informed parameter decisions. This is especially true for woodland data, where our fieldwork and subsequent modelling has shown rank grassland can be more effective than woodland for reducing overland flow; especially where roughness data traditionally used for modelling, such as that by Chow (1959), show woodland as the rougher land cover. Further fieldwork is required to determine whether this is Swindale-specific (since most *K<sub>v</sub>* data were from Swindale and its neighbouring catchment), or a common error that propagates from the assumptions through into model outputs, especially since ‘woodland’ is a wide category for which there may be much variation in understorey vegetative roughness. In addition, the influence of roughness, permeability and interception change with scrub and woodland growth over time was not modelled due to a lack of available empirical data; future research into the effect of land cover change on hydrological properties over time is required. Finally, further work is also required to understand how surface roughness and slope combine to influence overland flow to ensure that numerical schemes of models are based on empirical data, rather than previous assumptions.

#### 4.5.5 Implications for NFM planning

Worldwide, high intensity grazing is frequently associated with higher flood peaks caused by soil compaction and low roughness as the result of overgrazing (Ochoa-Tocachi et al., 2016, Alaoui et al., 2018). Conversely, nature friendly farming and conservation management often involves reducing grazing intensity (English Nature, 2005). In our catchments, overland flow peaks were substantially reduced when such strategies were modelled. This supports evidence (Burgess-Gamble et al., 2017; Nature Friendly Farming Network, 2021) that NFM methods adopted in conjunction with sustainable, nature-based farming, such as those

proposed in the new UK Future Farming Schemes (Defra, 2021b, 2022b), can work to reduce flood risk significantly.

In both catchments, interventions were applied to grazed grasslands only, also excluding the commons grazing in Swindale, except for changes made as part of scenario 2\_1 and 2\_1a. In terms of catchment area, interventions applied in Swindale covered 9.2% of the catchment (1.41 km<sup>2</sup>; 6.64 km<sup>2</sup> (43.4 %) of the catchment for scenario 2\_1) and interventions in Calderdale covered 27.5 % of the catchment (5.75 km<sup>2</sup>; 15.10 km<sup>2</sup> (70.3 %) of the catchment for scenario 2\_1a). Whether policy-makers and land managers can apply interventions over such large proportions of upland catchments remains to be seen, but considering the area to which interventions were applied, and that interventions were applied to grasslands only, the reductions in overland flow peak are important and add to the much needed evidence base on NFM (Burgess-Gamble et al., 2017; Dadson et al., 2017).

The placement of NFM appears to be important. In Swindale, interventions were applied in the riparian and near-stream hillslope zones close to the catchment outlet, whereas in Calderdale, interventions were mainly hillslope based in the mid-catchment. Despite Swindale interventions covering 18.3 % less catchment area than Calderdale, percentage change in overland flow peak was on average just 16.0 % less. For historical grazing, this difference was even greater, where a catchment area difference of 26.9 % produced just a 2.2% difference in overland flow peak. The differences between catchment area and response, and the likely influence of NFM placement, supports research by Gao et al. (2016) who showed that modelled landcover changes in the riparian zone could have three times more influence on flow peaks than changes made in upper hillslope locations.

## 4.6 Conclusion

Seasonal change in ground vegetation roughness, and management changes to upland catchments can have substantial influence on runoff, especially overland flow. We showed that seasonal changes in vegetation roughness alone can reduce overland flow peaks by up to 5.5 % at the catchment scale, demonstrating the importance of considering the nature of surface vegetation cover at different times of the year. In addition to vegetation and soil

roughness, flow can also be initially slowed via infiltration before saturation conditions, where subsurface flow velocity is generally lower than for surface runoff. When considering NFM effectiveness, seasonal surface roughness should be considered, and this could be particularly important during winter months when roughness, interception and evapotranspiration are reduced.

Land cover management is also important for controlling runoff through its influence to infiltration rates and surface roughness, with overland flow peaks reduced by up to 41.0 % from the baseline scenario. Our research showed the greatest reduction in discharge peaks was associated with two management scenarios: 80% woodland cover, and conversion of grazed grasslands to rank grassland. Surface roughness and permeability are both important factors to consider when implementing NFM. However, factors such as topography and NFM placement can also affect runoff control; these physical characteristics were hypothesised to be the primary cause of difference between catchments, influencing the extent of control provided by roughness and permeability. Where overland flow dominates, surface roughness is likely to be more influential on runoff control than permeability, especially for shallow soils. On a practical basis, most catchments cannot be converted to 80 % woodland cover and therefore ground-level roughness should be strongly considered. Conservation practices which combine NFM with nature friendly farming might therefore be deemed very effective, providing a potential practical compromise between economic output, conservation and NFM.

## 4.7 References

- Alaoui, A., Rogger, M., Peth, S., & Blöschl, G. (2018). Does soil compaction increase floods? A review. *Journal of Hydrology*, 557, 631-642.
- Amjid, M. 2017. Calderdale Section 19 Report: Flood events of November and December 2015. Halifax: Calderdale Metropolitan Borough Council.
- Beven, K., & Kirkby, M. (1979). A physically based, variable contributing area model of basin hydrology/Un modèle à base physique de zone d'appel variable de l'hydrologie du bassin versant. *Hydrological Sciences Journal*, 24(1), 43-69.
- Blyth, E. M., Martinez-de la Torre, A., & Robinson, E. L. (2019). Trends in evapotranspiration and its drivers in Great Britain: 1961 to 2015. *Progress in Physical Geography: Earth and Environment*, 43(5), 666-693.
- Boisgontier, H. (2018). *Modelling the potential of natural flood management practices in an upland peatland catchment with the distributed TOPMODEL*. (Research Report), EPFL, Lausanne.
- Bol, R., Blackwell, M., Emmett, B., Reynolds, B., Hall, J., Bhogal, A., & Ritz, K. (2011). *Assessment of the response of organo-mineral soils to change in management practices*. Sub-Project ii of Defra Project SP1106: Soil carbon: studies to explore greenhouse gas emissions and mitigation. DEFRA
- Bond, S., Kirkby, M. J., & Holden, J. (2021). Upland grassland management influences organo-mineral soil properties and their hydrological function. *Ecohydrology*, e2336.
- Bond, S., Kirkby, M. J., Johnston, J., Crowle, A., & Holden, J. (2020). Seasonal vegetation and management influence overland flow velocity and roughness in upland grasslands. *Hydrological Processes*, 34(18), 3777-3791.
- Branham, J. E., & Strack, M. (2014). Saturated hydraulic conductivity in Sphagnum-dominated peatlands: do microforms matter? *Hydrological Processes*, 28(14), 4352-4362.
- Burgess-Gamble, L., Ngai, R., Wilkinson, M., Nisbet, T., Pontee, N., Harvey, R., . . . Quinn, P. (2017). *Working with natural processes to reduce flood risk*. Bristol, UK: Environment Agency.
- Burt, T., & Holden, J. (2010). Changing temperature and rainfall gradients in the British Uplands. *Climate Research*, 45, 57-70.
- Carrick, J., Abdul Rahim, M. S. A. B., Adjei, C., Ashraa Kalee, H. H. H., Banks, S. J., Bolam, F. C., . . . Domingos, I. F. N. (2019). Is planting trees the solution to reducing flood risks? *Journal of Flood Risk Management*, 12(S2), e12484.
- CEH. (2017). Centre for Ecology and Hydrology (CEH) LandCoverMap2015 (LCM2015). Dataset documentation. Version 1.2, 22nd May 2017
- Chan, F. K. S., Griffiths, J. A., Higgitt, D., Xu, S., Zhu, F., Tang, Y.-T., . . . Thorne, C. R. (2018). "Sponge City" in China—A breakthrough of planning and flood risk management in the urban context. *Land Use Policy*, 76, 772-778.
- Chow, V. T. (1959). Open-channel hydraulics. In *Open-channel hydraulics*. McGraw-Hill.
- Cranfield University. (2022). The Soils Guide [online]. Available at: [www.landis.org.uk](http://www.landis.org.uk) [Accessed 27/01/2022]
- Dadson, S. J., Hall, J. W., Murgatroyd, A., Acreman, M., Bates, P., Beven, K., . . . Lane, S. N. (2017). A restatement of the natural science evidence concerning catchment-based

- 'natural' flood management in the UK. *Proceedings of the Royal Society A: Mathematical, Physical and Engineering Sciences*, 473(2199), 20160706.
- Defra. (2016). *Key results by UK country: 1866 to 2016 [online]*. London: DEFRA. Available at: <https://www.gov.uk/government/statistical-data-sets/structure-of-the-agricultural-industry-in-england-and-the-uk-at-june>. [Accessed 25/01/2022]
- Defra. (2021a). Calder from Source to Walsden Water Water Body. Available at: <https://environment.data.gov.uk/catchment-planning/WaterBody/GB104027062660>. [Accessed 25/01/2022]
- Defra. (2021b). The new Sustainable Farming Incentive. *Future Farming*. Available at: <https://defrafarming.blog.gov.uk/2021/02/23/the-new-sustainable-farming-incentive/> [Accessed 15/02/2022]
- Defra. (2022a). Landscape Recovery: more information on how the scheme will work. *Policy Paper*. Available at: <https://www.gov.uk/government/publications/landscape-recovery-more-information-on-how-the-scheme-will-work/landscape-recovery-more-information-on-how-the-scheme-will-work> [Accessed 15/02/2022]
- Defra. (2022b). Local Nature Recovery: more information on how the scheme will work. *Policy Paper*. Available at: <https://www.gov.uk/government/publications/local-nature-recovery-more-information-on-how-the-scheme-will-work/local-nature-recovery-more-information-on-how-the-scheme-will-work> [Accessed 15/02/2022]
- Defra, & Coffey, T. (2017). Schemes across the country to receive £15 million of natural flood management funding [Press release]. Available at: <https://www.gov.uk/government/news/schemes-across-the-country-to-receive-15-million-of-natural-flood-management-funding> [Accessed 15/02/2022]
- Dunne, T. (1978). Field studies of hillslope flow processes. In M. J. Kirkby (Ed.), *Hillslope hydrology* (pp. 227-293). John Wiley & Sons: Chichester, UK
- Ellis, N., Anderson, K., & Brazier, R. (2021). Mainstreaming natural flood management: A proposed research framework derived from a critical evaluation of current knowledge. *Progress in Physical Geography: Earth and Environment*, 0309133321997299.
- English Nature. (2005). *The importance of livestock grazing for wildlife conservation*. Retrieved from <http://www.englishnature.org.uk/pubs/publication/PDF/LivestockGrazing.pdf>. English Nature
- Forestry Commission. (2016). Standard and Guidance. Eligible Activities - Soil type. Available at: <https://www.forestry.gov.uk/forestry/INFD-8J3QRL> [Accessed 07/02/2022]
- Gao, J., Holden, J., & Kirkby, M. (2015). A distributed TOPMODEL for modelling impacts of land-cover change on river flow in upland peatland catchments. *Hydrological Processes*, 29(13), 2867-2879.
- Gao, J., Holden, J., & Kirkby, M. (2016). The impact of land-cover change on flood peaks in peatland basins. *Water Resources Research*, 52(5), 3477-3492.
- Gash, J., Wright, I., & Lloyd, C. R. (1980). Comparative estimates of interception loss from three coniferous forests in Great Britain. *Journal of Hydrology*, 48(1-2), 89-105.
- Greenwood, K., & McKenzie, B. (2001). Grazing effects on soil physical properties and the consequences for pastures: a review. *Australian Journal of Experimental Agriculture*, 41(8), 1231-1250.

- Herbst, M., Roberts, J. M., Rosier, P. T., & Gowing, D. J. (2006). Measuring and modelling the rainfall interception loss by hedgerows in southern England. *Agricultural and Forest Meteorology*, *141*(2-4), 244-256.
- Herbst, M., Rosier, P. T., McNeil, D. D., Harding, R. J., & Gowing, D. J. (2008). Seasonal variability of interception evaporation from the canopy of a mixed deciduous forest. *Agricultural and Forest Meteorology*, *148*(11), 1655-1667.
- Holden, J., & Burt, T. P. (2003). Runoff production in blanket peat covered catchments. *Water Resources Research*, *39*(7).
- Holden, J., Chapman, P., Evans, M., Hubacek, K., Kay, P., & Warburton, J. (2007). Vulnerability of organic soils in England and Wales. Final technical report to DEFRA and Countryside Council for Wales. DEFRA Project SP0532. London: DEFRA.
- Holden, J., Kirkby, M. J., Lane, S. N., Milledge, D. G., Brookes, C. J., Holden, V., & McDonald, A. T. (2008). Overland flow velocity and roughness properties in peatlands. *Water Resources Research*, *44*(6).
- Holden, J., Shotbolt, L., Bonn, A., Burt, T., Chapman, P., Dougill, A., . . . Kirkby, M. (2007). Environmental change in moorland landscapes. *Earth-Science Reviews*, *82*(1-2), 75-100.
- Hollis, G. (1988). Rain, roads, roofs and runoff: hydrology in cities. *Geography*, *73*(1), 9-18.
- Joint Nature Conservation Committee. (2011). *Towards an assessment of the state of UK Peatlands. JNCC report 445. ISSN 0963 8901*. Available at: <http://jncc.defra.gov.uk/page-5861> [Accessed 15/12/2021]
- Kingsbury-Smith, L. E. (2019). *Testing the effectiveness of land use management as a natural flood management technique*. (Masters by Research), University of Leeds.
- Kjeldsen, T., Stewart, E., Packman, J., Folwell, S., & Bayliss, A. (2005). *Revitalisation of the FSR/FEH rainfall-runoff method*. CEH, Wallingford.
- Kottek, M., Grieser, J., Beck, C., Rudolf, B., & Rubel, F. (2006). World map of the Köppen-Geiger climate classification updated. *Meteorologische Zeitschrift*, *15*(3), 259-263.
- Ledingham, J., Archer, D., Lewis, E., Fowler, H., & Kilsby, C. (2019). Contrasting seasonality of storm rainfall and flood runoff in the UK and some implications for rainfall-runoff methods of flood estimation. *Hydrology Research*, *50*(5), 1309-1323.
- Lowe, J. A., Bernie, D., Bett, P., Bricheno, L., Brown, S., Calvert, D., . . . Fosser, G. (2018). *UKCP18 science overview report*. Met Office Hadley Centre: Exeter, UK.
- Maske, S. P., & Jain, M. K. (2014). Study on effect of surface roughness on overland flow from different geometric surfaces through numerical simulation. *Hydrological Processes*, *28*(4), 2595-2616.
- Met Office. (2020). UK Climate averages: Shap weather station 1981-2010 [online]. Available at: <https://www.metoffice.gov.uk/research/climate/maps-and-data/uk-climate-averages/gcwn4cte6> [Accessed 09/01/2020]
- Met Office. (2021). *UK Climate Projections: Headline Findings (Version 3, July 2021)*. Exeter, UK: Met Office Hadley Centre.
- Meyles, E., Williams, A., Ternan, J., Anderson, J., & Dowd, J. (2006). The influence of grazing on vegetation, soil properties and stream discharge in a small Dartmoor catchment, southwest England, UK. *Earth Surface Processes and Landforms*, *31*(5), 622-631.
- Monger, F., Bond, S., Spracklen, D., & Kirkby, M. (2022). Overland flow velocity and soil properties in established semi-natural woodland and wood pasture in an upland catchment. *Hydrological Processes*, e14567.



- Morton, D., Rowland, C., Wood, C., Meek, L., Marston, C., Smith, G., . . . Simpson, I. (2011). *Final report for LCM2007-the new UK land cover map. Countryside survey technical report no 11/07*. Lancaster, UK: NERC/Centre for Ecology & Hydrology (CEH Project Number: C03259).
- National Audit Office. (2020). *Managing flood risk*. HC 962. Available at: <https://www.nao.org.uk/report/managing-flood-risk/>: [Accessed 15/02/2022]
- Natural England. (2012). *Higher Level Stewardship. Environmental Stewardship Handbook. Fourth edition - January 2013*. Available at: <http://publications.naturalengland.org.uk/publication/2827091> [Accessed 09/01/2020]
- Nature Friendly Farming Network. (2021). *NFFN Evidence; Nature Friendly Farming for The Committee for Agriculture, Environment and Rural Affairs (AERA) 16th April 2021*. Available at: <http://www.niassembly.gov.uk/globalassets/committee-blocks/agriculture-environment-and-rural-affairs/2017---2022/new-folder/nature-friendly-farming/nffn-written-briefing---nature-friendly-farming.pdf>: <http://www.niassembly.gov.uk/globalassets/committee-blocks/agriculture-environment-and-rural-affairs/2017---2022/new-folder/nature-friendly-farming/nffn-written-briefing---nature-friendly-farming.pdf> [Accessed 15/02/2022]
- Ochoa-Tocachi, B. F., Buytaert, W., De Bievre, B., Célleri, R., Crespo, P., Villacís, M., . . . Guallpa, M. (2016). Impacts of land use on the hydrological response of tropical Andean catchments. *Hydrological Processes*, 30(22), 4074-4089.
- Priestley, S. (2017). *Flood risk management and funding*. Briefing Paper CBP07514. House of Commons Library: London, UK.
- Prosser, I. P., Dietrich, W. E., & Stevenson, J. (1995). Flow resistance and sediment transport by concentrated overland flow in a grassland valley. *Geomorphology*, 13(1-4), 71-86.
- Rogger, M., Agnoletti, M., Alaoui, A., Bathurst, J., Bodner, G., Borga, M., . . . Hall, J. (2017). Land-use change impacts on floods at the catchment scale—Challenges and opportunities for future research. *Water Resources Research*, 53(7), 5209-5219.
- Shuttleworth, E. L., Evans, M. G., Pilkington, M., Spencer, T., Walker, J., Milledge, D., & Allott, T. E. (2019). Restoration of blanket peat moorland delays stormflow from hillslopes and reduces peak discharge. *Journal of Hydrology X*, 2, 100006.
- Smith, P., Smith, J., Flynn, H., Killham, K., Rangel-Castro, I., Foereid, B., . . . Bell, J. (2007). *ECOSSE: Estimating carbon in organic soils-sequestration and emissions* (0755914988). Scottish Executive Environment and Rural Affairs Department: Edinburgh.
- Smith, R., & Redding, T. (2012). Cumulative effects assessment: Runoff generation in snowmelt-dominated montane and boreal plain catchments. *Streamline Watershed Management Bulletin*, 15(1), 24-34.
- Vormoor, K., Lawrence, D., Heistermann, M., & Bronstert, A. (2015). Climate change impacts on the seasonality and generation processes of floods—projections and uncertainties for catchments with mixed snowmelt/rainfall regimes. *Hydrology and Earth System Sciences*, 19(2), 913-931.
- Wallace, E. E., & Chappell, N. A. (2020). A statistical comparison of spatio-temporal surface moisture patterns beneath a semi-natural grassland and permanent pasture: From drought to saturation. *Hydrological Processes*, 34(13), 3000-3020.
- WG POM. (2014). *EU policy document on Natural Water Retention Measures*. Technical Report-2014-082. Prepared by the drafting team of the Water Framework Directive

- Common Implementation Strategy Working Group Programme of measures (WG PoM). Office for Official Publications of the European Communities: Luxembourg
- Willis, T. D., & Klaar, M. J. (2021). *NFM Calderdale Summary Modelling Report*. Available at: <https://icasp.org.uk/projects-2-2/calderdale-nfm-2/>: iCASP. [Accessed 16/02/2022]
- Wood, S., Sebastian, K., & Scherr, S. J. (2000). *Agroecosystems*. Pilot analysis of global ecosystems. Washington, DC, USA: International Food Policy Research Institute and World Resources Institute.
- Xu, J., Morris, P. J., Liu, J., & Holden, J. (2018). PEATMAP: Refining estimates of global peatland distribution based on a meta-analysis. *Catena*, *160*, 134-140.
- Zhao, Y. (2008). *Livestock impacts on hydrological connectivity*. (PhD thesis), University of Leeds.

## Chapter 5. Synthesis and conclusions

As the occurrence of extreme weather events and associated flooding increases worldwide with climate change (Lowe et al., 2018), it is essential that the mechanisms surrounding runoff generation are better understood so that landscapes can be managed effectively for flood mitigation (Forbes et al., 2015). In the UK, uplands are key source areas for flooding events but also have a high potential for NFM applications (Burgess-Gamble et al., 2017). Very little is known globally about the hydrological function of upland organo-mineral (OM) soils and their associated grasslands. However, OM soil grasslands are a potentially important land use on which flood mitigation efforts might occur, and previous research has found management of livestock and vegetation to have an important influence on runoff production (Holden et al., 2008, Meyles et al., 2006, Marshall et al., 2009, Clarke et al., 2008). The overarching aim of this research was to characterise runoff in upland grasslands underlain by OM soils and investigate differences related to grazing and cutting management. Implications for flood management at the catchment scale were also considered. Fieldwork was undertaken in Swindale, Lake District, UK, with modelling building on that fieldwork but also expanded to Calderdale, Yorkshire UK.

The original research questions are as follows:

- 1) To what extent does land management affect OM soil properties and their associated hydrology?**
- 2) To what extent does vegetation cover of upland OM soils influence surface roughness and its associated overland flow velocity?**
- 3) How does management on upland OM soils influence downstream discharge peak magnitude and timing?**

Below is a summary of the key conclusions from each of the three results chapters addressing the research questions above.

## 5.1 Chapter summaries and section outline

**Chapter Two: Upland grassland management influences organo-mineral soil properties and their hydrological function.** A paired plot comparison study was undertaken comparing soil properties, overland flow occurrence and soil moisture for grazed and ungrazed grasslands at two different elevations. Overland flow was found to occur up to 60 % of the time and for longer durations in the grassland excluded from grazing. Soil moisture varied significantly between habitats, but no soil moisture threshold at which overland flow occurred was found. Soil properties varied significantly between grassland types. Saturated hydraulic conductivity,  $K_s$ , averaged  $2.4 \text{ m day}^{-1}$  but ranged across several orders of magnitude from  $1.3 \times 10^{-3}$  to  $1.5 \times 10^2 \text{ m day}^{-1}$ . Due to the shallow soils and high  $K_s$ , saturation excess overland flow was determined to be the likely primary driver of river storm flow.

**Chapter Three: Seasonal vegetation and management influence overland flow velocity and roughness in upland grasslands.** A novel portable hillslope flume was developed to measure overland flow velocity within four commonly occurring grassland types: Low-density grazing, Hay meadow, Rank Grassland and *Juncus effusus* Rush pasture. Data were collected throughout the year for three different flow rates –  $12 \text{ L min}^{-1}$ ,  $6 \text{ L min}^{-1}$  and  $1.2 \text{ L min}^{-1}$  – observing changes to velocity as the result of seasonal growth, decay, and management. At the  $12 \text{ L min}^{-1}$  flow rate, Rank Grassland generally had the lowest mean overland flow velocity ( $0.026 \text{ m s}^{-1}$ ) followed by Low-density grazing and Rushes ( $0.032$  and  $0.029 \text{ m s}^{-1}$ ), then Hay Meadows ( $0.041 \text{ m s}^{-1}$ ). Using these values, over a 100 m theoretical hillslope, overland flow could be delayed by 24 minutes longer in Rank Grassland compared to Hay Meadows for an 18 mm storm event. On a seasonal basis, overland flow velocity is affected by growth and decay in addition to grazing and cutting management. Winter overland flow velocities were significantly higher than in summer, varying between  $0.004 \text{ m s}^{-1}$  (Rushes, November) and  $0.034 \text{ m s}^{-1}$  (Rushes, June). Velocities also significantly increased after cutting, varying between  $0.006 \text{ m s}^{-1}$  (Hay meadows, July) and  $0.054 \text{ m s}^{-1}$  (Hay meadows, September). Chapter Three concluded that surface roughness was a strong modifier of overland flow velocity which should be incorporated into hydrological modelling

and NFM planning. A discussion regarding traditional measures of roughness concluded that Darcy-Weisbach greatly over-estimated measured flow velocity.

**Chapter Four: The influence of land management and season on flood mitigation in two UK upland catchments.** The effect of season and management of grasslands was modelled for Swindale and Calderdale, analysing influence over runoff and timing. Empirically based data was used for all scenarios. The first scenario investigated change in vegetative roughness with season, quantifying the influence of roughness on ‘slowing the flow’ at the catchment scale. The second scenario investigated changes in management from historical high-intensity grazing to a series of natural succession stages between grassland and woodland, and conservation-based management. Seasonal changes to vegetation were found to affect overland flow peaks by up to +2.2 % in winter and -5.5 % in summer. Changes to hillslope grassland management reduced overland flow peaks by up to 41.0 % in Calderdale, where extensive woodland development was the most effective scenario, and up to 34.5 % in Swindale, where a rank grassland dominated catchment was the most effective. Conservation management reduced overland flow peak by up to 42.0 % compared to the high intensity grazing scenario. Neither management nor seasonality had significant influence on the timing of runoff peaks. Chapter Four concluded that, where overland flow dominates, especially in catchments with shallow soils, surface roughness was found to be more influential than soil permeability for flood mitigation. It was recommended that seasonal changes to roughness are considered alongside practicalities of NFM in mosaiced upland catchments.

**Chapter Five: Synthesis and conclusions.** This chapter ties together the previous chapters, discussing their relationships to the original research questions and wider literature, and how outcomes from each chapter can be used to benefit flood mitigation. Four primary themes are discussed below: 1) The role of land management on subsurface hydrology, and 2) on surface hydrology; 3) the influence of seasonality on runoff generation and control; 4) the key implications for NFM. Following this, limitations of the work are examined and suggestions for future research are given, ending with a concluding statement.

## 5.2 The influence of land management on subsurface hydrology

### 5.2.1 Management drivers of subsurface hydrology

Prior to this research, very little data existed regarding OM soil hydrological function. It was unknown how regularly OM soils produce overland flow and through what mechanism. Chapter Two found saturation excess overland flow to be a dominant flow mechanism, present up to 60% of the time, driven primarily by physical catchment characteristics as opposed to management influences. This was evidenced in Chapter Two where soils were found to be very freely draining, with a high  $K_s$ , and although significant differences were measured between grassland types, there was no grouping between grazed and ungrazed portions of the hillslope. Given grazing has often been shown to influence soil hydrology by reducing infiltration rates through compaction (Meyles et al., 2006, Clarke et al., 2008, Marshall et al., 2014), the lack of grouping by soil properties and moisture in Swindale suggests that the low-density grazing may not have been impactful enough to alter flow mechanisms in the surface horizon. This directly contrasts with nearby (Lowther catchment, Lake District, <5 km from Swindale) measurements of surface soil moisture, which also compared ungrazed semi-natural grasslands and permanent pasture, concluding that soil moisture between management type was significantly different in response to seasonal storm events and antecedent conditions (Wallace and Chappell, 2020). Aside from sampling methods used, one possible cause of the contrast between the findings of Wallace and Chappell (2020) and those of Bond et al. (2021) (Chapter Four) is the difference in management intensity for which moderate grazing, ploughing, re-seeding, artificial inputs and underdrainage were all present in the study by Wallace and Chappell (2020). In contrast, Swindale is currently managed using conservation-based methods which employ low-intensity grazing alongside exclusion zones.

In addition to the low-intensity management methods, it is also possible that the Rank Grassland, which was excluded from grazing 5-7 years prior to my research, had not yet sufficiently 'recovered' from any previous compaction influence to have significantly lower bulk density or higher  $K_s$ . There are few studies regarding the recovery of soils after a change in management, and existing estimates vary significantly between 5 and 62 years (Gifford and Hawkins, 1978, Marrs et al., 2020, Marrs et al., 2018, Holden et al., 2007).

Therefore, 7 years is regarded as a short timeframe within which soils might recover, even where above-ground vegetation has undergone significant change in roughness (see section 5.3). It is, therefore, possible that soil properties within the Rank Grassland in the coming years may yet be significantly different from soil properties in the Low-density Grazing habitat because of management influence.

### 5.2.2 Physical drivers of subsurface hydrology

Instead of management, soil depth and slope were considered to be the primary drivers of overland flow production, which began almost immediately after rainfall onset at the locations monitored (see Chapter Two). This is reflected in the horizons of the soils present, with Malvern 611a soils primarily present in the upper slopes, and Bangor 311e soils in the lower slopes. Malvern 611a soils are brown podzolic soils (WRB: Chromic Endoleptic Umbrisols), described as well-drained, very stony loamy soils and typically form on moderate to steep boulder slopes. They have a black, loamy peat surface horizon, underlain by a brown, slightly stony sandy silt loam horizon; beneath that, a yellowish-red, very stony sandy silt loam horizon followed by a brown, extremely stony sandy loam (Cranfield University, 2022). Although overland flow was frequently produced in the upper slopes, soil moisture was more transient than in the lower slopes, remaining saturated for shorter periods of time. This allowed soil horizons to become more developed with signs of nutrient leaching in the profile (Chapter Two).

Comparatively, Bangor 311e soils are humic ranker soils (WRB: Dystric Epileptic Histosols), described as very shallow, very acid, peaty-topped upland soils. They have a black, slightly stony semi-fibrous peat surface horizon, underlain by a black, extremely stony humose coarse sandy loam horizon which sits on rhyolite bedrock. In Chapter Two, soils at the bottom of the slope were found to have higher soil moisture and more frequently produce overland flow than those at high elevation. This is likely a reflection of drainage due to slope angle. Frequent waterlogging at both elevations explains the high SOM content, caused by limited decomposition induced by anaerobic conditions; however, in the lower slopes organic material comprises the whole profile which suggests prolonged waterlogging,

further supported by the longer duration periods of overland flow recorded in the lower slopes (Chapter Two).

Although soil horizons broadly reflected their slope position, soil properties within each grassland type were highly variable with no threshold at which overland flow occurred; additionally, soil depth to the underlying shale was found to vary between 10 cm and 30 cm (Chapter Two). It is likely that the high within-habitat heterogeneity for soil properties and moisture reflects the highly variable surface and subsurface microtopography within which patches of land are saturated, 'filled' and 'spilled', causing rapid runoff pathways downslope (McDonnell et al., 2021). Soil depth variability may also explain why no threshold of percentage soil moisture to overland flow production was found (Chapter Two). If the subsurface topography varies significantly, the storage capacity per 'patch' may vary enough to prevent saturation in certain locations. Alternatively, microtopography may route runoff into depressions and surface runoff channels which bypass some locations (Frei et al., 2010). Given the above, it is possible that the high heterogeneity caused by physical catchment characteristics masked those caused by management (see section 0).

Spatial location within the catchment was thought to be important in determining how land management influences flood peak size and timing. For Swindale and Calderdale, where both catchments were modelled from source to outlet with very few tributaries (Chapter Four), synchronisation was not likely to be a contributing factor towards flood peaks or timing as it is on larger scales (Nutt and Perfect, 2011). However, the position of management may have been the controlling factor given that Swindale had mostly riparian and near-stream NFM whereas Calderdale had primarily mid-slope based NFM. Without the ability to isolate sub-catchment sections, reasons why management effectiveness differed is conjecture only (see section 0). It is possible that where Calderdale's slopes were much steeper, interception and permeability outweighed roughness due to the overriding effects of gravity.



## 5.3 The influence of land management on surface hydrology

Once overland flow is produced, surface roughness is known to exert a strong control over overland flow velocity (Chapter Three; see references in section 0). Unlike for the subsurface hydrology, Swindale management was a primary control of hydrological function at the surface, significantly affecting velocity in response to seasonal management practices alongside natural vegetation growth and decay (Chapter Three). When scaled up to the catchment scale, changes in surface roughness had a large influence over modelled total and overland flow runoff peaks (Chapter Four). This suggests that for upland catchments with shallow soils which frequently produce overland flow, surface roughness is a vital control which can be managed through grazing, exclusion, and planting methods.

Conclusions drawn in Chapter Three may be especially transferable to other catchments as, when compared to the 2007 CEH UK land cover map (Morton et al., 2011), all sampled Swindale grassland types occur within the three most populous land-use categories: Improved Grassland (UK cover 23.60 %, includes Good Grazing, Rough Grazing & Hay Meadows), Rough Grassland (UK cover 5.48 %, includes the Excluded habitat) and Acid Grassland (UK cover 6.94 %, includes Bracken).

Management is also an important modifier of vegetation heterogeneity (Adler et al., 2001); this influences the structure of the vegetation, altering the possible friction against overland flow. In Chapter Three, Rank Grassland, which had been excluded from grazing for six years prior to fieldwork, was significantly rougher than the adjacent low-density grazing, its previous land use designation. This gives some indication of the level of above-ground rate of change in roughness, lending weight to the use of grasslands as a quick-acting NFM method of 'slowing the flow', or as a short-term 'stop-gap' whilst woodland measures develop (see section 0, Revell et al. (2021)).

### 5.3.1 Vegetation structure

The most important component in controlling overland flow velocity was hypothesised to be the portion of vegetation 0-5 cm above the surface that comes into direct contact with surface runoff (Chapter Three). This theory is strongly supported by Monger et al. (2022a), Prosser et al. (1995) and (Chiew and Tan, 1992) who all studied grassland-based habitats.

However, the portion of vegetation closest to the ground is very difficult to measure and widely varies with vegetation structure. Additionally, the micro-topography of the ground surface influences preferential flow pathways in combination with the vegetation present (Dunne et al., 1991); microtopography influences vegetation growth and species diversity through its influence on nutrient cycling, soil temperature and flow pathways, and is affected in turn by vegetation rooting and the influence of deposition, compaction and agricultural practices such as ploughing (Sarkar et al., 2019, Gumbricht et al., 2005, Courtwright and Findlay, 2011, Sterling et al., 1984, Bogner et al., 2013). Because of difficulties in accurate measurement of near-ground surface roughness (although advances are being made using high-resolution terrestrial laser scanning (Graham et al., 2020, Stovall et al., 2019, Vasilopoulos, 2017)), descriptions of vegetation species, ground surface, and associated flow velocities have thus far been used to relate roughness and velocity. Although there are many field and laboratory studies which measure the influence of surface roughness on flow velocities (Roels, 1984, Chiew and Tan, 1992, Gilley and Finkner, 1991, Abrahams et al., 1986, Wainwright et al., 2000, Prosser et al., 1995, Li and Pan, 2018, Pan et al., 2016, Pan et al., 2006, Shang et al., 2020, Takken and Govers, 2000), there are very few which are based in temperate climate vegetation. Therefore, the values collected in this thesis are a valuable addition to our understanding of temperate hydrology, and especially for flood modelling (see section 0; Chapter Four). Figure 5.1 collates the vegetation types currently measured for upland temperate climates (Chapter Three, Holden et al. (2008), Monger et al. (2022a)), placing them in order of annual mean roughness and grouping them by the near-ground vegetation characteristics hypothesised to be the most influential to runoff velocity.

The roughest habitats, Peat moss (*Sphagnum*), Peat grassland and moss mix (*Eriophorum* and *Sphagnum*) and Low-density grazing (underlain by *Rhytidiadelphus squarrosus*) all have a base mossy layer. Moss is well-known for its criss-crossed carpet-like structure which has the ability to store water, where *Sphagnum* can hold up to 20 times its dry weight (Clymo, 1970, Lees et al., 2020). In research investigating peatland re-vegetation for NFM, Shuttleworth et al. (2019) cite moss cover as a primary influence on the attenuated hydrograph.

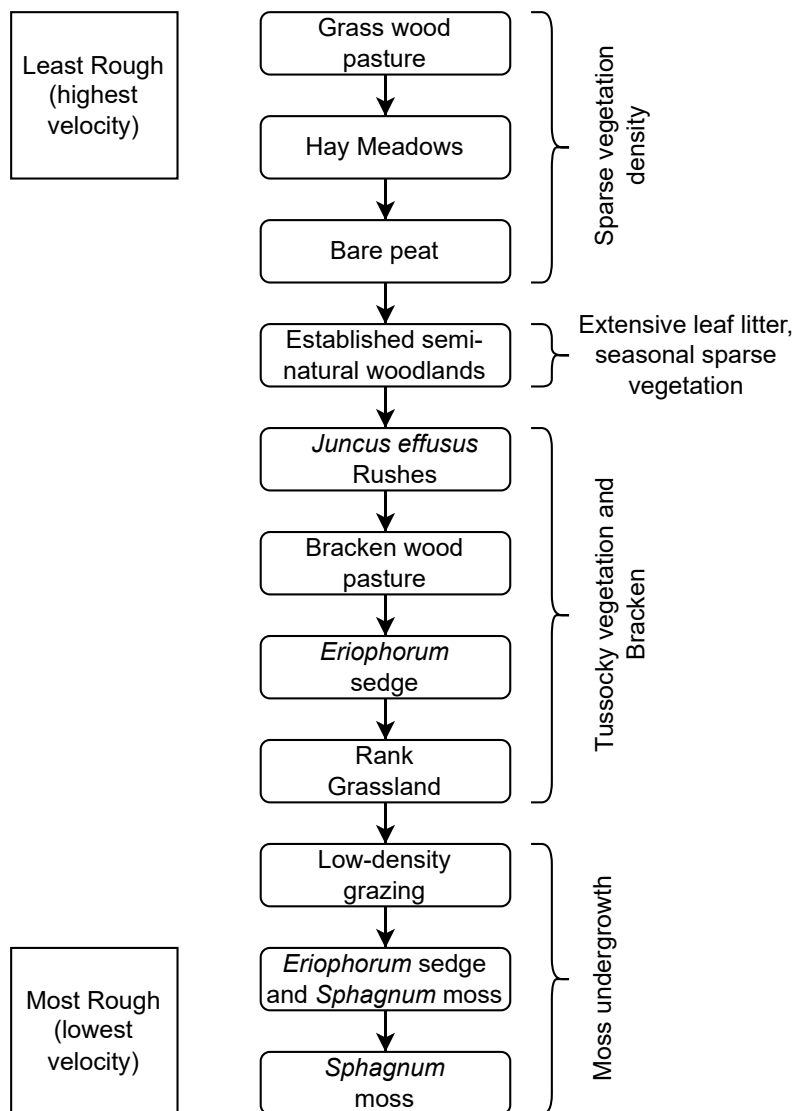

Figure 5.1: Vegetation roughness based on (measured and assumed) annual average overland flow velocity measurements by Bond et al. (2020), Holden et al. (2008) and Monger et al. (2022). Habitats within Monger et al. (2022): Grass wood pasture, established semi-natural woodlands and Bracken wood pasture. Habitats within Holden et al. (2008): *Eriophorum* sedge, *Eriophorum* sedge and sphagnum moss, and *Sphagnum* moss. Diagram based on table within Monger et al. (2022). Measurements by Monger et al. (2022) and Holden et al. (2008) were not seasonally collected, therefore velocities were assumed to be annual average.

Excluding Bracken, the next roughest habitats - Rushes, Peat grassland (*Eriophorum*) and Rank Grassland - are 'tussocky' in nature, with densely packed, immovable stems that act like a barrier to flow (Prosser et al., 1995). In Swindale, overland flow was observed either meandering around tussock bases or building in depth behind them until a height was reached at which the water could trickle through the stems (Chapter Three). However, it might be possible that diversion of overland flow caused by tussocky vegetation leads to

concentration of water elsewhere if flow is rerouted into rapid runoff pathways such as those caused by grazing livestock compaction (Meyles et al., 2006).

Overland flow velocity measurements for Bracken wood pasture were made in October when Bracken was decaying (Monger et al., 2022a). Because of this, many of the Bracken stems were folded over, providing ground-level, dense vegetation which was fixed in place. It is possible that Bracken would vary significantly in roughness seasonally as its foliage cover varies between almost bare soil and tall individual stems.

The established semi-natural woodland had extensive leaf litter, seasonally present vegetated undergrowth, and decaying wood on the woodland floor. Since species compete for sunlight, all vegetative undergrowth in the woodland was taller than the overland flow depth for the majority of the year, and therefore made little difference to runoff velocity. Similar observations were made by Wainwright et al. (2000) who noted that vegetation and litter were important controls on grassland, but stone cover was the dominant control in shrublands due to the shrub height above the surface flow. Leaf litter is likely to have contributed to roughness in the woodland, however the surfaces of leaves are relatively smooth and easily moved when flow velocity is strong enough; this may allow rivulets to form along paths of least resistance, creating some fast flow. Finally, the least rough habitats – bare peat, Hay meadows and grass wood pasture – were all subject to sparse vegetation density at ground level.

Since Figure 5.1 shows the only upland temperate habitats where hillslope hydraulic roughness has so far been measured and, noting that studies of each habitat were restricted to individual sites, it cannot be concluded that the 'order of roughness' given is definitive. The structure of understory vegetation varies widely with spatial location, species present and in response to different managements applied (Hamberg et al., 2009, Tasker and Bradstock, 2006, Messier et al., 2009). However, the inferences made regarding vegetation structure and its association with downstream velocity can still be directly applied to land-use management, targeting select structural features for planting or development, especially in locations which are vulnerable to overland flow. Ultimately, the contribution of woodlands, hedgerows, grasslands, or other land uses to runoff in a mosaiced landscape

depends on multiple factors that influence hydrology, differing between catchments (see section 5.5).

## 5.4 The influence of seasonality

### 5.4.1 Surface roughness

This research was the first to quantify seasonal differences in overland flow velocity as the result of vegetative surface roughness, accounting for both natural growth and decay in addition to annual management practices. Chapter Three showed that surface roughness changed with season in all habitats studied and with management where it was applied. Where season alone influenced roughness, a 'U-shaped' pattern was produced in the mean velocity response curve over the year reflecting natural vegetation growth and decay. As vegetation grew, roughness increased and therefore velocity decreased. Where management was applied, change in roughness was influenced by management in addition to growth and decay; this resulted in abrupt velocity changes which were mediated depending on growth or decay. In Swindale, two management practices were investigated, grazing and vegetation cutting, both of which were seasonally applied; for example, Hay Meadow cutting always occurs at the first opportunity after 25<sup>th</sup> July. As a result, seasonality and management were inextricably linked.

In Swindale, winter roughness was found to be equally effective in the Rank Grassland and Low-density Grazing habitats. In summer, Rushes and Rank Grassland were the most effective. Each habitat, including Hay Meadows for which roughness was always less than the other land uses, likely 'slowed the flow' for different reasons based on the portion of vegetation in contact with surface runoff, as determined by the depth of flow (see section 0). At the lowest flow rate, 1.2 L/min, maximum overland flow depth was 0.018 m and recorded flow velocity varied by only 0.0082 m s<sup>-1</sup>; for the highest applied flow rate, 12 L/min, maximum depth was 0.058 m and mean flow velocity varied by 0.45 m s<sup>-1</sup>. The increased range in velocity was concluded to be the result of greater variation in vegetation structure, density and flow pathways created by the taller portion of the vegetation present. This is also the portion most vulnerable to changes in seasonality and management (Clarke et al., 2008, Prosser et al., 1995, Adler et al., 2001).

## 5.4.2 Climate and antecedent conditions

Seasonality is not only important from a roughness perspective; storm events and antecedent conditions also vary seasonally (Ledingham et al., 2019, Wallace and Chappell, 2020, Deguchi et al., 2006, Hirmas et al., 2018) and therefore will influence the extent of control vegetation has over 'slowing the flow'. UK storm events are typically low-intensity frontal rainfall events which last several hours, inducing low-intensity saturation-excess overland flow (Boardman, 2001). In comparison, high-intensity events, driven by frontal or convective storms which produce rainfall  $>12 \text{ mm hr}^{-1}$  (compared to maximum  $18 \text{ mm hr}^{-1}$  over 100m ( $12 \text{ L min}^{-1}$  flow rate in flume) measured in Chapter Three), are comparatively rare, occurring  $\sim 10$  times per year for a few minutes duration (Holden and Burt, 2002). However, the frequency of intensive storm events is projected to increase with climate change (Lowe et al., 2018). Compared to the period between 1981 and 2000, by 2070 UK summers are likely to be up to 47% drier, with increased late-summer and autumn convective storm events, and winters are likely to be up to 35% wetter with increased storm severity (Met Office, 2021). Therefore, the dominance of different hydrological pathways, and the role of vegetation in 'slowing the flow', will also likely change seasonally. It is probable, however, that grassland roughness will still be able to mitigate against increasingly large storm events with results from Chapter Four showing roughness to be an effective tool against rainfall intensity of up to  $35.7 \text{ mm hr}^{-1}$ . This is further validated by Shuttleworth et al. (2019), who found that increasing roughness through re-vegetation of peatland with grasses and moss reduced peak storm flows by 27%, even under high magnitude events.

Depending on antecedent conditions, high-intensity storms may induce infiltration-excess overland flow (especially where the soil surface has dried), or quickly saturate soil storage inducing saturation-excess flow; in either case, the depth of overland flow induced is greater than for commonly occurring events, altering the extent of runoff control by vegetative roughness. As the depth of overland flow increases, taller vegetation comes into play (see section 0, Wainwright et al. (2000)). On a seasonal basis, roughness and storm events are frequently opposed; when vegetation is least rough, the most flood-inducing storms typically occur.

Vegetation management may not only be effective for increasing surface roughness, but also for mitigating against negative subsurface hydrological changes. For example, tall vegetation and woodland may be used to shade ground-based vegetation, reducing soil evaporation to mitigate against drought, soil hydrophobia and vegetation dieback (Ghazavi et al., 2008). This may be especially important for future climate scenarios which predict hot, dry summers followed by heavy convective rainfall events in the late summer and autumn. Vegetation management also influences macropore formation along root channels, enabling water infiltration to deeper soil horizons. Depending on catchment characteristics, macropores have been shown to influence preferential flow pathways downslope by increasing pore connectivity, affecting the rate of soil saturation, and increasing throughflow (although in some instances this can increase runoff rates) (Chappell, 2010, Beven and Germann, 2013). In addition, vegetation management has been shown to enhance recovery of soils following compaction (Colombi et al., 2017). By protecting vegetation, surface roughness and soil permeability can be seasonally maintained for NFM and drought mitigation.

## 5.5 Key implications for NFM

### 5.5.1 Grassland versus woodland

Although Monger et al. (2022a) found woodland to have lower surface roughness than some grassland and pasture habitats (section 0), woodlands consistently have higher  $K_s$  (Archer et al., 2013, Archer et al., 2012). Woodlands have also been reported to produce less surface runoff (Chandler et al., 2018) and produce a more 'muted' response to storm events than grasslands (Monger et al., 2022b). The same has been shown in hedgerows, which produced less overland flow incidence and volume than adjacent agriculturally improved pasture (Wallace et al., 2021). Therefore, if woodlands and hedgerows reduce the volume of overland flow, it may matter less that they are not as rough.

The management scenarios modelled changes in roughness alongside changes in permeability and interception (Chapter Four). Taking account of the natural succession scenarios (2\_2, rank grassland dominates, to 2\_5, 80% woodland), in Swindale, flood peak increased with decreasing roughness, despite higher permeability and interception. This

suggests that roughness outweighed water storage in importance for controlling runoff. In Calderdale, 2\_5 was the most effective scenario followed by 2\_2, suggesting that permeability and interception had greater control. The difference between catchments highlights the importance of choosing the right NFM for the right catchment where differing topography and position of management influences runoff pathways and any synchronisation involved (see section 0). Additionally, if woodland is more beneficial in the long-term, grassland may be considered as a deliberate stopgap which aids NFM through its increased roughness whilst the woodlands establish (see section 5.3). Consideration should be given to all habitat types and mosaics of habitats that may have the desired permeability or structural characteristics, also accounting for their management and influence on catchment hydrology as a function of their spatial position. Possible habitats include heaths, such as heather and bilberry with a mossy understorey, open woodlands with dense understoreys, or mosaics of trees and scrub with rank grasslands.

### 5.5.2 Seasonal implications

In Swindale, the propensity for overland flow generation is controlled by primarily by physical catchment characteristics (Chapter Two), antecedent conditions and storm magnitude (see section 0). Once overland flow is generated, vegetative effectiveness for 'slowing the flow' is a product of both management and season (Chapter Three) where winter roughness was equally effective in the Rank Grassland and Low-density Grazing habitats, and in summer, Rushes and Rank Grassland were the most effective. Translated to the catchment scale, Chapter Four showed that seasonal changes in vegetative roughness could alter flood peaks by +2.2 % in winter and -5.5 % in summer. When planning NFM initiatives, the combined influence of subsurface and surface hydrology must be accounted for, with consideration for the time of year flood mitigation is most needed (see section 0).

### 5.5.3 The effectiveness of OM grasslands at the catchment scale

By using empirical data as model inputs, resulting hydrographs are a more accurate representation of local hydrological processes (Beven et al., 2020). Chapter Four showed that comparatively small conversions in land use can significantly change peak runoff. For example, excluding the historical high intensity grazing scenario, grasslands accounted for



9.2% of Swindale and 27.5 % of Calderdale but overland flow peak was reduced by up to 24.2% in Swindale and 41.0% in Calderdale. This is significant as few empirically based studies exist which show significant influence of land management change on flood peaks (Burgess-Gamble et al., 2017, Kay et al., 2019).

Although Chapter Three suggested significant runoff attenuation over a theoretical 100 m hillslope, this was not reflected at the catchment scale (Chapter Four) in peak timings. However, earlier modelling of runoff attenuation features in Swindale by Hankin et al. (2019), and of multiple-NFM measures in Calderdale by Willis and Klaar (2021), also produced minimal difference in peak timing. Despite this, all three studies show effectiveness for the NFM applied (Hankin maximum peak reduction 6%; Willis and Klaar maximum peak reduction 6.1 %; Bond maximum peak reduction 42.0 %), where the variation in percentage likely reflects differences in the size, position, and type of NFM applied, as well as the model use, scale applied, and parameter sources.

#### 5.5.4 Ecosystem services

Grasslands have many different functions and sometimes other ecosystem services outweigh the need for NFM. Hay meadows have significantly declined in Britain in the past 100 years, possibly by 97 % (Riley, 2005), and therefore the remaining spaces are crucial to restoring native species which are now at risk. Although situated in the riparian zone in Swindale, the zone most influential to flood peaks, replacing the hay meadow with rank grassland for the sake of flood management would likely have negative biodiversity outcomes.

As noted by Richert et al. (2011), the objective of land-use change is essential in determining which measures are selected; unfortunately, conservation, flood management and farming are often seen as opposing (Bark et al., 2021), whereas they can be used in combination successfully. For example, in Chapter Four, conservation management, for which low-density grazing and hay meadow land uses were maintained, reduced overland flow peaks by up to 28.8 % in Swindale and 42 % in Calderdale when compared to the high intensity grazing scenario. Conservation-based management such as this is especially relevant with

the introduction of the England Woodland Creation Offer (EWCO; Defra (2021a)) and the UK-wide Future Farming Schemes (FFS; (Defra, 2022a, Defra, 2022b, Defra, 2021b)) both of which work towards the provision of public goods, including local nature recovery, water quality, and flood and drought mitigation.

## 5.6 Limitations and recommendations for future research

### 5.6.1 Fieldwork

Fieldwork was conducted in one upland catchment which may have given a narrow viewpoint on OM soils. Chapter Two found shallow soil depth to be the primary driver of runoff creation; however, for catchments with deeper soils, permeability and soil storage may be more important influences over runoff.

In Swindale, deeper soil horizons could not be assessed due to shallow depth and underlying shale and bedrock. Although depth was assumed to be the primary cause of quick saturation, it is possible, although unlikely from visual assessment using soil pits, that underlying horizons were less permeable and therefore a second cause of frequent overland flow production. Lateral permeability could also not be assessed due to the soil depth and shale presence; in planning fieldwork it was hoped measurements of lateral permeability could be used in discussion of throughflow connectivity downslope.

It is likely Swindale was also limiting as a catchment already under conservation management. Grazing practices were all 'low-density' and therefore soil properties and vegetative roughness reflected that. Consequently, it is difficult to apply findings in Swindale to catchments with 'normal' farming management (such as that assumed in Calderdale) and less relevant to those with 'intensive' management. Heterogeneity within grasslands also limits applicability to other catchments, even those with similar species and management.

## 5.6.2 Modelling

### Roughness coefficients

Traditionally, there are three equations used to calculate roughness: Manning's coefficient ( $n$ ), Chézy coefficient ( $C$ ) and Darcy-Weisbach roughness ( $f$ ).  $n$  and  $C$  were both originally used to describe wall roughness, where  $n$  was developed for turbulent flow and  $C$  for flows with a low Reynolds number (Augustijn et al., 2008).  $f$  was designed for pipe flows can be used with both laminar and turbulent flows and, alongside  $n$ , is the most commonly used roughness coefficient in hydrological modelling (Smith et al., 2007). Both  $f$  and  $n$  coefficients assume that measured roughness is equivalent to fully submerged grains on a riverbed and often strongly correlate to flow depth (Barros and Colello, 2001). All three roughness coefficients do not account for vegetation

In Chapter Three,  $f$  was shown to be related to the ratio of flow depth ( $d$ ) to equivalent grain roughness ( $k$ ), where an increase in  $d/k$  should produce a decrease in  $f$  if  $k$  remains constant. A constant grain roughness model was produced for regularly spaced  $f$  values, calculating  $d$  and using that value to calculate velocity and discharge. In plotting modelled discharge against velocity for turbulent and laminar flow, and adding Swindale data alongside, Swindale data was shown to be of laminar flow with velocity ten times less than the modelled data. As such,  $f$  greatly over-estimated measured flow velocity. Relative roughness ( $k^*$ ) was then calculated following the constant grain roughness model, to investigate the relationship between  $k^*$  and seasonality; velocity and applied flow rates from fieldwork were used.  $k^*$  was found to change seasonally in response to changes in growth and management. In addition to  $f$  over-estimating velocity, changing  $k^*$  values question the appropriateness of  $f$  for modelling, because  $f$  assumes  $k$  should remain constant with increasing depth.

Further to examining the appropriateness of  $f$ ,  $n$  has been regularly questioned as an appropriate roughness measure. Engman (1989) stated that using Manning's  $n$  for calculating shallow overland flow velocities was a 'severe misuse' of the equation due to simplistic calculations which are based on open channel hydraulics. Chiew and Tan (1992) agreed, finding that the exponent for overland flow depth over *Axonopus Compressus* turf was 0.6, the same as is usually reserved for open channel high flow depths. Recent research

has also found flaws: Zhang et al. (2021) found that, for sparse vegetation,  $n$  is correlated to different hydraulic parameters, therefore the same vegetation coverage can have different effects on overland flow resistance. Monger et al. (2022a) found  $n$  to be ‘far from constant’ in shallow overland flows and, when converting velocities to  $n$ , calculated values to be an order of magnitude higher than those reported by Chow (1959).

Despite problems,  $f$  is currently the basis of SD-TOPMODEL’s calculations for roughness, even with relative parameter input values (Gao et al., 2015), and  $n$  is the basis, or recommended roughness, for a number of models including Dynamic TOPMODEL (Metcalf et al., 2015), HEC-RAS (Brunner and CEIWR-HEC, 2020) and MIKE-SHE (DHI, 2022). Although their use has been condemned, many catchment models (Burgess-Gamble et al., 2017, Phillips and Tadayon, 2006, Manandhar, 2010, Nagy et al., 2018, Kiss et al., 2019) still use the simplistic values calculated by Chow (1959) to inform hillslope roughness. So engrained is the use of  $f$  and  $n$  in hydrology, that a seismic shift in thought may be required to truly understand the influence of roughness in hillslope runoff. A review of roughness differentials by Smith et al. (2007) recognises this, acknowledging that  $C$ ,  $n$  and  $f$  are currently the most widely used roughness equations in hydrological modelling, and that greater understanding of overland flow processes must be developed before alternatives can be widely applied. Although also subject to problems, this thesis recommends velocity as an alternative, which is already the basis of many field and laboratory studies (see Chapter Three; section 0).

### Parameter inputs

Parameter inputs to TOPMODEL are relative, therefore it does not necessarily matter what the ‘units’ are (e.g., velocity,  $n$ ,  $f$ ) as long as inputs have the same source units, or can be converted to the same units, and have good scientific basis. However, there are some problems regarding this.

Firstly, if parameters are used from different sources, an assumption is made that the data used were obtained using similar methods and with equal scientific rigour. Only empirically collected data were used within this thesis, directly measured within Swindale, or else taken from modern research in similar environments. However, fieldwork methods may induce

error through inappropriate equipment used or poor technique (Chappell and Lancaster, 2007). Often, models use laboratory-calculated data, or 'traditional' sources, such as the simplistically calculated Manning's  $n$  values by Chow (1959). These values especially have been challenged through roughness measurements in Chapter Three and by Monger et al. (2022a); if commonly used parameter values falsely represent temperate environments, how many models perpetuate, and indeed encourage, false catchment management ideals for flood mitigation?

Secondly, if data were obtained from different catchments to the one modelled, there is no guarantee that the data applied are appropriate to the environment they represent. For example, in Chapter Four, woodland properties data were applied from the neighbouring catchment to Swindale, the Naddle Valley, and from fieldwork in Calderdale. Even with data from relatively close locations at similar elevation, there is no guarantee that woodland in Swindale would have the same properties. Instead, an assumption is made that the parameters are appropriate. Ideally, parameters would come from the catchment modelled, or else the same catchment as each other (and with similar management to the receiving catchment) so at least relative differences between habitats are maintained.

#### Assessing the contribution of distributed land management to flood peaks

SD-TOPMODEL is designed to be fully distributed, allowing different land uses to be easily compared. However, there is no current method for isolating the influence of one sub-catchment alone without developing a second model for that catchment. Although parameters can be made 'neutral' by setting values to 1 (where values in SD-TOPMODEL are relative and therefore 1 is equivalent to the baseline land use), the lack of sub-catchment division makes it difficult to assess whether certain sections of the catchment contribute to flood management more than others.

Heterogeneity is limited in hydrological models, even those that are fully-distributed such as SD-TOPMODEL. For modelling, parameter application is only possible at the scale chosen, limited by empirical data availability and model processing power. Additionally, there was an assumption that scaling field-based measurements up to the catchment scale was appropriate, despite little empirical evidence of NFM effectiveness at the catchment scale

(Dadson et al., 2017). In converting field-values (Chapters Two and Three) to  $K$  and  $Kv$  parameters, data were averaged per habitat, removing an element of heterogeneity even prior to modelling process.

### Model uncertainty and assumptions

Hydrological models seek to represent the landscape in simplified form, therefore all models are subject to uncertainty and assumptions (Beven, 2012). The catchments modelled were chosen for their similar features (see section 4.3.1). Use of ReFH ensured the two catchments modelled were comparable on the basis of storm magnitude and duration; and validation using observed data justified ReFH as being representative of real storms within each catchment. However, the two catchments have very different topographies. Calderdale was chosen alongside Swindale so that scenarios could test the effectiveness of NFM under different catchment characteristics; this is important in justifying applicability of NFM initiatives.

Although catchments were comparable, due to available data and resolution, model uncertainty for Calderdale was greater than that of Swindale. Empirical field-based data was more widely available in Swindale than Calderdale. Where data directly from each catchment was not available, an assumption was made that data from another catchment would appropriately represent the land covers modelled. With greater data availability, land cover could have been more accurately represented in both catchments, especially Calderdale.

The cell resolution was also different between catchments. When modelling for Swindale a 5 m DEM was used, therefore differences in soil properties, vegetative roughness, catchment characteristics etc could theoretically be represented every 5 m. In Calderdale, the scale was coarser, with a 20 m DEM. With different catchment scales, the differentiation between land management was more detailed in Swindale, allowing rushes to be modelled within the low-density grazing. In Calderdale, the scale was prohibitive in places, especially when modelling narrow or small features such as roads. Although a more detailed DEM was available for Calderdale, processing time was limited to 48 hours which was unachievable with a  $<20$  m DEM and  $>20$  km<sup>2</sup> catchment.

Fully distributed models are often associated with a large degree of uncertainty caused by the high number of parameters involved; this can lead to difficulty with calibration and associated equifinality. Equifinality, the concept that multiple parameter sets can lead to the same model outcome, is mitigated in SD-TOPMODEL due to the limited number of primary calibration parameters (Her and Chaubey, 2015). Although parameter uncertainty was reduced due to the limited SD-TOPMODEL variables and empirical data sources, a comprehensive sensitivity analysis, such as GLUE or Bayesian Model Averaging, was not possible due to the large computation requirements required. Therefore, the appropriateness of parameters used, although mitigated as much as possible, was a critical assumption of the modelling.

Finally, within SD-TOPMODEL itself, three critical assumptions are made (Gao et al., 2015):

- 1) *The soil hydraulic conductivity decreases exponentially with increasing water deficit below saturation*
- 2) *Rainfall and runoff are spatially uniform in a cell*
- 3) *The Manning's equation is used as an expression of land surface resistance to overland flow*

These assumptions cannot currently be changed using model inputs. However, all were considered reasonable assumptions against the suitability of SD-TOPMODEL for assessing the influence of season and management on modelled flood risk (see section 4.3.2).

### 5.6.3 Future research recommendations

It is recommended that future research be undertaken to:

- Measure soil properties and their response to (physical and modelled) storm events over a greater range of OM soil types, catchment properties and managements, especially those with more heavily managed systems.
- Understand more about the controls (possibly related to microtopography (Frei et al., 2010) and 'fill and spill' mechanisms (McDonnell et al., 2021)) governing surface and subsurface flow interaction in OM soils, including for lateral and vertical flow directions, and how they apply in different catchment settings.

- Monitor how OM soils and grassland vegetation changes over time in response to different managements applied, assessing the rate of any 'recovery' processes.
- Develop new techniques or adapt currently used techniques (possibly structure-from-motion (Wolstenholme et al., 2020, Li et al., 2019) or terrestrial laser scanning (Smith et al., 2011, Vasilopoulos, 2017)), which enable measurement of vegetative roughness in the first 5 cm above soil and investigate whether there is a correlation between this 'active' portion of the vegetation and overland flow velocity.
- Define seasonal roughness and associated overland flow velocity for a larger range of temperate vegetation types.
- Empirically monitor the effectiveness of land-use change for NFM at the catchment scale over time.

## 5.7 Final conclusions

This thesis has shown that OM soil grasslands and their management play a vital role in generating and controlling runoff in upland catchments. Subsurface hydrology was found to be primarily dependent on physical catchment characteristics, especially soil depth, for which highly permeable soils (averaging  $2.4 \text{ m day}^{-1}$ ) saturated frequently, producing overland flow up to 60% of the time. Surface hydrology was largely controlled by vegetation roughness which strongly responded to season and management influences. Winter overland flow velocities were significantly higher than in summer, further modified by grazing and cutting managements. When modelling whole catchment response to large storm events, seasonality was shown to alter flood peaks by between -5.5% to 2.2%. Management was also an important factor, with conservation management reducing flood peaks by up to 42% in comparison to recent land use. In summary, the influence of OM grasslands to runoff was recorded at both the hillslope and catchment scale, showing that upland grassland management is a viable and effective NFM option, especially as part of a mosaiced landscape for which multiple ecosystem services are required.



## 5.8 References

- Abrahams, A., Parsons, A., & Luk, S.-H. (1986). Resistance to overland flow on desert hillslopes. *Journal of Hydrology*, 88(3-4), 343-363.
- Adler, P., Raff, D., & Lauenroth, W. (2001). The effect of grazing on the spatial heterogeneity of vegetation. *Oecologia*, 128(4), 465-479.
- Archer, N., Bonell, M., Coles, N., MacDonald, A., Auton, C., & Stevenson, R. (2013). Soil characteristics and landcover relationships on soil hydraulic conductivity at a hillslope scale: A view towards local flood management. *Journal of Hydrology*, 497, 208-222.
- Archer, N., Bonell, M., Coles, N., MacDonald, A., Stevenson, R., & Hallett, P. (2012). *The relationship of forest and improved grassland to soil water storage and its implication on Natural Flood Management in the Scottish Borders*. Paper presented at the BHS Eleventh National Symposium, Hydrology for a changing world, Dundee, Scotland.
- Augustijn, D. C., Huthoff, F., & Van Velzen, E. (2008). *Comparison of vegetation roughness descriptions*. Paper presented at the River Flow 2008: 4th International Conference on Fluvial Hydraulics, Izmir, Turkey.
- Bark, R. H., Martin-Ortega, J., & Waylen, K. A. (2021). Stakeholders' views on natural flood management: Implications for the nature-based solutions paradigm shift? *Environmental Science & Policy*, 115, 91-98.
- Barros, A. P., & Colello, J. D. (2001). Surface roughness for shallow overland flow on crushed stone surfaces. *Journal of Hydraulic Engineering*, 127(1), 38-52.
- Beven, K., Asadullah, A., Bates, P., Blyth, E., Chappell, N., Child, S., . . . Fowler, H. J. (2020). Developing observational methods to drive future hydrological science: Can we make a start as a community? *Hydrological Processes*, 34(3), 868-873.
- Beven, K., & Germann, P. (2013). Macropores and water flow in soils revisited. *Water Resources Research*, 49(6), 3071-3092.
- Beven, K. (2012). *Rainfall-runoff modelling: the primer*. Second edition. Chichester, UK: John Wiley & Sons.
- Boardman, J. (2001). Storms, floods and soil erosion on the South Downs, East Sussex, autumn and winter 2000-01. *Geography*, 346-355.
- Bogner, C., Mirzaei, M., Ruy, S., & Huwe, B. (2013). Microtopography, water storage and flow patterns in a fine-textured soil under agricultural use. *Hydrological Processes*, 27(12), 1797-1806.
- Bond, S., Kirkby, M. J., & Holden, J. (2021). Upland grassland management influences organo-mineral soil properties and their hydrological function. *Ecohydrology*, e2336.
- Bond, S., Kirkby, M. J., Johnston, J., Crowle, A., & Holden, J. (2020). Seasonal vegetation and management influence overland flow velocity and roughness in upland grasslands. *Hydrological Processes*, 34(18), 3777-3791.
- Brunner, G. W., & CEIWR-HEC. (2020). *HEC-RAS River Analysis System User's Manual Version 6.0 Beta*. In CPD-68. CA, USA: US Army Corps of Engineers, Institute for Water Resources, Hydrologic Engineering Center (HEC).
- Burgess-Gamble, L., Ngai, R., Wilkinson, M., Nisbet, T., Pontee, N., Harvey, R., . . . Quinn, P. (2017). *Working with natural processes to reduce flood risk*. Bristol, UK: Environment Agency.

- Chandler, K., Stevens, C., Binley, A., & Keith, A. (2018). Influence of tree species and forest land use on soil hydraulic conductivity and implications for surface runoff generation. *Geoderma*, 310, 120-127.
- Chappell, N. A. (2010). Soil pipe distribution and hydrological functioning within the humid tropics: a synthesis. *Hydrological Processes*, 24(12), 1567-1581.
- Chappell, N. A., & Lancaster, J. W. (2007). Comparison of methodological uncertainties within permeability measurements. *Hydrological Processes*, 21(18), 2504-2514.
- Chiew, Y.-M., & Tan, S.-K. (1992). Frictional resistance of overland flow on tropical turfed slope. *Journal of Hydraulic Engineering*, 118(1), 92-97.
- Chow, V. T. (1959). Open-channel hydraulics. In *Open-channel hydraulics*. McGraw-Hill.
- Clarke, M., Creamer, R., Deeks, L., Gowing, D., Holman, I., Jones, R., . . . Ritz, K. (2008). *Scoping study to assess soil compaction affecting upland and lowland grassland in England and Wales*. Final project (BD2304) report to Defra. London: DEFRA.
- Clymo, R. (1970). The growth of Sphagnum: methods of measurement. *The Journal of Ecology*, 58(1), 13-49.
- Colombi, T., Braun, S., Keller, T., & Walter, A. (2017). Artificial macropores attract crop roots and enhance plant productivity on compacted soils. *Science of the Total Environment*, 574, 1283-1293.
- Courtwright, J., & Findlay, S. E. (2011). Effects of microtopography on hydrology, physicochemistry, and vegetation in a tidal swamp of the Hudson River. *Wetlands*, 31(2), 239-249.
- Cranfield University. (2022). The Soils Guide [online]. Available at: [www.landis.org.uk](http://www.landis.org.uk) [Accessed 27/01/2022]
- Dadson, S. J., Hall, J. W., Murgatroyd, A., Acreman, M., Bates, P., Beven, K., . . . Lane, S. N. (2017). A restatement of the natural science evidence concerning catchment-based 'natural' flood management in the UK. *Proceedings of the Royal Society A: Mathematical, Physical and Engineering Sciences*, 473(2199), 20160706.
- Defra. (2021a). England Woodland Creation Offer. Available at: <https://www.gov.uk/guidance/england-woodland-creation-offer> [Accessed 15/02/2022]
- Defra. (2021b). The new Sustainable Farming Incentive. *Future Farming*. Available at: <https://defrafarming.blog.gov.uk/2021/02/23/the-new-sustainable-farming-incentive/> [Accessed 15/02/2022]
- Defra. (2022a). Landscape Recovery: more information on how the scheme will work. *Policy Paper*. Available at: <https://www.gov.uk/government/publications/landscape-recovery-more-information-on-how-the-scheme-will-work/landscape-recovery-more-information-on-how-the-scheme-will-work> [Accessed 15/02/2022]
- Defra. (2022b). Local Nature Recovery: more information on how the scheme will work. *Policy Paper*. Available at: <https://www.gov.uk/government/publications/local-nature-recovery-more-information-on-how-the-scheme-will-work/local-nature-recovery-more-information-on-how-the-scheme-will-work> [Accessed 15/02/2022]
- Deguchi, A., Hattori, S., & Park, H.-T. (2006). The influence of seasonal changes in canopy structure on interception loss: application of the revised Gash model. *Journal of Hydrology*, 318(1-4), 80-102.
- DHI. (2022). MIKE SHE User Guide and Reference Manual. Available at: [https://manuals.mikepoweredbydhi.help/latest/MIKE\\_SHE.htm](https://manuals.mikepoweredbydhi.help/latest/MIKE_SHE.htm). [Accessed 16/02/2022].

- Dunne, T., Zhang, W., & Aubry, B. F. (1991). Effects of rainfall, vegetation, and microtopography on infiltration and runoff. *Water Resources Research*, 27(9), 2271-2285.
- Engman, E. (1989, May). *Applicability of Manning's n Values for Shallow Overland Flow*. Paper presented at the Proceedings of the International Conference for Centennial of Manning's Formula and Kuichling's Rational Formula, University of Virginia.
- Forbes, H., Ball, K., & McLay, F. (2015). *Natural Flood Management Handbook*. Stirling, UK: SEPA.
- Frei, S., Lischied, G., & Fleckenstein, J. (2010). Effects of micro-topography on surface–subsurface exchange and runoff generation in a virtual riparian wetland—A modeling study. *Advances in Water Resources*, 33(11), 1388-1401.
- Gao, J., Holden, J., & Kirkby, M. (2015). A distributed TOPMODEL for modelling impacts of land-cover change on river flow in upland peatland catchments. *Hydrological Processes*, 29(13), 2867-2879.
- Ghazavi, G., Thomas, Z., Hamon, Y., Marie, J.-C., Corson, M., & Mérot, P. (2008). Hedgerow impacts on soil-water transfer due to rainfall interception and root-water uptake. *Hydrological Processes*, 22(24), 4723-4735.
- Gifford, G. F., & Hawkins, R. H. (1978). Hydrologic impact of grazing on infiltration: a critical review. *Water Resources Research*, 14(2), 305-313.
- Gilley, J. E., & Finkner, S. C. (1991). Hydraulic roughness coefficients as affected by random roughness. *Biological Systems Engineering: Papers and Publications*, 122.
- Graham, J. D., Glenn, N. F., Spaete, L. P., & Hanson, P. J. (2020). Characterizing peatland microtopography using gradient and microform-based approaches. *Ecosystems*, 23(7), 1464-1480.
- Gumbrecht, T., McCarthy, T., & Bauer, P. (2005). The micro-topography of the wetlands of the Okavango Delta, Botswana. *Earth Surface Processes and Landforms*, 30(1), 27-39.
- Hamberg, L., Lehvävirta, S., & Kotze, D. J. (2009). Forest edge structure as a shaping factor of understorey vegetation in urban forests in Finland. *Forest Ecology and Management*, 257(2), 712-722.
- Hankin, B., Metcalfe, P., Beven, K., & Chappell, N. A. (2019). Integration of hillslope hydrology and 2D hydraulic modelling for natural flood management. *Hydrology Research*, 50(6), 1535-1548.
- Her, Y., & Chaubey, I. (2015). Impact of the numbers of observations and calibration parameters on equifinality, model performance, and output and parameter uncertainty. *Hydrological Processes*, 29(19), 4220-4237.
- Hirmas, D. R., Giménez, D., Nemes, A., Kerry, R., Brunzell, N. A., & Wilson, C. J. (2018). Climate-induced changes in continental-scale soil macroporosity may intensify water cycle. *Nature*, 561(7721), 100-103.
- Holden, J., & Burt, T. (2002). Infiltration, runoff and sediment production in blanket peat catchments: implications of field rainfall simulation experiments. *Hydrological Processes*, 16(13), 2537-2557.
- Holden, J., Chapman, P., Evans, M., Hubacek, K., Kay, P., & Warburton, J. (2007). *Vulnerability of organic soils in England and Wales*. Final technical report to DEFRA and Countryside Council for Wales. DEFRA Project SP0532. London: DEFRA.
- Holden, J., Kirkby, M. J., Lane, S. N., Milledge, D. G., Brookes, C. J., Holden, V., & McDonald, A. T. (2008). Overland flow velocity and roughness properties in peatlands. *Water Resources Research*, 44(6).

- Kay, A., Old, G., Bell, V., Davies, H., & Trill, E. (2019). An assessment of the potential for natural flood management to offset climate change impacts. *Environmental Research Letters*, *14*(4), 044017.
- Kiss, T., Nagy, J., Fehérvári, I., & Vaszkó, C. (2019). (Mis) management of floodplain vegetation: The effect of invasive species on vegetation roughness and flood levels. *Science of the Total Environment*, *686*, 931-945.
- Ledingham, J., Archer, D., Lewis, E., Fowler, H., & Kilsby, C. (2019). Contrasting seasonality of storm rainfall and flood runoff in the UK and some implications for rainfall-runoff methods of flood estimation. *Hydrology Research*, *50*(5), 1309-1323.
- Lees, K. J., Artz, R. R., Khomik, M., Clark, J. M., Ritson, J., Hancock, M. H., . . . Quaife, T. (2020). Using spectral indices to estimate water content and GPP in Sphagnum moss and other peatland vegetation. *IEEE Transactions on Geoscience and Remote Sensing*, *58*(7), 4547-4557.
- Li, C., Grayson, R., Smith, M., & Holden, J. (2019). Patterns and drivers of peat topographic changes determined from structure-from-motion photogrammetry at field plot and laboratory scales. *Earth Surface Processes and Landforms*, *44*(6), 1274-1294.
- Li, C., & Pan, C. (2018). The relative importance of different grass components in controlling runoff and erosion on a hillslope under simulated rainfall. *Journal of Hydrology*, *558*, 90-103.
- Lowe, J. A., Bernie, D., Bett, P., Bricheno, L., Brown, S., Calvert, D., . . . Fosser, G. (2018). *UKCP18 science overview report*. Met Office Hadley Centre: Exeter, UK.
- Manandhar, B. (2010). *Flood plain analysis and risk assessment of Lothar Khola*. (Master of Science), Institute of Forestry, Tribhuvan University, Phokara, Nepal.
- Marrs, R. H., Lee, H., Blackbird, S., Connor, L., Girdwood, S. E., O'Connor, M., . . . Chiverrell, R. C. (2020). Release from sheep-grazing appears to put some heart back into upland vegetation: A comparison of nutritional properties of plant species in long-term grazing experiments. *Annals of Applied Biology*, *177*(1), 152-162.
- Marrs, R. H., Sánchez, R., Connor, L., Blackbird, S., Rasal, J., & Rose, R. (2018). Effects of removing sheep grazing on soil chemistry, plant nutrition and forage digestibility: Lessons for rewilding the British uplands. *Annals of Applied Biology*, *173*(3), 294-301.
- Marshall, M., Ballard, C., Frogbrook, Z., Solloway, I., McIntyre, N., Reynolds, B., & Wheeler, H. (2014). The impact of rural land management changes on soil hydraulic properties and runoff processes: results from experimental plots in upland UK. *Hydrological Processes*, *28*(4), 2617-2629.
- Marshall, M. R., Francis, O. J., Frogbrook, Z. L., Jackson, B. M., McIntyre, N., Reynolds, B., . . . Chell, J. (2009). The impact of upland land management on flooding: results from an improved pasture hillslope. *Hydrological Processes*, *23*(3), 464-475.
- McDonnell, J. J., Spence, C., Karran, D. J., Ilja van Meerveld, H., & Harman, C. (2021). Fill-and-spill: A process description of runoff generation at the scale of the beholder. *Water Resources Research*, e2020WR027514.
- Messier, C., Posada, J., Aubin, I., & Beaudet, M. (2009). Functional Relationships Between Old-Growth Forest Canopies, Understorey Light and Vegetation Dynamics. In C. Wirth, G. Gleixner, & M. Heimann (Eds.), *Old-Growth Forests: Function, Fate and Value* (pp. 115-139). Berlin, Heidelberg: Springer Berlin Heidelberg.
- Met Office. (2021). *UK Climate Projections: Headline Findings (Version 3, July 2021)*. Exeter, UK: Met Office Hadley Centre.

- Metcalfe, P., Beven, K., & Freer, J. (2015). Dynamic TOPMODEL: A new implementation in R and its sensitivity to time and space steps. *Environmental Modelling & Software*, *72*, 155-172.
- Meyles, E., Williams, A., Ternan, J., Anderson, J., & Dowd, J. (2006). The influence of grazing on vegetation, soil properties and stream discharge in a small Dartmoor catchment, southwest England, UK. *Earth Surface Processes and Landforms*, *31*(5), 622-631.
- Monger, F., Bond, S., Spracklen, D., & Kirkby, M. (2022a). Overland flow velocity and soil properties in established semi-natural woodland and wood pasture in an upland catchment. *Hydrological Processes*, e14567.
- Monger, F., Spracklen, D., Kirkby, M., & Schofield, L. (2022b). The impact of semi-natural broadleaf woodland and pasture on soil properties and flood discharge. *Hydrological Processes*, e14453.
- Morton, D., Rowland, C., Wood, C., Meek, L., Marston, C., Smith, G., . . . Simpson, I. (2011). *Final report for LCM2007-the new UK land cover map. Countryside survey technical report no 11/07*. Lancaster, UK: NERC/Centre for Ecology & Hydrology (CEH Project Number: C03259).
- Nagy, J., Kiss, T., Fehérváry, I., & Vaszkó, C. (2018). Changes in Floodplain Vegetation Density and the Impact of Invasive on Flood Conveyance. *Journal of Environmental Geography*, *11*(3-4), 3-12.
- Nutt, N., & Perfect, C. (2011). *Allan Water Natural Flood Management Techniques and Scoping Study*. Stirling: SEPA
- Pan, C., Ma, L., Wainwright, J., & Shangguan, Z. (2016). Overland flow resistances on varying slope gradients and partitioning on grassed slopes under simulated rainfall. *Water Resources Research*, *52*(4), 2490-2512.
- Pan, C., Shangguan, Z., & Lei, T. (2006). Influences of grass and moss on runoff and sediment yield on sloped loess surfaces under simulated rainfall. *Hydrological Processes*, *20*(18), 3815-3824.
- Phillips, J. V., & Tadayon, S. (2006). *Selection of Manning's roughness coefficient for natural and constructed vegetated and non-vegetated channels, and vegetation maintenance plan guidelines for vegetated channels in Central Arizona*. Washington DC, USA: US Department of the Interior & US Geological Survey
- Prosser, I. P., Dietrich, W. E., & Stevenson, J. (1995). Flow resistance and sediment transport by concentrated overland flow in a grassland valley. *Geomorphology*, *13*(1-4), 71-86.
- Revell, N., Lashford, C., Blackett, M., & Rubinato, M. (2021). Modelling the Hydrological Effects of Woodland Planting on Infiltration and Peak Discharge Using HEC-HMS. *Water*, *13*(21), 3039.
- Richert, E., Bianchin, S., Heilmeyer, H., Merta, M., & Seidler, C. (2011). A method for linking results from an evaluation of land use scenarios from the viewpoint of flood prevention and nature conservation. *Landscape and Urban Planning*, *103*(2), 118-128.
- Riley, M. (2005). Silent meadows: the uncertain decline and conservation of hay meadows in the British landscape. *Landscape Research*, *30*(4), 437-458.
- Roels, J. (1984). Flow resistance in concentrated overland flow on rough slope surfaces. *Earth Surface Processes and Landforms*, *9*(6), 541-551.
- Sarkar, P., Das, T., & Adhikari, D. (2019). Variation in species assemblages due to micro-topography and flow regime govern vegetation carbon stock in seasonal floodplain wetlands. *Ecological Processes*, *8*(1), 1-15.

- Shang, H., Zhang, K., Wang, Z., Yang, J., He, M., Pan, X., & Fang, C. (2020). Effect of varying wheatgrass density on resistance to overland flow. *Journal of Hydrology*, *591*, 125594.
- Shuttleworth, E. L., Evans, M. G., Pilkington, M., Spencer, T., Walker, J., Milledge, D., & Allott, T. E. (2019). Restoration of blanket peat moorland delays stormflow from hillslopes and reduces peak discharge. *Journal of Hydrology X*, *2*, 100006.
- Smith, M. W., Cox, N. J., & Bracken, L. J. (2007). Applying flow resistance equations to overland flows. *Progress in Physical Geography*, *31*(4), 363-387.
- Smith, M. W., Cox, N. J., & Bracken, L. J. (2011). Terrestrial laser scanning soil surfaces: a field methodology to examine soil surface roughness and overland flow hydraulics. *Hydrological Processes*, *25*(6), 842-860.
- Sterling, A., Peco, B., Casado, M., Galiano, E., & Pineda, F. (1984). Influence of microtopography on floristic variation in the ecological succession in grassland. *Oikos*, *42*(3), 334-342.
- Stovall, A. E., Diamond, J. S., Slesak, R. A., McLaughlin, D. L., & Shugart, H. (2019). Quantifying wetland microtopography with terrestrial laser scanning. *Remote Sensing of Environment*, *232*, 111271.
- Takken, I., & Govers, G. (2000). Hydraulics of interrill overland flow on rough, bare soil surfaces. *Earth Surface Processes and Landforms*, *25*(13), 1387-1402.
- Tasker, E. M., & Bradstock, R. A. (2006). Influence of cattle grazing practices on forest understorey structure in north-eastern New South Wales. *Austral Ecology*, *31*(4), 490-502.
- Vasilopoulos, G. (2017). *Characterising the structure and fluvial drag of emergent vegetation*. (PhD Thesis), University of Southampton.
- Wainwright, J., Parsons, A. J., & Abrahams, A. D. (2000). Plot-scale studies of vegetation, overland flow and erosion interactions: Case studies from Arizona and New Mexico. *Hydrological Processes*, *14*(16-17), 2921-2943.
- Wallace, E. E., & Chappell, N. A. (2020). A statistical comparison of spatio-temporal surface moisture patterns beneath a semi-natural grassland and permanent pasture: From drought to saturation. *Hydrological Processes*, *34*(13), 3000-3020.
- Wallace, E. E., McShane, G., Tych, W., Kretschmar, A., McCann, T., & Chappell, N. A. (2021). The effect of hedgerow wild-margins on topsoil hydraulic properties, and overland-flow incidence, magnitude and water-quality. *Hydrological Processes*, *35*(3), e14098.
- Willis, T. D., & Klaar, M. J. (2021). *NFM Calderdale Summary Modelling Report*. Available at: <https://icasp.org.uk/projects-2-2/calderdale-nfm-2/>: iCASP. [Accessed 16/02/2022]
- Wolstenholme, J. M., Smith, M. W., Baird, A. J., & Sim, T. G. (2020). A new approach for measuring surface hydrological connectivity. *Hydrological Processes*, *34*(3), 538-552.
- Zhang, J., Zhang, S., Chen, S., Liu, M., Xu, X., Zhou, J., . . . Wang, C. (2021). Overland flow resistance law under sparse stem vegetation coverage. *Water*, *13*(12), 1657.

## Appendix A. Supporting Information for Chapter Two

### A.1 Soil properties data

This supplementary material to Chapter Two shows the relationship between soil properties. The soil properties chosen are as follows:

*TOM*: Total Organic Matter, %

*K<sub>s</sub>*: Saturated hydraulic conductivity, m day<sup>-1</sup>

Bulk density, g cm<sup>-3</sup>

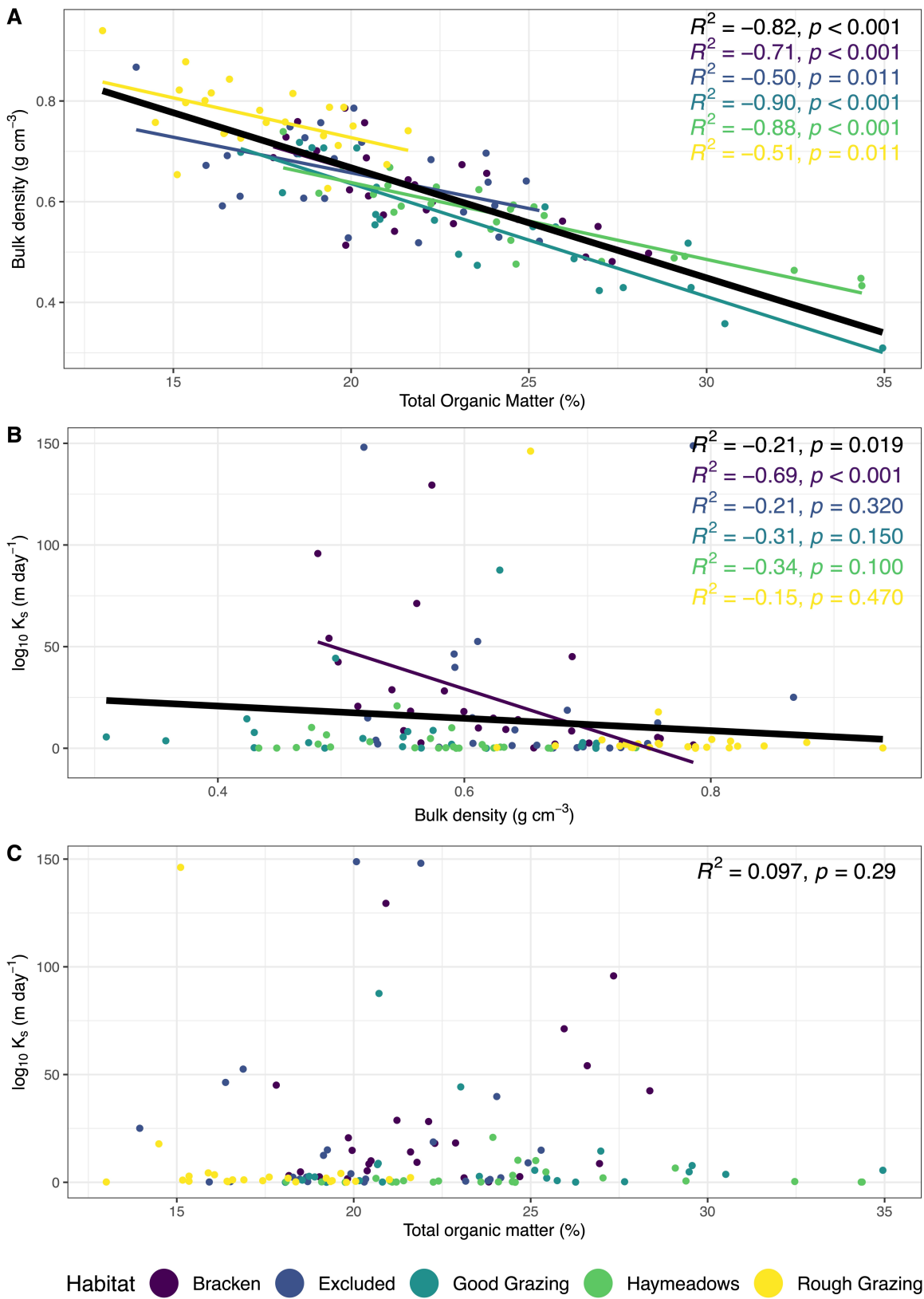

Figure A1.1: The correlation between soil properties including the correlation coefficient,  $R^2$  and the Spearman's rank  $p$  value. Plot A is the relationship between TOM and bulk density, plot B is the relationship between bulk density and  $K_s$ , and plot C is the relationship between TOM and  $K_s$ . Colours used differentiate habitat type. Black line is drawn for cases where there is a significant correlation across the entire dataset.



## A.2 List of abbreviations used in Chapter Two

Throughout Chapter Two abbreviations are used. The tables below (A2.1 & A2.2) summarise these abbreviations. The locations for which the habitat abbreviations refer are shown in Figure 2.2 in the main text.

*Table A2.1: Abbreviations used in Chapter Two*

<b>Abbreviation</b>	<b>Full form</b>
HLS	Higher Level Stewardship
$K_s$	Saturated hydraulic conductivity
NFM	Natural flood management
OLF	Overland flow
OM	Organo-mineral (soils)
SM	Soil moisture
TOM	Total organic matter

*Table A2.1: Habitat abbreviations used in Chapter Two*

<b>Habitat type</b>	<b>Abbreviation</b>	<b>Additional Information</b>
Bracken	B	Refers to whole habitat
	B1	SM sensor location 1
	B2	SM sensor location 2
Excluded	E	Refers to whole habitat
	E1	SM sensor location 1
	E2	SM sensor location 2
	E3	SM sensor location 3
	E4	SM sensor location 4
Good Grazing	GG	Refers to whole habitat
	GG1	SM sensor location 1
	GG2	SM sensor location 2
	GG3	SM sensor location 3
Rough Grazing	RG	Refers to whole habitat
	RG1	SM sensor location 1
	RG2	SM sensor location 2

### A.3 Soil moisture data

The following graphs present the temporal distribution of soil moisture data for the Upper (Figure A3.1) and Lower (Figure A3.2) hillslope locations. A summary of the mean, standard deviation and number of records of soil moisture measured as part of the matched records analysis and as part of the complete dataset (May 2019 to March 2020) is shown in Table A3.1.

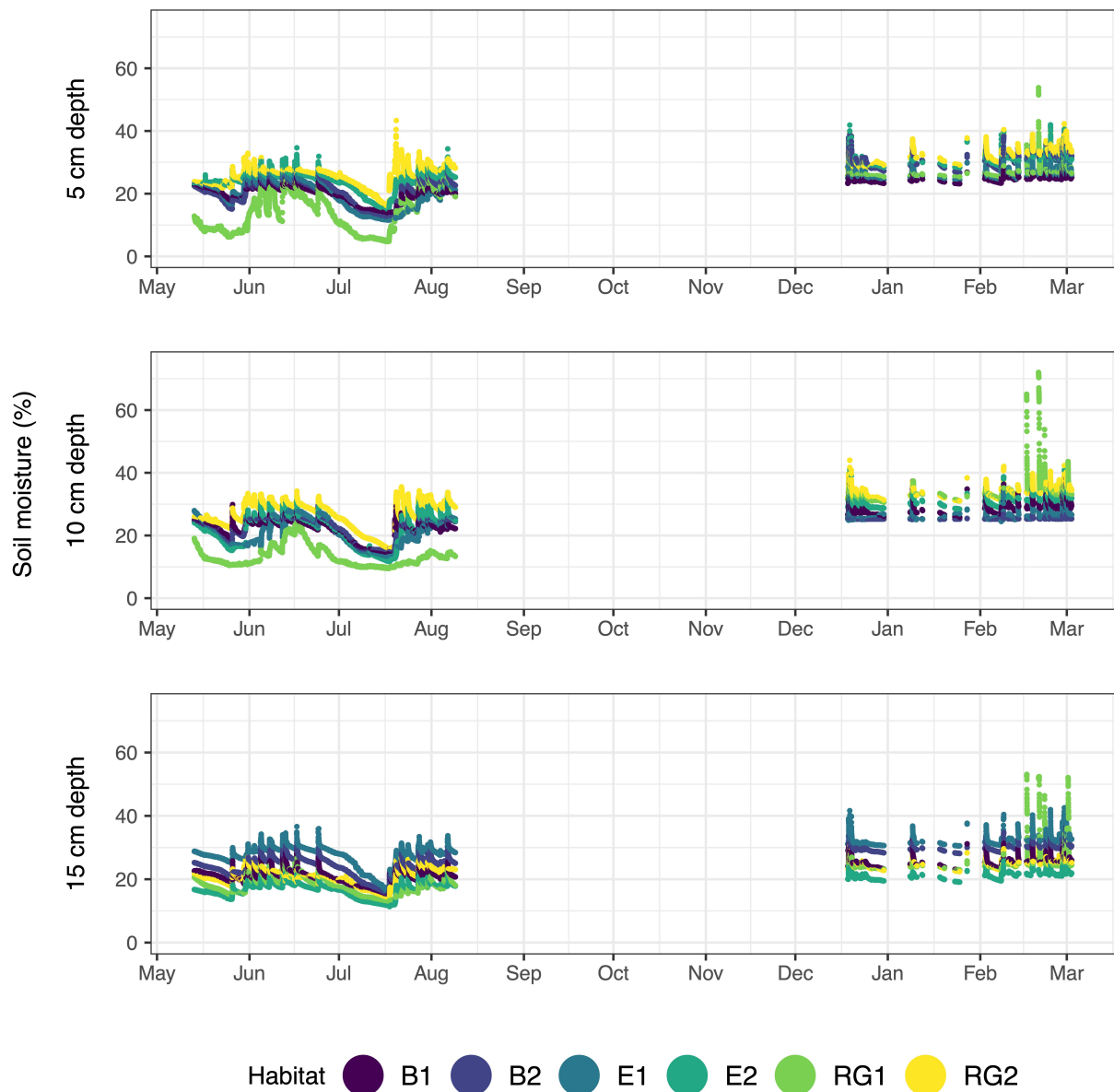

Figure A3.1: Soil moisture separated by sensor depth and habitat for the Upper Slope site

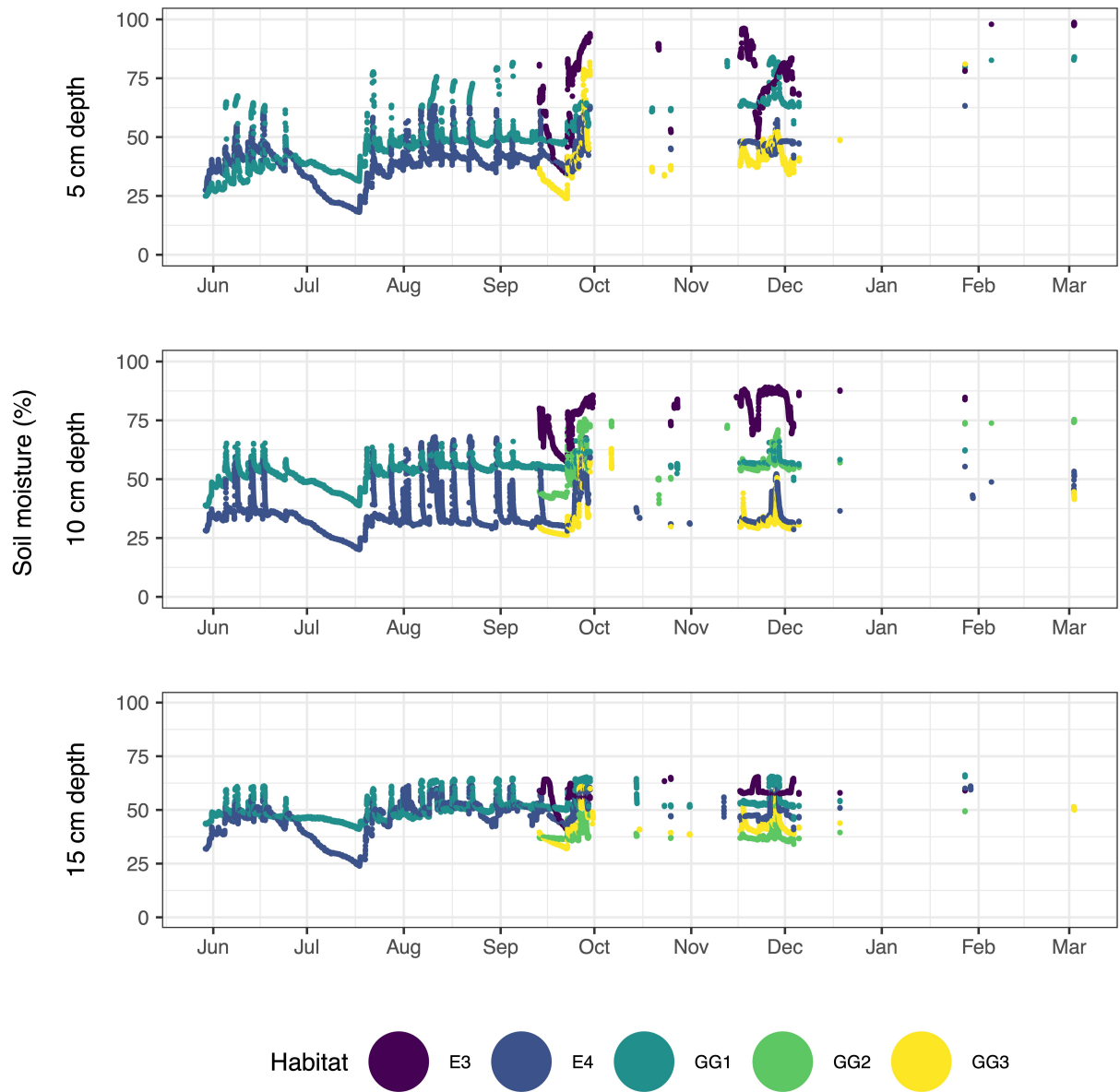

Figure A3.2: Soil moisture separated by sensor depth and habitat for the Lower Slope site

Table A3.1: Mean, standard deviation and number of records of soil moisture measured as part of the matched records analysis and as part of the complete dataset (May 2019 to March 2020)

			Matched records analysis Upper Slope: 9526 records, 808.4 mm rainfall Lower Slope: 3180 records, 246.6 mm rainfall		All Data (May 2019-March 2020) Total possible records: 26704			
Slope	Habitat	Depth	Mean soil moisture (%)	Standard deviation	Mean soil moisture (%)	Standard deviation	Timesteps	
							n	% of total possible
Upper Slope	B1	5	21.1	3.40	21.1	3.40	9887	37.0
		10	23.8	4.32	23.8	4.33	9885	37.0
		15	22.0	3.05	22.0	3.06	9879	37.0
	B2	5	23.8	5.67	23.8	5.69	9879	37.0
		10	23.3	3.36	23.2	3.36	9876	37.0
		15	25.8	3.93	25.8	3.94	9875	37.0
	E1	5	21.4	5.07	21.4	5.08	9865	37.0
		10	22.7	4.66	22.7	4.67	9889	37.0
		15	28.8	3.93	28.8	3.94	9889	37.0
	E2	5	25.9	4.27	25.9	4.28	9873	37.0
		10	24.7	5.83	24.7	5.84	9870	37.0
		15	18.2	2.88	18.2	2.88	9868	37.0
	RG1	5	18.8	7.32	18.8	7.33	9890	37.0
		10	19.9	9.91	19.9	9.90	9889	37.0
		15	20.3	4.61	20.3	4.66	9888	37.0
	RG2	5	27.6	3.97	27.6	3.99	9889	37.0
		10	28.9	5.05	28.9	5.06	9889	37.0
		15	22.1	2.96	22.1	2.96	9889	37.0
Lower Slope	E3	5	69.2	17.8	69.6	17.8	3242	12.1
		10	77.4	9.33	77.5	9.27	3247	12.1
		15	56.9	5.26	56.9	5.25	3197	12.0
	E4	5	45.0	4.82	39.6	8.23	13456	50.4
		10	35.3	7.29	34.5	8.17	13549	50.7
		15	48.8	4.22	46.3	7.96	13471	50.4
	GG1	5	39.3	8.95	39.3	8.90	3218	12.1
		10	32.2	7.68	32.4	7.91	3228	12.1
		15	41.5	6.57	41.6	6.55	3265	12.2
	GG2	5						
		10	53.4	7.87	53.7	8.14	3266	12.2
		15	38.0	3.44	38.0	3.44	3225	12.1
	GG3	5	60.2	9.62	48.1	12.3	13509	50.6
		10	57.1	2.32	53.7	4.92	13482	50.5
		15	54.4	4.77	50.6	5.32	13506	50.6

## A.4 Rainfall and overland flow data

Table A4.1: Rainfall and percentage presence of overland flow for the whole dataset and within the matched-records analysis

Slope position	Habitat	All Dates			Matched-records analysis							
		Total rainfall per habitat operational period (mm)	Total time overland flow sensor was operational (%)	Total time overland flow was present in its operational period (%)		Total	June	July	Aug	Dec	Jan	Feb
					Timesteps (n, % of total possible timesteps for months represented)	11054 (62.9%)	2144 (74%)	2976 (100%)	140 (4.7%)	1296 (43.5%)	2976 (100%)	1522 (54.7%)
					Rain (mm) recorded	1162	97.4	227.4	0	86.4	434.6	326.8
	OLF presence (%)	Below: overland flow presence per month as a percentage of total OLF presence (%) i.e., Relative percentage of overland flow per month										
Upper	E1	3173.9	90.9	39.0		14.4	15.8	63.3	6.8	5.7	8.1	0
Upper	RG1	3351.8	98.9	2.31		2.66	2.4	8.2	0	3.7	34.4	51.4
Upper	RG2	2348.0	65.1	3.97		1.00	0	27.9	0	0	16.1	55.8
Upper	B1	1345.2	27.0	0.01								
Upper	B2	2976.8	84.5	19.8		9.21	0	44.8	9.2	10.3	17.3	18.4
Upper	E2	2920.2	94.0	40.2		35.7	3.4	0.9	0	12.5	45.8	37.3
Lower	E3	3427.6	99.2	57.0		74.7	8.3	22.3	0.9	14.8	35.4	18.4
Lower	GG1	2976.0	84.5	8.60		9.99	0	26.0	3.6	10.9	29.3	30.2
Lower	GG2	2434.8	69.0	32.7		29.4	0.9	0.9	0	10.4	55.9	31.9
Lower	GG3	2299.6	66.1	60.0		68.2	2.0	21.5	0	16.0	39.5	20.2
Lower	E4	2798.4	76.6	40.0		48.8	0.2	9.3	1.1	11.8	54.1	23.7

## Appendix B. Supporting Information for Chapter Three

### B.1 List of abbreviations used in Chapter Three

$A$	Empirically derived constant
$B$	Empirically derived constant
$d$	Flow depth (m)
$\bar{d}$	Mean flow depth (m)
$f$	Darcy-Weisbach roughness
$g$	Gravitational acceleration constant
$k$	Equivalent grain roughness
$k^*$	Relative roughness
$l$	Flume length (m)
$Q$	Flow rate ( $\text{m}^3 \text{s}^{-1}$ )
$Re$	Reynolds number
$S$	Slope ( $\alpha$ )
$t$	Time difference in seconds from the point of Rhodamine injection (s)
$Vq$	The SEVolt above the limit of quantification (LoQ). Fluorescence was measured in SEvolts
$w$	Flume width (m)
$\nu$	kinematic viscosity, $1.307 \times 10^{-6} \text{ m}^2 \text{ s}^{-1}$ at $10^\circ\text{C}$
$V$	Velocity (m/s)
$\bar{V}$	Mean velocity (m/s)

## B.2 Vegetation surveys

Vegetation surveys were conducted between April and June 2019, assessing vegetation species and abundance using a 1 m<sup>2</sup> surveying quadrat. A random sampling approach was used, taking into account locations across all habitats. Each habitat was subject to at least three quadrat surveys and where a species had less than 5% abundance, it was categorised as occurring frequently, occasionally or rarely. Throughout all surveys, grazing in the Low-density grazing habitat made vegetation identification difficult where flow and seed heads were frequently missing.

Table B2.1 shows a list of all species found and their mean average abundance per habitat. Where there was a significant range in species abundance (>20% difference between quadrats), the range is given.

Table B2.1: Species present and their mean abundance for Hay meadows, Rank Grassland and Low-density grazing in Swindale, UK. Species presence only is shown for the Rushes (*Juncus effusus*) habitat which occurred within the Low-density grazing and Hay meadows habitats but which was not surveyed as 'part of' the habitat, being categorised as its own independent habitat in this study. P = Presence, A = abundance (%) and S is the abundance status if A<5% where F = Frequent, O = Occasional and R = Rare. All abundance and abundance statuses were attributed by the vegetation surveyors based on 1m<sup>2</sup> quadrats.

Category	Common name	Latin name	Haymeadows			Rank Grassland			Low-density grazing			Rushes
			P	A (%)	S if <5%	P	A (%)	S if <5%	P	A (%)	S if <5%	P
Broadleaf	Birdsfoot trefoil	<i>Lotus corniculatus</i>		<5	R							
Broadleaf	Broadleaf plantain	<i>Plantago major</i>		5								
Broadleaf	Bulbus buttercup	<i>Ranunculus bulbosus</i>		<5	R					<5	O	
Broadleaf	Cats ear	<i>Hypochaeris radicata</i>		<5	R							
Broadleaf	Common daisy	<i>Bellis perennis</i>		5								
Broadleaf	Cow parsely	<i>Anthriscus sylvestris umbellifus</i>		<5	R							
Broadleaf	Creeping buttercup	<i>Ranunculus repens</i>		<5	R		15			<5	R	
Broadleaf	Dandelion	<i>Taraxacum officinalis agg.</i>		<5	R					<5	R	
Broadleaf	Eyebright	<i>Euphrasia app.</i>		5	O							
Broadleaf	Field woodrush	<i>Luzula campestris</i>								10		
Broadleaf	Forget-me-not	<i>Myosotis spp.</i>		<5	R							
Broadleaf	Germander speedwell	<i>Veronica chaemedrys</i>					<5	R		<5	R	
Broadleaf	Greater birdsfoot trefoil	<i>Lotus pedunculatus</i>					15					
Broadleaf	Lesser celandine	<i>Ranunculus ficaria</i>					<5	O		<5	R	
Broadleaf	Lesser trefoil	<i>Trifolium dubium</i>		15-40								
Broadleaf	Meadow buttercup	<i>Ranunculus acris</i>		5			10			<5	O	
Broadleaf	Mouse ear	<i>Ceratium fantanum</i>		<5	R					<5	R	
Broadleaf	Pignut	<i>Conopodium majus</i>		<5	F		<5	R		<5	R	
Broadleaf	Ragwort	<i>Senecio jacobaea</i>								<5	R	
Broadleaf	Red clover	<i>Trifolium pratense</i>		10								



Broadleaf	Ribwort plantain	<i>Plantago lanceolata</i>		10								
Broadleaf	Sheep's sorrel	<i>Rumex acetosella</i>		5			15			<5	F	
Broadleaf	White clover	<i>Trifolium repens</i>		<5	O					5		
Broadleaf	Wood cranesbill	<i>Geranium sylvaticum</i>		<5	O							
Broadleaf	Yellow rattle	<i>Rhinanthus minor</i>		15								
Grasses	Cocks foot	<i>Dactylis glomerta</i>					20					
Grasses	Common bentgrass	<i>Agrostis capillaris</i>		<5	O		5			30		
Grasses	Creeping bentgrass	<i>Agrostis stolonifera</i>					<5		O			
Grasses	Crested dogs tail	<i>Cynosurus cristatus</i>		10						20		
Grasses	Meadow fescue	<i>Festuca pratensis</i>		<5	O		<5		F	50-75		
Grasses	Meadow foxtail	<i>Alopecurus pretensis</i>		<5	R							
Grasses	Meadowgrass	<i>Poa spp.</i>					<5		R	<5		
Grasses	Red fescue	<i>Festuca rubra</i>					25					
Grasses	Sheep's fescue	<i>Festuca ovina</i>		5			25			50-75		
Grasses	Sweet vernal grass	<i>Anthoxanthum odoratum</i>		10			15			5		
Grasses	Perennial rye grass	<i>Lolium perenne</i>								<5	O	
Grasses	Yellow oat grass	<i>Trisetum flavescens</i>		<5	O							
Grasses	Yorkshire fog	<i>Holcus lanatus</i>		20-40			5-30			5		
Litter	All species, unidentifiable vegetation litter						80 (winter only)					
Mosses	Common feather moss	<i>Kindbergia praelonga</i>		<5	R					<5	O	
Mosses	Fern-leaved hook moss	<i>Cratoneuron filicinum</i>		<5	R					<5	O	
Mosses	Springy turf moss	<i>Rhytidiadelphus squarrosus</i>		<5	R					20-75		
Rushes	Sharp-flowered rush	<i>Juncus acutiflorus</i>					10					
Rushes	Soft rush	<i>Juncus effusus</i>										

### B.3 Rhodamine concentration and fluorometer breakthrough curves

Rhodamine water tracing (WT) dye was used to measure overland flow velocity, and to calculate Darcy-Weisbach roughness and effective roughness,  $k^*$ , using equations 3.1-3.12. For all three flow rates, 12 L/min, 6 L/min and 1.2 L/min, the same Rhodamine concentration was injected into the applied flow. This concentration was a 100  $\mu$ L slug of a 100 ppb Rhodamine in deionised water solution.

The fluorometer, which measures fluorescence from the rhodamine dye, records response in SEVolts. It was essential to find a 'slug' concentration which produced a <30 ppb in-flume concentration (as agreed with United Utilities, the landowners) and which was high enough to produce a viable breakthrough curve above the limit of quantification (LoQ).

LoQ was calculated using equation B3.1:

$$LOQ = (10 SE) + \overline{SEV} \quad B3.1$$

where SE is the standard error of SEVolts and  $\overline{SEV}$  is the mean average of SEVolts.

To reduce environmental risk, the lowest accurate rhodamine concentration range was chosen. Laboratory tests determined the range of concentrations suitable; standards testing of the fluorometer showed high-accuracy between 0.001 and 0.014 ppb (~275-980 SEVolts, Figure B3.1). Following standards testing, a laboratory-based flume recorded smooth breakthrough curves for a variety of rhodamine concentrations. From these, a 100 ppb concentration was chosen for field tests from which the volume could be altered to establish a final slug injection volume.

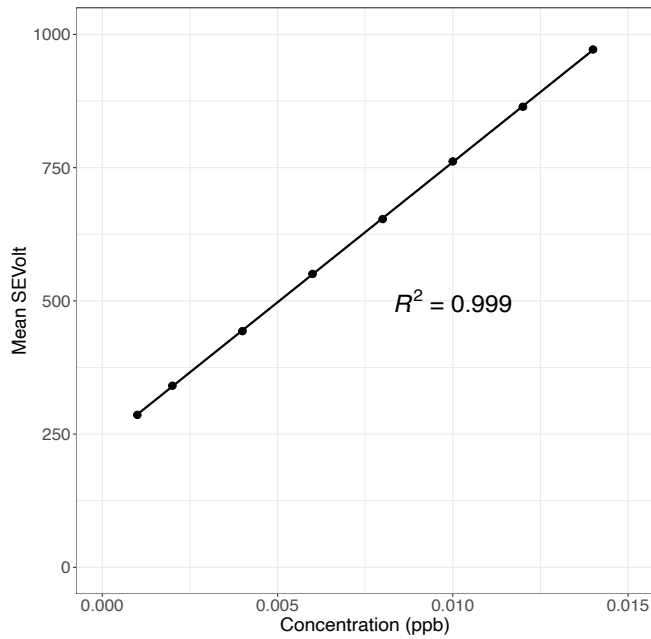

Figure B3.1: Standards concentration of rhodamine dye in deionised water

Field tests were undertaken at Boddington Playing Fields, University of Leeds, using 12 L/min and 1.2 L/min flow rates. These tests established that a 100  $\mu$ L injection of a 100 ppb concentration was visible and produced smooth breakthrough curves up to a maximum  $\sim$ 1200 SEVolts for all flow rates. When applied in Swindale, 96.6% of values measured were between 275 and 980 SEVolts ( $\sim$ 0.001-0.014 ppb), the same range measured in laboratory standards testing (Figure B3.1). Mean LoQ in Swindale was 242.8 SEVolts (0.00016 ppb).

SEVolt peak varied based on flow rate (rhodamine dilution), the fluorometer sensor cleanliness and sediment concentrations in the water, where water was pumped into the bowser from nearby streams. However, since calculations of mean flow velocity and Darcy-Weisbach roughness were made based on the timing of change in fluorescence from baseline to peak (equations 3.1-3.4), the initial baseline and height of peak is irrelevant. The time to peak is the most important variable. However, the fluorometer was cleaned regularly to ensure no imposed error and to ensure, as much as possible, a clear breakthrough curve. Figure B3.2 shows examples of breakthrough curves for each flow rate from the November data collection.

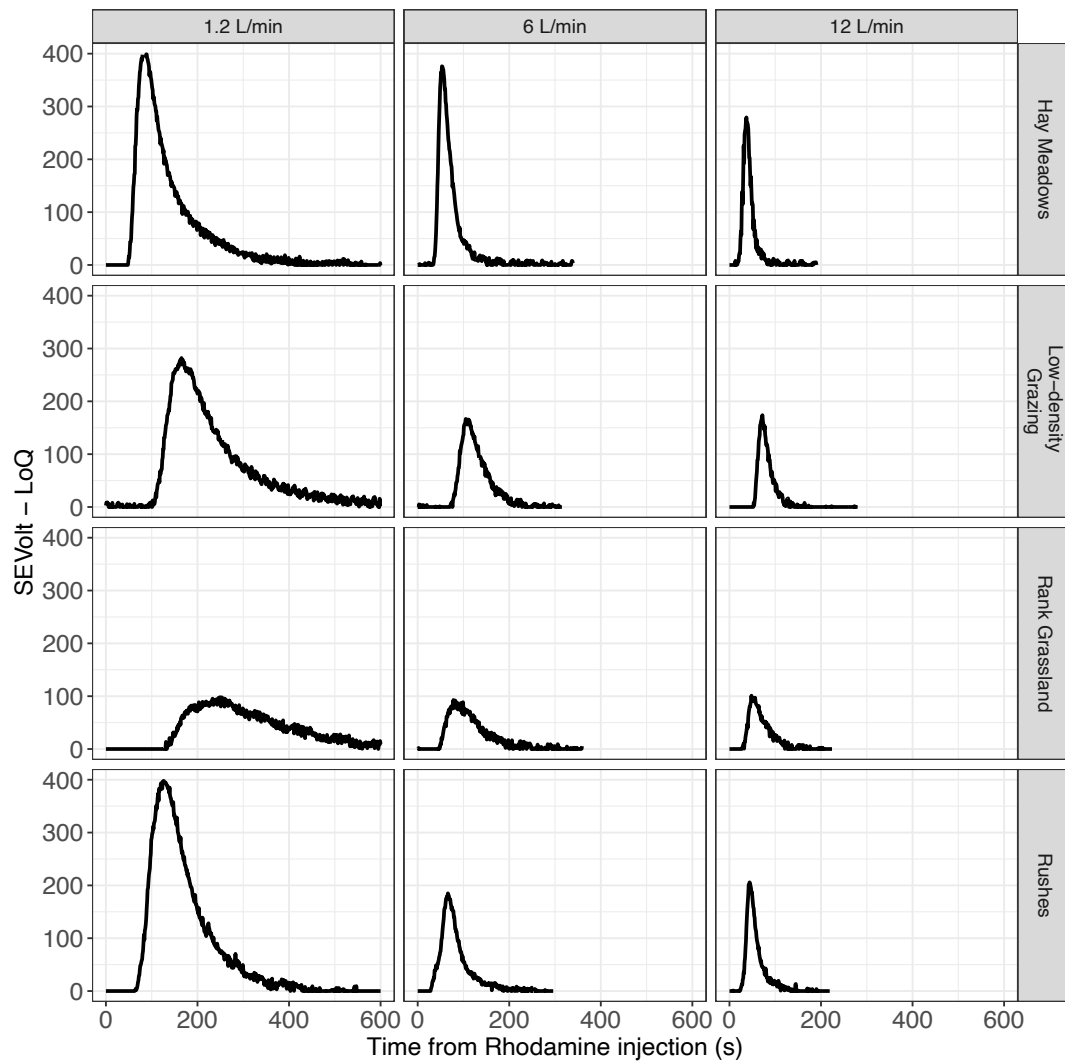

Figure B3.2: Example breakthrough curves for each flow rate from the November data collection. Each curve represents one rhodamine injection into the flume and has a unique LoQ calculated from equation B3.1

## Appendix C. Supporting Information for Chapter Four

### C.1 SD-TOPMODEL parameter derivation

The following describes how SD-TOPMODEL parameters are derived from field data.

#### Parameters

SD-TOPMODEL has three primary parameters which can be input at the cell scale to represent the catchment:

- 4)  $K$ , the hydraulic conductivity of the soil;
- 5)  $m$ , a scaling factor which controls the decrease of transmissivity with depth and the shape of the hydrograph recession, representing active water storage within the soil;
- 6)  $K_v$ , an overland flow velocity parameter which is related to surface roughness.

A fourth parameter, Interception,  $I_n$ , is an additional feature to SD-TOPMODEL, created by Boisgontier (2018), which can also be fully spatially distributed using a parameter map at the cell scale. This was used for both Swindale and Calderdale.

Parameter values for each scenario can be found in Appendix C2 for Swindale and Appendix C3 for Calderdale.

#### **$K$ , the hydraulic conductivity of the soil**

The rate of movement of water into soils is partially determined by the hydraulic conductivity,  $K$  ( $\text{m s}^{-1}$ ). Discharge,  $Q$  ( $\text{m}^3 \text{s}^{-1}$ ), is assumed to be proportional to the driving force which is equal to the negative hydraulic head gradient,  $\nabla H$  (dimensionless, vector quantity, equation C1.1).

$$\nabla H = \frac{\Delta h}{\Delta l} \quad (\text{C1.1})$$

where  $\Delta h$  is the height difference between two hydraulic heads (m) and  $l$  is the distance over which flow occurs (m).

The proportionality factor, which relates the flux density and driving forces in the hydraulic conductivity, where  $\nabla H$  is positive in flow direction, is defined by Darcy's Law, equation C1.2;

$$Q = KA \cdot \nabla H \quad (C1.2)$$

where  $A$  is the cross-sectional area perpendicular to flow ( $m^2$ ).

$K$  varies between soils depending on clay content, particle size, particle orientation, organic matter content and water content (Dane *et al.*, 2006). Often,  $K$  is difficult to measure *in situ* as it varies with antecedent conditions, therefore the saturated hydraulic conductivity,  $K_s$ , is used as a proxy for  $K$  in SD-TOPMODEL. When soils are saturated, all pores are filled and conducting water, therefore conductivity is maximised.

$K_s$ , equation C1.3, can be directly derived from Darcy's law:

$$K_s = \frac{Q \cdot l}{A \cdot \nabla H} \quad (C1.3)$$

where  $K_s$  is the saturated hydraulic conductivity ( $m \cdot s^{-1}$ ).

### **$m$ , representing active water storage in the soil**

$m$  (mm), describes the active water storage of the soil and is calculated for each catchment. Because of this,  $m$  is a lumped parameter and unsuitable for spatial distribution.  $m$  itself is not the absolute storage of water in soil per catchment area but rather a scaling factor which represents the relationship between soil depth and storage where  $m$  multiplied by  $K$  is the transmissivity. As in the original TOPMODEL (Beven and Kirkby, 1979), an assumption is made in SD-TOPMODEL that the "*distribution of downslope transmissivity with depth is an exponential function of storage deficit or depth to the water table*" (Beven, 2011, p. 191); therefore  $m$  is the rate of decline of hydraulic conductivity in the soil profile which can be said to control the effective depth of active water storage (Beven, 2011). This is described in equation C1.4:

$$K = K_* e^{-\frac{D}{m}} \quad (C1.4)$$

where  $K$  is the hydraulic conductivity at the soil moisture deficit,  $D$ , and  $K_*$  is the hydraulic conductivity at the surface.

During a recession period, assuming zero precipitation and evapotranspiration,  $m$  is related to discharge (equation C1.5):

$$\frac{\delta j}{\delta t} = \frac{-j^2}{m} \quad (C1.5)$$

where  $j$  is the discharge per unit catchment area (specific discharge, mm) and  $t$  is time (days). This can be re-written as

$$-\frac{i}{j} \cdot \frac{dj}{dt} = \frac{j}{m} \quad (C1.6)$$

where  $i$  is net rainfall, assumed to be zero during dry winter recession periods when evapotranspiration is negligible. Plotting, for suitable recession periods,  $-1/j \, dj/dt$  against  $j$  should therefore give a straight line, with gradient  $1/m$ , and this provides a means of both confirming the relevance of the TOPMODEL assumptions and estimating the value of the scaling parameter,  $m$ .

### **$K_V$ , an overland flow velocity parameter which is related to surface roughness**

$K_V$ , which describes surface roughness, is a dimensionless parameter based the Darcy Weisbach equation (Equation C1.7). It describes the relationship between the mean overland flow velocity,  $\bar{V}$  ( $\text{m s}^{-1}$ ), overland flow depth,  $d$  (m), surface slope,  $S$  ( $\text{m m}^{-1}$ ), gravitational acceleration,  $g$ , and the dimensionless friction factor, Darcy-Weisbach roughness,  $f$ .

$$\bar{V}^2 = \frac{8g}{f} dS \quad (C1.7)$$

$f$  and  $d$  can be related to effective roughness length,  $k$ , using Equation C1.8:

$$\frac{1}{\sqrt{f}} = A + 1.77 \ln\left(\frac{d}{k}\right) \quad (C1.8)$$

where  $A$  is an empirically defined constant.

Over the range  $10 < d/k < 10,000$ , equation (C1.8) is adequately approximated by the power law  $f^{-0.5} \sim (d/k)^{1/6}$ , and then reduces to Manning's equation:

$$n = \frac{d^{2/3} \cdot S^{1/2}}{V} \quad (C1.9)$$

where  $V$  ( $\text{m s}^{-1}$ ) is the velocity and  $n$  is Manning's  $n$  ( $\text{s m}^{-1/3}$ ).

Gao *et al.* (2015) used Manning's equation to relate overland flow velocity to depth and slope gradient, in the form of Equation C1.10:

$$V = K_v \cdot d^{2/3} \cdot S^{1/2} \quad (C1.10)$$

in which

$$K_v = \frac{1}{n} \quad (C1.11)$$

### **$I_n$ , Interception**

Interception map input values are calculated using Equation C1.12:

$$In_V = 1 - \left(\frac{In_P}{100}\right) \quad (C1.12)$$

where  $In_V$  is the map input value and  $In_P$  is the reduction in percentage interception. If there is no interception,  $In_V$  equals 1.



## References

- Beven, K., & Kirkby, M. (1979). A physically based, variable contributing area model of basin hydrology/Un modèle à base physique de zone d'appel variable de l'hydrologie du bassin versant. *Hydrological Sciences Journal*, 24(1), 43-69.
- Beven, K. J. (2011). *Rainfall-runoff modelling: the primer*. Chichester, UK: John Wiley & Sons.
- Boisgontier, H. (2018). *Modelling the potential of natural flood management practices in an upland peatland catchment with the distributed TOPMODEL*. (Masters by Research), University of Leeds.
- Dane, J. H., Jalbert, M., & Hopmans, J. W. (2006). Hydraulic conductivity. In R. Lal (ed.), *Encyclopaedia of soil science second edition*. New York: Taylor and Francis.
- Gao, J., Holden, J., & Kirkby, M. (2015). A distributed TOPMODEL for modelling impacts of land-cover change on river flow in upland peatland catchments. *Hydrological Processes*, 29(13), 2867-2879.

## C.2 Swindale land uses and model parameters

Appendix C2 describes the land covers in Swindale, including their broad management and dominant vegetation types, and the calculation process for  $K_v$ ,  $K$  and  $m$  parameters for the seasonality (S1) and management (S2) scenarios modelled.

In the following paragraphs, abbreviations will be used to refer to individual land cover types within the Swindale catchment. B = Bracken, C = Crag, GG = Good Grazing, HM = Hay Meadows, MC = Mardale Common, MD = Mosedale, RG = Rank Grassland, RRC = Rosgil and Ralfland Common, RoG = Rough Grazing, R = Rushes, S = Scree and UR = Urban and Roads.

Table C2.1: Land covers in Swindale

Land cover (abbreviation)	Description
Mosedale (MD)	Hill land, ungrazed by sheep but subject to deer grazing
Rosgil & Ralfland Common (RRC)	Commons land, ungrazed by sheep but subject to deer grazing
Mardale Common (MC)	Grazed common land. Approximately 0.12 livestock units per hectare
Rank Grassland (RG)	Dominated by tall, tussocky and coarse grass species. Produced in unmanaged, ungrazed grasslands. Dominant species include: <i>Dactylis glomerata</i> , <i>Holcus lanatus</i> , <i>Agrostis capillaris</i> , <i>Anthoxanthum odoratum</i> , <i>Festuca spp.</i> , <i>Ranunculus repens</i> , <i>Lotus pedunculatus</i> , and <i>Ranunculus acris</i>
Bracken (B)	<i>Pteridium aquilinum</i> ferns native to the UK
Improved grassland (Rough grazing, RoG)	Good Grazing and Rough Grazing are both low-density, improved grassland land covers which have been given the grade of 'Good' or 'Rough' based on the quality of fodder and the extent to which the sward is allowed to grow before grazing. Approximately 0.21 livestock units per hectare. Rough grazing is situated on the higher, steeper slopes. Dominant species include: <i>Festuca ovina</i> , <i>Agrostis spp.</i> and <i>Cynosurus cristatus</i> , <i>Rhynchodesperma squarrosus</i> , <i>Trifolium repens</i> , <i>Luzula campestris</i> and <i>Rumex acetosella</i> .
Improved grassland (Good grazing, GG)	Species rich grassland for which no single species dominates. Species include: <i>Holcus lanatus</i> , <i>Anthoxanthum odoratum</i> , <i>Cynosurus cristatus</i> , <i>Rhinanthus minor</i> , <i>Trifolium dubium</i> , <i>Trifolium pratense</i> and <i>Plantago lanceolata</i> .
Hay Meadows (HM)	
Rushes (R)	<i>Juncus effusus</i> rush swathes. Majority lie within the Improved grassland but they are unpalatable, and generally avoided by grazing animals.
Crag (C)	Steep, rugged cliff or rock face. Impermeable.
Scree (S)	Large, loose stones and rocks.
Urban & Roads (UR)	Impermeable concrete surfaces and buildings

## Baseline

The current (baseline) land cover for Swindale is shown in Figure C2.1 and a description of each land cover given in Table C2.1. This land cover is the baseline catchment layout to which all scenarios are compared. Baseline model parameters are shown in Table C2.2 and were calculated using annual average  $K_v$  values and field-measured  $K_s$  values.

All model runs except for the Swindale 24-hour, 1 in 50-year scenario, fully completed within the limited timeframe available to run each model. Peak data and the majority of the falling limb of the 24-hour, 1 in 50-year model was produced and was therefore considered sufficient enough for analysis.

### **$K_v$ , surface roughness**

Roughness values for Swindale land covers were derived from field data collected by Bond et al. (2020), Holden et al. (2008) and Monger et al. (2022). A breakdown of land covers represented by each source is given in Table 4.4 of the main text.

Velocity measurements from each field source were used to determine the relative difference between land covers to input into spatially-distributed maps. For the baseline map, the annual average value was used and the difference between land covers was calculated relative to Mosedale, the largest land cover by area. Since  $K_v$  and  $V$  are directly proportional, this was considered a reasonable substitute. All literature sources used the same applied flow rate of  $12 \text{ L min}^{-1}$  to measure overland flow velocity. Through calibration, a final parameter file value of 9 was chosen as a best-fit  $K_v$ .

### **K, the permeability**

$K$  values were also derived from literature and the sources per land cover are given in Table 4 of the main text. A parameter file value of  $K = 6.214608$  ( $K_s = 500 \text{ m h}^{-1}$ ) was derived through model calibration. The parameter file value represents a scaling factor. Gao et al. (2015) recommend for peat soils a model  $K_s$  value of  $100\text{-}300 \text{ m h}^{-1}$ . Since much of Swindale is underlain by blanket peat or highly permeable, shallow, organo-mineral soils with shale underneath (Bond et al., 2021), a value of  $K_s = 500 \text{ m h}^{-1}$  was considered acceptable.

**m, the active storage**

*m* is calculated at the catchment scale, therefore the SD-TOPMODEL parameter file value, *m* = 0.008, was calculated through calibration alone. In all scenarios, the parameter file value was 0.008 and the *m* map value was 1.

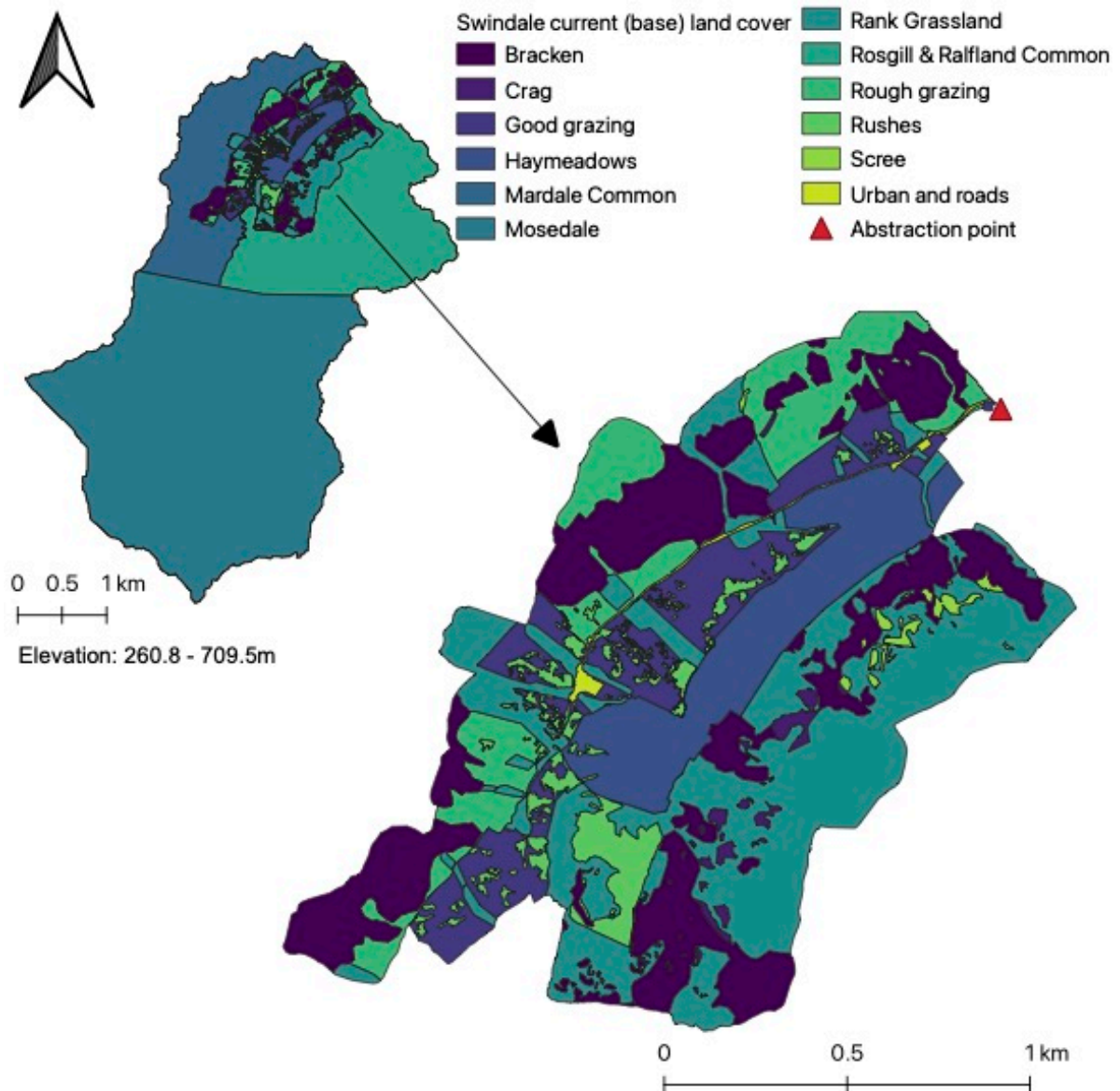

Figure C2.1: Baseline land cover for Swindale

Table C2.2: Baseline map parameter values for each land cover in Swindale.

Land Use	Kv, Roughness		K, Hydraulic Conductivity		m, Active Storage	
	Parameter file value, Kv = 9		Parameter file value = 6.214608 (Ks = 500 m h <sup>-1</sup> )		Parameter file value = 0.008 m	
	Measured velocity, m s <sup>-1</sup>	Relative value (to Mosedale)	Measured Ks, m hr <sup>-1</sup>	Relative value (to Mosedale)	Measured value, m	Map value
Bracken	0.0380	1.6393	0.4154	0.2308	19.8	1
Crag	0.0504	2.1726	0.0010	0.0006		
Good Grazing	0.0289	1.2468	0.0128	0.0071		
Haymeadows	0.0409	1.7632	0.1143	0.0635		
Mardale Common	0.0232	1.0000	1.8000	1.0000		
Mosedale	0.0232	1.0000	1.8000	1.0000		
Rank Grassland	0.0257	1.1087	0.0993	0.0551		
Rosgill & Ralfland Common	0.0232	1.0000	1.8000	1.0000		
Rough Grazing	0.0273	1.1788	0.0470	0.0261		
Rushes	0.0320	1.3805	0.0754	0.0027		
Scree	0.0504	2.1726	0.0010	0.0006		
Urban and Roads	0.0504	2.1726	0.0010	0.0006		

## Scenario one: seasonality

### *K<sub>v</sub>*, surface roughness

To represent season in Swindale, only *K<sub>v</sub>* was changed per scenario (April to November), maintaining baseline *K*, *m* and catchment configuration. The relative-velocity map values and *K<sub>v</sub>* parameter file value are shown in Table C2.3. For all scenarios, the parameter file values were *K<sub>v</sub>* = 9, *K* = 6.214608 and *m* = 0.008.

Seasonal data were available for the GG, HM, RG and R land covers, and seasonality could be estimated for RoG as an average between RG and GG land covers (Bond et al., 2020). Since seasonal data were not available from Holden et al. (2008) or Monger et al. (2022), it was assumed that velocities recorded were equivalent to annual average values. To test the seasonal influence of *K<sub>v</sub>* on flood peak and timing, seasonal change in velocity had to be estimated for land covers without such data. To do this, the comparative change in velocity per month for each Bond et al. (2020) land cover was calculated relative to its annual average velocity. The mean monthly relative value was then used as the baseline relative difference for the land covers without seasonal values. Using this baseline, seasonal velocity could be estimated for B, MD, RRC and MC land covers. It was assumed that there was no seasonal change in *K<sub>v</sub>* for UR, S or C land covers.

After annual and seasonal velocity was determined, relative differences between land covers were calculated. For the annual average, difference between land covers was calculated relative to Mosedale, the largest land cover by area. When applying seasonal values, difference between land covers was calculated relative to each land cover's annual average velocity. The relative values were used to create spatially-distributed map files for SD-TOPMODEL using the current catchment land cover configuration.

Table C2.3: Kv parameter value and relative velocity values for each land cover in Swindale.

Land Cover	Kv, Roughness											
	Parameter file value, Kv = 9											
	Annual average (baseline)		April		June		July		Sept		Nov	
	Measured velocity, m s <sup>-1</sup>	Relative value (to Mosedale)	Velocity, m s <sup>-1</sup>	Relative value (to annual)	Velocity, m s <sup>-1</sup>	Relative value (to annual)	Velocity, m s <sup>-1</sup>	Relative value (to annual)	Velocity, m s <sup>-1</sup>	Relative value (to annual)	Velocity, m s <sup>-1</sup>	Relative value (to annual)
Mosedale	0.02318	1.00000	0.02686	1.15885	0.02343	1.01083	0.02119	0.91397	0.02188	0.94384	0.02618	1.12932
Rosgill & Ralfland Common	0.02318	1.00000	0.02686	1.15885	0.02343	1.01083	0.02119	0.91397	0.02188	0.94384	0.02618	1.12932
Mardale Common	0.02318	1.00000	0.02686	1.15885	0.02343	1.01083	0.02119	0.91397	0.02188	0.94384	0.02618	1.12932
Urban & Roads	0.05036	2.17256	0.05036		0.05036		0.05036		0.05036		0.05036	
Good Grazing	0.02890	1.24676	0.03005	1.03984	0.03149	1.08975	0.03193	1.10489	0.02336	0.80816	0.02782	0.96248
Rough Grazing	0.02732	1.17879	0.03046	1.11492	0.03061	1.12012	0.02594	0.94942	0.02496	0.91335	0.02865	1.04860
Bracken	0.03800	1.63934	0.04404	1.15885	0.03841	1.01083	0.03473	0.91397	0.03587	0.94384	0.04291	1.12932
Crag	0.05036	2.17256	0.05036		0.05036		0.05036		0.05036		0.05036	
Hay Meadows	0.04087	1.76316	0.03953	0.96719	0.02846	0.69646	0.04249	1.03962	0.05060	1.23808	0.05219	1.27695
Rank Grassland	0.02570	1.10871	0.03088	1.20146	0.02972	1.15639	0.01995	0.77638	0.02656	1.03336	0.02949	1.14742
Rushes	0.03200	1.38050	0.04707	1.47086	0.03173	0.99145	0.02239	0.69953	0.02324	0.72625	0.03876	1.21113
Scree	0.05036	2.17256	0.05036		0.05036		0.05036		0.05036		0.05036	

## Scenario two: management

Parameters  $K_v$ ,  $K$  and  $I_n$  were all used to represent management scenarios, alongside changes in catchment configuration applied to the baseline catchment grassland land cover only. Management scenarios for Swindale were considered carefully and determined after conversations with RSPB Haweswater and Natural England in Cumbria. Maps of each scenario are given in Figures C2.2 to C2.6.

In addition to the sources used to represent the baseline land cover (Table 4, main text), additional data from Herbst et al. (2006); Herbst et al. (2008), Kingsbury et al. (2021) and Monger et al. (2022) were used to provide interception ( $I_n$ ),  $K_s$  and  $K_v$  data for scrub and woodland land covers. The additional sources were chosen because the data came from similar upland land covers as those found in Swindale. The parameters applied to each spatially-distributed scenario map are given in Tables C2.3 to C2.8. As with scenario 1 above, all models are designed to be compared with the baseline model (Figure C2.1).

For all scenarios, the parameter file values were  $K_v = 9$ ,  $K = 6.214608$  and  $m = 0.008$ .



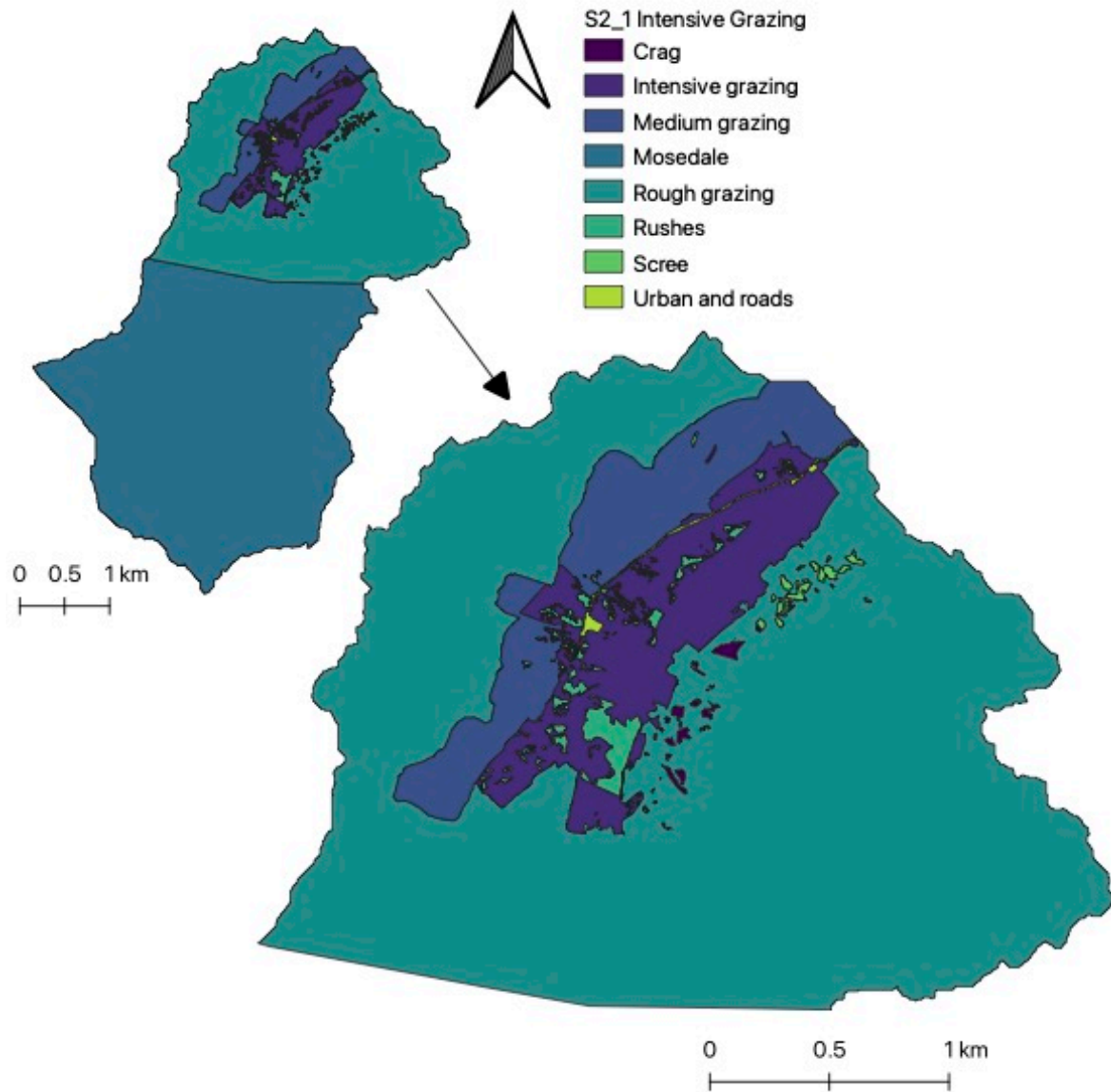

Figure C2.2: Map for Scenario S2\_1

Table C2.4: Parameters for management scenario S2\_1. Parameters are relative to the baseline value per land cover. Land covers differing from the baseline scenario are highlighted in blue.

S2_1: Revert to high intensity grazing						
Baseline Land cover	New land cover	How has the land cover changed from the baseline?	Kv		K	
			Velocity, m s <sup>-1</sup>	Relative velocity	Median K <sub>s</sub> , m hr <sup>-1</sup>	Relative K
Mosedale	Mosedale	Same as baseline	0.0232	1.0000	1.8000	1.0000
Rosgill & Ralfland Common	Rough Grazing	Convert to 'rough grazing' (annual)	0.0273	1.1788	0.0470	0.0261
Mardale Common	Rough Grazing	Convert to 'rough grazing' (annual)	0.0273	1.1788	0.0470	0.0261
Urban & Roads	Urban & Roads	Same as baseline	0.0504	2.1726	0.0010	0.0006
Good Grazing	Intensive grazing	Kv is equivalent to haymeadows roughness after cutting and with grazing (Nov). K <sub>s</sub> is haymeadows annual	0.0522	1.8058	0.1143	8.9051
Rough Grazing	Medium grazing	Kv is equivalent to good grazing (July). K <sub>s</sub> is Good Grazing annual	0.0319	1.1686	0.0128	0.2729
Bracken	Intensive grazing	Assume removed. Same the land cover they were surrounded by	0.0522	1.3734	0.1143	0.2751
Bracken	Medium grazing		0.0319	0.8403	0.0128	0.0309
Bracken	Rough Grazing		0.0273	0.7191	0.0470	0.1132
Crag	Crag	Same as baseline	0.0504	2.1726	0.0010	0.0006
Hay Meadows	Intensive grazing	Kv is equivalent to haymeadows roughness after cutting and with grazing (Nov). K <sub>s</sub> is haymeadows annual	0.0522	1.2769	0.1143	0.0635
Rank Grassland	Intensive grazing	Depending on elevation, change to grazing parameters	0.0522	2.0307	0.1143	1.1510
Rank Grassland	Rough Grazing		0.0273	1.0632	0.0470	0.4736
Rushes	Rushes	Same as baseline	0.0320	1.3805	0.0049	0.0027
Scree	Scree	Same as baseline	0.0504	2.1726	0.0010	0.0006

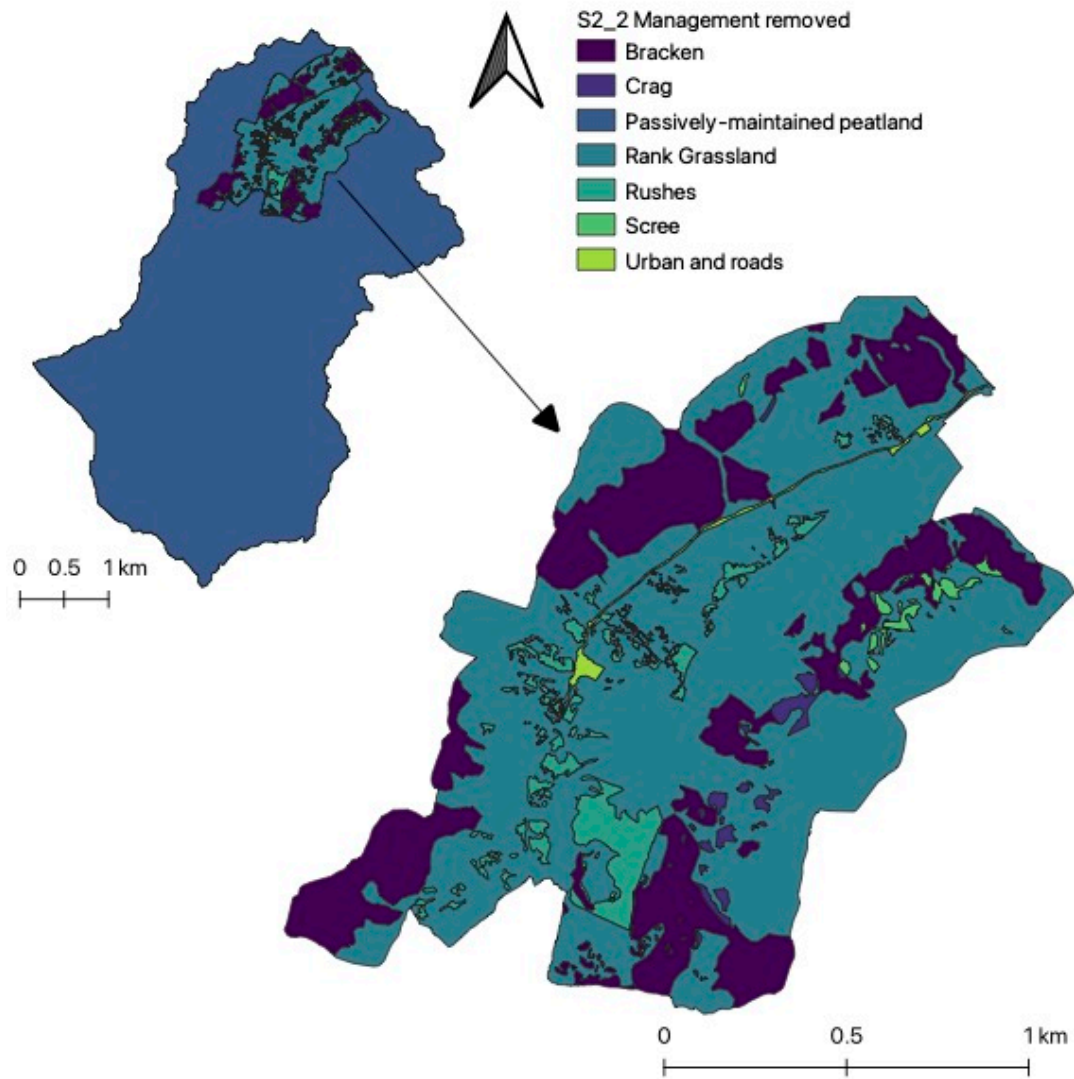

Figure C2.3: Map for Scenario S2\_2

Table C2.5: Parameters for management scenario S2\_2. Parameters are relative to the baseline value per land cover. Land covers differing from the baseline scenario are highlighted in blue.

<b>S2_2: Catchment in approximately 2 years' time if all management were removed</b>						
<b>Baseline land cover</b>	<b>New land cover</b>	<b>How has the land cover changed from the baseline?</b>	<b>Kv</b>		<b>K</b>	
			Velocity, m s <sup>-1</sup>	Relative velocity	Median K <sub>s</sub> , m hr <sup>-1</sup>	Relative K
Mosedale	Passively maintained peatland	Same as baseline	0.0232	1.0000	1.8000	1.0000
Rosgill & Ralfland Common	Passively maintained peatland	Same as baseline	0.0232	1.0000	1.8000	1.0000
Mardale Common	Passively maintained peatland	Same as baseline	0.0232	1.0000	1.8000	1.0000
Urban & Roads	Urban & Roads	Same as baseline	0.0504	2.1726	0.0010	0.0006
Good Grazing	Rank Grassland	Convert to 'rank grassland' (annual)	0.0257	0.8893	0.0993	7.7365
Rough Grazing	Rank Grassland	Convert to 'rank grassland' (annual)	0.0257	0.9406	0.0993	2.1114
Bracken	Bracken	Same as baseline	0.0380	1.6393	0.4154	0.2308
Crag	Crag	Same as baseline	0.0504	2.1726	0.0010	0.0006
Hay Meadows	Rank Grassland	Convert to 'rank grassland' (annual)	0.0257	0.6288	0.0993	0.8688
Rank Grassland	Rank Grassland	Same as baseline	0.0257	1.1087	0.0993	0.0551
Rushes	Rushes	Same as baseline	0.0320	1.3805	0.0049	0.0027
Scree	Scree	Same as baseline	0.0504	2.1726	0.0010	0.0006

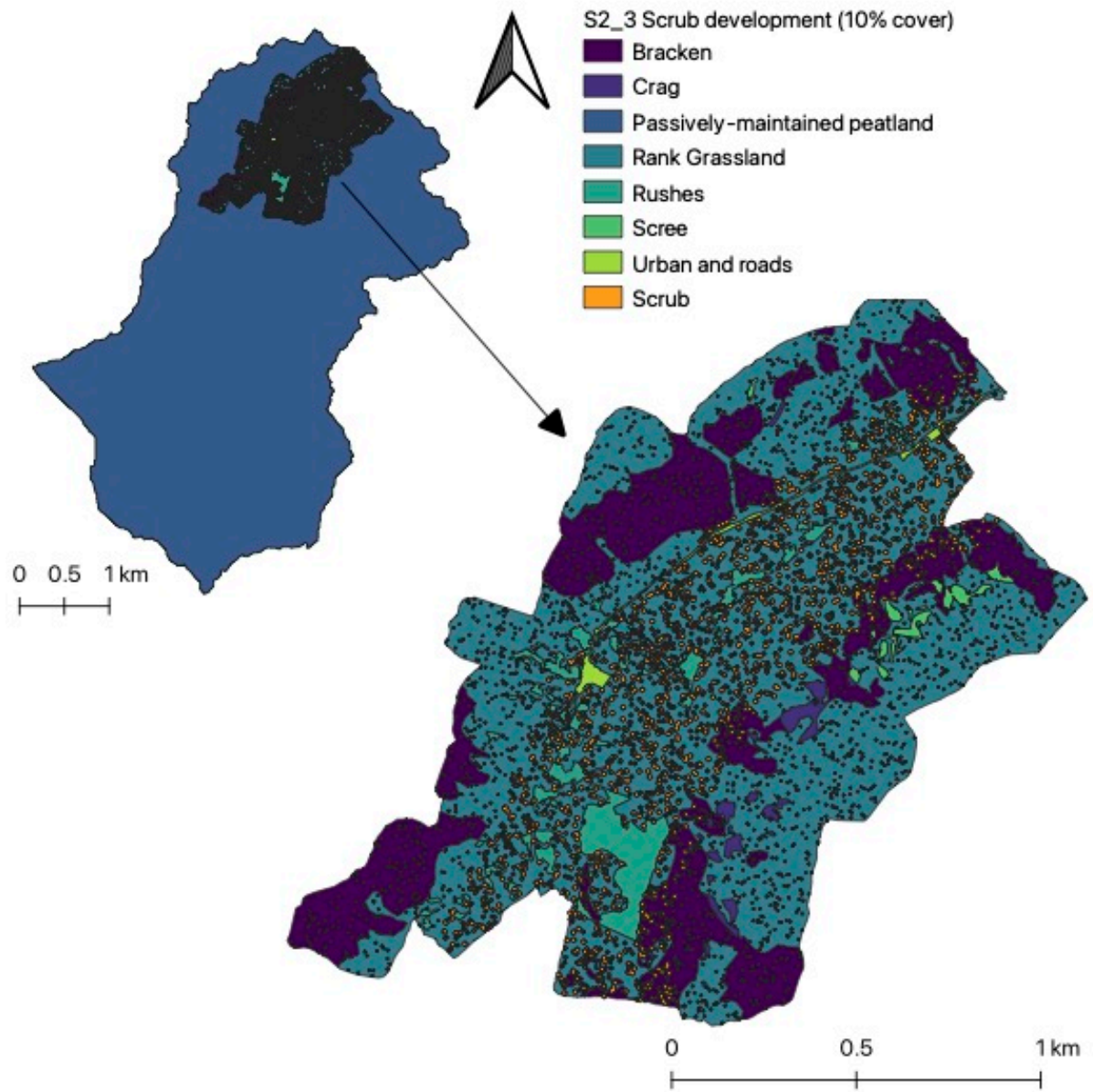

Figure C2.4: Map for Scenario S2\_3

Table C2.6: Parameters for management scenario S2\_3. Parameters are relative to the baseline value per land cover. Land covers differing from the baseline scenario are highlighted in blue.

S2_3: Catchment in 5-10 years' time if all management were removed. Scrub develops across 10% of the catchment								
Baseline land cover	New land cover	How has the land cover changed from the baseline?	Kv		K		I <sub>n</sub>	
			Velocity, m s <sup>-1</sup>	Relative velocity	Median K <sub>s</sub> , m hr <sup>-1</sup>	Relative K	I <sub>n</sub> (%)	Map value (1-%)
Mosedale	Passively maintained peatland	Same as baseline	0.0232	1.0000	1.8000	1.0000	0	1
Rosgill & Ralfland Common	Passively maintained peatland	Same as baseline	0.0232	1.0000	1.8000	1.0000	0	1
Mardale Common	Passively maintained peatland	Same as baseline	0.0232	1.0000	1.8000	1.0000	0	1
Urban & Roads	Urban & Roads	Same as baseline	0.0504	2.1726	0.0010	0.0006	0	1
Good Grazing	Rank Grassland	Convert to 'rank grassland' (annual)	0.0257	0.8893	0.0993	7.7365	0	1
Rough Grazing	Rank Grassland	Convert to 'rank grassland' (annual)	0.0257	0.9406	0.0993	2.1114	0	1
Bracken	Bracken	Same as baseline	0.0380	1.6393	0.4154	0.2308	0	1
Crag	Crag	Same as baseline	0.0504	2.1726	0.0010	0.0006	0	1
Hay Meadows	Rank Grassland	Convert to 'rank grassland' (annual)	0.0257	0.6288	0.0993	0.8688	0	1
Rank Grassland	Rank Grassland	Same as baseline	0.0257	1.1087	0.0993	0.0551	0	1
Rushes	Rushes	Same as baseline	0.0320	1.3805	0.0049	0.0027	0	1
Scree	Scree	Same as baseline	0.0504	2.1726	0.0010	0.0006	0	1
	Scrub	Random points 2-6m diameter, higher density below 305m elevation. Winter I <sub>n</sub> values (hawthorn)	0.043	1.3371	0.1647	1.1959	12	0.88

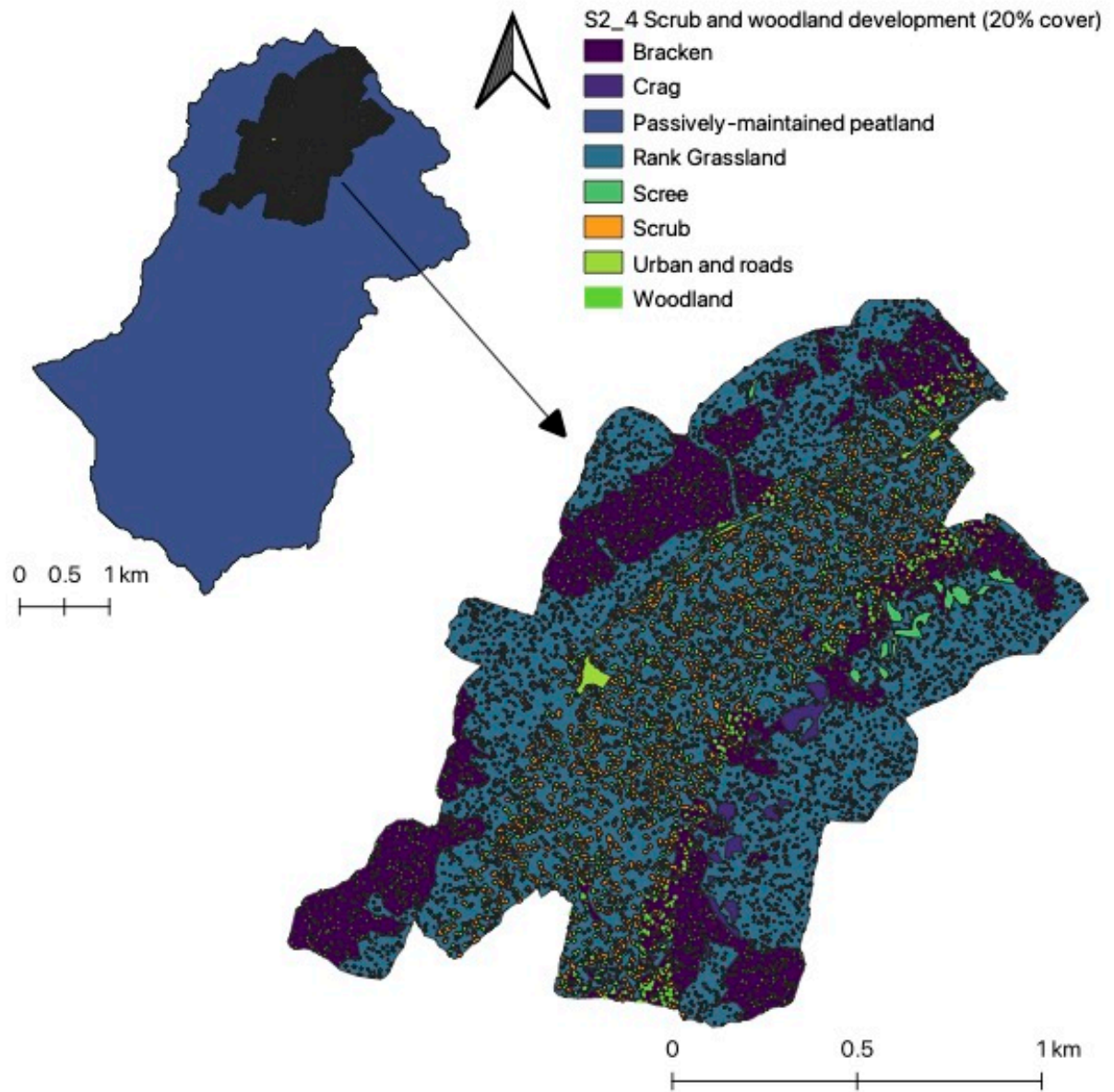

Figure C2.5: Map for Scenario S2\_4

Table C2.7: Parameters for management scenario S2\_4. Parameters are relative to the baseline value per land cover. Land covers differing from the baseline scenario are highlighted in blue.

<b>S2_4: Catchment in 10-50 years' time if all management were removed. Scrub and woodland develop across 20% of the catchment</b>								
Baseline land cover	New land cover	How has the land cover changed from the baseline?	Kv		K		I <sub>n</sub>	
			Velocity, m s <sup>-1</sup>	Relative velocity	Median K <sub>s</sub> , m hr <sup>-1</sup>	Relative K	I <sub>n</sub> (%)	Map value (1-%)
Mosedale	Passively maintained peatland	Same as baseline	0.0232	1.0000	1.8000	1.0000	0	1
Rosgill & Ralfland Common	Passively maintained peatland	Same as baseline	0.0232	1.0000	1.8000	1.0000	0	1
Mardale Common	Passively maintained peatland	Same as baseline	0.0232	1.0000	1.8000	1.0000	0	1
Urban & Roads	Urban & Roads	Same as baseline	0.0504	2.1726	0.0010	0.0006	0	1
Good Grazing	Rank Grassland	Convert to 'rank grassland' (annual)	0.0257	0.8893	0.0993	7.7365	0	1
Rough Grazing	Rank Grassland	Convert to 'rank grassland' (annual)	0.0257	0.9406	0.0993	2.1114	0	1
Bracken	Bracken	Same as baseline	0.0380	1.6393	0.4154	0.2308	0	1
Crag	Crag	Same as baseline	0.0504	2.1726	0.0010	0.0006	0	1
Hay Meadows	Rank Grassland	Convert to 'rank grassland' (annual)	0.0257	0.6288	0.0993	0.8688	0	1
Rank Grassland	Rank Grassland	Same as baseline	0.0257	1.1087	0.0993	0.0551	0	1
Rushes	Rushes	Same as baseline	0.0320	1.3805	0.0049	0.0027	0	1
Scree	Scree	Same as baseline	0.0504	2.1726	0.0010	0.0006	0	1
	Scrub	Random points 2-6m diameter, higher density below 305m elevation. Winter I <sub>n</sub> values (Hawthorn)	0.043	1.3382	0.1647	1.4248	12	0.88
	Woodland	Random points 2-6m diameter, higher density below 305m elevation. Winter I <sub>n</sub> values (mixed woodland)	0.043	1.3371	0.3711	2.6937	13	0.87



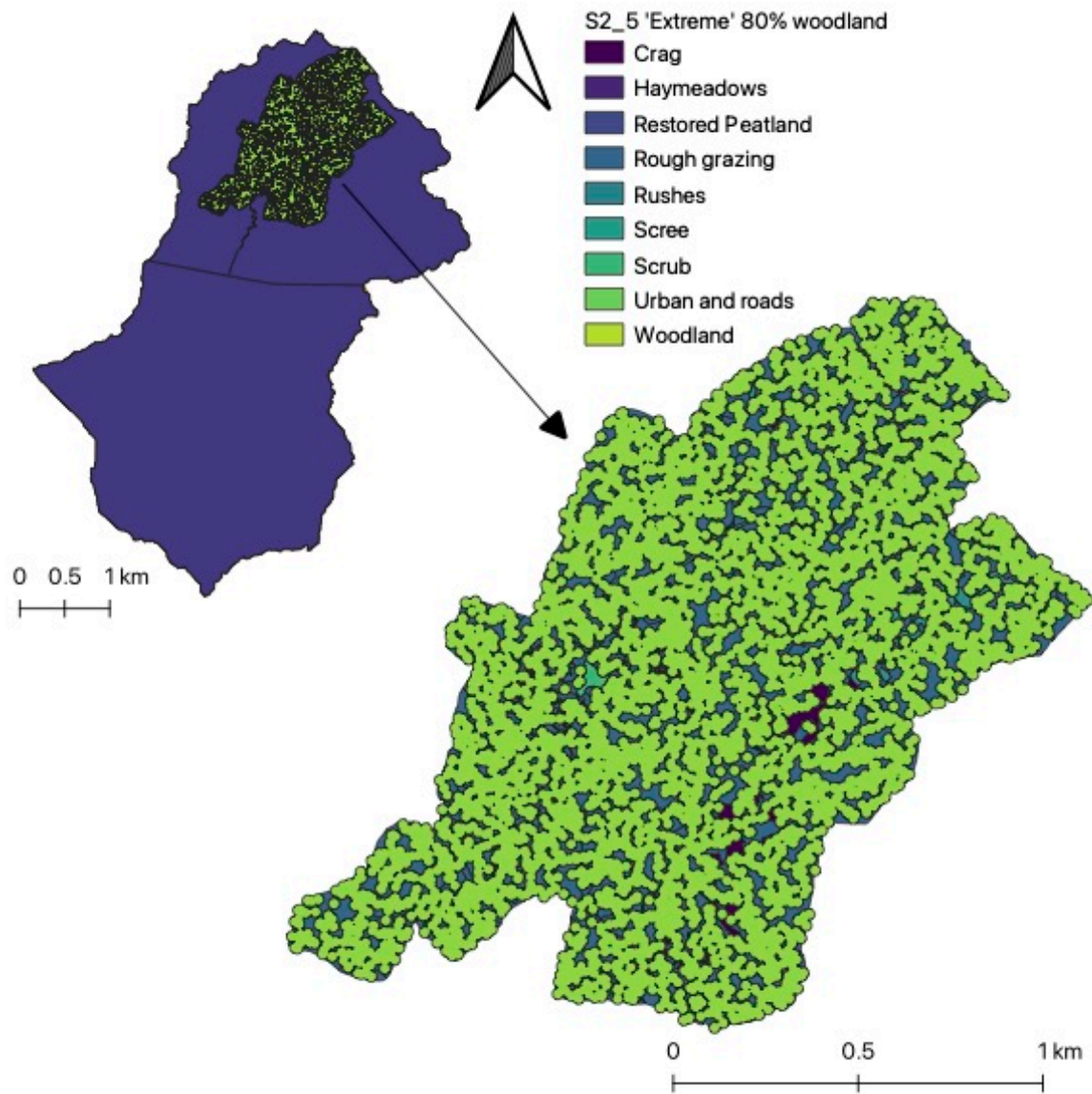

Figure C2.6: Map for Scenario S2\_5

Table C2.8: Parameters for management scenario S2\_5. Parameters are relative to the baseline value per land cover. Land covers differing from the baseline scenario are highlighted in blue.

S2_5: Extreme scenario. Catchment in 50+ years' time if all management were removed and woodland spread to cover 80% of the catchment.								
Baseline land cover	New land cover	How has the land cover changed from the baseline?	Kv		K		I <sub>n</sub>	
			Velocity, m s <sup>-1</sup>	Relative velocity	Median K <sub>s</sub> , m hr <sup>-1</sup>	Relative K	I <sub>n</sub> (%)	Map value (1-%)
Mosedale	Passively maintained peatland	Same as baseline	0.0232	1.0000	1.8000	1.0000	0	1
Rosgill & Ralfland Common	Passively maintained peatland	Same as baseline	0.0232	1.0000	1.8000	1.0000	0	1
Mardale Common	Passively maintained peatland	Same as baseline	0.0232	1.0000	1.8000	1.0000	0	1
Urban & Roads	Urban & Roads	Same as baseline	0.0504	2.1726	0.0010	0.0006	0	1
Good Grazing	Rank Grassland	Convert to 'rank grassland' (annual)	0.0257	0.8893	0.0993	7.7365	0	1
Rough Grazing	Rank Grassland	Convert to 'rank grassland' (annual)	0.0257	0.9406	0.0993	2.1114	0	1
Bracken	Rank Grassland	Convert to 'rank grassland' (annual)	0.0257	0.6763	0.0993	0.2390	0	1
Crag	Crag	Same as baseline	0.0504	2.1726	0.0010	0.0006	0	1
Hay Meadows	Rank Grassland	Convert to 'rank grassland' (annual)	0.0257	0.6288	0.0993	0.8688	0	1
Rank Grassland	Rank Grassland	Same as baseline	0.0257	1.1087	0.0993	0.0551	0	1
Rushes	Rank Grassland	Convert to 'rank grassland' (annual)	0.0257	0.8031	0.0993	20.0795	0	1
Scree	Scree	Same as baseline	0.0504	2.1726	0.0010	0.0006	0	1
	Woodland	Random points 15m diameter covering 80% of the catchment. Winter I <sub>n</sub> values (mixed woodland)	0.043	1.3382	0.3711	3.2094	13	0.87

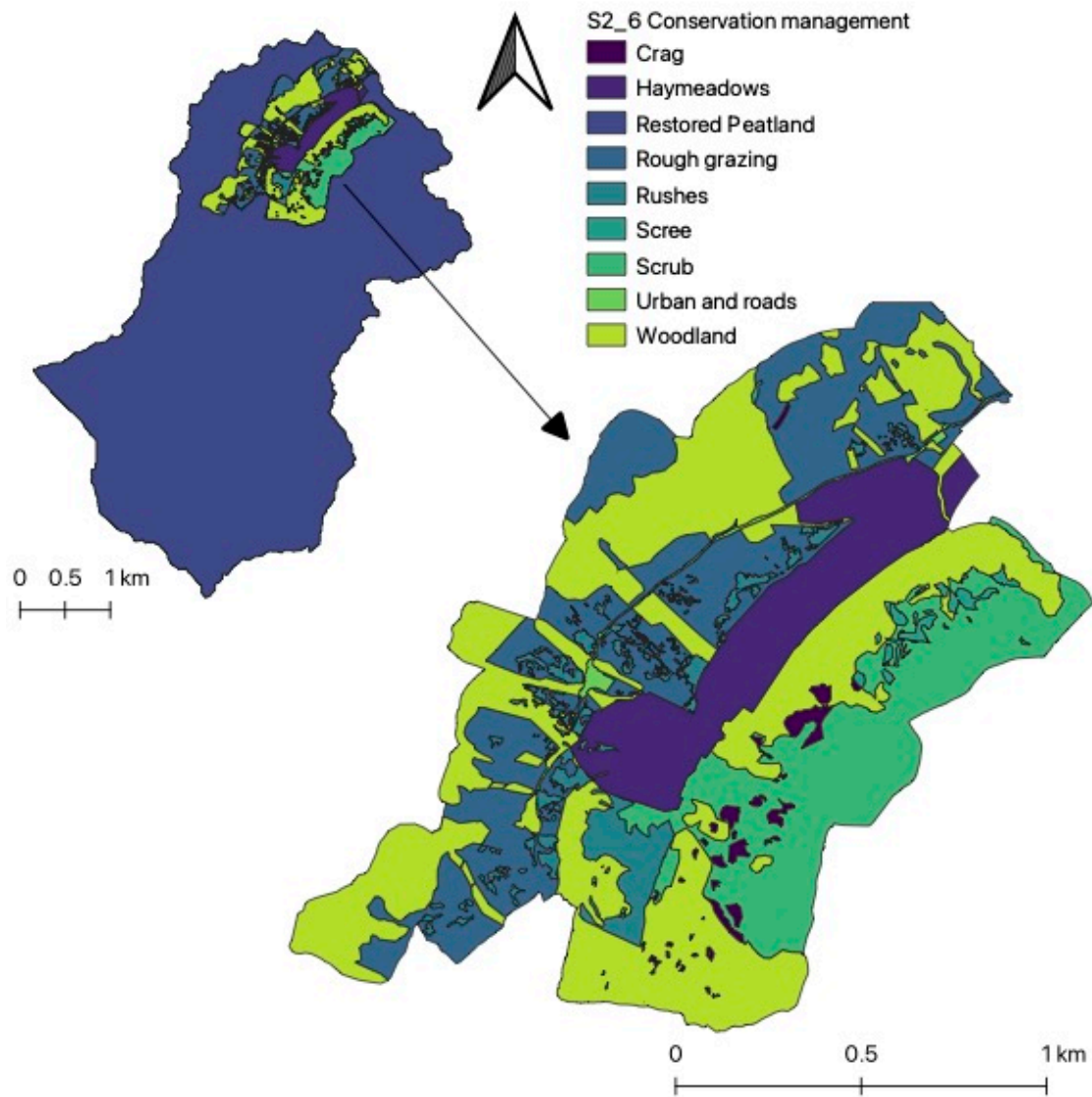

Figure C2.7: Map for Scenario S2\_6

Table C2.9: Parameters for management scenario S2\_6. Parameters are relative to the baseline value per land cover. Land covers differing from the baseline scenario are highlighted in blue.

<b>S2_6: Conservation management. Haymeadows are maintained for biodiversity, rank grassland and bracken are converted to woodland and scrub, low-density grazing is introduced.</b>								
Baseline land cover	New land cover	How has the land cover changed from the baseline?	<i>Kv</i>		<i>K</i>		<i>I<sub>n</sub></i>	
			Velocity, m s <sup>-1</sup>	Relative velocity	Median <i>K<sub>s</sub></i> , m hr <sup>-1</sup>	Relative <i>K</i>	<i>I<sub>n</sub></i> (%)	Map value (1-%)
Mosedale	Restored peatland	Same as baseline	0.0232	1.0000	1.8000	1.0000	0	1
Rosgill & Ralfland Common	Restored peatland	Same as baseline	0.0232	1.0000	1.8000	1.0000	0	1
Mardale Common	Restored peatland	Same as baseline	0.0232	1.0000	1.8000	1.0000	0	1
Urban & Roads	Urban & Roads	Same as baseline	0.0504	2.1726	0.0010	0.0006	0	1
Good Grazing	Rough Grazing	Assume Rough Grazing=Cattle Grazing	0.0273	0.9455	0.0470	3.6642	0	1
Rough Grazing	Rough Grazing	Assume Rough Grazing=Cattle Grazing	0.0273	1.1788	0.0470	0.0261	0	1
Bracken	Woodland	Replace Bracken with woodland	0.043	1.1316	0.3711	0.8933	13	0.87
Crag	Crag	Same as baseline	0.0504	2.1726	0.0010	0.0006	0	1
Hay Meadows	Hay Meadows	Same as baseline	0.0409	1.7632	0.1143	0.0635	0	1
Rank Grassland	Woodland	Replace most Rank Grassland with woodland	0.043	1.6732	0.3711	3.7382	13	0.87
Rushes	Rushes	Same as baseline	0.0320	1.3805	0.0049	0.0027	0	1
Scree	Scree	Same as baseline	0.0504	2.1726	0.0010	0.0006	0	1
Rank Grassland	Scrub	On steep/high elevation sites where woodland can't be planted (previous land cover rank grassland)	0.043	1.6732	0.1647	1.6596	12	0.88

## References

- Bond, S., Kirkby, M. J., & Holden, J. (2021). Upland grassland management influences organo-mineral soil properties and their hydrological function. *Ecohydrology*, e2336.
- Bond, S., Kirkby, M. J., Johnston, J., Crowle, A., & Holden, J. (2020). Seasonal vegetation and management influence overland flow velocity and roughness in upland grasslands. *Hydrological Processes*, 34(18), 3777-3791.
- Gao, J., Holden, J., & Kirkby, M. (2015). A distributed TOPMODEL for modelling impacts of land-cover change on river flow in upland peatland catchments. *Hydrological Processes*, 29(13), 2867-2879.
- Herbst, M., Roberts, J. M., Rosier, P. T., & Gowing, D. J. (2006). Measuring and modelling the rainfall interception loss by hedgerows in southern England. *Agricultural and Forest Meteorology*, 141(2-4), 244-256.
- Herbst, M., Rosier, P. T., McNeil, D. D., Harding, R. J., & Gowing, D. J. (2008). Seasonal variability of interception evaporation from the canopy of a mixed deciduous forest. *Agricultural and Forest Meteorology*, 148(11), 1655-1667.
- Holden, J., Kirkby, M. J., Lane, S. N., Milledge, D. G., Brookes, C. J., Holden, V., & McDonald, A. T. (2008). Overland flow velocity and roughness properties in peatlands. *Water Resources Research*, 44(6).
- Monger, F., Bond, S., Spracklen, D., & Kirkby, M. (2022). Overland flow velocity and soil properties in established semi-natural woodland and wood pasture in an upland catchment. *Hydrological Processes*, e14567.

### C.3 Calderdale land uses and model parameters

Appendix C3 describes the  $K_v$ ,  $K$  and  $m$  parameters for the seasonality (C1) and management (C2) scenarios in Calderdale. In the following paragraphs, abbreviations will be used to refer to individual land cover types within the Calderdale catchment. AG = Acid grassland, Bd = Buildings, Co = Concrete, DW = Drystone wall, H = Heather, HG = Heather grassland, IG = Improved grassland, PB = Peat Bog, RiG = Riparian grassland, WC = Woodland (coniferous), WM = Woodland (mixed), WR = Woodland (riparian, mixed).

When referring to Swindale land covers, abbreviations are also used, preceded by *SD*:

Abbreviations include: B = Bracken, C = Crag, GG = Good Grazing, HM = Hay Meadows, MC = Mardale Common, MD = Mosedale, RG = Rank Grassland, RRC = Rosgil and Ralfland Common, RoG = Rough Grazing, R = Rushes, S = Scree and UR = Urban and Roads. These abbreviations are the same as in Appendix C2.

For all model scenarios, the parameter file values were  $K = 6.109248$ ,  $K_v = 12$ ,  $m = 0.008$ .

#### Baseline

The current (baseline) land cover for Calderdale is shown in Figure C3.1. This land cover is the baseline catchment layout against which all scenarios are compared. Baseline model parameters, their Swindale equivalent and any new sources are given as part of Table C3.1 and Table C3.2.

#### **$K_v$ , surface roughness**

Roughness values for Calderdale were derived from field data collected by Bond et al. (2020), Holden et al. (2008) and Monger et al. (2022). A breakdown of land covers represented by each source is given in Table 4.4 of the main text.

Velocity measurements from each field source were used to determine the relative difference between land covers to input into spatially-distributed maps. For the baseline map, the annual average value was used and the difference between land covers was calculated relative to Acid grassland. Since  $K_v$  and  $V$  are directly proportional, this was

considered a reasonable substitute. All literature sources used the same applied flow rate of  $12 \text{ L min}^{-1}$  to measure overland flow velocity. Through calibration, a final parameter file value of 12 was chosen as a best-fit  $K_v$ .

### **$K$ , the permeability**

$K$  values were also derived from literature and the sources per land cover are given in Table 4 of the main text. A parameter file value of  $K = 6.109248$  ( $K_s = 450 \text{ m h}^{-1}$ ) was derived through model calibration. The parameter file value represents a scaling factor. Gao et al. (2015) recommend for peat soils a model  $K_s$  value of  $100\text{-}300 \text{ m h}^{-1}$ . Since much of Calderdale is underlain by blanket peat or highly permeable, shallow, organo-mineral soils with shale underneath (Bond et al., 2021), a value of  $K_s = 450 \text{ m h}^{-1}$  was considered acceptable. Relative  $K_s$  was calculated between land covers to form the  $K$  parameter map where all values were relative to Acid grassland (Table C3.2).

### **$m$ , the active storage**

$m = 0.008$  was calculated through calibration and was used as a lumped parameter in all Calderdale scenarios. In all scenarios, the parameter file value was 0.008 and the  $m$  map value was 1.

### **Interception**

Interception ( $I_n$ ) parameter values were applied in map format only. Annual average values were used for the seasonality scenarios and winter values for the Management scenarios. Parameter sources per land cover are given in Table 4.4 of the main text

- Calderdale current (base) land cover
- Acid grassland
  - Bog
  - Building
  - Concrete
  - Heather
  - Heather grassland
  - Improved grassland
  - Riparian
  - Wall
  - Woodland (coniferous)
  - Woodland (mixed)
  - Woodland (riparian mixed)

Elevation: 124.4 - 478.5 m

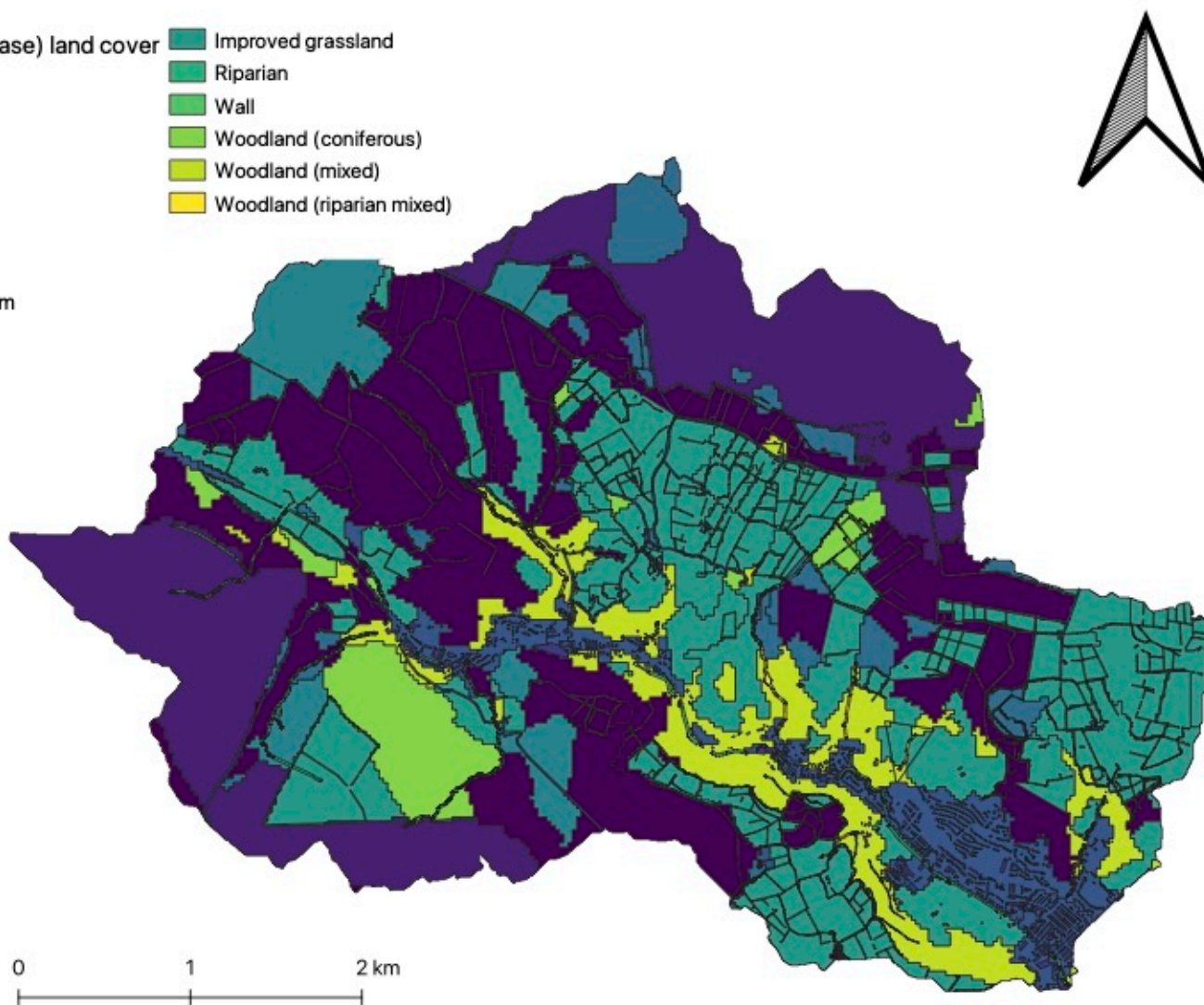

Figure C3.1: Baseline land cover for Calderdale



Table C3.1:  $K_v$  and  $K$  values for the Calderdale baseline map (current land cover). SD-TOPMODEL was calibrated maintaining the relative differences between land covers.

Land cover	$K_v$ , Roughness			$K$ , Hydraulic Conductivity		
	Parameter file value, $K_v = 12$			Parameter file value = $6.109248$ ( $K_s = 450 \text{ m h}^{-1}$ )		
	Source/Swindale (SD) equivalent land cover	Annual velocity	Relative velocity	Source/Swindale equivalent land cover	Median $K_s$ (m/hour)	Relative $K_s$
Acid grassland	SD: Rough Grazing	0.0273	1.0000	SD: Mosedale	1.8000	1.0000
Bog	SD: Mosedale	0.0232	0.8483	SD: Mosedale	1.8000	1.0000
Building	SD: Urban & Roads	0.0504	1.8431	SD: Urban & Roads	0.0010	0.0006
Concrete	SD: Urban & Roads	0.0504	1.8431	SD: Urban & Roads	0.0010	0.0006
Heather	Monger et al. (2022)	0.0430	1.5737	Kingsbury-Smith (2019)	0.1647	0.0915
Heather grassland	Average between Woodland (Monger et al., 2022) and SD: Rough Grazing. Assume less rough than total scrub cover	0.0352	1.2868	Average between Hedgerow (Kingsbury-Smith, 2019) and SD: Rough Grazing.	0.1059	0.0588
Improved grassland	SD: Good Grazing	0.0289	1.0577	SD: Good Grazing	0.0128	0.0071
Riparian	SD: Rank grassland	0.0257	0.9406	SD: Rank grassland	0.0993	0.0551
Wall	SD: Urban & Roads	0.0504	1.8431	SD: Urban & Roads	0.0010	0.0006
Woodland - coniferous	Woodland (Monger et al., In 2022)	0.0430	1.5737	Woodland (Kingsbury-Smith, 2019)	0.3711	0.2061
Woodland - mixed		0.0430	1.5737		0.3711	0.2061
Woodland - Riparian		0.0430	1.5737		0.3711	0.2061

Table C3.2:  $I_n$  and  $m$  values for the Calderdale baseline map (current land cover). Parameter values for mixed woodland were taken from Herbst et al. (2008). Values for Spruce were taken from Gash et al. (1980) and values for hedgerows were taken from Herbst et al. (2006).

Land cover	$m$ , Active Storage	Interception - Baseline for C1 (annual average)			Interception - Baseline for C2 (Winter values)		
	Parameter file value = 0.008 m	Source	$I_n$ %	Map value	Source	$I_n$ %	Map value
Acid grassland	1	NA	0	1	NA	0	1
Bog		NA	0	1	NA	0	1
Building		NA	0	1	NA	0	1
Concrete		NA	0	1	NA	0	1
Heather		Hedgerow	15.5	0.845	Hedgerow	12	0.88
Heather grassland		Halfway between grassland (0% $I_n$ ) and hedgerow	7.75	0.9225	Halfway between grassland (0% $I_n$ ) and hedgerow	6	0.94
Improved grassland		NA	0	1	NA	0	1
Riparian		NA	0	1	NA	0	1
Wall		NA	0	1	NA	0	1
Woodland - coniferous		Spruce	21	0.79	Spruce	21	0.79
Woodland - mixed		Mixed woodland	18.5	0.815	Mixed woodland	13	0.87
Woodland - Riparian		Mixed woodland	18.5	0.815	Mixed woodland	13	0.87

## **Scenario one: seasonality**

To represent season in Calderdale, only  $K_v$  and  $I_n$  were changed per scenario (April to November), maintaining baseline  $K$ ,  $m$  and catchment configuration (Table C3.1, Table C3.2). The relative-velocity map values and  $K_v$  parameter file value are shown in Table C3.3 and Table C3.4. For all model scenarios, the parameter file values were  $K = 6.109248$ ,  $K_v = 12$ ,  $m = 0.008$ .

### **$K_v$ , surface roughness**

Under the assumption of 'equivalent' land covers between Swindale and Calderdale (Table C3.1), seasonal data were available for the IG and RiG land covers, and seasonality could be estimated for HG as an average between SD:RG and WM, and AG as an average of SD: RG and SD: GG (Bond et al., 2020). Since seasonal roughness data was not available from Holden et al., (2008) or Monger et al., (2022), it was assumed that velocities recorded were equivalent to annual average values. To test the seasonal influence of  $K_v$  on flood peak and timing, seasonal change in velocity had to be estimated for land covers without such data. To do this, the comparative change in velocity per month for each Bond et al. (2020) land cover was calculated relative to its annual average velocity. The mean monthly relative value was then used as the baseline relative difference for the land covers without seasonal values. Using this baseline, seasonal velocity could be estimated for WM, WR and HG land covers. It was assumed that there was no seasonal change in  $K_v$  for PB, Bd, Co, H, DW or WC land covers. This is the same method and includes the same values as applied in Swindale.

After annual and seasonal velocity was determined, relative differences between land covers were calculated. For the annual average, difference between land covers was calculated relative to Mosedale, the largest land cover by area. When applying seasonal values, difference between land covers was calculated relative to each land cover's annual average velocity. The relative values were used to create spatially-distributed map files for SD-TOPMODEL using the current catchment land cover configuration.

### **Interception**

Although monthly  $I_n$  values were not available, changes in  $I_n$  were approximated from 'summer' and 'winter' values. Summer values were applied to June, July and September, while winter values were applied to April and November; these designations were based on Bond et al., (2020) who applied the same winter and summer comparisons.

Table C3.3: Kv Parameter value and relative velocity values for each land cover in Calderdale. Data from Holden et al. (2008) for 'Eriophorum-Sphagnum mix' was used for Acid grassland and bog, and 'bare peat' was used for Building, Concrete and Drystone wall. Data from Bond et al. (2020) was used for Improved grassland and Riparian. Woodland and Heather parameters were taken from Monger et al. (2022) and an estimate for Heather grassland velocity was calculated midway between Rough Grazing velocity measured in Swindale and the value given to Heather.

Land cover	Kv, Roughness											
	Parameter file value, Kv = 12											
	Annual average (C1 baseline)		April		June		July		Sept		Nov	
	Measured velocity, m s <sup>-1</sup>	Relative value (to Acid grassland)	Velocity, m s <sup>-1</sup>	Relative value (to annual)	Velocity, m s <sup>-1</sup>	Relative value (to annual)	Velocity, m s <sup>-1</sup>	Relative value (to annual)	Velocity, m s <sup>-1</sup>	Relative value (to annual)	Velocity, m s <sup>-1</sup>	Relative value (to annual)
Acid grassland	0.0273	1.0000	0.0305	1.1149	0.0306	1.1201	0.0259	0.9494	0.0250	0.9134	0.0287	1.0486
Bog	0.0232	0.8483	0.0269	1.1589	0.0234	1.0108	0.0212	0.9140	0.0219	0.9438	0.0262	1.1293
Building	0.0504	1.8431	0.0504	1.8431	0.0504	1.8431	0.0504	1.8431	0.0504	1.8431	0.0504	1.8431
Concrete	0.0504	1.8431	0.0504	1.8431	0.0504	1.8431	0.0504	1.8431	0.0504	1.8431	0.0504	1.8431
Heather	0.0430	1.5737	0.0430	1.5737	0.0430	1.5737	0.0430	1.5737	0.0430	1.5737	0.0430	1.5737
Heather grassland	0.0352	1.2868	0.0407	1.3443	0.0355	1.3469	0.0321	1.2616	0.0332	1.2435	0.0397	1.3111
Improved grassland	0.0289	1.0577	0.0301	1.0398	0.0315	1.0897	0.0319	1.1049	0.0234	0.8082	0.0278	0.9625
Riparian	0.0257	0.9406	0.0309	1.2015	0.297	1.1564	0.0200	0.7764	0.0266	1.0334	0.0295	1.1474
Wall (drystone)	0.0504	1.8431	0.0504	1.8431	0.0504	1.8431	0.0504	1.8431	0.0504	1.8431	0.0504	1.8431
Woodland (coniferous)	0.0430	1.5737	0.0430	1.5737	0.0430	1.5737	0.0430	1.5737	0.0430	1.5737	0.0430	1.5737
Woodland (mixed)	0.0430	1.5737	0.0498	1.1589	0.0435	1.0108	0.0393	0.9140	0.0406	0.9438	0.0486	1.1293
Woodland (riparian, mixed)	0.0430	1.5737	0.0498	1.1589	0.0435	1.0108	0.0393	0.9140	0.0406	0.9438	0.0486	1.1293

Table C3.4: Seasonal  $I_n$  values and their corresponding map values for Seasonality scenarios in Calderdale. Parameter values for mixed woodland were taken from Herbst et al. (2008). Values for Spruce were taken from Gash et al. (1980) and values for hedgerows were taken from Herbst et al. (2006).

Land cover	Interception											
	Annual average (C1 baseline)		April		June		July		Sept		Nov	
	$I_n$ (%)	Map value for SD-TOPMODEL	$I_n$ (%)	Map value for SD-TOPMODEL	$I_n$ (%)	Map value for SD-TOPMODEL	$I_n$ (%)	Map value for SD-TOPMODEL	$I_n$ (%)	Map value for SD-TOPMODEL	$I_n$ (%)	Map value for SD-TOPMODEL
Acid grassland	0	1	0	1	0	1	0	1	0	1	0	1
Bog	0	1	0	1	0	1	0	1	0	1	0	1
Building	0	1	0	1	0	1	0	1	0	1	0	1
Concrete	0	1	0	1	0	1	0	1	0	1	0	1
Heather	15.5	0.845	12	0.88	19	0.81	19	0.81	19	0.81	12	0.88
Heather grassland	7.75	0.9225	6	0.94	9.5	0.905	9.5	0.905	9.5	0.905	6	0.94
Improved grassland	0	1	0	1	0	1	0	1	0	1	0	1
Riparian	0	1	0	1	0	1	0	1	0	1	0	1
Wall (drystone)	0	1	0	1	0	1	0	1	0	1	0	1
Woodland (coniferous)	21	0.79	21	0.79	21	0.79	21	0.79	21	0.79	21	0.79
Woodland (mixed)	18.5	0.815	13	0.87	24	0.76	24	0.76	24	0.76	13	0.87
Woodland (riparian, mixed)	18.5	0.815	13	0.87	24	0.76	24	0.76	24	0.76	13	0.87

## Scenario two: management

Management scenarios for Calderdale were the same as those in Swindale (Appendix C2), and map parameter values were applied based on equivalent Swindale land covers or new literature sources (Table C3.1). Although scenarios chosen were the same, the catchment configuration and percentage cover of each land cover was different from those in Swindale due to the configuration of baseline grassland (where management was applied to baseline grassland areas only in both catchments). An exception to this was scenario 2\_1 for which Swindale management change also incorporated surrounding commons land. Therefore, an additional management scenario, 2\_1a, was applied in Calderdale based on the Swindale historical grazing land cover, allowing for direct comparison between catchments.

Maps of each scenario are given in Figure C3.2 to Figure C3.8. The parameters applied to each spatially distributed scenario map are given in Table C3.5 to Table C3.11. As with scenario S1 above, all models are designed to be compared with the baseline model (Figure C2.1).

For all model scenarios, the parameter file values were  $K = 6.109248$ ,  $Kv = 12$ ,  $m = 0.008$ .

- C2\_1 Intensive grazing
- Acid grassland
  - Bog
  - Building
  - Concrete
  - Heather
  - Heather grassland
  - Wall
  - Woodland (coniferous)
  - Woodland (mixed)
  - Woodland (riparian)
  - Heavily compacted (new)
  - Intensive grazing (new)

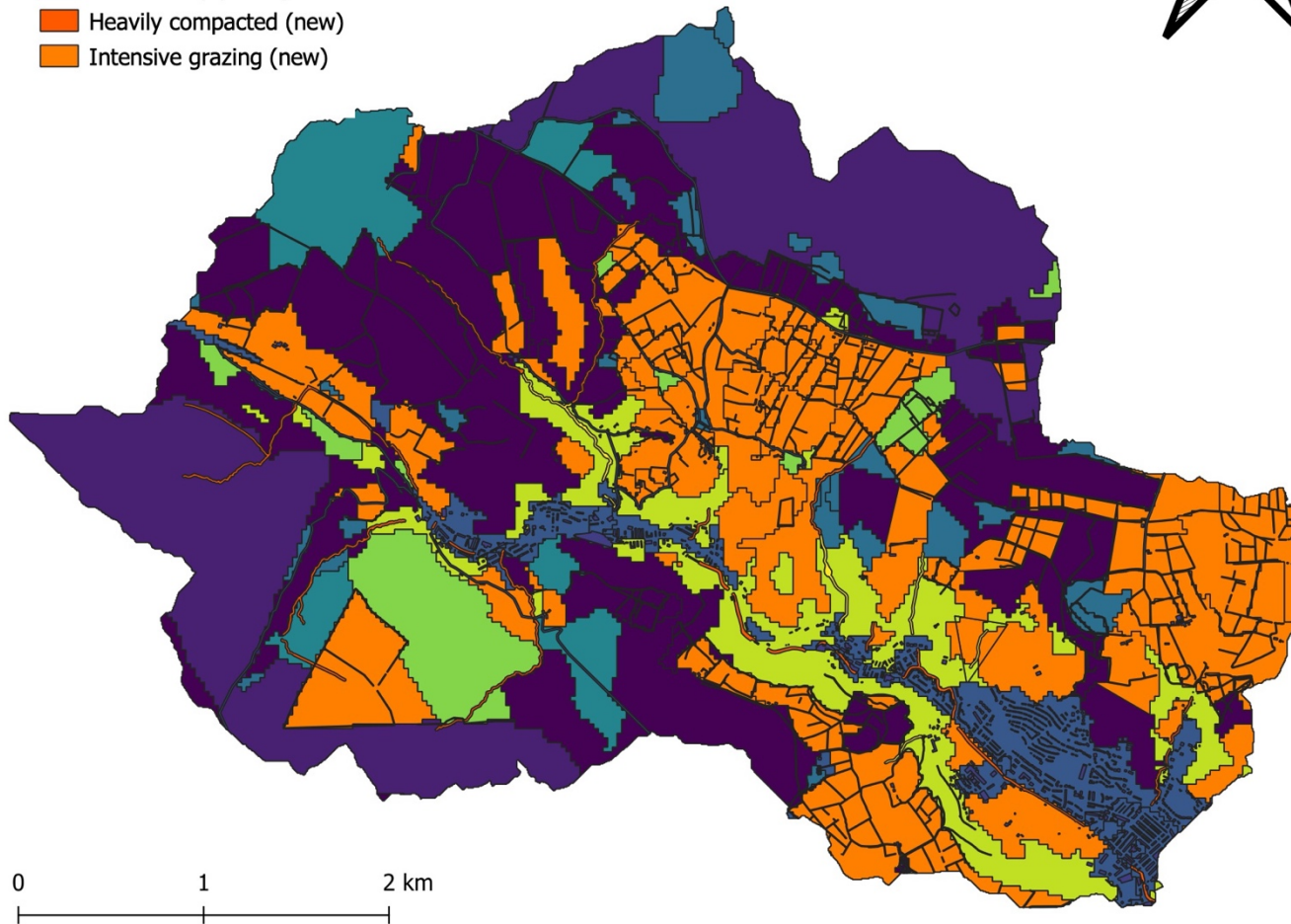

Figure C3.2: Map for Scenario C2\_1



Table C3.5: Parameters for re-wilding scenario C2\_1. Parameters are relative to the baseline value per land cover. Land covers differing from the baseline scenario are highlighted in blue.

C2_1: High intensity grazing								
Baseline land cover	New land cover	How has the land cover changed from the baseline?	Kv		K		I <sub>n</sub>	
			Velocity, m s <sup>-1</sup>	Relative velocity	Median K <sub>s</sub> , m hr <sup>-1</sup>	Relative K	I <sub>n</sub> (%)	Map value (1-%)
Acid grassland	Acid grassland	Same as baseline	0.0273	1.0000	1.8000	1.0000	0	1
Bog	Bog	Same as baseline	0.0232	1.0000	1.8000	1.0000	0	1
Building	Building	Same as baseline	0.0504	1.0000	0.0010	1.0000	0	1
Concrete	Concrete	Same as baseline	0.0504	1.0000	0.0010	1.0000	0	1
Heather	Heather	Same as baseline	0.0430	1.0000	0.1647	1.0000	12	0.88
Heather grassland	Heather grassland	Same as baseline	0.0352	1.0000	0.1059	1.0000	6	0.94
Improved grassland	Intensive grazing	Kv is SD: Haymeadows roughness after cutting and with grazing (Nov).	0.0522	1.8058	0.0128	0.0071	0	1
Riparian	Heavily compacted	K is SD: Haymeadows annual	0.0522	2.0307	0.0128	0.1293	0	1
Wall	Wall	Same as baseline	0.0504	1.0000	0.0010	1.0000	0	1
Woodland (coniferous)	Woodland (coniferous)	Same as baseline	0.0430	1.0000	0.3711	1.0000	21	0.79
Woodland (mixed)	Woodland (mixed)	Same as baseline	0.0430	1.0000	0.3711	1.0000	13	0.87
Woodland (riparian, mixed)	Woodland (riparian, mixed)	Same as baseline	0.0430	1.0000	0.3711	1.0000	13	0.87

- C2\_1a (Like Swindale) intensive grazing
- Bog
  - Building
  - Concrete
  - Wall
  - Heavily compacted (new)
  - Intensive grazing (new)
  - Medium grazing (new)
  - Rough grazing (new)

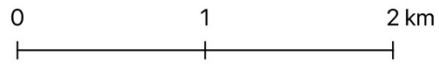
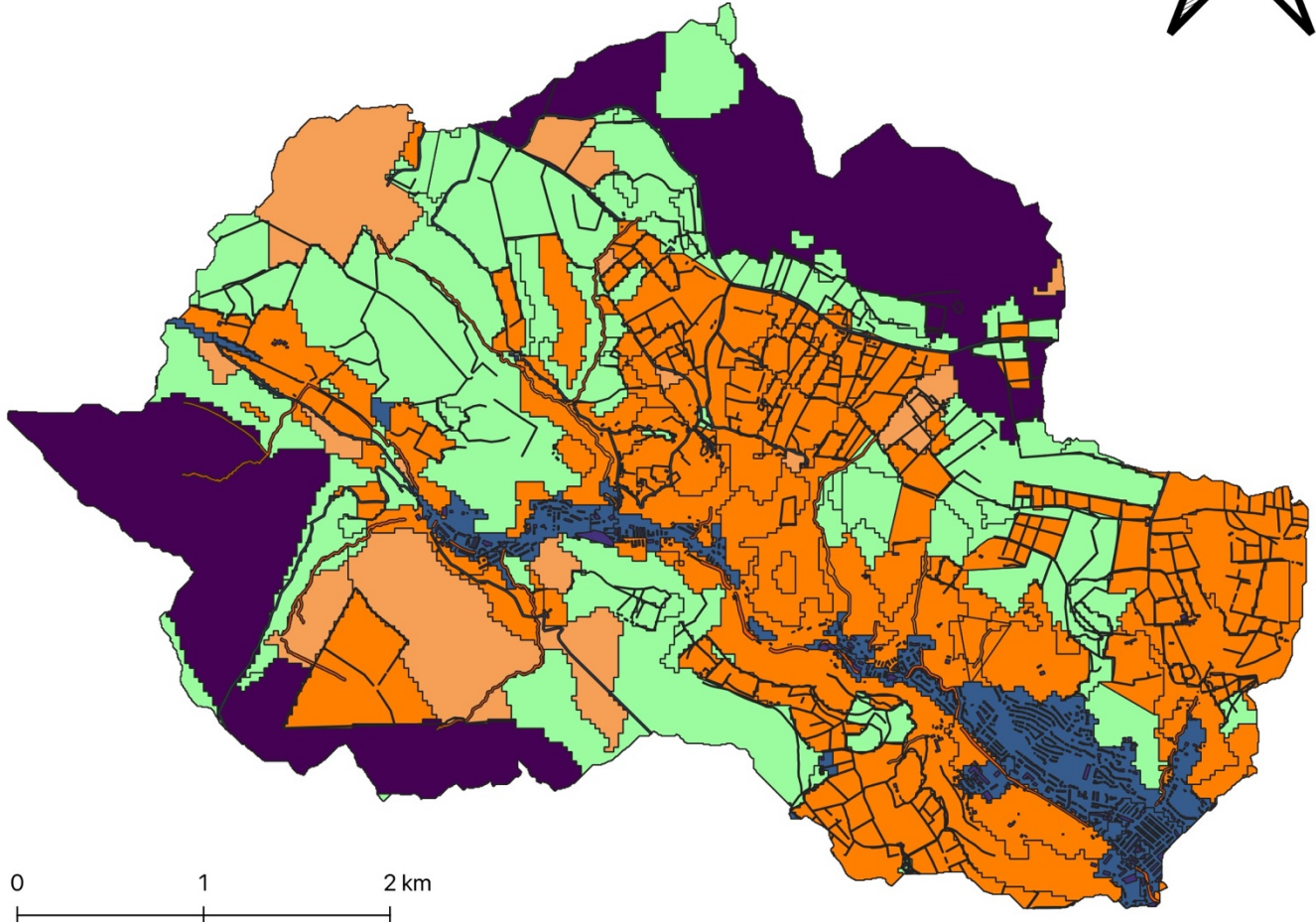
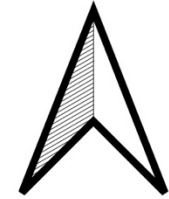

Figure C3.3: Map for Scenario C2\_1a

Table C3.6: Parameters for re-wilding scenario C2\_1a. Parameters are relative to the baseline value per land cover. Land covers differing from the baseline scenario are highlighted in blue.

C2_1a: Revert to high intensity grazing similarly to Swindale								
Baseline land cover	New land cover	How has the land cover changed from the baseline?	K <sub>v</sub>		K		I <sub>n</sub>	
			Velocity, m s <sup>-1</sup>	Relative velocity	Median K <sub>s</sub> , m hr <sup>-1</sup>	Relative K	I <sub>n</sub> (%)	Map value (1-%)
Acid grassland	Rough Grazing	Same as SD: Rough Grazing annual	0.0273	1.0000	0.0470	0.0261	0	1
Bog	Same as baseline	Same as baseline	0.0232	1.0000	1.8000	1.0000	0	1
Building	Same as baseline	Same as baseline	0.0504	1.0000	0.0010	1.0000	0	1
Concrete	Same as baseline	Same as baseline	0.0504	1.0000	0.0010	1.0000	0	1
Heather	Rough Grazing	Same as baseline	0.0273	0.6354	0.0470	0.2854	0	1
Heather grassland	Medium grazing	K <sub>v</sub> is SD: Good Grazing July. K is SD: Good Grazing annual	0.0319	0.9081	0.0128	0.1212	0	1
Improved grassland	Intensive grazing	K <sub>v</sub> is SD: Haymeadows roughness after cutting and with grazing (Nov).	0.0522	1.8058	0.0128	0.0071	0	1
Riparian	Heavily compacted	K is SD: Haymeadows annual	0.0522	2.0307	0.0128	0.1293	0	1
Wall	Same as baseline		0.0504	1.0000	0.0010	1.0000	0	1
Woodland (coniferous)	Medium grazing	K <sub>v</sub> is SD: Good Grazing July. K is SD: Good Grazing annual	0.0319	0.7426	0.0128	0.0346	0	1
Woodland (mixed)	Intensive grazing	K <sub>v</sub> is SD: Haymeadows roughness after cutting and with grazing (Nov).	0.0522	1.2137	0.0128	0.0346	0	1
Woodland (riparian, mixed)	Intensive grazing	K is SD: Haymeadows annual	0.0522	1.2137	0.0128	0.0346	0	1

C2\_2 Management removed

- Acid grassland
- Bog
- Building
- Concrete
- Heather

- Heather grassland
- Wall
- Woodland (coniferous)
- Woodland (mixed)
- Woodland (riparian)
- Rank grassland (new)

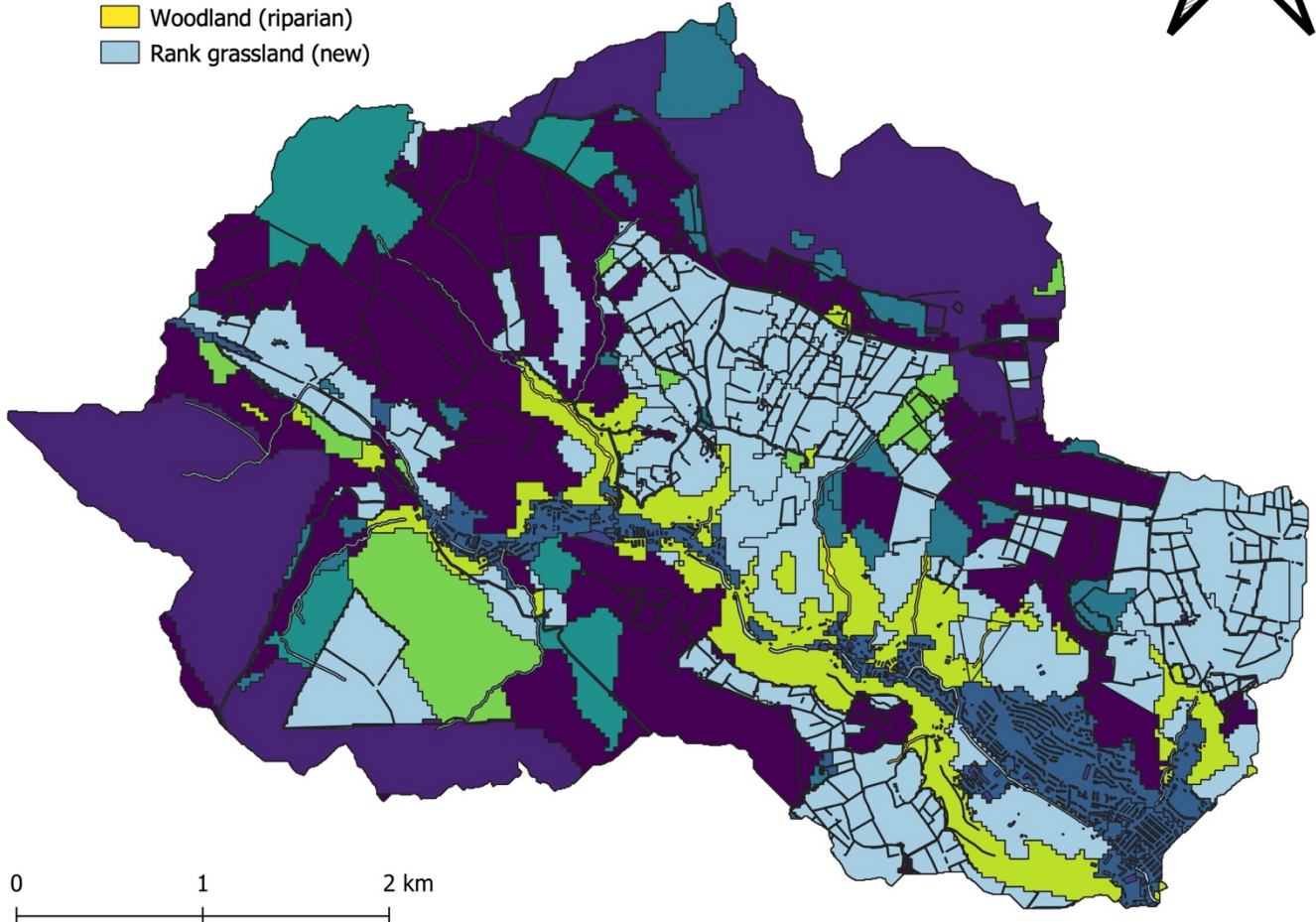

0 1 2 km

Figure C3.4: Map for Scenario C2\_2

Table C3.7: Parameters for re-wilding scenario C2\_2. Parameters are relative to the baseline value per land cover. Land covers differing from the baseline scenario are highlighted in blue.

<b>C2_2: Management: Catchment in approximately 2 years' time if all management were removed</b>								
Baseline land cover	New land cover	How has the land cover changed from the baseline?	Kv		K		I <sub>n</sub>	
			Velocity, m s <sup>-1</sup>	Relative velocity	Median K <sub>s</sub> , m hr <sup>-1</sup>	Relative K	I <sub>n</sub> (%)	Map value (1-%)
Acid grassland	Acid grassland	Same as baseline	0.0273	1.0000	1.8000	1.0000	0	1
Bog	Bog	Same as baseline	0.0232	1.0000	1.8000	1.0000	0	1
Building	Building	Same as baseline	0.0504	1.0000	0.0010	1.0000	0	1
Concrete	Concrete	Same as baseline	0.0504	1.0000	0.0010	1.0000	0	1
Heather	Heather	Same as baseline	0.0430	1.0000	0.1647	1.0000	12	0.88
Heather grassland	Heather grassland	Same as baseline	0.0352	1.0000	0.1059	1.0000	6	0.94
Improved grassland	Intensive grazing	Same as SD:Rank grassland annual	0.0257	0.8893	0.0993	7.7365	0	1
Riparian	Heavily compacted	Same as SD:Rank grassland annual	0.0257	1.0000	0.0993	1.0000	0	1
Wall	Wall	Same as baseline	0.0504	1.0000	0.0010	1.0000	0	1
Woodland (coniferous)	Woodland (coniferous)	Same as baseline	0.0430	1.0000	0.3711	1.0000	21	0.79
Woodland (mixed)	Woodland (mixed)	Same as baseline	0.0430	1.0000	0.3711	1.0000	13	0.87
Woodland (riparian, mixed)	Woodland (riparian, mixed)	Same as baseline	0.0430	1.0000	0.3711	1.0000	13	0.87

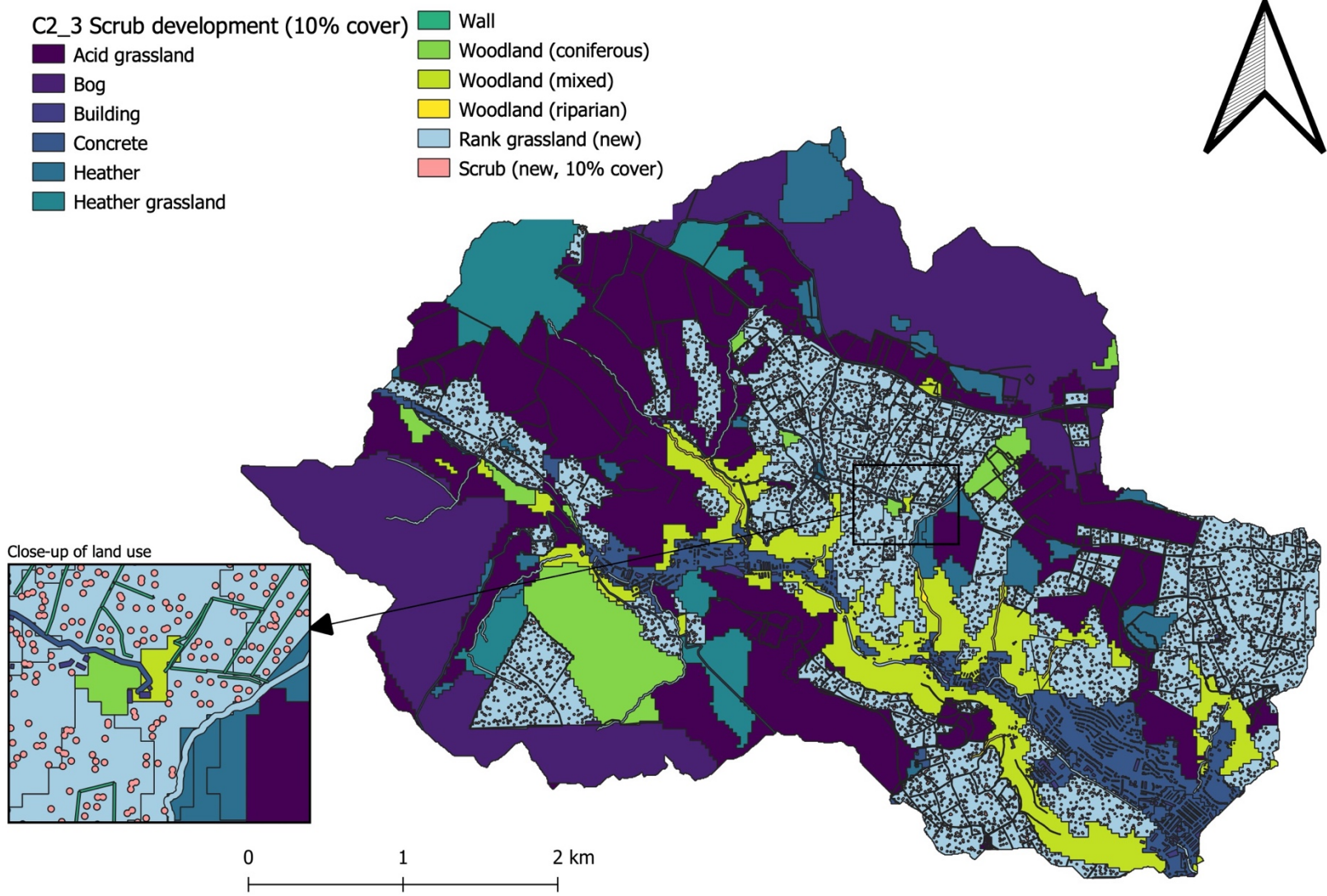

Figure C3.5: Map for Scenario C2\_3

Table C3.8: Parameters for re-wilding scenario C2\_3. Parameters are relative to the baseline value per land cover. Land covers differing from the baseline scenario are highlighted in blue.

<b>C2_3: Management: Catchment in 5-10 years' time if all management were removed. Scrub develops across 10% of the catchment</b>								
Baseline land cover	New land cover	How has the land cover changed from the baseline?	Kv		K		I <sub>n</sub>	
			Velocity, m s <sup>-1</sup>	Relative velocity	Median K <sub>s</sub> , m hr <sup>-1</sup>	Relative K	I <sub>n</sub> (%)	Map value (1-%)
Acid grassland	Acid grassland	Same as baseline	0.0273	1.0000	1.8000	1.0000	0	1
Bog	Bog	Same as baseline	0.0232	1.0000	1.8000	1.0000	0	1
Building	Building	Same as baseline	0.0504	1.0000	0.0010	1.0000	0	1
Concrete	Concrete	Same as baseline	0.0504	1.0000	0.0010	1.0000	0	1
Heather	Heather	Same as baseline	0.0430	1.0000	0.1647	1.0000	12	0.88
Heather grassland	Heather grassland	Same as baseline	0.0352	1.0000	0.1059	1.0000	6	0.94
Improved grassland	Intensive grazing	Same as SD:Rank grassland annual	0.0257	0.8893	0.0993	7.7365	0	1
Riparian	Heavily compacted	Same as SD:Rank grassland annual	0.0257	1.0000	0.0993	1.0000	0	1
Wall	Wall	Same as baseline	0.0504	1.0000	0.0010	1.0000	0	1
Woodland (coniferous)	Woodland (coniferous)	Same as baseline	0.0430	1.0000	0.3711	1.0000	21	0.79
Woodland (mixed)	Woodland (mixed)	Same as baseline	0.0430	1.0000	0.3711	1.0000	13	0.87
Woodland (riparian, mixed)	Woodland (riparian, mixed)	Same as baseline	0.0430	1.0000	0.3711	1.0000	13	0.87
Improved grassland and riparian	Scrub	Random points 6.25m diameter. Kv is Woodland and K is Heather. Winter I <sub>n</sub> values (Hedgerow Hawthorn).	0.043	1.6732	0.1647	1.6589	12	0.88

C2\_4 Scrub and woodland development (20% cover)

- Acid grassland
- Bog
- Building
- Concrete
- Heather
- Heather grassland
- Wall
- Woodland (coniferous)
- Woodland (mixed)
- Woodland (riparian, mixed)
- Rank grassland (new)
- Scrub (new, 10% cover)
- Woodland (new, 10% cover, mixed)

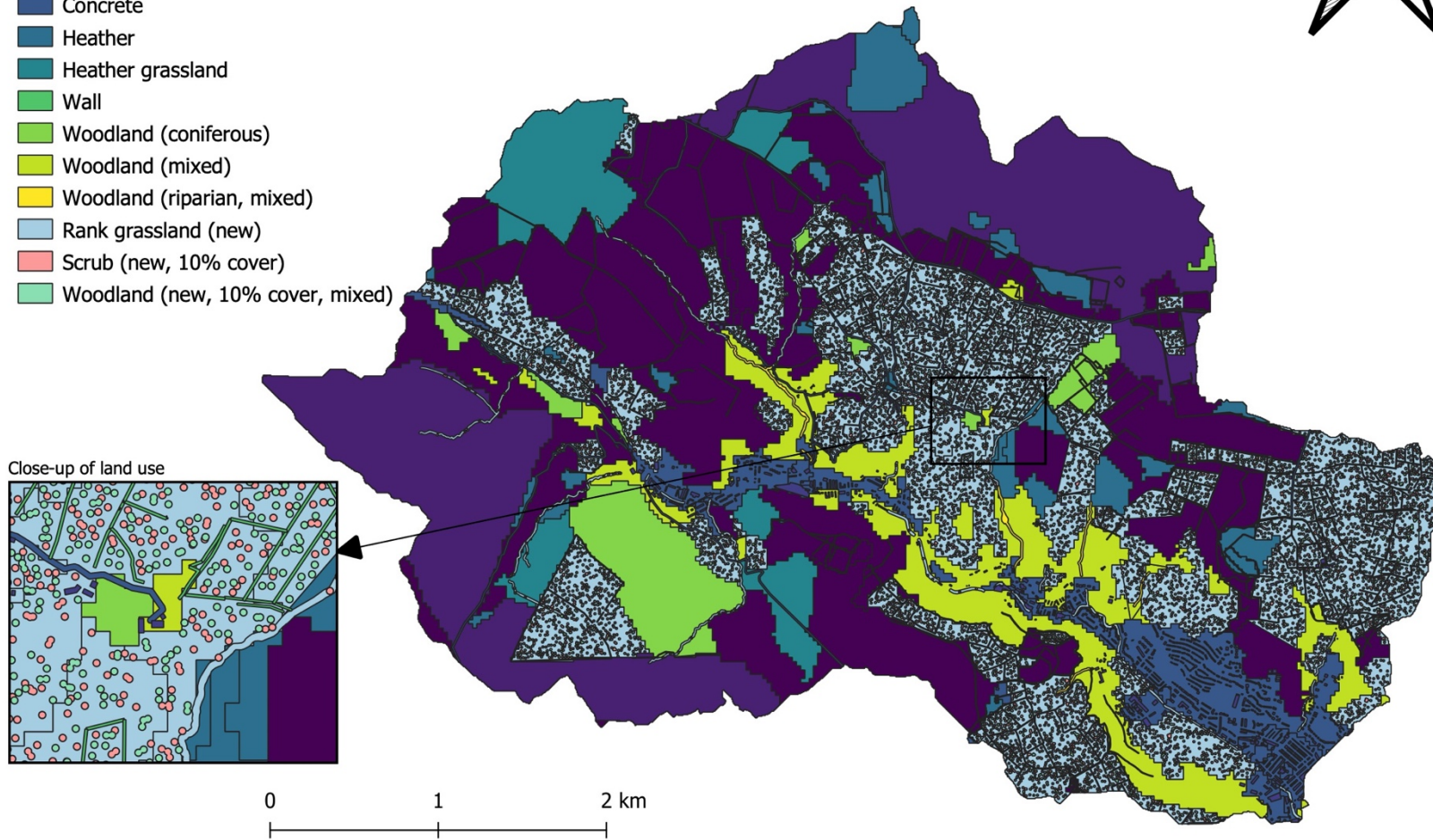

Figure C3.6: Map for Scenario C2\_4



Table C3.9: Parameters for re-wilding scenario C2\_4. Parameters are relative to the baseline value per land cover. Land covers differing from the baseline scenario are highlighted in blue.

<b>C2_4: Management: Catchment in 10-50 years' time if all management were removed. Scrub and woodland develop across 20% of the catchment</b>								
Baseline land cover	New land cover	How has the land cover changed from the baseline?	Kv		K		I <sub>n</sub>	
			Velocity, m s <sup>-1</sup>	Relative velocity	Median K <sub>s</sub> , m hr <sup>-1</sup>	Relative K	I <sub>n</sub> (%)	Map value (1-%)
Acid grassland	Acid grassland	Same as baseline	0.0273	1.0000	1.8000	1.0000	0	1
Bog	Bog	Same as baseline	0.0232	1.0000	1.8000	1.0000	0	1
Building	Building	Same as baseline	0.0504	1.0000	0.0010	1.0000	0	1
Concrete	Concrete	Same as baseline	0.0504	1.0000	0.0010	1.0000	0	1
Heather	Heather	Same as baseline	0.0430	1.0000	0.1647	1.0000	12	0.88
Heather grassland	Heather grassland	Same as baseline	0.0352	1.0000	0.1059	1.0000	6	0.94
Improved grassland	Rank grassland	Same as SD:Rank grassland annual	0.0257	0.8893	0.0993	7.7365	0	1
Riparian	Rank grassland	Same as SD:Rank grassland annual	0.0257	1.0000	0.0993	1.0000	0	1
Wall	Wall	Same as baseline	0.0504	1.0000	0.0010	1.0000	0	1
Woodland (coniferous)	Woodland (coniferous)	Same as baseline	0.0430	1.0000	0.3711	1.0000	21	0.79
Woodland (mixed)	Woodland (mixed)	Same as baseline	0.0430	1.0000	0.3711	1.0000	13	0.87
Woodland (riparian, mixed)	Woodland (riparian, mixed)	Same as baseline	0.0430	1.0000	0.3711	1.0000	13	0.87
Improved grassland and riparian	Scrub	Random points 6.25m diameter. Kv is Woodland and K is Heather. Winter I <sub>n</sub> values (hedgerow Hawthorn).	0.043	1.6732	0.1647	1.6589	12	0.88
Improved grassland and riparian	Woodland (new)	Random points 6.25m diameter – the same points as Scrub in C2_3. Kv and K are Woodland values. Winter I <sub>n</sub> values (mixed woodland).	0.043	1.6732	0.3711	3.7367	13	0.87

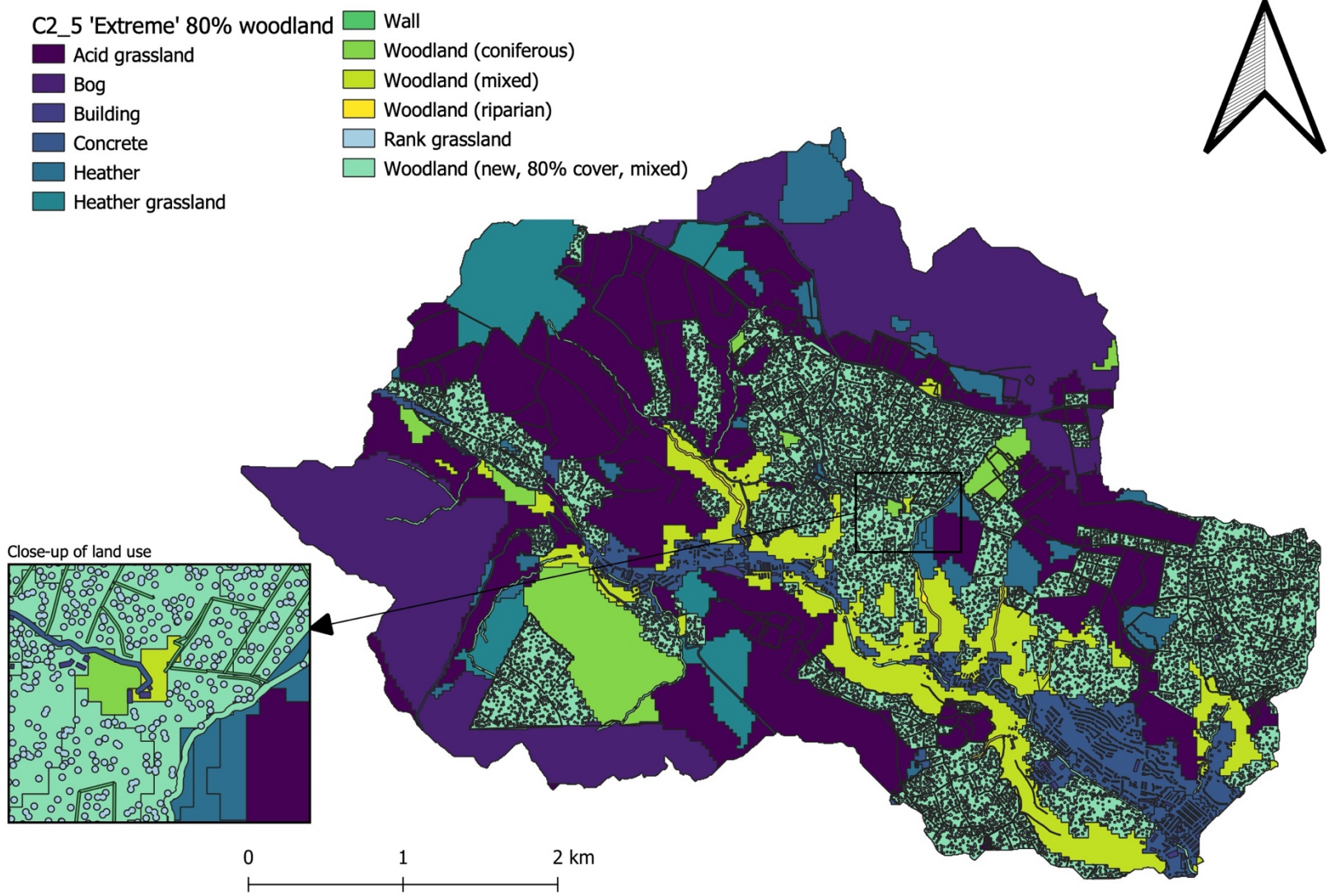

Figure C3.7: Map for Scenario C2\_5

Table C3.10: Parameters for re-wilding scenario C2\_5. Parameters are relative to the baseline value per land cover. Land covers differing from the baseline scenario are highlighted in blue.

<b>C2_5: Management: Extreme scenario. Catchment in 50+ years' time if all management were removed and woodland spread to cover 80% of the catchment.</b>								
Baseline land cover	New land cover	How has the land cover changed from the baseline?	Kv		K		I <sub>n</sub>	
			Velocity, m s <sup>-1</sup>	Relative velocity	Median K <sub>s</sub> , m hr <sup>-1</sup>	Relative K	I <sub>n</sub> (%)	Map value (1-%)
Acid grassland	Acid grassland	Same as baseline	0.0273	1.0000	1.8000	1.0000	0	1
Bog	Bog	Same as baseline	0.0232	1.0000	1.8000	1.0000	0	1
Building	Building	Same as baseline	0.0504	1.0000	0.0010	1.0000	0	1
Concrete	Concrete	Same as baseline	0.0504	1.0000	0.0010	1.0000	0	1
Heather	Heather	Same as baseline	0.0430	1.0000	0.1647	1.0000	12	0.88
Heather grassland	Heather grassland	Same as baseline	0.0352	1.0000	0.1059	1.0000	6	0.94
Improved grassland	Woodland - 80%	Random points 6.25m diameter – the same points as Scrub in C2_3. Kv and K are Woodland values. Winter I <sub>n</sub> values (Hawthorn).	0.0430	1.4879	0.3711	28.9206	0	0.87
Riparian	Woodland - 80%		0.0430	1.6732	0.3711	3.7382	0	0.87
Wall	Wall	Same as baseline	0.0504	1.0000	0.0010	1.0000	0	1
Woodland (coniferous)	Woodland (coniferous)	Same as baseline	0.0430	1.0000	0.3711	1.0000	21	0.79
Woodland (mixed)	Woodland (mixed)	Same as baseline	0.0430	1.0000	0.3711	1.0000	13	0.87
Woodland (riparian, mixed)	Woodland (riparian, mixed)	Same as baseline	0.0430	1.0000	0.3711	1.0000	13	0.87
Improved grassland and riparian	Rank grassland	Same as SD:Rank grassland	0.0257	0.8893	0.0993	7.7365	13	1

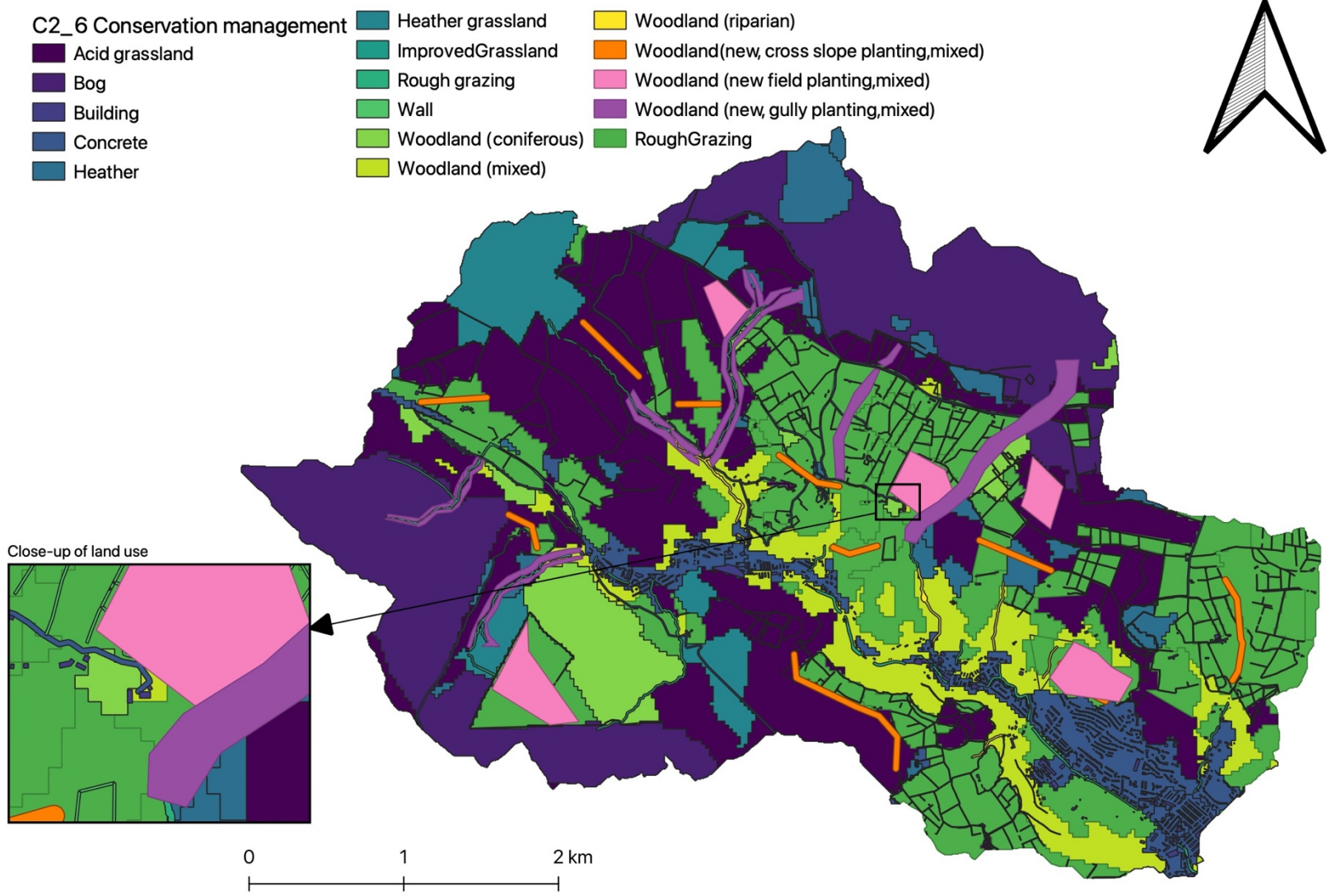

Figure C3.8: Map for Scenario C2\_6

Table C3.11: Parameters for re-wilding scenario C2\_6. Parameters are relative to the baseline value per land cover. Land covers differing from the baseline scenario are highlighted in blue.

<b>C2_6: Management: Conservation management. Haymeadows are maintained for biodiversity, rank grassland and bracken are converted to woodland and scrub, low-density grazing is introduced.</b>								
Baseline land cover	New land cover	How has the land cover changed from the baseline?	Kv		K		I <sub>n</sub>	
			Velocity, m s <sup>-1</sup>	Relative velocity	Median K <sub>s</sub> , m hr <sup>-1</sup>	Relative K	I <sub>n</sub> (%)	Map value (1-%)
Acid grassland	Acid grassland	Same as baseline	0.0273	1.0000	1.8000	1.0000	0	1
Bog	Bog	Same as baseline	0.0232	1.0000	1.8000	1.0000	0	1
Building	Building	Same as baseline	0.0504	1.0000	0.0010	1.0000	0	1
Concrete	Concrete	Same as baseline	0.0504	1.0000	0.0010	1.0000	0	1
Heather	Heather	Same as baseline	0.0430	1.0000	0.1647	1.0000	12	0.88
Heather grassland	Heather grassland	Same as baseline	0.0352	1.0000	0.1059	1.0000	6	0.94
Improved grassland	Rough Grazing	Rough Grazing	0.0273	0.9455	0.0470	3.6642	0	1
Riparian	Riparian	Same as baseline	0.0257	1.0000	0.0993	1.0000	0	1
Wall	Wall	Same as baseline	0.0504	1.0000	0.0010	1.0000	0	1
Woodland (coniferous)	Woodland (coniferous)	Same as baseline	0.0430	1.0000	0.3711	1.0000	21	0.79
Woodland (mixed)	Woodland (mixed)	Same as baseline	0.0430	1.0000	0.3711	1.0000	13	0.87
Woodland (riparian, mixed)	Woodland (riparian, mixed)	Same as baseline	0.0430	1.0000	0.3711	1.0000	13	0.87
Primarily Acid grassland and Improved grassland	Cross slope woodland (mixed)	Cross slope woodland (mixed). Blocks of woodland planting perpendicular to the slope	0.0430	1.5296	0.3711	0.4121	13	0.87
	Field woodland (mixed)	Field woodland (mixed). Blocks of woodland in specific fields. Relative to the average of Acid grassland and Improved grassland	0.0430	1.5296	0.3711	0.4094	13	0.87
	Gully woodland (mixed)	Gully woodland (mixed). Widens riparian woodland. Relative to the average of Acid grassland and Improved grassland	0.0430	1.5296	0.3711	0.4094	13	0.87

## References

- Bond, S., Kirkby, M. J., & Holden, J. (2021). Upland grassland management influences organo-mineral soil properties and their hydrological function. *Ecohydrology*, e2336.
- Bond, S., Kirkby, M. J., Johnston, J., Crowle, A., & Holden, J. (2020). Seasonal vegetation and management influence overland flow velocity and roughness in upland grasslands. *Hydrological Processes*, 34(18), 3777-3791.
- Branham, J. E., & Strack, M. (2014). Saturated hydraulic conductivity in Sphagnum-dominated peatlands: do microforms matter? *Hydrological Processes*, 28(14), 4352-4362.
- Gao, J., Holden, J., & Kirkby, M. (2015). A distributed TOPMODEL for modelling impacts of land-cover change on river flow in upland peatland catchments. *Hydrological Processes*, 29(13), 2867-2879.
- Gash, J., Wright, I., & Lloyd, C. R. (1980). Comparative estimates of interception loss from three coniferous forests in Great Britain. *Journal of Hydrology*, 48(1-2), 89-105.
- Herbst, M., Roberts, J. M., Rosier, P. T., & Gowing, D. J. (2006). Measuring and modelling the rainfall interception loss by hedgerows in southern England. *Agricultural and Forest Meteorology*, 141(2-4), 244-256.
- Herbst, M., Rosier, P. T., McNeil, D. D., Harding, R. J., & Gowing, D. J. (2008). Seasonal variability of interception evaporation from the canopy of a mixed deciduous forest. *Agricultural and Forest Meteorology*, 148(11), 1655-1667.
- Holden, J., Kirkby, M. J., Lane, S. N., Milledge, D. G., Brookes, C. J., Holden, V., & McDonald, A. T. (2008). Overland flow velocity and roughness properties in peatlands. *Water Resources Research*, 44(6).
- Kingsbury-Smith, L. E. (2019). *Testing the effectiveness of land use management as a natural flood management technique*. (Masters by Research), University of Leeds.
- Monger, F., Bond, S., Spracklen, D., & Kirkby, M. (2022). Overland flow velocity and soil properties in established semi-natural woodland and wood pasture in an upland catchment. *Hydrological Processes*, e14567.
- Willis, T. D., & Klaar, M. J. (2021). *NFM Calderdale Summary Modelling Report*. Available at: <https://icasp.org.uk/projects-2-2/calderdale-nfm-2/>: iCASP. [Accessed 16/02/2022]

## C.4 Swindale IDF curve

Figure C4.1 shows the Intensity-Duration-Frequency (IDF) curve for Mickleden station, approximately 24 km SWW of Swindale (Middle Fell Farm telemetry, Station number 586820, NY 28 06). Storm Ciara, used to validate SD-TOPMODEL for Swindale, is a 1 in 2-year rainfall event (over 48 hours).

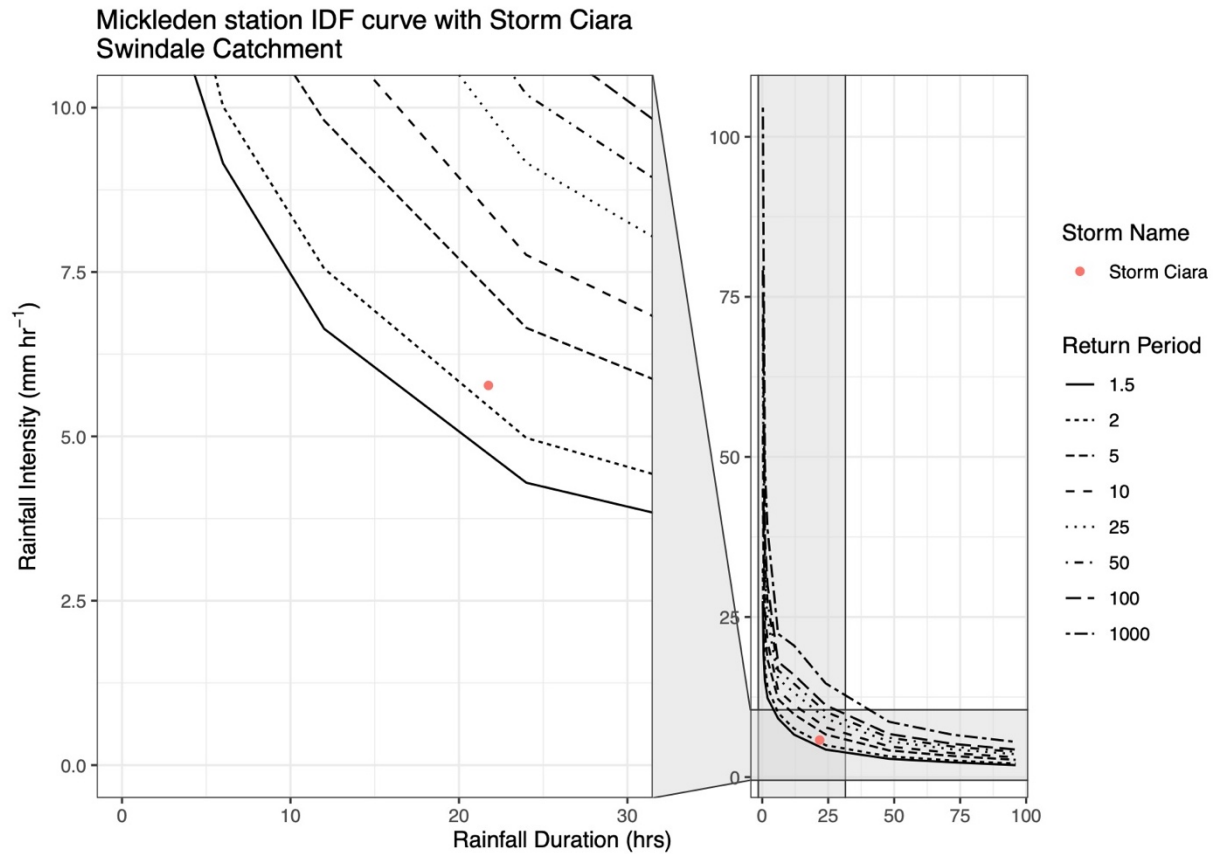

Figure C4.1: IDF curve for Mickleden gauge near Swindale. Storm Ciara plotted.

## Appendix D. Initialisms, acronyms, and abbreviations used in this thesis

Table D.1: Abbreviations used in this thesis

Abbreviation	Full term
<b>7EAP</b>	Seventh Environmental Action Programme
<b>CAP</b>	Common Agricultural Policy
<b>CBA</b>	Catchment based approach
<b>CEH</b>	Centre for Ecology and Hydrology
<b>CIRIA</b>	Construction Industry Research and Information Association
<b>CIWEM</b>	Chartered Institute for Water and Environmental Management
<b>DEFRA</b>	Department for Environment, Food and Rural Affairs (UK)
<b>DEM</b>	Digital elevation model
<b>EA</b>	Environment Agency (UK)
<b>Eco-DRR</b>	Ecosystem-based Disaster Risk Reduction
<b>ELMS</b>	Environmental Land Management Scheme
<b>FFS</b>	Future farming schemes
<b>HLS</b>	Higher level stewardship
<b>HRU</b>	Hydrologic response unit
<b><math>K</math></b>	Parameter $K$ , the hydraulic conductivity of the soil
<b><math>K_s</math></b>	Saturated hydraulic conductivity
<b><math>K_v</math></b>	Parameter $K_v$ , an overland flow velocity parameter which is related to surface roughness
<b><math>m</math></b>	Parameter $m$ , representing active water storage within the soil
<b>NBFP</b>	Nature-based flood protection
<b>NBS</b>	Nature-based solutions
<b>NFM</b>	Natural flood management
<b>NSE</b>	Nash-Sutcliffe efficiency
<b>NWRM</b>	Natural Water Retention Measures
<b>OLF</b>	Overland flow
<b>OM</b>	Organo-mineral
<b>ReFH</b>	Model name:
<b>SD-TOPMODEL</b>	Spatially-distributed TOPMODEL
<b>SEPA</b>	Scottish Environment Protection Agency
<b>SM</b>	Soil moisture
<b>SOC</b>	Soil organic carbon
<b>SOM</b>	Soil organic matter
<b>SSG</b>	Soil subgroup
<b>SuDs</b>	Sustainable urban drainage
<b>TOM</b>	Total organic matter
<b>WRB</b>	World reference base
<b>WWNP</b>	Working with natural processes



---

**Habitat abbreviations used in Chapters Two and Four**

---

Abbreviation	Full term
<b>Chapter Two</b>	
<b>B</b>	Bracken
<b>E</b>	Excluded
<b>GG</b>	Good grazing
<b>RG</b>	Rough grazing
<b>Chapter Four</b>	
<b>AG</b>	Acid grassland
<b>B</b>	Bracken
<b>Bd</b>	Buildings
<b>C</b>	Crag
<b>Co</b>	Concrete
<b>DW</b>	Drystone wall
<b>GG</b>	Improved grassland: Good grazing
<b>H</b>	Heather
<b>HG</b>	Heather grassland
<b>HM</b>	Hay Meadows
<b>IG</b>	Improved grassland
<b>MC</b>	Mardale Common
<b>MD</b>	Mosedale
<b>PB</b>	Peat bog
<b>R</b>	Rushes
<b>RG</b>	Rank Grassland
<b>RiG</b>	Riparian grassland
<b>RoG</b>	Improved grassland: Rough Grazing
<b>RRC</b>	Rosgil and Ralfland Common
<b>S</b>	Scree
<b>UR</b>	Urban and Roads
<b>WC</b>	Woodland (coniferous)
<b>WM</b>	Woodland (mixed)
<b>WR</b>	Woodland (riparian, mixed)

---