

2021-12

A Battery Voltage Level Monitoring System for Telecommunication Towers

Uwamahoro, Rahab

Engineering, Technology & Applied Science Research

<https://dspace.nm-aist.ac.tz/handle/20.500.12479/1616>

Provided with love from The Nelson Mandela African Institution of Science and Technology

A Battery Voltage Level Monitoring System for Telecommunication Towers

Rahab Uwamahoro

School of Computational and Communication Sciences and Engineering
The Nelson Mandela African Institution of Science and Technology
Arusha, Tanzania

Neema Mduma

School of Computational and Communication Sciences and Engineering
The Nelson Mandela African Institution of Science and Technology
Arusha, Tanzania

Dina Machuve

School of Computational and Communication Sciences and Engineering
The Nelson Mandela African Institution of Science and Technology
Arusha, Tanzania

Abstract-Voltage fluctuations in batteries form a major challenge the telecommunication towers face. These fluctuations mostly occur due to poor management and the lack of a battery voltage level monitoring system. The current paper presents a battery voltage-level monitoring system to be used in telecommunication towers. The proposed solution is incorporated with a centralized mobile application dashboard for accessing the live data of the installed battery, integrated with voltage-level, current, temperature, fire, and gas sensors. An Arduino Uno microcontroller board is used to process and analyze the collected data from the sensors. The Global Service Message (GSM) module is used to monitor and store data to the cloud. Users are alerted in the case of low voltage, fire, and increase in harmful gases in the tower through Short Message Service (SMS). The experiment was conducted at Ngorongoro and Manyara telecommunication towers. The developed system can be used in accessing battery information remotely while allowing real-time continuous monitoring of battery usage. The proposed battery voltage-level monitoring system contributes to the elimination of battery hazards in towers. Therefore, the proposed battery voltage level monitoring system can be adopted by telecommunication tower engineers for the reduction of voltage fluctuation risks.

Keywords-battery voltage level monitoring; telecommunication towers; renewable energy; GSM sim 8001 module; dashboard

I. INTRODUCTION

Rapidly growing population, technological advancements, and climate change, raise the demand for more energy [1], which is expected to increase the Greenhouse Gas (GHG) emissions in the atmosphere. Global population, for instance, is expected to increase from 7.7 to 9 billion by 2050 [2], whereas, in Sub-Saharan Africa, where Tanzania is located, the population is predicted to double by 2050 [3]. Also, 80% of the 1.4 billion of the global population living in rural areas have inadequate access to electricity [4, 5]. These people not only

have a low life quality but also lack access to technology, which means that they fall under the energy poverty deception category. The instability of the national grid and the low proportion of the population accessing it, makes renewable energy a priority for electrification, especially in Africa, since it is low-cost, user-friendly, and can reduce carbon footprint [6]. Telecom tower companies in Tanzania have found significant reliable use of renewable energy by using solar panels to power their services during power outages and hence enabling a cost-efficient evolution to a low-carbon power system [7]. The advancements in solar energy are increasing in Tanzania [8]. However, solar energy offers efficient production only during the day. This necessitates energy storage in batteries to ensure the continuation of services [9-12].

Telecom towers connect people with their business remotely by accessing the internet and other services. Powering the towers requires a stable energy source for versatile operations. To guarantee their uninterrupted operation, the towers need to depend on renewable energy sources, like solar panels, to eliminate the inconveniences caused by unpredictable power cuts on the national grid [13, 14]. The most serious challenge encountered by telecom towers is the unexpected voltage drops followed by cutoffs that occur without alerting users to act accordingly. This makes the tower services unavailable, thus lowering productivity while putting sensitive electrical equipment at risk. Additionally, the hydrogen gas from batteries affects human health and the environment [15-17]. So, there is a need to monitor and eliminate battery voltage-level changes and other parameters that may pose a threat to public health and safety. Among the factors that have been identified as the primary contributors to voltage fluctuations are the lack of battery data visualization and the big number of devices allocated to be powered by a battery [18]. They, therefore, lack information with regard to when the voltage battery is expected to be low for timely actions. With the technological advancements through the

Corresponding author: Rahab Uwamahoro (uwamahoro@nm-aist.ac.tz)

Internet of Things (IoT), accessing data remotely has been a routine for many companies and individuals. IoT is proved to be fundamental in receiving, controlling, and accessing data remotely and acting accordingly. The technology is also user-friendly and grants real-time data access [19, 20]. Taking advantage of this technological advancement, some studies have been carried out to review, analyze, monitor, and compute data for real-time sensing in different areas [21, 22]. However, most of these studies have only concentrated on monitoring geographical areas and excluded monitoring batteries installed in towers.

Several measuring components have been used to monitor voltage fluctuations in batteries. Voltage changes in batteries have been reviewed to identify battery parameters that can be at risk due to voltage changes in order to improve the economic and sustainable use of their energy [23]. One recent approach included the integration of an Arduino microcontroller board with thermometer, voltmeter, and ammeter sensors through a correlation and regression algorithm to measure the battery's state of charge and estimate its useful remaining life [24]. The study showed that battery estimation on the state of charge, state of health, and discharge rate with its remaining useful life can be derived in real-time. However, this system failed to estimate the remaining voltage of the battery and presented a low real-time data acquisition due to the usage of an SD-card which lacks efficiency in data security. So, there is a need to develop a low-cost, efficient battery voltage-level monitoring system to increase the sustainable utilization of the voltage stored in the battery remotely. Authors in [25] conducted a simulation work on discharging and charging of battery banks for telecom sites in India. Similar work was conducted in [26], again in India, aimed to control the voltage drop of the battery bank. However, these works were limited only on the simulation approach without being tested to real life applications. Authors in [27] presented a review on the methods of monitoring the charging and discharging of batteries connected to renewable energy sources through a centralized controller. However, they took into consideration only the energy supplied to the load without alerting the user on battery discharge and charge. Changes in current, temperature, and the state of health of the battery are considered as the factors affecting the most voltage fluctuation in batteries installed in electric vehicles, which is only beneficial to only a section of battery users [28]. Besides, some studies use high technological methods which turn away most users from adopting them due to their high costs and requirements of high technical skills to operate [29].

Sustainable Development Goal (SDG) number 7 is to ensure access to modern, affordable, clean, and reliable energy for all by 2030 [30]. However, the previous works have failed to contribute to the accomplishment of this goal. To eliminate these challenges, the present study proposes a low battery voltage level monitoring system that can be beneficial to all battery users in accessing battery information remotely by allowing them to continuously monitor the battery usage in real-time and contribute to the elimination of battery hazards. With this, attention needs to be drawn to a cost-effective and user-friendly battery voltage-level monitoring system. This will contribute to real-time access of information about faults in

batteries and consumption, through a dashboard for the sustainability of usage.

II. MATERIALS AND METHODS

This study was carried out at 2 towers of Habari Node Public Limited Company which is an Internet Service Provider (ISP) in Arusha, Tanzania. Firstly, coordinates of the towers were measured with GPRS devices, as shown in Table I. The two towers were selected due to their ability to store energy in batteries. Also, they are most affected by voltage fluctuations due to the huge number of users residing far from company offices. The coordinate measurements helped in sending data to the towers accurately without any data loss. Furthermore, the measured coordinates assisted system installation and the testing process in the field.

TABLE I. TOWER LOCATIONS

| Location | Coordinates | |
|------------|----------------|------------------|
| | Latitude (LAT) | Longitude (LONG) |
| Ngorongoro | -3.27544 | 35.438886 |
| Manyara | -3.37764 | 35.81857 |

The voltage levels of the installed batteries and solar panels in the tower were measured. The currents through the batteries and the solar panels were measured manually with a digital AC/DC UNI-T UT890D multimeter. The measurements were conducted on two batteries located in Ngorongoro tower and Manyara tower as shown in Table II. The results present a mix of used and full batteries with different values. Furthermore, their cutoff times were observed based on the voltage stored in the batteries. The measurements helped in the development and real application of the proposed system.

TABLE II. MANUAL MEASUREMENT RESULTS

| Battery location | Voltage | | | | Results |
|------------------|---------|-------|------|-------------|------------|
| | Battery | Solar | Load | Low voltage | Time (hrs) |
| Ngorongoro | 14.8V | 20V | 0.05 | 11.88V | 6 |
| Manyara | 14.5V | 20V | 0.07 | 11.8V | 4 |

A. Hardware Integration

After data collection, verification of the hardware part was done using the Proteus simulation software. Figure 1 shows the system overview design in the circuit, which consists of voltage sensor, current sensor, gas sensor, frame sensor, an Arduino Uno microcontroller board, the SIM808 GSM/GPRS/GPS module, a 14.8V to 14.5 V battery for power supply, and a 20V solar panel. Simulations were conducted before the real application of the integrated circuit components to ensure they behaved efficiently. The components were integrated into the Proteus software. Arduino Uno, was selected due to its efficiency to help the development of the proposed low-cost system. It consists of 14 digital input and output pins and 6 analog pins. The voltage sensor which acts as a voltage divider was connected to measure the voltage level of the batteries and solar panels. The GSM module transmitter (Tx) and receiver (Rx) pins were connected to pins 0 and 1 respectively. The fire sensor was connected to pin 2 of the Arduino and the gas sensor was connected to pin 10. Furthermore, two relays were connected, one to allow the voltage from the solar panel to go

to the battery and the other to allow the load to function. The load used was a bubble light, tested at 5V at Ngorongoro and 3V at Manyara. Four Light-Emitting Diode (LED) indicators were used to alert the user if any hazard was happening near the batteries. The red LEDs represent hazard, the blue network connection, the yellow represent the relay, and the green was for power. A long leg pin was connected to pin 10 of the Arduino and set to the output of the GSM module. In real life

system application, a short message notification was used as an alert to the user with the help of the GSM module. The GSM was powered by 12V and the other components were supplied with 5V voltage from the Arduino. After system simulation, the hardware components were integrated for real-life application and their interactions proved the system functionality and its compliance with the requirements. Figure 2 shows the prototype integration of the GSM and the sensors.

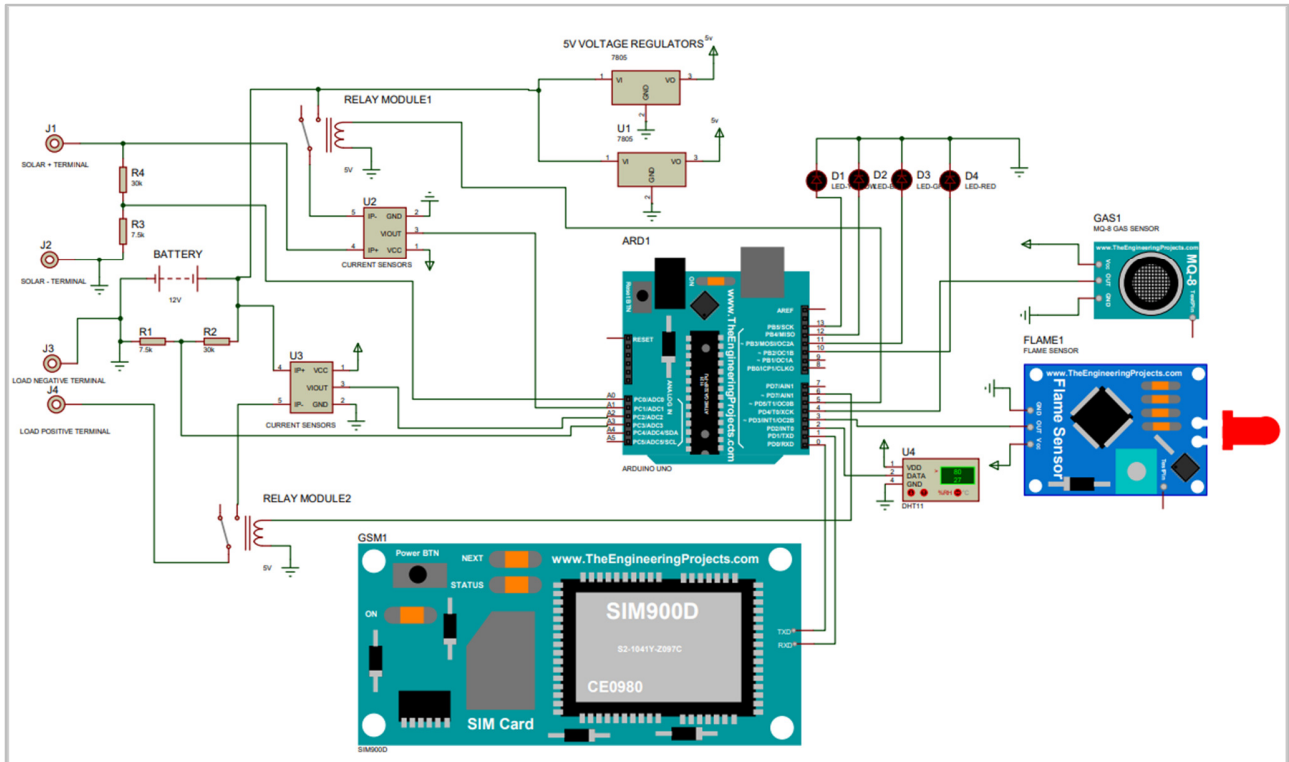

Fig. 1. Circuit diagram of the developed system.

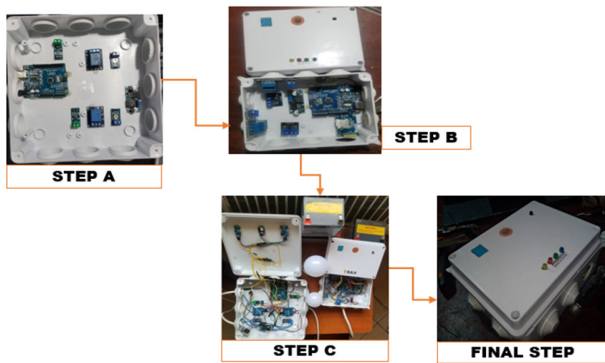

Fig. 2. Prototype integration.

B. Calculations

The calculations shown below helped in producing reliable and accurate voltages to the batteries and the solar panels. The values read by the analog pin of the Arduino were converted and the voltage stored in the battery was considered to be the

battery voltage. Let the value to be read by the analog pin be the ADC-Value as shown in (1):

$$ADC\ Voltage\ Value \times \frac{5}{1024} \quad (1)$$

where ADC represents the Analog to Digital Converter, 5 is the reference voltage of the Arduino, and 1024 is the ADC resolution. The formula for calculating the voltage divider is:

$$\frac{R3}{R3+R4} = Ratio \quad (2)$$

The resistances R3 and R4 are presented in Figure 3. R4 in this work was 30KΩ and R3 was 7.5KΩ. Therefore, the voltage divider is 37.5KΩ. The ADC voltage is calculated as shown in (3), (4), and Figure 3.

$$ADC\ voltage = \frac{R3}{R3+R4} \times Battery\ Voltage \quad (3)$$

Therefore:

$$ADC\ voltage = \frac{7.5\ Kilohms}{37.5\ Kilohms} \times Battery\ Voltage \quad (4)$$

From (1), the *ADC-Voltage* is calculated as:

$$ADC \text{ Voltage} = ADC \text{ value} \times 0.00489 \quad (5)$$

Substitution of *ADC-Voltage* in (3) gives (6):

$$ADC \text{ Value} \times 0.0049 = \frac{7.5 \text{ K}\Omega}{37.5 \text{ K}\Omega} \times \text{Battery Voltage} \quad (6)$$

For 0.02444 *ADC-Value*, the *solar-volt* is shown in (7).

$$\text{Solar} - \text{volt} = 0.2445 \times ADC \text{ Value} \quad (7)$$

Therefore, the voltage constant used in the code battery was 0.02499999 and for the solar constant, it was 0.02499989.

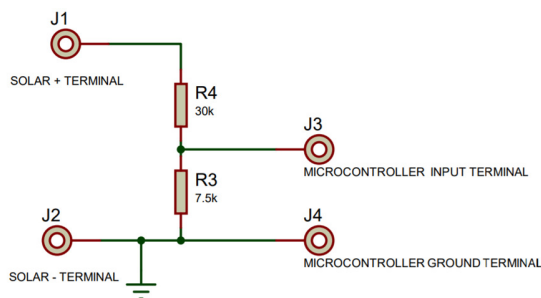

Fig. 3. Voltage divider.

III. RESULTS AND DISCUSSION

This section contains the results of the system's tests and analysis. The voltage sensor experiment was recorded to ensure that the circuit was in good working order followed by recording experiments and results used to verify battery voltage fluctuations as shown in Table III. Analysis was conducted for the proposed system and the two batteries located in the respective towers as shown in Figure 4. Their voltage levels and the current from solar panels and the load were successfully measured by the developed system as shown in Table III. Furthermore, the system could measure the humidity of the battery and detect gas and fire near the battery. A 14.8V fully-charged battery which reached 11.86V after usage was used for the Ngorongoro tower and an 11.85V used rechargeable solar battery for the Manyara tower. A voltmeter was used to compare the voltage measured manually with the voltage measured by the system as shown in Table III. The two voltages were found to be the same. This helped to know the voltage level of the batteries before they reached low voltage. The GSM could send SMS notifications to the intended users to act accordingly. The other parameters were monitored similarly. The measurements taken manually with a multimeter showed that the voltage level was different due to the usage of different batteries. Figure 4(a) shows the solar battery used in the experiment, Figure 4(b) shows the prototype testing with a voltmeter, and Figure 4(c) shows the complete prototype with 5V solar lamp as the load and solar panel.

TABLE III. RESULTS FROM THE DEVELOPED SYSTEM

| Battery | Voltage results | | Current | | Humidity | Gas | | Fire | |
|---------|-----------------|----------------|---------|------|----------|----------|--------------|----------|--------------|
| | Multimeter (V) | Voltage sensor | Solar | Load | | Detected | Not detected | Detected | Not detected |
| 1 | 11.86V | 11.87V | 20V | 0.00 | Good | No | Yes | No | Yes |
| 2 | 11.85V | 11.86V | 20V | 0.03 | Good | No | Yes | No | Yes |

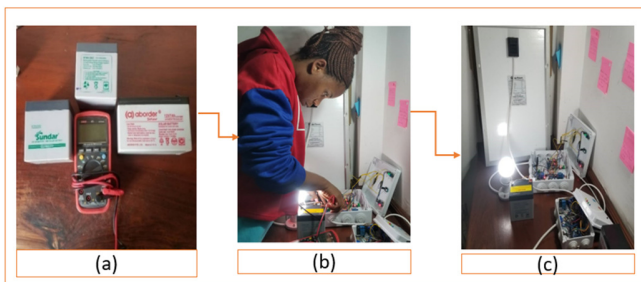

Fig. 4. System testing.

From the multimeter measurements, the value was accurately similar to the one measured using the system as shown in Table III. It can, therefore, be concluded that the voltage sensor provides valid measurement values of the batteries. The other battery parameters were measured to determine whether they could be risky to humans and the environment. Using current as an example, the current sensor load and the DC for which a solar panel was used to charge the batteries were respectively measured. The solar panel was able to charge the battery, the lamp was used as a load, and its current was measured and monitored respectively as shown in Figure 4. Battery voltage data were sent to one centralized mobile application dashboard.

A. The Dashboard Data

Figure 5 shows the final prototype of both systems tested for Ngorongoro and Manyara towers. Data from the sensors were collected and sent to a mobile app dashboard as shown in Figure 6. The battery parameters were updated every 5s, they were stored in the cloud using the ThingsWeb server, and were displayed on the Arduino IDE serial monitor. The actual voltage and current comparison were used to control the voltage level of the battery installed in each tower. The comparison was done based on measuring the actual battery voltage to the remainder, and the current coming from the solar panel to the battery to the actual current. Furthermore, temperature, humidity, fire, and gas were continuously monitored to assess whether they were detected or not. As shown in Figure 6, the screenshot of the app developed for monitoring the batteries shows that the approach was effectively evaluated and met the requirements in instances of live data every 5s. Figure 7 shows the screenshot of a message received as an alert to the user about the low voltage of the battery installed at Ngorongoro tower which enabled the user to turn on the relay. Data were uploaded onto the dashboard and stored on a server. When the load was connected and the solar panel begun to power the battery, the current was efficiently measured by the system as shown in Figure 7. The load charging current was 0.32 since the 5V solar lamp was

connected as the load and the solar panel current was 0.32 as it was charging the low battery. Fire and gas were not detected at the Ngorongoro tower. Furthermore, the system was able to alert the user of the low battery voltage 11.8V at the Ngorongoro tower using a message sent by the GSM project (Figure 7).



Fig. 5. Final prototypes for Manyara and Ngorongoro towers.

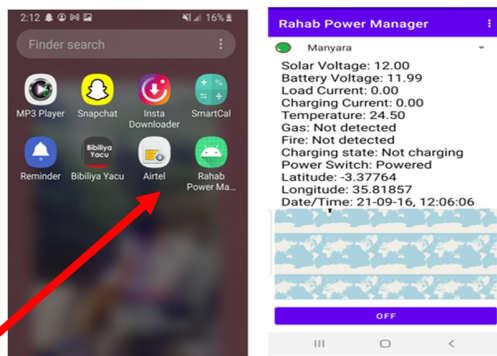

Fig. 6. The developed mobile application dashboard.

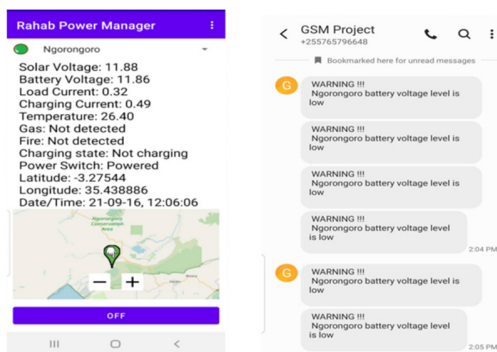

Fig. 7. Short message alert received from the system installed at Ngorongoro.

B. Discussion

The conducted experiments proved the validity of the status information from batteries located in the telecommunication towers: their voltage and current levels, temperatures, and presence of fire or gas were monitored while the risks of voltage fluctuation were reduced. Figures 6 and 7 show the monitoring and access through the mobile dashboard of the

voltage level and other battery status parameters from the battery located at the Ngorongoro tower. Data processed from the sensor were sent in real-time to the cloud and battery voltage level, current, temperature, fire warning, and gas status were visualized through the mobile app dashboard as shown in Figures 5 and 6.

IV. CONCLUSION AND FUTURE WORK

The current work lays the foundation for the development of a battery voltage level monitoring system for communication towers to ensure suitable battery performance and real-time monitoring. The development of the system consisted of the integration of sensors for battery monitoring devices and a dashboard as a user interface which ensures central monitoring. The system can send information to the administrator dashboard via a cloud server from the related towers using its coordinate locations via the GPRS internet module. An SMS notification is sent to the user as an alert when the battery voltage becomes low. The dashboard allows real-time access and monitoring of the battery status. Future research can add more functionality to the current work, e.g. by adding Ethernet that can be used to improve internet connectivity over GPRS.

ACKNOWLEDGEMENT

The authors would like to thank the Center of Excellence for ICT in East African (CENIT@EA), the Nelson Mandela African Institution of Science and Technology (NM-AIST), Dr. Elizabeth Mkoba from NM-AIST, the industry supervisor Mr. Lomayani Solomon from HABARI NODE PLC in Arusha, and Mr. Judah A. Robert, chief technical officer of Automatenics Technologies Company in Nigeria.

REFERENCES

- [1] J. N. Bhanutej and R. C. Naidu, "A 7-level inverter with less number of switches for grid-tied PV applications," *International Journal of Advanced Technology and Engineering Exploration*, vol. 8, no. 78, pp. 631-642, 2021, <https://doi.org/10.19101/IJATEE.2021.874090>.
- [2] "Growing at a slower pace, world population is expected to reach 9.7 billion in 2050 and could peak at nearly 11 billion around 2100 | UN DESA," *United Nations Department of Economic and Social Affairs*. <https://www.un.org/development/desa/en/news/population/world-population-prospects-2019.html> (accessed Nov. 06, 2021).
- [3] "Africa's population will double by 2050," *The Economist*, Mar. 26, 2020.
- [4] K. Kaygusuz, "Energy for sustainable development: A case of developing countries," *Renewable and Sustainable Energy Reviews*, vol. 16, no. 2, pp. 1116-1126, Feb. 2012, <https://doi.org/10.1016/j.rser.2011.11.013>.
- [5] "Report: Universal Access to Sustainable Energy Will Remain Elusive Without Addressing Inequalities," Jun. 2021, Accessed: Nov. 06, 2021. [Online]. Available: <http://119.78.100.173/C666/handle/2XK7JSWQ/329629>.
- [6] L. Odarno, E. Sawe, M. Swai, M. J. J. Katyega, and A. Lee, *Accelerating Mini-grid Deployment in Sub-Saharan Africa: Lessons from Tanzania*. Washington, DC, USA: World Resources Institutes, 2017.
- [7] R. Kaur, V. Krishnasamy, N. K. Kandasamy, and S. Kumar, "Discrete Multiobjective Grey Wolf Algorithm Based Optimal Sizing and Sensitivity Analysis of PV-Wind-Battery System for Rural Telecom Towers," *IEEE Systems Journal*, vol. 14, no. 1, pp. 729-737, Mar. 2020, <https://doi.org/10.1109/JSYST.2019.2912899>.

- [8] "TANZANIA: Greenlight energises 1.5 million people with solar kits," *Afrik 21*, Mar. 27, 2020. <https://www.afrik21.africa/en/tanzania-greenlight-energises-1-5-million-people-with-solar-kits/> (accessed Nov. 06, 2021).
- [9] B. Y. Lucien, J. B. Byiringiro, B. W. Abraham, G. B. Aristide, and K. Célestin, "Evaluation of the Criteria in the Choice of Energy Storage or Non-Storage in Photovoltaic Systems in the Sahelian Zone," *Energy and Power Engineering*, vol. 13, no. 6, pp. 236–242, Jun. 2021, <https://doi.org/10.4236/epe.2021.136016>.
- [10] M. H. Chakrabarti, S. A. Hajimolana, F. S. Mjalli, M. Saleem, and I. Mustafa, "Redox Flow Battery for Energy Storage," *Arabian Journal for Science and Engineering*, vol. 38, no. 4, pp. 723–739, Apr. 2013, <https://doi.org/10.1007/s13369-012-0356-5>.
- [11] Z. Yi, W. Dong, and A. H. Etemadi, "A Unified Control and Power Management Scheme for PV-Battery-Based Hybrid Microgrids for Both Grid-Connected and Islanded Modes," *IEEE Transactions on Smart Grid*, vol. 9, no. 6, pp. 5975–5985, Nov. 2018, <https://doi.org/10.1109/TSG.2017.2700332>.
- [12] Q. Li, Y. Liu, S. Guo, and H. Zhou, "Solar energy storage in the rechargeable batteries," *Nano Today*, vol. 16, pp. 46–60, Oct. 2017, <https://doi.org/10.1016/j.nantod.2017.08.007>.
- [13] P. K. Dalela, S. Basu, A. Singh, S. Majumdar, N. Nagpal, and V. Tyagi, "Geo-intelligence based carbon footprint monitoring and prediction of suitable renewable energy technology system for mobile towers," in *IEEE International Conference on Advanced Networks and Telecommunications Systems*, New Delhi, India, Dec. 2014, pp. 1–5, <https://doi.org/10.1109/ANTS.2014.7057244>.
- [14] Y. Kassem, H. Gokcekus, and H. S. A. Lagili, "A Techno-Economic Viability Analysis of the Two-Axis Tracking Grid-Connected Photovoltaic Power System for 25 Selected Coastal Mediterranean Cities," *Engineering, Technology & Applied Science Research*, vol. 11, no. 4, pp. 7508–7514, Aug. 2021, <https://doi.org/10.48084/etasr.4251>.
- [15] R. K. Lattanzio and C. E. Clark, "Environmental Effects of Battery Electric and Internal Combustion Engine Vehicles," Jun. 2020, Accessed: Nov. 06, 2021. [Online]. Available: <https://trid.trb.org/view/1718426>.
- [16] T. Gao, Z. Wang, S. Chen, and L. Guo, "Hazardous characteristics of charge and discharge of lithium-ion batteries under adiabatic environment and hot environment," *International Journal of Heat and Mass Transfer*, vol. 141, pp. 419–431, Oct. 2019, <https://doi.org/10.1016/j.ijheatmasstransfer.2019.06.075>.
- [17] A. Nedjalkov *et al.*, "Toxic Gas Emissions from Damaged Lithium Ion Batteries—Analysis and Safety Enhancement Solution," *Batteries*, vol. 2, no. 1, Mar. 2016, Art. no. 5, <https://doi.org/10.3390/batteries2010005>.
- [18] H. Sugihara, K. Yokoyama, O. Saeki, K. Tsuji, and T. Funaki, "Economic and Efficient Voltage Management Using Customer-Owned Energy Storage Systems in a Distribution Network With High Penetration of Photovoltaic Systems," *IEEE Transactions on Power Systems*, vol. 28, no. 1, pp. 102–111, Feb. 2013, <https://doi.org/10.1109/TPWRS.2012.2196529>.
- [19] N. L. M. Azemi and N. Wahid, "Uncertainty in internet of things: a review," *International Journal of Advanced Technology and Engineering Exploration*, vol. 8, no. 75, pp. 422–431, 2021, <https://doi.org/10.19101/IJATEE.2020.762115>.
- [20] S. Rawat and T. Arjariya, "An efficient Association based Optimization technique for Web pages," *International Journal of Advanced Technology and Engineering Exploration*, vol. 2, no. 5, pp. 54–59, 2015.
- [21] F. Wortmann and K. Fluchter, "Internet of Things," *Business & Information Systems Engineering*, vol. 57, no. 3, pp. 221–224, Jun. 2015, <https://doi.org/10.1007/s12599-015-0383-3>.
- [22] B. F. Alshammari and M. T. Chughtai, "IoT Gas Leakage Detector and Warning Generator," *Engineering, Technology & Applied Science Research*, vol. 10, no. 4, pp. 6142–6146, Aug. 2020, <https://doi.org/10.48084/etasr.3712>.
- [23] M. A. Hannan, Md. M. Hoque, A. Hussain, Y. Yusof, and P. J. Ker, "State-of-the-Art and Energy Management System of Lithium-Ion Batteries in Electric Vehicle Applications: Issues and Recommendations," *IEEE Access*, vol. 6, pp. 19362–19378, 2018, <https://doi.org/10.1109/ACCESS.2018.2817655>.
- [24] M. Maltezo *et al.*, "Arduino-based battery monitoring system with state of charge and remaining useful time estimation," *International Journal of Advanced Technology and Engineering Exploration*, vol. 8, no. 76, pp. 432–444, Mar. 2021, <https://doi.org/10.19101/IJATEE.2021.874023>.
- [25] D. K. Dhaked, Y. Gopal, and D. Birla, "Battery Charging Optimization of Solar Energy based Telecom Sites in India," *Engineering, Technology & Applied Science Research*, vol. 9, no. 6, pp. 5041–5046, Dec. 2019, <https://doi.org/10.48084/etasr.3121>.
- [26] T. V. Krishna, M. K. Maharana, and C. K. Panigrahi, "Integrated Design and Control of Renewable Energy Sources for Energy Management," *Engineering, Technology & Applied Science Research*, vol. 10, no. 3, pp. 5857–5863, Jun. 2020, <https://doi.org/10.48084/etasr.3613>.
- [27] N. A. Zainurin, S. a. B. Anas, and R. S. S. Singh, "A Review of Battery Charging - Discharging Management Controller: A Proposed Conceptual Battery Storage Charging - Discharging Centralized Controller," *Engineering, Technology & Applied Science Research*, vol. 11, no. 4, pp. 7515–7521, Aug. 2021, <https://doi.org/10.48084/etasr.4217>.
- [28] M. Faisal, M. A. Hannan, P. J. Ker, and M. N. Uddin, "Backtracking Search Algorithm Based Fuzzy Charging-Discharging Controller for Battery Storage System in Microgrid Applications," *IEEE Access*, vol. 7, pp. 159357–159368, 2019, <https://doi.org/10.1109/ACCESS.2019.2951132>.
- [29] D. Liu, X. Yin, Y. Song, W. Liu, and Y. Peng, "An On-Line State of Health Estimation of Lithium-Ion Battery Using Unscented Particle Filter," *IEEE Access*, vol. 6, pp. 40990–41001, 2018, <https://doi.org/10.1109/ACCESS.2018.2854224>.
- [30] "1.1 billion people still lack electricity. This could be the solution," *World Economic Forum*. <https://www.weforum.org/agenda/2018/06/1-billion-people-lack-electricity-solution-mini-grid-ica/> (accessed Nov. 06, 2021).

AUTHORS PROFILE



automation, and smart agriculture.

Rahab Uwamahoro received her Bachelor in Computer Science from the Kigali Independent University (ULK), Rwanda. Currently, she is taking her Masters in Embedded and Mobile system (EMOS) program, speciality in embedded systems at the Nelson Mandela African Institution of Science and Technology (NM-AIST) in Tanzania. Her research interest lies in digital solutions, renewable energy, smart home



L'Oréal UNESCO in 2020. Her research interests are artificial intelligence, machine learning, and data science.

Neema Mduma is a lecturer at the Nelson Mandela African Institution of Science and Technology (NM-AIST) in Tanzania. She got her PhD and MSc degrees in Information, Communication Sciences and Engineering from NM-AIST in 2020 and 2016 respectively. During her PhD, she developed a machine learning model called BakiShule which aimed at preventing students from dropping out of school. Neema's efforts towards women in science have been recognized through an award from



schools.

Dina Machuve is a Senior Lecturer and Researcher at the Nelson Mandela African Institution of Science and Technology (NM-AIST) in Tanzania. She holds a PhD in Information, Communication Science and Engineering from NM-AIST (2016), an MSc in Electrical Engineering from Tennessee Technological University, (2008), and a BSc in Electrical Engineering from the University of Dar Es Salaam (2001). Her research interests are data science and agriculture informatics in