

2QAN: A quantum compiler for 2-local qubit Hamiltonian simulation algorithms

Lingling Lao*

Department of Physics and Astronomy, University College
London
London, United Kingdom

Dan E. Browne

Department of Physics and Astronomy, University College
London
London, United Kingdom

ABSTRACT

Simulating quantum systems is one of the most important potential applications of quantum computers. The high-level circuit defining the simulation needs to be compiled into one that complies with hardware limitations such as qubit architecture (connectivity) and instruction (gate) set. General-purpose quantum compilers work at the gate level and have little knowledge of the mathematical properties of quantum applications, missing further optimization opportunities. Existing application-specific compilers only apply advanced optimizations in the scheduling procedure and are restricted to the CNOT or CZ gate set. In this work, we develop a compiler, named 2QAN, to optimize quantum circuits for 2-local qubit Hamiltonian simulation problems, a framework which includes the important quantum approximate optimization algorithm (QAOA). In particular, we exploit the flexibility of permuting different operators in the Hamiltonian (no matter whether they commute) and propose permutation-aware techniques for qubit routing, gate optimization and scheduling to minimize compilation overhead. 2QAN can target different architectures and different instruction sets. Compilation results on four applications (up to 50 qubits) and three quantum computers (namely, Google Sycamore, IBMQ Montreal and Rigetti Aspen) show that 2QAN outperforms state-of-the-art general-purpose compilers and application-specific compilers. Specifically, 2QAN can reduce the number of inserted SWAP gates by 11.5X, reduce overhead in hardware gate count by 68.5X, and reduce overhead in circuit depth by 21X. Experimental results on the Montreal device demonstrate that benchmarks compiled by 2QAN achieve the highest fidelity.

CCS CONCEPTS

• **Hardware** → **Quantum computation**; • **Software and its engineering** → **Compilers**.

KEYWORDS

Quantum computing, quantum simulation, quantum compilation

*Corresponding author: laolinglingrolls@gmail.com

Permission to make digital or hard copies of all or part of this work for personal or classroom use is granted without fee provided that copies are not made or distributed for profit or commercial advantage and that copies bear this notice and the full citation on the first page. Copyrights for components of this work owned by others than the author(s) must be honored. Abstracting with credit is permitted. To copy otherwise, or republish, to post on servers or to redistribute to lists, requires prior specific permission and/or a fee. Request permissions from permissions@acm.org.

ISCA '22, June 18–22, 2022, New York, NY, USA

© 2022 Copyright held by the owner/author(s). Publication rights licensed to ACM.

ACM ISBN 978-1-4503-8610-4/22/06...\$15.00

<https://doi.org/10.1145/3470496.3527394>

ACM Reference Format:

Lingling Lao and Dan E. Browne. 2022. 2QAN: A quantum compiler for 2-local qubit Hamiltonian simulation algorithms. In *The 49th Annual International Symposium on Computer Architecture (ISCA '22)*, June 18–22, 2022, New York, NY, USA. ACM, New York, NY, USA, 15 pages. <https://doi.org/10.1145/3470496.3527394>

1 INTRODUCTION

Near-term quantum computers have a small number of qubits (tens to thousands) and non-negligible gate errors, making it impractical to implement conventional quantum algorithms such as Shor's factoring algorithm [1] which requires millions of qubits for a fault-tolerant implementation [2]. Quantum simulation (or Hamiltonian simulation) as first proposed by Richard Feynman [3] may require fewer qubits and be one of the first practical applications of quantum computers. Quantum simulation has broad applications in understanding the behaviour of physical systems in areas such as condensed-matter physics [4], high-energy physics [5], cosmology [6], quantum chemistry [7], and quantum field theory [8] and has been demonstrated in different quantum technologies [9, 10] (see [11] for a detailed review). Additionally, quantum simulation has been used to design new algorithms for solving linear systems [12], semidefinite programs [13], quantum walks [14], etc. Its main challenge is to find an efficient circuit that asymptotically approximates the time evolution of a Hamiltonian. The product formula approach has a straightforward implementation [15–17] and good performance in practice [18, 19]. Given a Hamiltonian that is decomposed as a sum of Hermitian terms ($H = \sum_{j=1}^L h_j H_j$), the product formula approximates the exponential of this Hamiltonian as a product of exponentials of individual terms and each exponential can be efficiently realized by a quantum circuit.

This high-level circuit representation is typically hardware agnostic and needs to be decomposed into the instruction set supported by the underlying quantum hardware. In noisy intermediate-scale quantum (NISQ) computers [20], the universal instruction set is normally composed of arbitrary single-qubit rotations plus one or a few two-qubit gates (e.g., the SYC, CNOT, iSWAP gates from Google, IBM, Rigetti respectively in Figure 1). Furthermore, these quantum computers only allow two-qubit gates between specific qubit pairs, i.e., there is limited qubit connectivity. Compilation techniques are required to map circuit qubits onto hardware qubits and insert SWAP gates to move qubits into neighbouring positions, increasing circuit size in terms of gate count and circuit depth. Two-qubit gates have much higher error rates than single-qubit rotations and qubits have short coherence time [21]. Therefore, it is critical to minimize compilation overhead for high-fidelity circuit implementation.

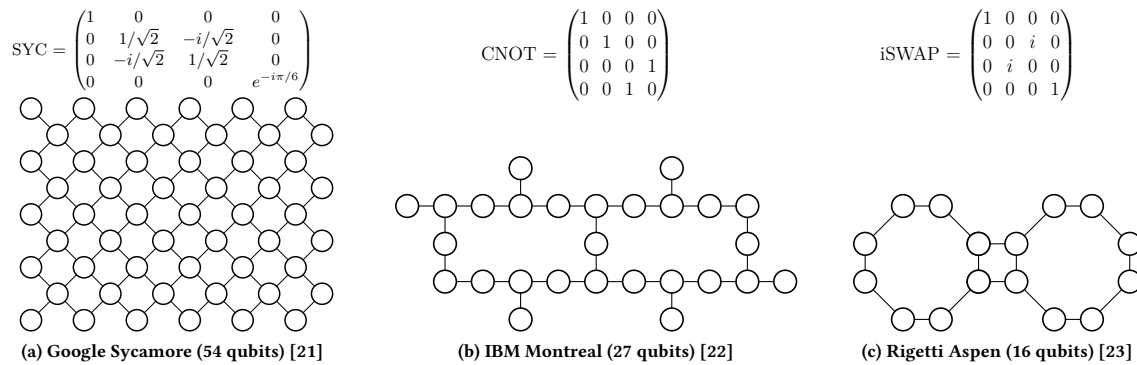

Figure 1: Device topologies and hardware two-qubit gates of different quantum computers. Nodes represent qubits and edges represent the connectivity between qubit pairs. All three devices allow arbitrary single-qubit rotations.

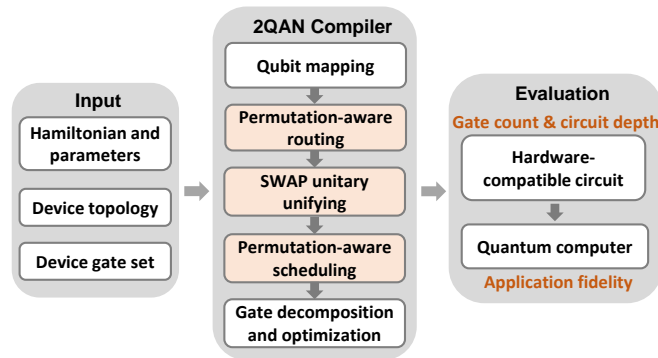

Figure 2: Overview of the 2QAN compiler. The highlighted compilation passes (Section 3) exploit the application-level semantics and cannot be replaced by general-purpose compilation techniques.

Many approaches have been proposed for compiling quantum circuits onto NISQ computers [24–31]. These compilers operate at the gate level and are designed for general circuits with little knowledge of the mathematical properties of the target applications. Exploiting the synergy between applications and compilation techniques can provide more optimizations of the implementation circuit, which will further improve application performance. For quantum simulation problems, the ordering of different terms in the Hamiltonian is arbitrary and one could permute the exponentials of these terms without losing computational accuracy. This is, however, difficult or even impossible for a compiler to recognize at gate level, especially when many of these operators do not commute with each other (changing the order of non-commuting gates violates program semantics). Several application-specific compilers have also been developed [32–40], but their optimization techniques are performed on one particular compilation pass and are limited to the CNOT or CZ gate set.

In this work, we identify the flexibility in the Hamiltonian operator permutation and exploit it in the compilation procedure. In particular, we propose permutation-aware qubit routing, gate

scheduling, and gate optimization techniques to efficiently compile circuits for 2-local qubit Hamiltonian simulation problems. The quantum approximate optimization algorithm (QAOA) [41] also has Hamiltonians in this form. The developed compiler, named 2QAN¹, can target different qubit architecture (topologies) and different gate sets. Evaluation results on three quantum computers show that 2QAN can significantly reduce gate count and circuit depth compared to state-of-the-art quantum compilers. Furthermore, we experimentally demonstrate the advantages of 2QAN on the IBMQ Montreal device. The evaluation toolflow is presented in Figure 2.

The main contributions of this work are:

- We discover an optimization opportunity for compiling quantum simulation problems on NISQ computers, i.e., the order of Hamiltonian terms is flexible and a quantum compiler can permute their exponentials (operators in the product formula) to minimize compilation overhead.
- We exploit this flexibility and develop 2QAN, a quantum compiler for efficiently compiling 2-local qubit Hamiltonian simulation problems on NISQ computers. We first propose a permutation-aware qubit routing heuristic to minimize the number of inserted SWAP gates. Then we implement a unitary unifying pass that combines a SWAP gate with a circuit gate to further reduce gate overhead. Moreover, we design a permutation-aware gate scheduling technique to minimize circuit depth. The routing and scheduling algorithms have quadratic time complexity in the number of gates and are scalable for large systems.
- We perform all the proposed permutation-aware compilation passes prior to the gate decomposition pass as shown in Figure 2. That is, these optimization algorithms are independent of the underlying hardware two-qubit gates, allowing 2QAN to target different instruction sets.
- We evaluate the proposed compiler by compiling the Heisenberg model, XY model, Ising model, and the QAOA circuits onto three industrial quantum computers, Google Sycamore [21], IBMQ Montreal [22], Rigetti Aspen [23]. Across all

¹Pronounced "toucan". We propose the name 2QAN since this compiler targets 2-local Qubit Hamiltonian simulation, is hardware Adapted and designed for NISQ quantum devices. <https://github.com/lllingoo/2QAN>

benchmarks and quantum computers, the 2QAN compiler outperforms state-of-the-art quantum compilers, including the general-purpose compilers t|ket> [30] and Qiskit [31], and the application-specific compilers, Paulihedral [40] and the QAOA compiler [36–38]. For example, 2QAN can reduce the SWAP count, two-qubit gate overhead, and depth overhead by on average 3.6x (9.1x), 4x (10.4x), and 2.1x (3.4x), respectively compared to t|ket> (Qiskit).

- We perform experiments for the QAOA benchmarks on the IBMQ Montreal device and demonstrate that the substantial compilation overhead reduction by using the 2QAN compiler provides a significant improvement in application performance. 2QAN achieves the highest fidelity for all problem sizes, and can increase the number of QAOA layers while the other compilers cannot.

2 BACKGROUND

2.1 Quantum simulation

Circuit construction: Consider a system Hamiltonian that is decomposed into a sum of polynomially many Hermitian terms, $H = \sum_{j=1}^L h_j H_j$, its time evolution can be described by the unitary $U(t) = \exp(itH)^2$. The goal is to find an efficient circuit construction for $U(t)$. It is hard to decompose this unitary directly when some terms anti-commute (which is typically the case in physical systems of interest), i.e., if $H_i H_j \neq H_j H_i$ then $\exp(itH) \neq \prod_{j=1}^L \exp(th_j H_j)$. Alternatively, one can use the *product formula* approach $[V(\Delta t)]^{\frac{t}{\Delta t}}$ to asymptotically approximate $\exp(itH)$ [15–17], where

$$V(\Delta t) = \prod_{j=1}^L \exp(i\Delta t h_j H_j). \quad (1)$$

$V(\Delta t)$ is called one *Trotterization step* in which each exponential operator $\exp(i\Delta t h_j H_j)$ can be more easily decomposed into a hardware gate set. $V(\Delta t)$ is repeated $\frac{t}{\Delta t}$ times to construct the entire circuit and choosing small Δt will suppress approximation errors.

Operator permutation: We note that the order of the L individual operators in each Trotter step (Equation 1) is arbitrary and can be chosen from any of the $L!$ permutations at the *application level* [42, 43]. This permutation flexibility allows one to perform optimized compilation for the Hamiltonian simulation circuit. In contrast, general-purpose quantum compilers assume a specific order and will not allow such rearrangement when operators do not commute.

Our work focuses on developing a permutation-aware compiler for optimizing each Trotter step, which will improve the overall circuit construction of quantum simulation since a large number ($\frac{t}{\Delta t}$) of such repetitions need to be performed. This compiler can also be applied to the QAOA benchmarks [41] and the problem-inspired variational quantum eigensolver (VQE) ansatz [44] which have similar circuit constructions to Equation 1 except that Δt is replaced by adjustable parameters. Other versatile VQE ansatzes

such as the hardware-efficient ansatz [45] need to be compiled by generic techniques.

2-local qubit Hamiltonian: In this work we consider 2-local qubit Hamiltonians that originate in many physical systems,

$$H = \sum_{(u,v) \in E} H_{uv} + \sum_{k \in V} H_k. \quad (2)$$

H_{uv} are two-qubit Hamiltonian terms and H_k are single-qubit Hamiltonians. The interaction graph of this Hamiltonian is represented by $G(V, E)$, V is the set of qubits and E is the set of edges. The transverse Ising model, XY model, and Heisenberg model all have Hamiltonians in this form,

$$H_{\text{Ising}} = \sum_{(u,v) \in E} \gamma_{uv} Z_u Z_v + \sum_{k \in V} \beta_k X_k, \quad (3)$$

$$H_{\text{XY}} = \sum_{(u,v) \in E} (\alpha_{uv} X_u X_v + \beta_{uv} Y_u Y_v), \quad (4)$$

$$H_{\text{Heisenberg}} = \sum_{(u,v) \in E} (\alpha_{uv} X_u X_v + \beta_{uv} Y_u Y_v + \gamma_{uv} Z_u Z_v), \quad (5)$$

where X, Y, Z are the Pauli operators. These are important models in the study of many-body physics and have been used for solving various problems. For example, the Heisenberg model is used to study magnetic systems in which the interacting particles have opposing spins [46]. The Ising model can be exploited for studying spontaneous magnetization in ferromagnetic film [47], neuroscience [48], and spin glasses [49]. The famous QAOA for solving combinatorial optimization problems also has the Ising model Hamiltonian [41].

2.2 Circuit compilation

NISQ computers have hardware limitations such as their native gate set and qubit connectivity, making general quantum circuits not directly executable. A hardware gate set is typically composed of arbitrary single-qubit rotations and a few two-qubit gates which vary across QC vendors. For example, IBM devices currently have the CNOT as the native two-qubit gate [22], Rigetti implement both CZ and iSWAP gates [23, 50], and Google support CZ, SYC, $\sqrt{\text{iSWAP}}$ gates [21, 51]. High-level quantum circuits need to be decomposed into the given gate set by using analytical algorithms [52, 53] or numerical approaches [54, 55]. Furthermore, two-qubit gates can only be executed on the connected (nearest neighbouring, NN) qubits. Movement operations such as SWAP gates need to be inserted for performing non-NN gates, increasing the number of gates and circuit depth. NISQ computers have limited qubit coherence time and high gate error rates. It is crucial to minimize circuit sizes for the reliable implementation of quantum applications. To this purpose, quantum compilation techniques, including qubit mapping and routing, gate decomposition and scheduling, have been developed to efficiently transform high-level quantum circuits into hardware-compatible ones. For general quantum circuits, the routing and scheduling algorithms assign dependencies between gates to maintain the correctness of the program semantics [24–31]. These dependencies are typically generated based on the gate order appearing in an input circuit. These general-purpose quantum compilers work at the gate level and do not consider application-level

²Strictly speaking, the evolution operator $U(t)$ representing the solution of the Schrödinger equation has the form $U(t) = \exp(-itH/\hbar)$. To simplify notation here, and without loss of generality, we set $\hbar = 1$ and consider negative time evolution $t \rightarrow -t$.

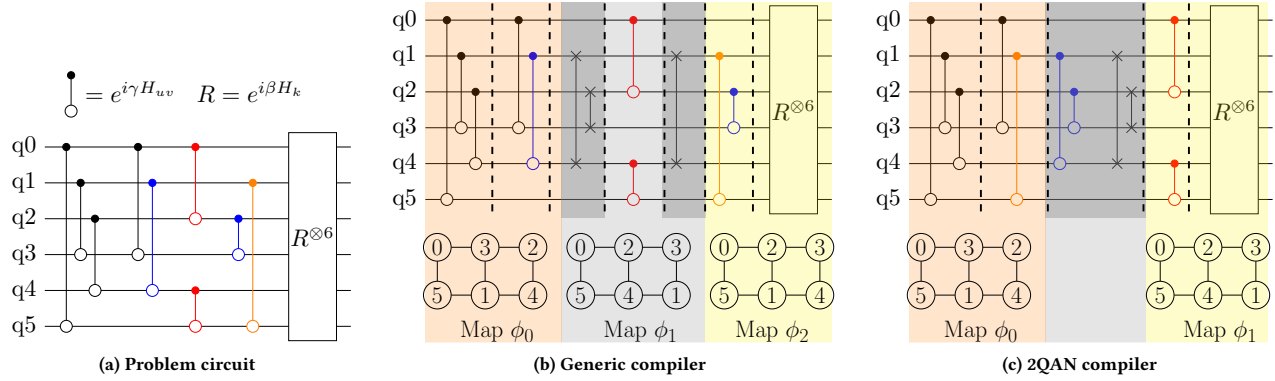

Figure 3: Examples of compiling a 6-qubit 2-local Hamiltonian (Equation 2) to a 2×3 grid architecture. (a) The circuit for one Trotter step, where the two(single)-qubit operators implement the evolution of two(single)-qubit Hamiltonians and two-qubit operators do not commute. (b-c) Compilation procedure. Top figures show the compiled circuits and bottom figures show the qubit mappings (nodes are qubits and edges represent their connectivity). Gates between dashed lines can be performed in parallel. Qubits in (b-c) always correspond to the circuit qubits in (a) for better readability. (b) A generic compiler respects the gate dependencies in (a). (c) The 2QAN compiler exploits the operator permutation flexibility and reduces the two-qubit gate count from 12 to 9 and the circuit depth from 7 to 5 (Each of inserted SWAPs is merged with a circuit unitary in gray area).

semantics. Any *application-specific* optimizations that can improve application performance are desirable for NISQ computing.

Compilation opportunities for Hamiltonian simulation: As mentioned previously, when constructing a circuit for each Trotter step, one is free to use any permutation of the operators in the product formula (even when they do not commute). This application-level property allows additional optimizations for Hamiltonian simulation problems but is not exploited by general-purpose quantum compilers. Figure 3 shows an example of compiling a 6-qubit Hamiltonian circuit to a 2×3 grid architecture. The compiler, considering the flexibility in operator permutation, places all the nearest-neighbor (NN) gates in the initial qubit map even though they are placed in later timesteps in the input circuit, avoiding unnecessary SWAP gates (e.g., the orange gate on q1 and q2 is moved to an earlier cycle in (c)). A generic compiler respects the gate dependency in the input circuit and cannot reorder non-commuting gates (e.g., the orange gate is scheduled in the last cycle in (b) and requires a SWAP gate for NN implementation). Furthermore, this permutation flexibility allows one to reschedule a circuit gate to the timestep of a SWAP gate acting on the same qubits (e.g., the blue gates are moved to the gray area in (c)) and then merge/unify these two gates into one gate, further decreasing gate count. In this work, we design such an application-specific compiler for 2-local qubit Hamiltonian simulation problems to improve application fidelity.

3 COMPILATION TECHNIQUES

In this section, we introduce the proposed compilation techniques underlying 2QAN. Figure 2 shows the overview of our 2QAN compiler.

3.1 Qubit mapping

The goal of qubit mapping is to find an optimal qubit initial placement such that the number of qubit-moving operations required

for implementing all two-qubit gates is minimized. Similar to the approaches in [56–58], the qubit mapping problem is formulated as a quadratic assignment problem (QAP). That is, the problem of allocating each qubit in the circuit (facility) to one qubit in the device (location) with the cost defined by a function of the distance and interaction times (flow) between circuit qubits. Let n be the number of circuit qubits or physical qubits and $N = \{1, 2, \dots, n\}$ denotes the qubit set. The objective function is

$$\min_{\phi \in S_n} \sum_{i=1}^n \sum_{j=1}^n f_{ij} d_{\phi(i)\phi(j)} \quad (6)$$

where S_n is the set of all permutations $\phi: N \rightarrow N$, f_{ij} is the number of two-qubit gates between circuit qubits i and j , $d_{\phi(i)\phi(j)}$ is the distance between hardware qubits $\phi(i)$ and $\phi(j)$ and is calculated by using the Floyd-Warshall algorithm.

QAP is an NP-hard problem [59] and we use the Tabu search heuristic algorithm [60, 61] to efficiently find good qubit mappings in this work. Other heuristics such as simulated annealing [62] and a greedy randomized adaptive search [63] can be also used for solving this problem. Prior works observed that the QAP formulation of qubit mapping may not work well for general quantum circuits [56–58]. This is because qubits need to interact in a specific order (gate dependency) and the initial mapping benefits diminish after insertion of SWAPs, e.g., some NN qubits may be moved further apart but will interact later (see the orange gate in Figure 3(b)). This is not the case for 2-local Hamiltonian simulation problems as any operator that is NN in a qubit map can be scheduled directly regardless of their order in the circuit (see the orange gate in Figure 3(c)). Thus, at this stage, we are already exploiting the permutation flexibility of this application.

3.2 Qubit routing

Generally, not all two-qubit gates are nearest neighbouring in an initial qubit map. Operations such as SWAP gates need to be inserted to move non-NN qubits, causing overheads in gate count and circuit depth. Efficient qubit routing techniques are required to minimize the compilation overhead. Different from existing qubit routing algorithms which respect the gate order in the input circuit [25, 28, 64, 65], the routing in 2QAN exploits the operator permutation flexibility in a Hamiltonian. The pseudocode is in Algorithm 1 (permutation-aware steps are highlighted with *) and an example is shown in Figure 3c.

Given an input circuit that implements one Trotter step of a Hamiltonian, our routing algorithm starts by searching all the two-qubit gates that are NN in an initial qubit layout (e.g., there are 7 NN two-qubit gates in Figure 3c). These gates are directly mapped no matter which timesteps they are scheduled in in the initial circuit (permutation flexibility). SWAP gates are needed to perform the remaining two-qubit gates (Lines 2-3), e.g., red gates on (q0, q3) and (q4, q5) in Figure 3c. For these non-NN gates, 2QAN compares their qubit distances in the hardware (Equation 6) and selects the shortest-distance one to route first (Line 5). If there are multiple shortest ones, it selects the first one in this set. Then the routing algorithm finds all possible SWAP gates that act on one of the qubits of the chosen gate g (Line 6). It evaluates these SWAPs based on a SWAP selection criteria (will be explained shortly) and selects the best one and adds it to the circuit (Line 7). This new SWAP gate updates the qubit map and NN gates are found for this map and are removed from the un-routed gate set (Lines 8-10). This procedure (Lines 5-10) is repeated until all two-qubit gates have been performed. The time complexity of the routing algorithm is $O(m^2n)$, m is the number of two-qubit gates and n is the number of qubits.

Algorithm 1 Permutation-aware routing

Input: Un-routed circuit, initial map ϕ_0 , device topology
Output: Routed circuit, a set of qubit maps $\{\phi_i\}$ and a set of NN gates corresponding to each map $\{G_{\phi_i}\}$

- 1: Initialize the set of qubit maps $\Phi = \{\phi_0\}$
- 2: *Initialize the set of NN gates for each map, $G = \{G_{\phi_0}\}, G_{\phi_0} \leftarrow$ all NN two-qubit gates for map ϕ_0
- 3: Initialize $G_{ur} \leftarrow$ all un-routed (non-NN) two-qubit gates
- 4: **while** $G_{ur} \neq \emptyset$ **do**
- 5: *Select the gate $g \in G_{ur}$ that has shortest distance in ϕ_i
- 6: $S_g \leftarrow$ Find all SWAP gates on qubits in g
- 7: *Select the best SWAP from S_g and add it to G_{ϕ_i}
- 8: Update qubit map from ϕ_i to ϕ_{i+1}
- 9: * $G_{\phi_{i+1}} \leftarrow$ Find NN gates in G_{ur} for map ϕ_{i+1}
- 10: *Remove all gates in $G_{\phi_{i+1}}$ from G_{ur} , add $G_{\phi_{i+1}}$ to G , add ϕ_{i+1} to Φ
- 11: **end while**

SWAP selection criteria: The best SWAP gate is chosen based on three criteria:

- (1) *Least SWAP count:* It will lead to the minimal cost in Equation 6 (i.e., the minimal number of SWAP gates) for the remaining non-NN gates.

- (2) *Shortest circuit depth:* It can be most interleaved with previously mapped gates, introducing the least depth overhead.
- (3) *Best gate optimization:* It can be merged with a circuit gate, i.e., if there is a circuit gate applied on the same qubits as this SWAP, the compiler will replace these two gates by a single unitary representing their product (more details will be introduced in the next section).

For our compiler configuration, we will evaluate the best SWAP based on the three criteria in the above priority order. Evaluating these criteria in a different order may further improve the compiler but will not be explored here. When there are multiple best options, a random one will be chosen. For example, both SWAP (0,3) and SWAP (2,3) in map ϕ_0 of Figure 3c can be added for performing the two-qubit gate on pair (0,2) and they have the same cost regarding the first two criteria. SWAP (2,3) is selected because it can be combined with a circuit gate that operate on the same qubits. For implementing the circuit gate on (4,5), both SWAP (1,5) and SWAP (1,4) are the best, and the compiler randomly selects one.

3.3 Unitary unifying

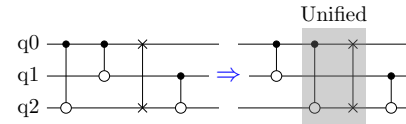

Figure 4: Unitary unifying example. The flexible operator permutation allows the circuit gate on qubits (0,2) to be rescheduled and combined with the SWAP gate.

SWAP unitary unifying: For each added SWAP gate, the compiler searches over all circuit gates. If there is a circuit gate operating on the same qubit pair as this SWAP, the compiler reschedules the circuit gate to the SWAP gate cycle and unifies them into a single unitary (see the example in Figure 4). Such rescheduling is allowed because of the operator permutation flexibility in Hamiltonian simulation. The unified unitary (referred as a *dressed SWAP*) is the product of the circuit gate unitary and the SWAP unitary. This unitary unifying helps further reduce the compilation overhead. Figure 5 shows the decomposition of a SWAP gate, a circuit gate $\exp(i\theta ZZ)$, and their unified unitary into CNOT gates and single-qubit rotations. The unified unitary requires 3 CNOTs while the implementation of these two gates with individual decompositions (in the left circuit in Figure 4) would require 5 CNOTs in total.

Circuit unitary unifying: Similarly, we merge all circuit gates that act on the same qubit pair into one single unitary. For example, there are three two-qubit Pauli terms on one qubit pair in the Heisenberg model (Equation 5). The exponential of a two-qubit Pauli operator normally requires 2 CNOTs. Implementing each of these three exponentials individually would use 6 CNOTs in total and compilation based on this implementation (e.g. as used in the Paulihedral compiler [40]) may be sub-optimal. In contrast, the unified unitary only requires 3 CNOTs since any two-qubit gate can be implemented by at most 3 CNOTs [66, 67]. To reduce gate count, we preprocess all 2-local Hamiltonian simulation circuits

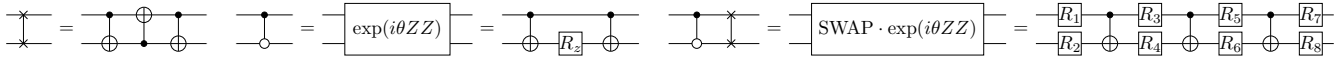

Figure 5: Examples of decomposing the SWAP, the unitary $\exp(i\theta ZZ)$, and their product into CNOTs and single-qubit rotations.

using circuit unitary unifying prior to other compilation passes (not shown in Figure 2).

3.4 Gate scheduling

Scheduling without dependency: When connectivity limitations are not considered, the individual operators in one Trotter step (Equation 1) can be performed in any order. Graph coloring algorithms [68] can be used to schedule such circuits. In the graph construction, nodes represent operators (gates), and two nodes are connected by an edge if they have common qubits and cannot be scheduled in parallel. We use the default greedy algorithm in NetworkX version 2.5 for our scheduling pass. The circuits without taking into account topology constraints are scheduled by this method and are baseline circuits used for calculating compilation overhead.

Scheduling with dependency: For connectivity-constrained quantum computers, the routing pass in previous section will be applied. The router outputs a list of qubit maps and a set of NN gates corresponding to each map, including both circuit gates and (dressed) SWAP gates. The order of a (dressed) SWAP gate and a circuit gate cannot be exchanged if the SWAP is inserted to make the circuit gate NN. One can generate a gate dependency graph based on the gate order after qubit routing and apply conventional scheduling algorithms [25, 26] to minimize circuit depth. This approach may perform sufficiently well for some circuits such as the one in Figure 3c, but more optimizations can be achieved for other circuits by considering the operator permutation in Hamiltonian simulation. In this work, we apply such application-specific optimizations and the pseudocode of the proposed gate scheduling algorithm is presented in Algorithm 2 (permutation-aware steps are highlighted with *) and an example is shown in Figure 6.

Hybrid scheduling: Algorithm 2 is a hybrid of the above two scheduling techniques. The flexible operator permutation property implies that circuit gates can be scheduled in any qubit map where they are NN. The NN circuit gates in the initial qubit map do not have dependencies and are first scheduled using the graph coloring algorithm (Line 1). For other qubit maps, dependencies between SWAP and circuit gates need to be respected. The algorithm initializes at the circuit cycle $t = 0$. We implement an as-late-as-possible (ALAP) schedule so the algorithm assigns the final qubit map to cycle 0 (M_0 , Line 2). For cycle t , it first finds all circuit gates that can be scheduled (Lines 6-8). A circuit gate can be scheduled at t only if its qubits are NN in map M_t and these qubits are not currently occupied by any other gates. For example, the gate on (1,3) in Figure 6b is scheduled at cycle 0 while it needs to be scheduled at a different cycle in Figure 6a because of the dependency constraint when using a generic scheduler (which cannot schedule it until its predecessor gate on (1,5) is performed). Afterwards, the scheduler finds all SWAP gates that can be scheduled at this cycle (Lines 9-12). Except the qubit NN and availability requirements, a SWAP gate can be scheduled at t only if the circuit gates that depends on it have

Algorithm 2 Permutation-aware scheduling

Input: The set of maps $\Phi = \{\phi_i\}$ and the set of NN gates corresponding to each map $G = \{G_{\phi_i}\}$
Output: Scheduled circuit

- 1: *Use graph coloring algorithm to schedule gates in G_{ϕ_0}
- 2: Initialize scheduling cycle $t = 0$ and the set of scheduled gates in this cycle $C_t = \emptyset$
- 3: Initialize qubit map for cycle t : $M_t \leftarrow$ last map in Φ (for an ALAP scheduling)
- 4: $G_{us} \leftarrow$ All un-scheduled gates $\in G$
- 5: **while** $G_{us} \neq \emptyset$ **do**
- 6: **for** each circuit gate $g \in G_{us}$ **do**
- 7: *Schedule g in C_t iff it is NN in M_t and its qubits are free
- 8: **end for**
- 9: **for** each SWAP gate $\in G_{us}$ **do**
- 10: Schedule it in C_t iff it is NN in M_t , its qubits are free, and there is no dependency violation
- 11: $M_{t+1} \leftarrow$ the map after applying this SWAP on M_t
- 12: **end for**
- 13: $t \leftarrow t + 1$ and update G_{us}
- 14: **end while**
- 15: Reverse the gate sequence in $\{C_0, \dots, C_t\}$ (ALAP)

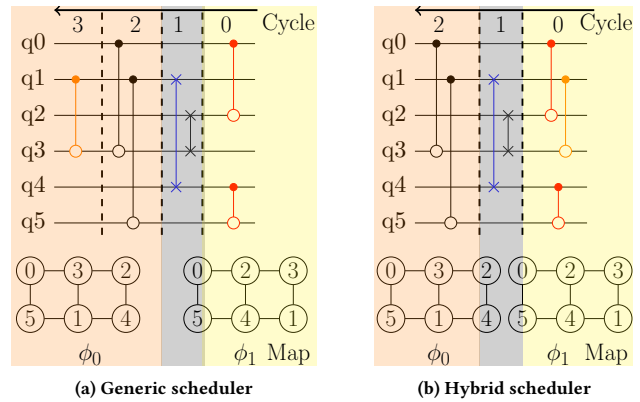

Figure 6: ALAP scheduling examples. (a) A generic scheduler respects the gate order provided by the routing pass (takes 4 cycles). (b) The hybrid scheduler considers the flexibility of permuting circuit gates and respects the dependency between a SWAP gate and its corresponding circuit gates (takes 3 cycles). For example, it schedules gate on pair (1,3) at cycle 0 because it is a NN circuit gate in map ϕ_1 while a generic scheduler will not schedule it until its predecessor (gate on (1,5)) is performed.

been scheduled (e.g., red gates depend on the two SWAPs in Figure 6b). Once a SWAP is inserted, the qubit map for next cycle will be updated. The procedure in Lines 6-13 is repeated until all gates are scheduled. Finally, the algorithm reverses the scheduled gate sequence (Line 15). The time complexity of this hybrid scheduling algorithm scales quadratically with the number of gates.

All the permutation-aware compiler passes do not depend on the native hardware gates and are performed prior to the gate decomposition procedure (Figure 2), providing the flexibility that 2QAN can target different instruction sets. Other application-specific compilers such as the QAOA compiler [36–38] and the Paulihedral compiler [40] are restricted to the CNOT/CZ gate set and lack optimizations in the routing and unitary unifying procedure.

4 EXPERIMENTAL SETUP

Benchmarks: We consider Hamiltonians of a linear array of qubits with nearest neighbouring (NN) and next nearest neighbouring (NNN) interactions for the transverse Ising model, XY model, and Heisenberg model. They are denoted **NNN Ising**, **NNN XY**, and **NNN Heisenberg**. The time evolution of a Hamiltonian is implemented using the product formula $(\prod_{j=1}^L \exp(ih_j H_{jt}/r))^r$, where r is the number of Trotter steps. The coefficients of H_j are randomly sampled from $(0, \pi)$. The number of two-qubit operators for NNN Ising, NNN XY, and NNN Heisenberg models in each Trotter step is $2n - 3$, where n is the number of qubits ranging from 6 to 50 in our evaluation.

In addition, we also use QAOA [41] for solving the MAX-CUT problems on 3-regular graphs (**QAOA-REG-3**) as our benchmark. QAOA is a popular benchmark for testing the performance of quantum computers and has been demonstrated in different quantum processors [69, 70]. In particular, the connectivity differs for each problem graph, which is well suited for evaluating compilation techniques. QAOA has the same form as the Ising model, its problem Hamiltonian is $C = \sum_{(u,v) \in E} Z_u Z_v$ and drive Hamiltonian is $B = \sum_{k \in V} X_k$. The circuit implementation of one-layer QAOA is

$$U(\gamma, \beta) = \prod_{(u,v) \in E} \exp(i\gamma Z_u Z_v) \prod_{k \in V} \exp(i\beta X_k), \quad (7)$$

Different from Hamiltonian simulation, these parameters (γ, β) differ in every layer. We randomly sample 10 graph instances for each problem size. The operator parameters for each instance are chosen at their theoretically optimal values and are calculated using the tools provided in ReCirq [71]. The number of two-qubit operators in one-layer of QAOA-REG-3 is $3n/2$, we consider qubit numbers n from 4 to 22.

Quantum computers: We compile these benchmarks onto three quantum computers, **Google Sycamore** [21], **IBMQ Montreal** [22], **Rigetti Aspen** [23]. As shown in Figure 1, Sycamore has a grid architecture with SYC as hardware two-qubit gate, Montreal has a dodecagon lattice with CNOT as native gate, Aspen has connected octagons and iSWAP as native gate. All three devices support arbitrary single-qubit rotations. Experiments on Montreal were performed on 29th October, 2021, the average CNOT error rate was 1.241%, average read-out error rate was 1.832%, and average $T_1=87.75 \text{ us}$ and $T_2=72.65 \text{ us}$.

Quantum compilers: We first compare our 2QAN compiler with two state-of-the-art general-purpose compilers, the **t|ket** compiler

version 0.11.0 with the recommended ‘FullPass’ [30] and the **Qiskit** compiler version 0.26.2 with optimization level 3 [31]. We then compare 2QAN with two application-specific compilers, the **QAOA compiler** (IC-QAOA) with default settings [36–38] and the **Paulihedral** compiler for quantum simulation [40]. For circuits with larger number of qubits, the default mapping in t|ket) may fail to find a qubit initial placement and we use their ‘LinePlacement’ pass instead. t|ket) and Qiskit have advanced circuit optimizations for the CNOT or CZ gates. For devices that have different hardware two-qubit gates, we disable the gate decomposition pass in Qiskit and t|ket). The 2QAN compiler always performs permutation-aware passes prior to gate decomposition. The mapped circuits that have application-level unitaries will need to be decomposed into hardware gate sets. We apply the ‘SynthesiseIBM’ decomposition pass in t|ket) to decompose the mapped circuits by 2QAN for the Montreal device. We use the analytical method in Cirq [72] to decompose QAOA and Ising unitaries into SYC gates. For other application unitaries and hardware gates, we use the numerical approach developed in [55] for finding more efficient decomposition. Both Qiskit and 2QAN involve randomization in the mapping procedure, we run their mapping passes 5 times and choose the best results. We also pre-process the input circuits for t|ket) and Qiskit by applying the circuit unitary unifying in Section 3.3 to reduce compilation overhead.

Metrics: Similar to prior works, we use the **number of inserted SWAP gates** (smaller is better), the **number of hardware two-qubit gates** (smaller is better), the **depth of two-qubit gates** (shorter is better), and the **depth of all gates** (shorter is better) as metrics to compare the performance of different compilers. We also calculate the increase in gate count and circuit depth (i.e., **compilation overhead**, less is better) compared to the circuits without considering connectivity constraints (i.e., the baseline implementation). Furthermore, we experimentally evaluate the application performance of QAOA benchmarks on the Montreal device. The performance is measured by the **normalized cost function** $\langle C \rangle / C_{\min}$ (larger is better) [70]. 1 means the perfect result and 0 corresponds to the random guessing result.

Implementation: We implement 2QAN in Python 3.8. All compilation in our evaluation was performed on a laptop with an Intel Core i7 processor (2.30GHz and 32GB RAM).

5 COMPILER EVALUATION

5.1 Reducing compilation overhead compared to general-purpose compilers

In this section, we compare the compilation overhead of our 2QAN compiler with t|ket) and Qiskit. Figures 7, 8, 9 show the compilation results on Google Sycamore, Rigetti Aspen, and IBM Montreal, respectively. Compared to t|ket) and Qiskit, 2QAN has least compilation overhead in terms of the number of inserted SWAP gates, the number of hardware two-qubit gates, and the circuit depth. We summarize the overhead reduction of 2QAN versus t|ket) and Qiskit in Tables 1 and 2 respectively. We define the overhead reduction as the ratio of the overhead of t|ket) or Qiskit and the overhead of 2QAN.

Across all benchmarks and quantum computers, 2QAN inserts on average 3.6x fewer SWAPs than t|ket) and 9.1x fewer SWAPs

Benchmark	Sycamore						Aspen						Montreal					
	SWAPs		SYCs		SYC Depth		SWAPs		iSWAPs		iSWAP Depth		SWAPs		CNOTs		CNOT Depth	
	avg	max	avg	max	avg	max	avg	max	avg	max	avg	max	avg	max	avg	max	avg	max
NNN Heisenberg	1.7x	3.9x	–	–	1.2x	2.7x	1.1x	1.8x	3.2x	5x	1.5x	3.2x	2.2x	4.6x	6x	12.8x	2.4x	5.2x
NNN XY	1.7x	3.4x	6.2x	21.1x	1.2x	2.1x	1.1x	1.7x	1.9x	3.8x	1.3x	2.5x	2.8x	4.5x	5.3x	8.3x	2.7x	3.9x
NNN Ising	1.9x	3.9x	5.6x	10.7x	1.3x	2.9x	1.1x	1.8x	2x	3.2x	1.5x	3.4x	2.7x	4.1x	4.9x	7.8x	2.7x	4x
QAOA-REG-3	1.8x	2.5x	3.2x	4.4x	3.9x	9.5x	1.8x	2.4x	3x	4.5x	2.2x	3.8x	2x	2.4x	3x	4.3x	3x	4x

Table 1: The average (avg) and maximum (max) compilation overhead reduction when comparing 2QAN with t|ket⟩ [30]. For the cases with blank values ‘–’, the 2QAN compiler has negligible overhead.

Benchmark	Sycamore						Aspen						Montreal					
	SWAPs		SYCs		SYC Depth		SWAPs		iSWAPs		iSWAP Depth		SWAPs		CNOTs		CNOT Depth	
	avg	max	avg	max	avg	max	avg	max	avg	max	avg	max	avg	max	avg	max	avg	max
NNN Heisenberg	6x	9.7x	–	–	1.8x	2.6x	3.3x	4.3x	9.3x	13x	2.7x	3.4x	5.1x	10.1x	14x	27.8x	3.8x	7.6x
NNN XY	6.5x	11.1x	24.1x	68.5x	2.1x	3.5x	3.2x	4.1x	5.4x	8.4x	2.5x	3.4x	5.6x	8.3x	10.7x	16.1x	4x	6x
NNN Ising	6.7x	11.5x	19x	30.7x	2.4x	4.1x	3.3x	4.1x	5.6x	7.4x	3x	3.9x	5.3x	8.2x	9.7x	15x	4x	7.4x
QAOA-REG-3	4.7x	6.4x	8x	10.6x	6.9x	21x	3.1x	4x	5.2x	6.9x	3.5x	5x	3x	3.9x	4.4x	5.1x	3.7x	4.8x

Table 2: The average (avg) and maximum (max) compilation overhead reduction when comparing 2QAN with Qiskit [31]. For the cases with blank values ‘–’, the 2QAN compiler almost has negligible overhead.

Benchmark	Paulihedral		2QAN	
	CNOTs	Depth	CNOTs	Depth
Heisenberg-1D (30 qubits)	87	13	87	13
Heisenberg-2D (30 qubits)	216	43	147	25
Heisenberg-3D (30 qubits)	305	65	177	31
QAOA-REG-4 (20 qubits)	366	147	177(7)	71(4)
QAOA-REG-8 (20 qubits)	539	246	324(9)	160(16)
QAOA-REG-12 (20 qubits)	678	319	419(9)	222(22)

Table 3: Comparison with Paulihedral [40]. The numbers in brackets show the standard deviation over 10 instances.

than Qiskit. This SWAP count reduction will lead to a significant reduction in the hardware two-qubit gate count. Moreover, a large percent of SWAPs are unified with circuit gates by the unitary unifying pass in 2QAN (gray bars in (a), (d), (g) of Figures 7-9), further reducing the gate count. For example, when compiling to Sycamore, 2QAN almost has *no SYC overhead* compared to the baseline ‘NoMap’ for the Heisenberg model. This is because most of the SWAPs can be combined with circuit gates (Figure 7a) and such an unified gate can be decomposed into a similar number of SYCs as a circuit gate $\exp(it(\alpha XX + \beta YY + \gamma ZZ))$. In contrast, t|ket⟩ and Qiskit have on average 24.5% and 92.3% SYC overhead. 2QAN reduces the two-qubit gate overhead by 4x and 10.4x compared to t|ket⟩ and Qiskit on average over all benchmarks. This gate count reduction helps reduce the circuit depth. The average depth overhead reduction achieved by 2QAN is 2.1x and 3.4x relative to t|ket⟩ and Qiskit.

5.2 Reducing compilation overhead compared to application-specific compilers

We further compare 2QAN with the QAOA compiler in [36–38] and the Paulihedral compiler in [40]. We will only evaluate the

compilation results on IBM quantum computers because these two compilers are restricted to the CNOT or CZ gate set. Compared to the QAOA compiler, 2QAN reduces SWAP count, CNOT count overhead, and CNOT depth overhead by on average 2.6x, 4x, and 2.8x, respectively (Figure 9j-9l). The Paulihedral compiler is not open-sourced yet and we directly use the compilation results from [40] as shown in Table 3. The Heisenberg models were compiled by assuming all-to-all connectivity and the QAOA-REG-m were compiled to the IBMQ Manhattan device that has a dodecagon lattice and uses the CNOT as its native two-qubit gate. We generate 10 random graphs for each QAOA problem and present the average compilation results of 2QAN in Table 3. The CNOT count and circuit depth achieved by Paulihedral are on average 1.59x and 1.64x as high as the circuits compiled by 2QAN. Therefore, by employing the permutation-aware optimizations in the routing and unitary unifying passes, 2QAN outperforms both application-specific compilers in terms of compilation overhead.

5.3 Improving application performance

To study how the compilation overhead reduction impacts application performance, we experimentally implemented the QAOA benchmarks with different numbers of layers on the IBMQ Montreal device. For the multiple-layer QAOA circuits, the 2QAN compiler only performs compilation for the first layer and obtains a circuit c_1 . For odd number layers, it directly uses the compiled circuit structure in c_1 and assigns corresponding parameters for each gate. For even number layers, it simply reverses the two-qubit gate order in c_1 . In contrast, t|ket⟩ and Qiskit compile a multiple-layer QAOA circuit as a whole. For all four compilers, the compilation overhead of a n -layer QAOA circuit is approximately n times of the overhead of a single-layer circuit. In NISQ computers, the implementation of a quantum application that has fewer hardware gates (reducing gate errors) and shorter circuit depth (reducing decoherence

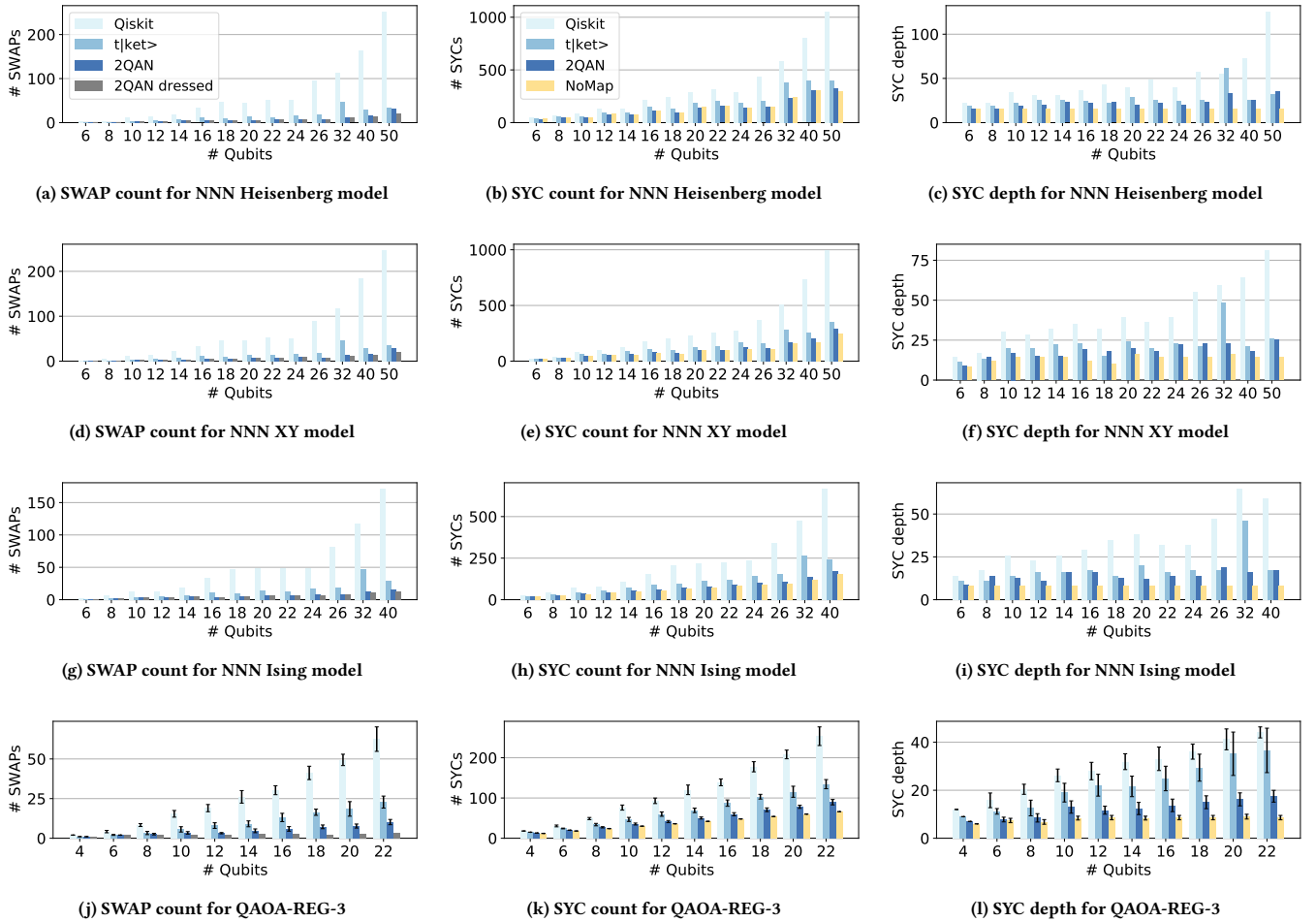

Figure 7: Compilation results of the one-layer NNN Heisenberg model, NNN XY, NNN Ising model, and QAOA-REG-3 on the Google Sycamore device. Each QAOA problem size is averaged over 10 different instances (error bars show the standard deviation) and operator parameters of QAOA circuits were chosen at their theoretically optimal values. ‘2QAN dressed’ shows the number of SWAPs that were merged with circuit gates by 2QAN, which helps to reduce hardware gate count. ‘NoMap’ as our baseline, represents the compilation results when assuming all-to-all qubit connectivity. The 2QAN compiler has least compilation overhead (# SWAPs, # SYCs, and circuit depth) compared to t|ket>[30] and Qiskit [31].

errors) should have better performance (higher fidelity). This is experimentally demonstrated in Figure 10, the circuits compiled by 2QAN have the *best application performance* compared to the results from using t|ket>, Qiskit, and IC-QAOA for all problem sizes and all numbers of QAOA layers.

For example, as noise accumulates in QAOA circuits they will often converge to the value 0 corresponding to a random guess. Here we see that the 3-layer QAOA benchmarks compiled by t|ket> or Qiskit or IC-QAOA already approach zero for problems with 8 qubits. In comparison, 2QAN only comes close to this value for much larger problems (around 20 qubits). Ideally (without hardware noise), the application performance should improve with the number of QAOA layers. However, in practice there is a trade off, with additional layers also increasing the overall error probabilities,

and hence decreasing application performance. Figure 10 shows that the QAOA performance for all problem sizes decreases when the number of layers increases for all compilers except the 4-qubit QAOA compiled by 2QAN of which performance improves when increasing the layer number from 1 to 2. This implies that efficient compilation techniques can enhance device capacity and potentially pave the way towards practical applications of quantum computing.

5.4 Scalability and runtime

We use the Tabu search algorithm for solving the qubit placement problem. This algorithm is fast for solving small problems, e.g. it takes around 1.6 seconds for the 10-qubit Ising model and 12.2 seconds for the 20-qubit QAOA. However, it becomes slow for larger

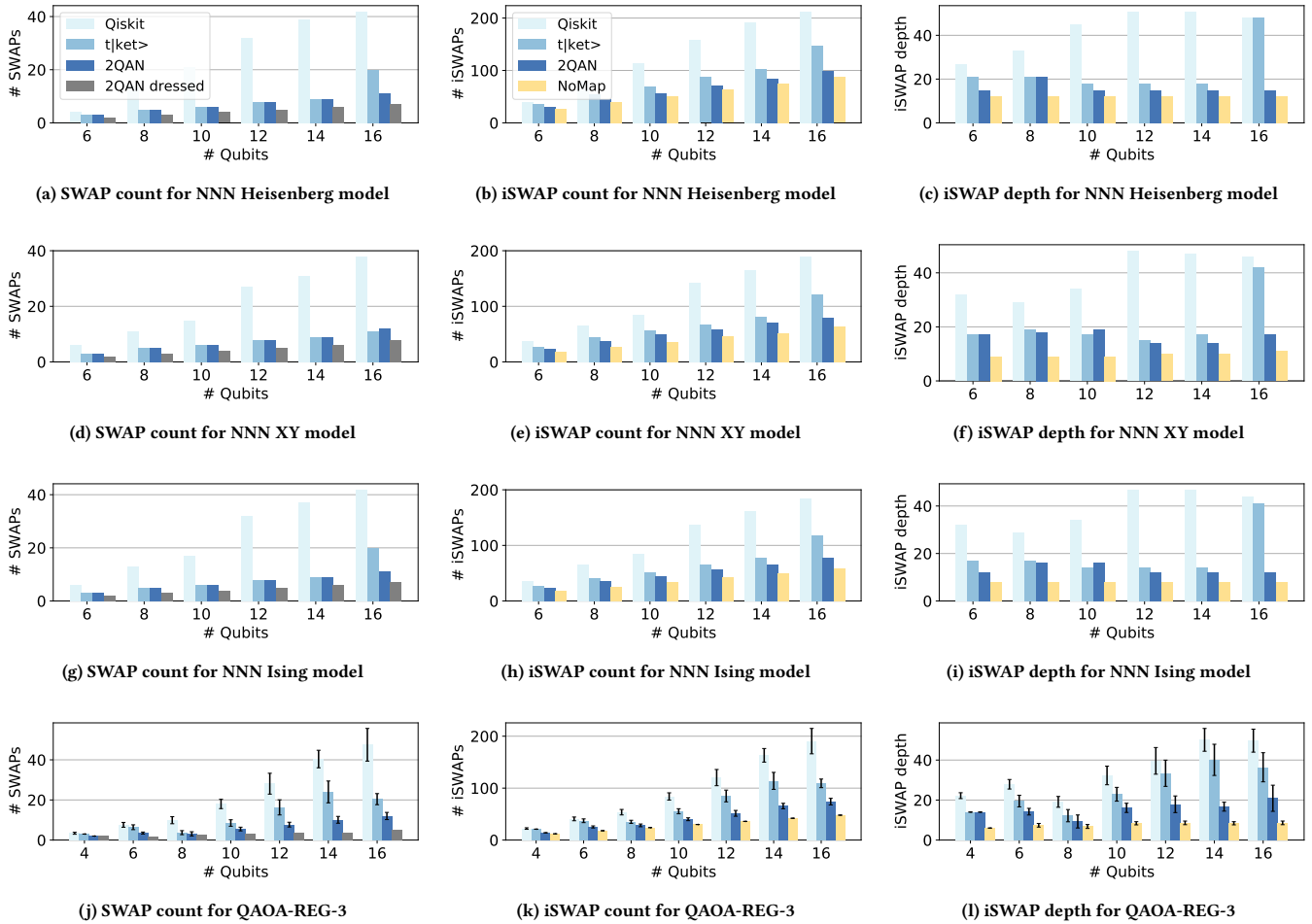

Figure 8: Compilation results of the one-layer NNN Heisenberg model, NNN XY, NNN Ising model, and QAOA-REG-3 on the Rigetti Aspen device. 2QAN has least compilation overhead (# SWAPs, # iSWAPs, and circuit depth) compared to t|ket> [30] and Qiskit [31].

problems and takes 330.2 (976.3) seconds for the 40(50)-qubit Heisenberg model. Qubit placement is not our main optimization goal in this work. More efficient algorithms exist for solving QAP problems [73] and other qubit mapping techniques [30, 31] could also be applied in future work. The proposed routing and scheduling heuristics (Algorithm 1 and Algorithm 2) scale at most quadratically with the number of gates in one Trotter step. For example, the compilation time including routing, unitary unifying, and scheduling for the 20(40)-qubit XY model in one Trotter step is around 0.007 (0.015) seconds. Moreover, we only perform the compilation for the first Trotter step and simply use this circuit for odd-number steps and reverse the two-qubit gate order for even-number steps. Such an implementation saves compilation time and is similar to the second-order Trotterization in [17]. This runtime evaluation and scalability analysis give us confidence that the 2QAN compiler will scale up to near-term quantum applications with a considerable number of qubits and gates.

6 RELATED WORK

The product formula is the most established approach to simulate the dynamics of quantum systems. Approximation errors arise when there are anti-commuting terms in the Hamiltonian. To achieve a desired precision, the time evolution is divided into many small time steps. Assume a simulation circuit has r Trotter steps and the operator count for implementing each step is G . Minimizing the circuit size Gr while maintaining computational accuracy is crucial for practical implementation. Besides the high-order approximation approach [17], many randomization approaches have been proposed to further reduce Gr [42, 43, 74–76]. Afterwards, these high-level circuits still need to be decomposed into native hardware gates. One popular approach for optimizing low-level circuits for Hamiltonian simulation is to first group Pauli terms into commuting sets and then apply simultaneous diagonalization of Pauli exponentials in each set [77, 78] or exploit gate cancellation between consecutive Pauli exponentials [79, 80]. Other works present circuit

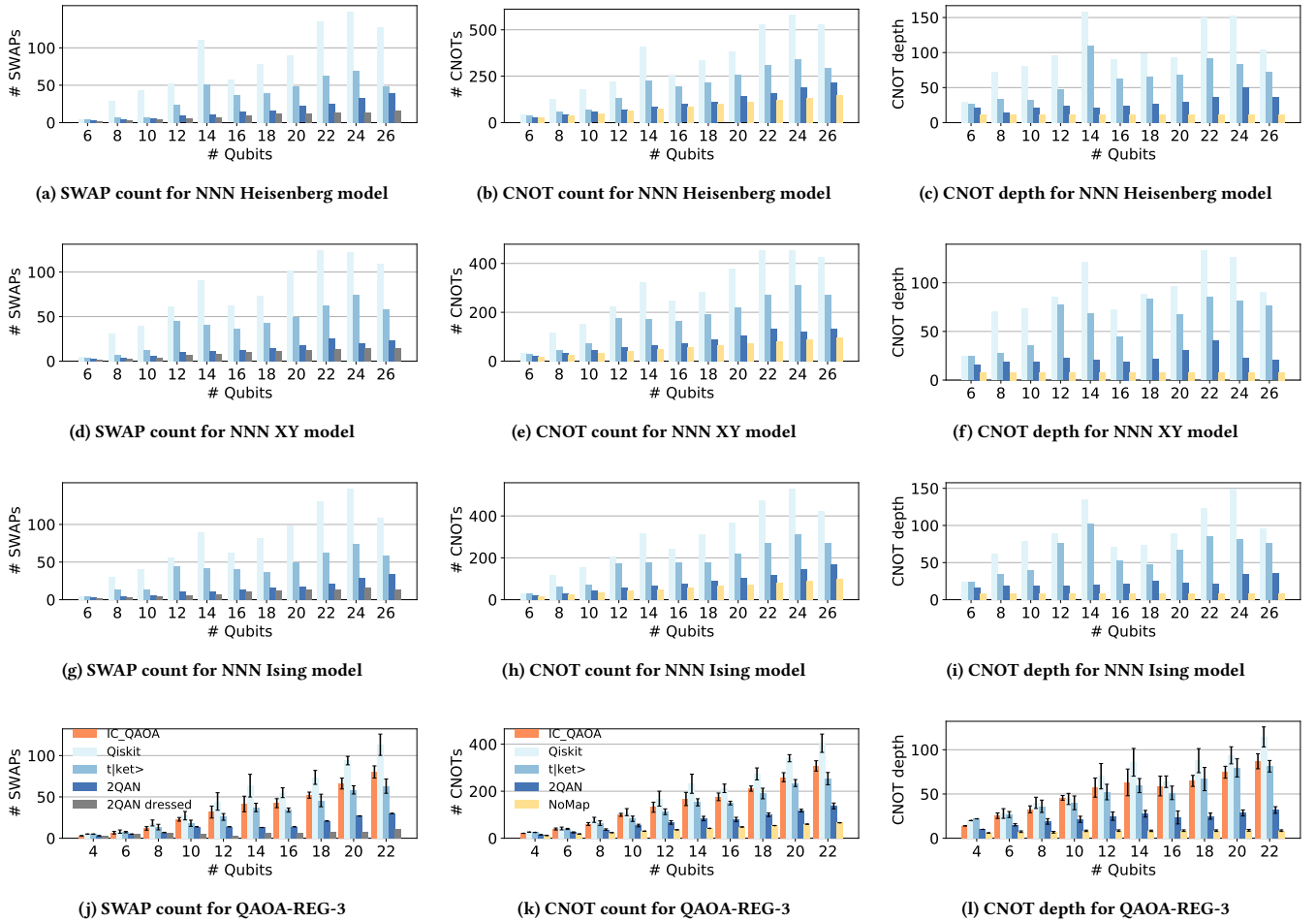

Figure 9: Compilation results of the one-layer NNN Heisenberg model, NNN XY, NNN Ising model, and QAOA-REG-3 on the IBMQ Montreal device. The 2QAN compiler has least compilation overhead (# SWAPs, # CNOTs, and circuit depth) compared to t|ket> [30], Qiskit [31], and the QAOA compiler (IC-QAOA) [36–38].

synthesis method based on the ZX-calculus [81, 82]. However, these low-level circuit optimization approaches are restricted to CNOT or CZ-based circuits and most of them do not consider the qubit connectivity constraint, requiring further compilation.

Many compilation techniques have been proposed to map quantum circuits onto NISQ computers with limited qubit connectivity and native gate sets. Some of them optimize gate count to reduce errors from two-qubit gates or minimize circuit depth to mitigate the effect of decoherence [24–27]. Others consider spatial and temporal noise variations and develop noise-aware compilation algorithms to minimize error rates [28, 29, 64, 83]. Industrial quantum compilers such as t|ket> [30] and Qiskit [31] incorporate multiple techniques to achieve the best application performance. These general-purpose compilers typically operate at the gate level and can work for general quantum applications. Nevertheless, they have little knowledge of the mathematical properties at the application level and therefore lack fine-grained optimizations.

Application-specific compilation techniques will be advantageous for NISQ computing. For example, optimized compilers have been developed for variational quantum algorithms [32–39] and quantum simulation with product formulas [40, 84]. The optimization techniques in most specialized compilers (such as IC-QAOA [36–38], Paulihedral [40]) are restricted to CNOT or CZ gates and are not applicable to (or cause higher overhead in) quantum computers with other hardware gates such as the SYC gate in Google Sycamore [21] and the iSWAP gate in Rigetti Aspen [23]. Furthermore, most of them do not exploit the flexible operator permutation property in the product formula approach to quantum simulation (no matter whether these operators commute or not). For instance, the compilers in [33–38] only check for commuting gates in the circuit mapping procedure but many terms in the Hamiltonian may not commute (e.g., the XY model and Heisenberg model) and changing the order of anti-commuting gates will be prohibited. The Paulihedral compiler in [40] considers this flexibility in the term scheduling

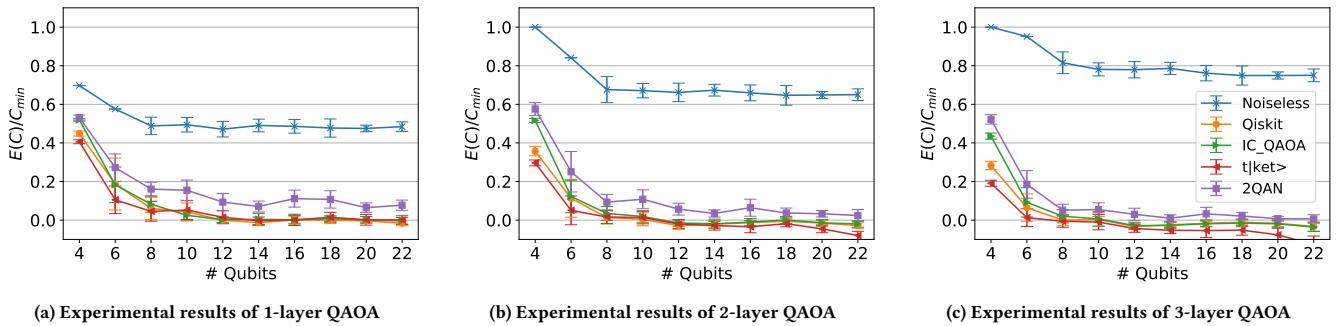

Figure 10: Experimental results of running QAOA-REG-3 on the IBMQ Montreal device. The y axis shows the application performance, which is measured by the normalized cost function $\langle C \rangle / C_{\min}$ (larger is better). Each problem size is averaged over 10 different instances (error bars show the standard deviation). The operator parameters of QAOA circuits were chosen at their theoretically optimal values. For the same layer QAOA, 2QAN always achieves better application performance compared to other compilers. The ideal costs increase with the number of QAOA layers (noiseless results in (a-c)). However, in experimental implementation increasing QAOA layers (increasing circuit sizes) increases the probabilities of hardware errors, which may decrease QAOA performance. The application performance of the 4-qubit QAOA compiled by 2QAN improves when the number of layers is increased from 1 to 2 while using the other compilers cannot.

procedure but lacks optimizations in qubit routing and unitary unifying. Our 2QAN compiler can target different architectures and provide efficient compilation for different gate sets.

7 CONCLUSIONS

We have developed an application-specific compiler for 2-local qubit Hamiltonian simulation problems. The 2QAN compiler exploits the flexibility of permuting operators in a Hamiltonian and performs optimizations on the qubit routing, gate synthesis, and gate scheduling passes. Evaluation results show that 2QAN can significantly reduce compilation overhead compared to two general-purpose compilers and two application-specific compilers across three quantum computers with different topologies and gate sets. For some applications, 2QAN even has no gate overhead. Furthermore, experimental results demonstrate that 2QAN can achieve the highest application fidelity in practice on hardware. We believe application-specific compilation techniques will help enhance the performance of quantum applications on NISQ devices and allow them to explore their maximum capacities.

Future work will perform more optimizations and investigate other research directions. First, the objective of 2QAN is to minimize the number of SWAP gates and circuit depth. NISQ computers have inhomogeneities and noise-aware compilation techniques can be used to maximize application fidelity [28, 29, 64, 83]. Moreover, error mitigation techniques can be applied to further reduce errors [85–88]. In the experimental results reported here, we only compiled the first Trotter step in Hamiltonian simulation and simply applied a reverse scheduling for the two-qubit gates in the even-number steps. Prior works prove that randomizing the operator order in each step can reduce the simulation costs [42, 43]. Future work can adapt 2QAN to this randomization and analyze how randomized compiling affects approximation errors and the efficiency of quantum simulation algorithms. In addition, it is worthwhile

to investigate how to generalize these compilation techniques for k -local Hamiltonians and other quantum simulation algorithms.

ACKNOWLEDGMENTS

We thank Prakash Murali for valuable feedback on the manuscript. We thank Silas Dilkes for help with the $t|ket\rangle$ compiler. We thank César A. Rodríguez Rosario for help with the experimental setup on the IBMQ Montreal device via Strangeworks QC platform. We acknowledge the use of the IBM Q platform for this work. We acknowledge funding from the EPSRC Prosperity Partnership in Quantum Software for Modelling and Simulation (Grant No. EP/S005021/1) and support from the Unitary Fund to open source the 2QAN compiler.

REFERENCES

- [1] P.W. Shor. Algorithms for quantum computation: discrete logarithms and factoring. In *Proceedings 35th Annual Symposium on Foundations of Computer Science*, pages 124–134, 1994.
- [2] Joe O’Gorman and Earl T. Campbell. Quantum computation with realistic magic-state factories. *Phys. Rev. A*, 95:032338, Mar 2017.
- [3] Richard P Feynman. Simulating physics with computers. *International Journal of Theoretical Physics*, 21(6/7), 1982.
- [4] D. Jaksch, C. Bruder, J. I. Cirac, C. W. Gardiner, and P. Zoller. Cold bosonic atoms in optical lattices. *Phys. Rev. Lett.*, 81:3108–3111, Oct 1998.
- [5] Tim Byrnes and Yoshihisa Yamamoto. Simulating lattice gauge theories on a quantum computer. *Phys. Rev. A*, 73:022328, Feb 2006.
- [6] P. D. Nation, M. P. Blencowe, A. J. Rimberg, and E. Buks. Analogue hawking radiation in a dc-squid array transmission line. *Phys. Rev. Lett.*, 103:087004, Aug 2009.
- [7] David Poulin, Matthew B Hastings, Dave Wecker, Nathan Wiebe, Andrew C Doherty, and Matthias Troyer. The Trotter step size required for accurate quantum simulation of quantum chemistry. *arXiv preprint arXiv:1406.4920*, 2014.
- [8] Stephen P Jordan, Keith SM Lee, and John Preskill. Quantum algorithms for quantum field theories. *Science*, 336(6085):1130–1133, 2012.
- [9] Cornelius Hempel, Christine Maier, Jonathan Romero, Jarrod McClean, Thomas Monz, Heng Shen, Petar Jurcevic, Ben P. Lanyon, Peter Love, Ryan Babbush, Alán Aspuru-Guzik, Rainer Blatt, and Christian F. Roos. Quantum chemistry calculations on a trapped-ion quantum simulator. *Phys. Rev. X*, 8:031022, Jul 2018.
- [10] Frank Arute, Kunal Arya, Ryan Babbush, Dave Bacon, Joseph C Bardin, Rami Barends, Andreas Bengtsson, Sergio Boixo, Michael Broughton, Bob B Buckley, David A Buell, Brian Burkett, Nicholas Bushnell, Yu Chen, Zijun Chen, Yu-An

- Chen, Ben Chiaro, Roberto Collins, Stephen J Cotton, William Courtney, Sean Demura, Alan Derk, Andrew Dunsworth, Daniel Eppens, Thomas Eckl, Catherine Erickson, Edward Farhi, Austin Fowler, Brooks Foxen, Craig Gidney, Marissa Giustina, Rob Graff, Jonathan A Gross, Steve Habegger, Matthew P Harrigan, Alan Ho, Sabrina Hong, Trent Huang, William Huggins, Lev B Ioffe, Sergei V Isakov, Evan Jeffrey, Zhang Jiang, Cody Jones, Dvir Kafri, Kostyantyn Kechedzhi, Julian Kelly, Seon Kim, Paul V Klimov, Alexander N Korotkov, Fedor Kostritsa, David Landhuis, Pavel Laptev, Mike Lindmark, Erik Lucero, Michael Marthaler, Orion Martin, John M Martinis, Anika Maruszczyk, Sam McArdle, Jarrod R McClean, Trevor McCourt, Matt McEwen, Anthony Megrant, Carlos Mejuto-Zaera, Xiao Mi, Masoud Mohseni, Wojciech Mruzekiewicz, Josh Mutus, Ofer Naaman, Matthew Neeley, Charles Neill, Hartmut Neven, Michael Newman, Murphy Yuezhen Niu, Thomas E O'Brien, Eric Ostby, Bálint Pató, Andre Petukhov, Harald Putterman, Chris Quintana, Jan-Michael Reiner, Pedram Roushan, Nicholas C Rubin, Daniel Sank, Kevin J Satzinger, Vadim Smelyanskiy, Doug Strain, Kevin J Sung, Peter Schmitteckert, Marco Szalay, Norm M Tubman, Amit Vainsencher, Theodore White, Nicolas Vogt, Z Jamie Yao, Ping Yeh, Adam Zalcman, and Sebastian Zanker. Observation of separated dynamics of charge and spin in the Fermi-Hubbard model. *arXiv preprint arXiv:2010.07965*, October 2020.
- [11] I. M. Georgescu, S. Ashhab, and Franco Nori. Quantum simulation. *Rev. Mod. Phys.*, 86:153–185, Mar 2014.
- [12] Aram W. Harrow, Avinandan Hassidim, and Seth Lloyd. Quantum algorithm for linear systems of equations. *Phys. Rev. Lett.*, 103:150502, Oct 2009.
- [13] Fernando GSL Brandao and Krysta M Svore. Quantum speed-ups for solving semidefinite programs. In *2017 IEEE 58th Annual Symposium on Foundations of Computer Science (FOCS)*, pages 415–426. IEEE, 2017.
- [14] Andrew M Childs, Richard Cleve, Enrico Deotto, Edward Farhi, Sam Gutmann, and Daniel A Spielman. Exponential algorithmic speedup by a quantum walk. In *Proceedings of the thirty-fifth annual ACM symposium on Theory of computing*, pages 59–68, 2003.
- [15] Hale F Trotter. On the product of semi-groups of operators. *Proceedings of the American Mathematical Society*, 10(4):545–551, 1959.
- [16] Seth Lloyd. Universal quantum simulators. *Science*, pages 1073–1078, 1996.
- [17] Masuo Suzuki. General theory of fractal path integrals with applications to many-body theories and statistical physics. *Journal of Mathematical Physics*, 32(2):400–407, 1991.
- [18] Ryan Babbush, Jarrod McClean, Dave Wecker, Alán Aspuru-Guzik, and Nathan Wiebe. Chemical basis of Trotter-Suzuki errors in quantum chemistry simulation. *Phys. Rev. A*, 91:022311, Feb 2015.
- [19] Andrew M Childs, Dmitri Maslov, Yunseong Nam, Neil J Ross, and Yuan Su. Toward the first quantum simulation with quantum speedup. *Proceedings of the National Academy of Sciences*, 115(38):9456–9461, 2018.
- [20] John Preskill. Quantum computing in the NISQ era and beyond. *Quantum*, 2:79, 2018.
- [21] Frank Arute, Kunal Arya, Ryan Babbush, Dave Bacon, Joseph C. Bardin, Rami Barends, Rupak Biswas, Sergio Boixo, Fernando G. S. L. Brandao, David A. Buell, Brian Burkett, Yu Chen, Zijun Chen, Ben Chiaro, Roberto Collins, William Courtney, Andrew Dunsworth, Edward Farhi, Brooks Foxen, Austin Fowler, Craig Gidney, Marissa Giustina, Rob Graff, Keith Guerin, Steve Habegger, Matthew P. Harrigan, Michael J. Hartmann, Alan Ho, Markus Hoffmann, Trent Huang, Travis S. Humble, Sergei V. Isakov, Evan Jeffrey, Zhang Jiang, Dvir Kafri, Kostyantyn Kechedzhi, Julian Kelly, Paul V. Klimov, Sergey Knysh, Alexander Korotkov, Fedor Kostritsa, David Landhuis, Mike Lindmark, Erik Lucero, Dmitry Lyakh, Salvatore Mandrà, Jarrod R. McClean, Matthew McEwen, Anthony Megrant, Xiao Mi, Kristel Michielsen, Masoud Mohseni, Josh Mutus, Ofer Naaman, Matthew Neeley, Charles Neill, Murphy Yuezhen Niu, Eric Ostby, Andre Petukhov, John C. Platt, Chris Quintana, Eleanor G. Rieffel, Pedram Roushan, Nicholas C. Rubin, Daniel Sank, Kevin J. Satzinger, Vadim Smelyanskiy, Kevin J. Sung, Matthew D. Trevithick, Amit Vainsencher, Benjamin Villalonga, Theodore White, Z. Jamie Yao, Ping Yeh, Adam Zalcman, Hartmut Neven, and John M. Martinis. Quantum supremacy using a programmable superconducting processor. *Nature*, 574(7779):505–510, 2019.
- [22] IBM. IBM Quantum Experience Devices. <https://quantum-computing.ibm.com/>, 2020.
- [23] Rigetti. Rigetti computing. <https://www.rigetti.com/>, 2020.
- [24] Alvin Zulehner, Alexandru Paler, and Robert Wille. An efficient methodology for mapping quantum circuits to the IBM QX architectures. *IEEE Transactions on Computer-Aided Design of Integrated Circuits and Systems*, 38(7):1226–1236, 2018.
- [25] Alexander Cowtan, Silas Dilkes, Ross Duncan, Alexandre Krajenbrink, Will Simmons, and Seyon Sivarajah. On the qubit routing problem. *arXiv preprint arXiv:1902.08091*, 2019.
- [26] Lingling Lao, Hans van Someren, Imran Ashraf, and Carmen G. Almudever. Timing and resource-aware mapping of quantum circuits to superconducting processors. *IEEE Transactions on Computer-Aided Design of Integrated Circuits and Systems*, pages 1–1, 2021.
- [27] Andrew M Childs, Eddie Schoute, and Cem M Unsal. Circuit transformations for quantum architectures. *arXiv preprint arXiv:1902.09102*, 2019.
- [28] Gushu Li, Yufei Ding, and Yuan Xie. Tackling the qubit mapping problem for NISQ-era quantum devices. In *Proceedings of the Twenty-Fourth International Conference on Architectural Support for Programming Languages and Operating Systems*, pages 1001–1014. ACM, 2019.
- [29] Prakash Murali, Jonathan M Baker, Ali Javadi-Abhari, Frederic T Chong, and Margaret Martonosi. Noise-Adaptive Compiler Mappings for Noisy Intermediate-Scale Quantum Computers. In *Proceedings of the Twenty-Fourth International Conference on Architectural Support for Programming Languages and Operating Systems*, pages 1015–1029, 2019.
- [30] Seyon Sivarajah, Silas Dilkes, Alexander Cowtan, Will Simmons, Alec Edgington, and Ross Duncan. $\text{t|ket}>$: a retargetable compiler for NISQ devices. *Quantum Science and Technology*, 6(1):014003, 2020.
- [31] Héctor Abraham, AduOffei, Rochisha Agarwal, Ismail Yunus Akhalwaya, Gadi Aleksandrowicz, Thomas Alexander, Eli Arbel, Abraham Asfaw, Carlos Azaustre, AzizNgoueya, Aman Bansal, Panagiotis Barkoutsos, George Barron, Luciano Bello, Yael Ben-Haim, Daniel Bevenius, Lev S. Bishop, Sorin Bolos, Samuel Bosch, Sergey Bravyi, David Bucher, Artemiy Burov, Fran Cabrera, Padraic Calpin, Lauren Capeluto, Jorge Carballo, Ginés Carrascal, Adrian Chen, Chen-Fu Chen, Edward Chen, Jielun (Chris) Chen, Richard Chen, Jerry M. Chow, Spencer Churchill, Christian Claus, Christian Clauss, Romilly Cocking, Abigail J. Cross, Andrew W. Cross, Simon Cross, Juan Cruz-Benito, Chris Culver, Antonio D. Córcoles-Gonzales, Sean Dague, Tareq El Dandachi, Marcus Daniels, Matthieu Dartiailh, Davide Ferr, Abdón Rodríguez Davila, Anton Dekusar, Delton Ding, Jun Doi, Eric Drechsler, Drew, Eugene Dumitrescu, Karel Dumon, Ivan Duran, Kareem EL-Safty, Eric Eastman, Pieter Eendebak, Daniel Egger, Mark Everitt, Paco Martín Fernández, Axel Hernández Ferrera, Romain Fouilland, Franck Chevallier, Albert Frisch, Andreas Fuhrer, MELVIN GEORGE, Julien Gacon, Borja Godoy Gago, Claudio Gambella, Jay M. Gambetta, Adhisha Gammanpila, Luis Garcia, Shelly Garion, Austin Gilliam, Aditya Giridharan, Juan Gomez-Mosquera, Salvador de la Puente González, Jesse Gorzinski, Ian Gould, Donny Greenberg, Dmitry Grinko, Wen Guan, John A. Gunnels, Mikael Haglund, Isabel Haide, Ikko Hamamura, Omar Costa Hamido, Vojtech Havlicek, Joe Hellmers, Lukasz Herok, Stefan Hillmich, Hiroshi Horii, Connor Howington, Shaohan Hu, Wei Hu, Rolf Huisman, Haruki Imai, Takashi Imamichi, Kazuaki Ishizaki, Raban Iten, Toshinari Itoko, James Seaward, Ali Javadi, Ali Javadi-Abhari, Jessica, Madhav Jivrajani, Kiran Johns, Jonathan-Shoemaker, Tal Kachmann, Naoki Kanazawa, Kang-Bae, Anton Karazeev, Paul Kassebaum, Spencer King, Knabberjoe, Yuri Kobayashi, Arseny Kovyrshin, Rajiv Krishnakumar, Vivek Krishnan, Kevin Kruslich, Gawel Kus, Ryan LaRose, Enrique Lacal, Raphaël Lambert, John Lapeyre, Joe Latone, Scott Lawrence, Christina Lee, Gushu Li, Dennis Liu, Peng Liu, Yunho Maeng, Aleksei Malyshev, Joshua Manela, Jakub Marecek, Manoel Marques, Dmitri Maslov, Dolph Mathews, Atsushi Matsuo, Douglas T. McClure, Cameron McGarry, David McKay, Dan McPherson, Srujan Meesala, Thomas Metcalfe, Martin Mevissen, Antonio Mezzacapo, Rohit Midha, Zlatko Mineev, Abby Mitchell, Nikolaj Moll, Michael Duane Mooring, Renier Morales, Niall Moran, MrF, Prakash Murali, Jan Muggenburg, David Nadlinger, Ken Nakanishi, Giacomo Nannicini, Paul Nation, Edwin Navarro, Yehuda Naveh, Scott Wyman Neagle, Patrick Neumeier, Pradeep Niroula, Hassi Norlen, Lee James O'Riordan, Oluwatobi Ogunbayo, Pauline Ollitrault, Steven Oud, Dan Padilha, Hanhee Paik, Yuchen Pang, Simone Perriello, Anna Phan, Francesco Piro, Marco Pistoia, Christophe Piveteau, Alejandro Pozas-iKerstjens, Viktor Prutyaynov, Daniel Puzzuoli, Jesús Pérez, Quintii, Rafey Iqbal Rahman, Arun Raja, Nipun Ramagiri, Anirudh Rao, Rudy Raymond, Rafael Martín-Cuevas Redondo, Max Reuter, Julia Rice, Diego M. Rodríguez, Rohith Karur, Max Rossmannek, Mingi Ryu, Tharmashastha SAPV, SamFerracin, Martin Sandberg, Ritvik Sapra, Hayk Sargsyan, Aniruddha Sarkar, Ninad Sathaye, Bruno Schmitt, Chris Schnabel, Zachary Schoenfeld, Travis L. Scholten, Eddie Schoute, Joachim Schwarm, Ismael Faro Sertage, Kanav Setia, Nathan Shammah, Yunong Shi, Adenilton Silva, Andrea Simonetto, Nick Singstock, Yukio Siraichi, Iskandar Sitdikov, Seyon Sivarajah, Magnus Berg Sletfjerding, John A. Smolin, Mathias Soeken, Igor Olegovich Sokolov, SooluThomas, Starfish, Dominik Steenken, Matt Stypulkoski, Shaojun Sun, Kevin J. Sung, Hitomi Takahashi, Ivano Tavernelli, Charles Taylor, Pete Taylour, Soolu Thomas, Mathieu Tillet, Maddy Tod, Miroslav Tomasik, Enrique de la Torre, Kenso Trabing, Matthew Treinish, TrishaPe, Wes Turner, Yotam Vaknin, Carmen Recio Valcarce, Francois Varchon, Almudena Carrera Vazquez, Victor Villar, Desiree Vogt-Lee, Christophe Vuillot, James Weaver, Rafal Wiecezorek, Jonathan A. Wildstrom, Erick Winston, Jack J. Woehr, Stefan Woerner, Ryan Woo, Christopher J. Wood, Ryan Wood, Stephen Wood, Steve Wood, James Wootton, Daniyar Yeralin, David Yonge-Mallo, Richard Young, Jessie Yu, Christopher Zachow, Laura Zdzanski, Helena Zhang, Christa Zoufal, and ZoufalC. Qiskit: An open-source framework for quantum computing, 2019.
- [32] Pierre-Luc Dallaire-Demers and Frank K. Wilhelm. Quantum gates and architecture for the quantum simulation of the Fermi-Hubbard model. *Phys. Rev. A*, 94:062304, Dec 2016.
- [33] Davide Venturelli, Minh Do, Eleanor Rieffel, and Jeremy Frank. Compiling quantum circuits to realistic hardware architectures using temporal planners. *Quantum Science and Technology*, 3(2):025004, 2018.

- [34] Yunong Shi, Nelson Leung, Pranav Gokhale, Zane Rossi, David I Schuster, Henry Hoffmann, and Frederic T Chong. Optimized compilation of aggregated instructions for realistic quantum computers. In *Proceedings of the Twenty-Fourth International Conference on Architectural Support for Programming Languages and Operating Systems*, pages 1031–1044, 2019.
- [35] Pranav Gokhale, Yongshan Ding, Thomas Propson, Christopher Winkler, Nelson Leung, Yunong Shi, David I Schuster, Henry Hoffmann, and Frederic T Chong. Partial compilation of variational algorithms for noisy intermediate-scale quantum machines. In *Proceedings of the 52nd Annual IEEE/ACM International Symposium on Microarchitecture*, pages 266–278, 2019.
- [36] Mahabubul Alam, Abdullah Ash-Saki, and Swaroop Ghosh. Circuit compilation methodologies for quantum approximate optimization algorithm. In *2020 53rd Annual IEEE/ACM International Symposium on Microarchitecture (MICRO)*, pages 215–228. IEEE, 2020.
- [37] Mahabubul Alam, Abdullah Ash-Saki, and Swaroop Ghosh. An efficient circuit compilation flow for quantum approximate optimization algorithm. In *2020 57th ACM/IEEE Design Automation Conference (DAC)*, pages 1–6. IEEE, 2020.
- [38] Mahabubul Alam, Abdullah Ash-Saki, Junde Li, Anupam Chattopadhyay, and Swaroop Ghosh. Noise resilient compilation policies for quantum approximate optimization algorithm. In *Proceedings of the 39th International Conference on Computer-Aided Design*, pages 1–7, 2020.
- [39] Gushu Li, Yunong Shi, and Ali Javadi-Abhari. Software-hardware co-optimization for computational chemistry on superconducting quantum processors. *arXiv preprint arXiv:2105.07127*, 2021.
- [40] Gushu Li, Anbang Wu, Yunong Shi, Ali Javadi-Abhari, Yufei Ding, and Yuan Xie. Paulihedral: A generalized block-wise compiler optimization framework for quantum simulation kernels. *arXiv preprint arXiv:2109.03371*, 2021.
- [41] Edward Farhi, Jeffrey Goldstone, and Sam Gutmann. A quantum approximate optimization algorithm. *arXiv:1411.4028*, 2014.
- [42] Andrew M Childs, Aaron Ostrander, and Yuan Su. Faster quantum simulation by randomization. *Quantum*, 3:182, 2019.
- [43] Earl Campbell. Random compiler for fast hamiltonian simulation. *Phys. Rev. Lett.*, 123:070503, Aug 2019.
- [44] Joonho Lee, William J Huggins, Martin Head-Gordon, and K Birgitta Whaley. Generalized unitary coupled cluster wave functions for quantum computation. *Journal of chemical theory and computation*, 15(1):311–324, 2018.
- [45] Abhinav Kandala, Antonio Mezzacapo, Kristan Temme, Maika Takita, Markus Brink, Jerry M Chow, and Jay M Gambetta. Hardware-efficient variational quantum eigensolver for small molecules and quantum magnets. *Nature*, 549(7671):242–246, 2017.
- [46] Werner Heisenberg. Zur theorie des ferromagnetismus. In *Original Scientific Papers Wissenschaftliche Originalarbeiten*, pages 580–597. Springer, 1985.
- [47] RKManojkumar Singh, Nishith Kumar Pal, Mandira Banerjee, Soma Sarkar, and Manideepa SenGupta. Surveillance on extended spectrum [beta]-lactamase and ampc [beta]-lactamase producing gram negative isolates from nosocomial infections. *Archives of clinical microbiology*, 3(3), 2012.
- [48] John J Hopfield. Neural networks and physical systems with emergent collective computational abilities. *Proceedings of the national academy of sciences*, 79(8):2554–2558, 1982.
- [49] J-S Wang, W Selke, VI S Dotsenko, and VB Andreichenko. The critical behaviour of the two-dimensional dilute ising magnet. *Physica A: Statistical Mechanics and its Applications*, 164(2):221–239, 1990.
- [50] Deanna M Abrams, Nicolas Didier, Blake R Johnson, Marcus P da Silva, and Colm A Ryan. Implementation of the XY interaction family with calibration of a single pulse. *arXiv preprint arXiv:1912.04424*, 2019.
- [51] B. Foxen, C. Neill, A. Dunsworth, P. Roushan, B. Chiaro, A. Megrant, J. Kelly, Zijun Chen, K. Satzinger, R. Barends, F. Arute, K. Arya, R. Babbush, D. Bacon, J. C. Bardin, S. Boixo, D. Buell, B. Burkett, Yu Chen, R. Collins, E. Farhi, A. Fowler, C. Gidney, M. Giustina, R. Graff, M. Harrigan, T. Huang, S. V. Isakov, E. Jeffrey, Z. Jiang, D. Kafri, K. Kechedzhi, P. Klimov, A. Korotkov, F. Kostritsa, D. Landhuis, E. Lucero, J. McClean, M. McEwen, X. Mi, M. Mohseni, J. Y. Mutus, O. Naaman, M. Neeley, M. Niu, A. Petukhov, C. Quintana, N. Rubin, D. Sank, V. Smelyanskiy, A. Vainsencher, T. C. White, Z. Yao, P. Yeh, A. Zalcman, H. Neven, and J. M. Martinis. Demonstrating a Continuous Set of Two-Qubit Gates for Near-Term Quantum Algorithms. *Phys. Rev. Lett.*, 125:120504, Sep 2020.
- [52] B. Kraus and J. I. Cirac. Optimal creation of entanglement using a two-qubit gate. *Phys. Rev. A*, 63:062309, May 2001.
- [53] Navin Khaneja, Roger Brockett, and Steffen J. Glaser. Time optimal control in spin systems. *Phys. Rev. A*, 63:032308, Feb 2001.
- [54] Marc Grau Davis, Ethan Smith, Ana Tudor, Koushik Sen, Irfan Siddiqi, and Costin Iancu. Heuristics for quantum compiling with a continuous gate set. *arXiv preprint arXiv:1912.02727*, 2019.
- [55] Lingling Lao, Prakash Murali, Margaret Martonosi, and Dan Browne. Designing calibration and expressivity-efficient instruction sets for quantum computing. In *ACM/IEEE 48th Annual International Symposium on Computer Architecture (ISCA)*, pages 846–859, 2021.
- [56] Mohammad Javad Dousti, Alireza Shafaei, and Massoud Pedram. Squash: a scalable quantum mapper considering ancilla sharing. In *Proceedings of the 24th edition of the great lakes symposium on VLSI*, pages 117–122, 2014.
- [57] Tayebah Bahreini and Naser Mohammadzadeh. A minlp model for scheduling and placement of quantum circuits with a heuristic solution approach. *ACM Journal on Emerging Technologies in Computing Systems (JETC)*, 12(3):1–20, 2015.
- [58] Lingling Lao, Bas van Wee, Imran Ashraf, J van Someren, Nader Khammassi, Koen Bertels, and Carmen G Almudefver. Mapping of lattice surgery-based quantum circuits on surface code architectures. *Quantum Science and Technology*, 4(1):015005, 2018.
- [59] Sartaj Sahni and Teofilo Gonzalez. P-complete approximation problems. *J. ACM*, 23(3):555–565, July 1976.
- [60] Fred Glover. Tabu search—part I. *ORSA Journal on computing*, 1(3):190–206, 1989.
- [61] Fred Glover. Tabu search—part II. *ORSA Journal on computing*, 2(1):4–32, 1990.
- [62] Rainer E Burkard and Franz Rendl. A thermodynamically motivated simulation procedure for combinatorial optimization problems. *European Journal of Operational Research*, 17(2):169–174, 1984.
- [63] Yong Li, Panos M Pardalos, and Mauricio GC Resende. A greedy randomized adaptive search procedure for the quadratic assignment problem. *Quadratic assignment and related problems*, 16:237–261, 1993.
- [64] Swami S Tannu and Moinuddin K Qureshi. Not All Qubits Are Created Equal: A Case for Variability-Aware Policies for NISQ-Era Quantum Computers. In *Proceedings of the Twenty-Fourth International Conference on Architectural Support for Programming Languages and Operating Systems*, pages 987–999. ACM, 2019.
- [65] Yongshan Ding, Xin-Chuan Wu, Adam Holmes, Ash Wiseth, Diana Franklin, Margaret Martonosi, and Frederic T Chong. SQUARE: strategic quantum ancilla reuse for modular quantum programs via cost-effective uncomputation. In *2020 ACM/IEEE 47th Annual International Symposium on Computer Architecture (ISCA)*, pages 570–583. IEEE, 2020.
- [66] Farrokh Vatan and Colin Williams. Optimal quantum circuits for general two-qubit gates. *Phys. Rev. A*, 69:032315, Mar 2004.
- [67] G. Vidal and C. M. Dawson. Universal quantum circuit for two-qubit transformations with three controlled-NOT gates. *Phys. Rev. A*, 69:010301, Jan 2004.
- [68] Tommy R Jensen and Bjarne Toft. *Graph coloring problems*, volume 39. John Wiley & Sons, 2011.
- [69] Nathan Lacroix, Christoph Hellings, Christian Kraglund Andersen, Agustin Di Paolo, Ants Remm, Stefania Lazar, Sebastian Krinner, Graham J. Norris, Mihai Gabureac, Johannes Heinsoo, Alexandre Blais, Christopher Eichler, and Andreas Wallraff. Improving the performance of deep quantum optimization algorithms with continuous gate sets. *PRX Quantum*, 1(2):110304, 2020.
- [70] Matthew P Harrigan, Kevin J Sung, Matthew Neeley, Kevin J Satzinger, Frank Arute, Kunal Arya, Juan Atalaya, Joseph C Bardin, Rami Barends, Sergio Boixo, Michael Broughton, Bob B Buckley, David A Buell, Brian Burkett, Nicholas Bushnell, Yu Chen, Zijun Chen, Ben Chiaro, Roberto Collins, William Courtney, Sean Demura, Andrew Dunsworth, Daniel Eppens, Austin Fowler, Brooks Foxen, Craig Gidney, Marissa Giustina, Rob Graff, Steve Habegger, Alan Ho, Sabrina Hong, Trent Huang, L B Ioffe, Sergei V Isakov, Evan Jeffrey, Zhang Jiang, Cody Jones, Dvir Kafri, Kostyantyn Kechedzhi, Julian Kelly, Seon Kim, Paul V Klimov, Alexander N Korotkov, Fedor Kostritsa, David Landhuis, Pavel Laptev, Mike Lindmark, Martin Leib, Orion Martin, John M Martinis, Jarrod R McClean, Matt McEwen, Anthony Megrant, Xiao Mi, Masoud Mohseni, Wojciech Mroczkiewicz, Josh Mutus, Ofer Naaman, Charles Neill, Florian Neukart, Murphy Yuezhen Niu, Thomas E O'Brien, Bryan O'Gorman, Eric Ostby, Andre Petukhov, Harald Putterman, Chris Quintana, Pedram Roushan, Nicholas C Rubin, Daniel Sank, Andrea Skolik, Vadim Smelyanskiy, Doug Strain, Michael Streif, Marco Szalay, Amit Vainsencher, Theodore White, Z Jamie Yao, Ping Yeh, Adam Zalcman, Leo Zhou, Hartmut Neven, Dave Bacon, Erik Lucero, Edward Farhi, and Ryan Babbush. Quantum approximate optimization of non-planar graph problems on a planar superconducting processor. *Nature physics*, 17(3):332–336, February 2021.
- [71] Quantum AI team and collaborators. ReCirq, October 2020.
- [72] Cirq Developers. Cirq, May 2021. See full list of authors on Github: <https://github.com/quantumlib/Cirq/graphs/contributors>.
- [73] Rainer E Burkard, Eranda Cela, Panos M Pardalos, and Leonidas S Pitsoulis. The quadratic assignment problem. In *Handbook of combinatorial optimization*, pages 1713–1809. Springer, 1998.
- [74] Chi-Fang Chen, Hsin-Yuan Huang, Richard Kueng, and Joel A Tropp. Quantum simulation via randomized product formulas: Low gate complexity with accuracy guarantees. *arXiv preprint arXiv:2008.11751*, 2020.
- [75] Yingkai Ouyang, David R White, and Earl T Campbell. Compilation by stochastic Hamiltonian sparsification. *Quantum*, 4:235, 2020.
- [76] Paul K Faehrmann, Mark Steudtner, Richard Kueng, Maria Kieferova, and Jens Eisert. Randomizing multi-product formulas for improved Hamiltonian simulation. *arXiv preprint arXiv:2101.07808*, 2021.
- [77] Ewout van den Berg and Kristan Temme. Circuit optimization of Hamiltonian simulation by simultaneous diagonalization of Pauli clusters. *Quantum*, 4:322, 2020.
- [78] Alexander Cowtan, Will Simmons, and Ross Duncan. A generic compilation strategy for the unitary coupled cluster ansatz. *arXiv preprint arXiv:2007.10515*, 2020.

- [79] Matthew B Hastings, Dave Wecker, Bela Bauer, and Matthias Troyer. Improving quantum algorithms for quantum chemistry. *arXiv preprint arXiv:1403.1539*, 2014.
- [80] Kaiwen Gui, Teague Tomesh, Pranav Gokhale, Yunong Shi, Frederic T Chong, Margaret Martonosi, and Martin Suchara. Term grouping and travelling salesperson for digital quantum simulation. *arXiv preprint arXiv:2001.05983*, 2020.
- [81] Alexander Cowtan, Silas Dilkes, Ross Duncan, Will Simmons, and Seyon Sivaram. Phase gadget synthesis for shallow circuits. *arXiv preprint arXiv:1906.01734*, 2019.
- [82] Arianne Meijer-van de Griend and Ross Duncan. Architecture-aware synthesis of phase polynomials for NISQ devices. *arXiv preprint arXiv:2004.06052*, 2020.
- [83] Prakash Murali, David C McKay, Margaret Martonosi, and Ali Javadi-Abhari. Software Mitigation of Crosstalk on Noisy Intermediate-Scale Quantum Computers. In *Proceedings of the Twenty-Fifth International Conference on Architectural Support for Programming Languages and Operating Systems*, pages 1001–1016, 2020.
- [84] Ian D. Kivlichan, Jarrod McClean, Nathan Wiebe, Craig Gidney, Alán Aspuru-Guzik, Garnet Kin-Lic Chan, and Ryan Babbush. Quantum simulation of electronic structure with linear depth and connectivity. *Phys. Rev. Lett.*, 120:110501, Mar 2018.
- [85] Kristan Temme, Sergey Bravyi, and Jay M. Gambetta. Error mitigation for short-depth quantum circuits. *Phys. Rev. Lett.*, 119:180509, Nov 2017.
- [86] Ying Li and Simon C. Benjamin. Efficient variational quantum simulator incorporating active error minimization. *Phys. Rev. X*, 7:021050, Jun 2017.
- [87] Sergey Bravyi, Sarah Sheldon, Abhinav Kandala, David C. McKay, and Jay M. Gambetta. Mitigating measurement errors in multiqubit experiments. *Phys. Rev. A*, 103:042605, Apr 2021.
- [88] Swamit S Tannu and Moinuddin K Qureshi. Mitigating measurement errors in quantum computers by exploiting state-dependent bias. In *Proceedings of the 52nd Annual IEEE/ACM International Symposium on Microarchitecture*, pages 279–290, 2019.