

# **A Two-Stage Ceramic Tile Grout Sealing Process Using A High Power Diode Laser**

## **Part II: Mechanical, Chemical And Physical Properties**

J. Lawrence \*, L. Li \* and J.T. Spencer \*\*

\* Manufacturing Division, Department of Mechanical Engineering, University of Manchester  
Institute of Science and Technology (UMIST), Manchester, M60 1QD, UK.

\*\* Research & Technology, B709, BNFL, Springfields Works, Salwick, Preston,  
Lancashire, PR4 0XJ, UK.

### **Correspondence**

Mr. Jonathan Lawrence / Dr. Lin Li

Manufacturing Division,

Department of Mechanical Engineering,

University of Manchester Institute of Science and Technology (UMIST),

Manchester,

M60-1QD,

UK.

Tel : (44) 161 236 3311 ext. 2383 / (44) 161 236 3311 ext. 3816

Fax : (44) 161 200 3803

email : Jonathan.Lawrence@stud.umist.ac.uk / L.Li@umist.ac.uk

## ABSTRACT

Ceramic tiles sealed using a portable 60 W-cw high power diode laser (HPDL) and a specially developed grout material having an impermeable enamel surface glaze have been tested in order to determine the mechanical, chemical and physical characteristics of the seals. The work showed that the generation of the enamel surface glaze resulted in a seal with improved mechanical and chemical properties over conventional epoxy tile grouts. Both epoxy tile grout and laser generated enamel seals were tested for compressive strength, surface roughness, wear, water permeability and acid/alkali resistance. The enamel seal showed clear improvements in strength, roughness and wear, whilst being impermeable to water, and resistance (up to 80% concentration) to nitric acid, sodium hydroxide and detergent acids. The bond strength and the rupture strength of the enamel seal were also investigated, revealing that the enamel adhered to the new grout and the ceramic tiles with an average bond strength of 45-60 MPa, whilst the rupture strength was comparable to the ceramic tiles themselves. The average surface roughness of the seals and the tiles was 0.36 $\mu$ m and 0.06 $\mu$ m respectively, whilst for the conventional epoxy grout the average surface roughness when polished was 3.83 $\mu$ m, and in excess of 30 $\mu$ m without polishing. Life assessment testing revealed that enamel seals had an increase in actual wear life of 2.9 to 30.4 times over conventional epoxy tile grout, depending upon the corrosive environment.

**Keywords:** high power diode laser, ceramic tiles, grout, vitrify, enamel, glaze, wettability, adhesion, bond strength, wear, roughness, permeability, corrosion resistance

## **INTRODUCTION**

Ceramic tiles are applied to the walls and floors in a whole host of places; from hospital operating theatres to industrial clean-rooms. However, such tiled surfaces can allow contaminants to enter into, and exit a space via a tiled surface, through the porous tile grouts used to fill the void between adjoining tiles; resulting in water, germs and other harmful agents often permeating into cavities behind the tiles, corroding the bonding agent used to fix the tile to the substrate, the substrate itself or even the ceramic tile. Moreover, the predominant problem with commercially available tile grouts is that because they are very difficult to clean, over time they become contaminated, and have to be removed physically or mechanically; an arduous and costly undertaking.

As has been demonstrated in Part I of the paper, using a new form of tile grout, it is feasible to produce a laser induced impervious surface glaze on a vitreous enamel coating applied to the surface of an amalgamated compound oxide grout (AOCG) placed in the void between adjoining vitrified ceramic tiles, thus sealing and joining together the tiles permanently. The AOCG proved to be a most suitable base material, bonding well to the ceramic tiles even at elevated temperatures, and allowing the laser glazed enamel coating to wet, and therefore bond well, to the surface (see Part I of this paper).

In this paper we report on the mechanical and chemical testing of the laser generated seals in comparison with existing epoxy tile grouts, in order to determine the physical properties of both materials. Mechanical tests on the seals were conducted to determine such properties as smoothness, rupture and impact strength, bond strength and permeability to water. Also, chemical tests were carried out to examine the corrosion resistance of the bonds with regard to mineral acid (nitric and sodium hydroxide) and detergent. In order to analyse the laser treated specimens, they were sectioned with a Struers cutting machine using a diamond rimmed cutting blade, and then polished using cloths and diamond suspension pastes. The sectioned samples were then examined using optical microscopy, SEM, EDAX, and XRD techniques.

## **EXPERIMENTAL PROCEDURE AND RESULTS**

Current British and international standards, in relation to tile grout, are concerned only with water absorption and compressive strength, whilst for actual ceramic tiles, standard tests exist for the determination of water absorption and chemical resistance. Consequently, it was not possible to test

the laser generated seals according to, and strictly adhering to, established tests. As such, wherever possible tests based on current standards were developed to investigate specific aspects of particular relevance to the laser generated seals; namely the pull-off strength, the surface roughness, the rupture strength, the wear resistance, the permeability characteristics (water) and the corrosion resistance.

### **Pull-Off Testing**

In order to test the bond strength of the laser treated AOCG and the enamel seal to the laser treated AOCG and ceramic tile surface, as well as the strength of the enamel coated AOCG, pull-off tests were conducted. For the tests the AOCG, enamel/AOCG and the enamel/ceramic tile were prepared as large area samples (10mm x 10mm). For the tests on the complete seal the ceramic tiles were cut into smaller pieces (20 x 20mm) and applied in pairs using an Araldite epoxy to an ordinary Portland cement (OPC) substrate and allowed to cure for 24 hours. The spacing between the vitrified edges of each tile pair was the industry recommended 1.5mm. The samples were then laser sealed as described in Part I of this paper. High tensile aluminium test dollies were then attached onto the surfaces and to the axially opposite substrate surfaces using Araldite epoxy and left to cure for 24 hours. In order to ensure axial accuracy (essential for true results), the test dollies were set in position using identical V-blocks. As shown in Figure 1, the samples were placed into an Instron 4507 tensile/compressive test rig by mounting the test dollies into the jaws of the rig. A tensile force was then applied until failure, with the energy being recorded.

The results obtained for the AOCG varied markedly with changes in the laser operating parameters, as Figure 2 shows. A post-test analysis of the samples showed that the material failed approximately 150µm below the laser treated surface in the HAZ. An optical analysis of the detached surfaces showed that the enamel had detached cleanly and completely from both the AOCG and the ceramic tile at the interface.

For the enamel/AOCG and the enamel/ceramic tile the average bond strength was recorded as 60 MPa and 45 MPa respectively. The results obtained from the tests showed little variation within the optimum laser operating parameters (shown in Part I), indicating that neither the power density nor the traverse speed influenced the bond strength of the enamel.

### **Surface Roughness Testing**

An important feature of the enamel seal is its surface roughness; since it is this that determines the cleanability of the tile surface as a whole. Using the Taylor-Hobson Surtronic 3+ surface texture measuring instrument, a series of measurements were taken on the surface of a layer of an epoxy grout (polished to ensure a measurement could be taken), the vitrified surface of a ceramic tile and the surface of a laser generated enamel seal. On each sample four measurements were taken in different positions and in different directions on the surface, with an average being taken. Table 1 summarises the surface roughness (Ra) measurement results.

As Table 1 shows, the surface roughness of the enamel seal is many times less than that of a conventional epoxy grout, even when polished. In ordinary operating conditions where the surface roughness of the epoxy grout is not polished, but is determined by the means of application, the surface roughness was measured in excess of 30 $\mu$ m. Clearly, in this situation the surface roughness, and therefore the cleanability, of the enamel seal will be considerably better.

### **Rupture Strength Testing**

Tests were conducted to determine the rupture strength of the enamel glaze when comprising a complete seal and the vitreous glaze on the surface a ceramic tile. Test samples were prepared as described in Section 2.1. The samples were placed onto the sample stage of the Instron 4507 tensile/compressive test rig and then subjected to a compressive rupture force until the enamel seal failed (cracked), as shown in Figure 3, with the energy being recorded. The rupture force was applied by means of a high tensile steel indenter with a 1mm radius point.

The results of the test are summarised in Table 2. As one can see there was little variation between the average rupture strength of the enamel seal and the vitreous tile glaze, 2.6 J and 3.0 J; with the enamel seal ranging from 2.3-2.7 J, whilst the vitreous tile glaze ranged from only 2.9-3.0 J. However, because of the shape of the tile edges, the enamel seal, when laser fired, naturally assumes a concave surface geometry. Thus, the strains within the enamel layer are higher, therefore reducing the strength (if the enamel was of a flat surface profile) by some 40-50% [1].

It is well established that substrate thickness has a significant effect upon the rupture strength of an enamel coating [1]. Therefore, because the thickness of the AOCG was not controlled as accurately as the thickness of the bulk ceramic tile material, slight variations in the recorded rupture strength are perhaps to be expected.

## **Wear Testing**

The wear resistance of a material in general is determined primarily by the hardness of the material in comparison with the hardness of other materials with which it comes into contact [2]. As such, the greater hardness of the compositional components of the enamels used on ceramic tiles and for the sealing of ceramic tiles (principally  $\text{SiO}_2$ ,  $\text{B}_2\text{O}_3$ ,  $\text{Na}_2\text{O}$  and Mn) in comparison with epoxy tile grouts (principally  $\text{CaCO}_3$  and dolomite) probably results in improved wear resistance. However, wear resistance does not always increase with hardness [3]. Tests were therefore conducted in accordance with Figure 4 to determine the exact difference in wear resistance between the conventional epoxy tile grout, the vitreous glaze on the ceramic tile surface and the enamel seal itself. In the case of the epoxy tile grout and the enamel seal the test samples were prepared as described in Section 2.1, whilst for the ceramic tile the test piece was simply a 25 x 25mm section. The test samples, in all cases, were then adhered using a Loctite adhesive to an OPC substrate. The samples were then weighed and subjected to a friction force for 8 hours, being removed from the machine and weighed at two hourly intervals.

Figure 5 shows the relationship between weight loss and the friction time for all three tests pieces. As one can see, the wear resistance of the enamel seal is fractionally greater than that of the vitreous glaze on the ceramic tile surface. However, the enamel seal shows a considerable increase in wear resistance over the epoxy tile grout, with the weight loss being 4 times lower than for the epoxy tile grout after 4 hours, and 8 times lower after 8 hours.

## **Permeability Testing**

Perhaps the most important function of the enamel seal is its capability of preventing harmful agents from permeating through it. In order to test the permeability of the enamel, comparison experiments with conventional epoxy tile grout were conducted in terms of water permeability. The tests were based on BS 6906 [4]. For the experiment, the ceramic tiles were cut into smaller pieces (20 x 20mm) and applied in pairs using a commercial tile grout to a ceramic tile substrate and allowed to cure for 24 hours. The spacing between the vitrified edges of each tile pair was the industry recommended 1.5mm. The samples were then filled in the conventional way with tile grout or laser sealed as described in Experimental Procedure. A scaled glass tube 1.2m long with an outside diameter of 12mm and an inside diameter of 10mm was luted and sealed completely onto the samples using a silicone sealer and a Loctite adhesive. The tubes were then filled with water to a height of 1m so as to

give a reasonable pressure head, and bunged to prevent any evaporation. Figure 6 details the experimental set-up. The whole set-up was then weighed. The experiments were carried out in a temperature controlled room held at  $15^{\circ}\text{C} \pm 3^{\circ}\text{C}$  for 72 hours.

On completion of the experiments, measuring and weighing of the test equipment revealed that the conventional epoxy tile grout had an average water permeability of approximately  $4.18 \times 10^{-3} \text{ mg/h.cm}^2$ , whilst the enamel seal displayed no measurable permeability. Such a result confirms that, not only is the enamel seal fully amorphous, but that since there are no cracks or porosities in the enamel glaze or the interface between the enamel glaze and the borosilicate glass tile surface, it is reasonable to assume that a continuous impervious surface has therefore been created across the surface of the tiles and the seal.

### **Corrosion Resistance Testing**

Tiled surfaces are often subjected to corrosive substances; as part of the normal service environment and/or as a result of routine cleaning. Therefore corrosion resistance tests based upon BS 6431 [5] were conducted using nitric acid, sodium hydroxide and Premier Products MP9 detergent cleaner. The experiments were carried out by dropping small amounts of the corrosive agents in the concentration ratios of 80%, 60%, 40%, 20% and 10% on to the surface of the epoxy tile grout, the AOCG and the enamel seal at hourly intervals for four hours. The samples were then examined optically and mechanically tested in terms of compressive strength and wear. High concentrations of the various corrosive agents were used principally to accelerate the tests. However, in practice 60% nitric acid is used within the nuclear processing industry as a solvent for nuclear fuels, whilst within the food processing and brewing industries, tiled surfaces are washed repeatedly many times a day with detergent cleaners [6].

All three substances in the concentrations 80%, 60% and 40% were seen to immediately attack the epoxy tile grout surface, with the nitric acid and sodium hydroxide attacking with greater severity than the detergent, whilst the enamel seal displayed no discernible microstructural changes or signs of divitrification due to corrosion. Also, it was seen that the AOCG displayed a similar resistance to reagent exposure as the enamel seal. This similar acid resistance of the AOCG with the enamel seal indicates that a seal comprising of the AOCG with a laser gazed enamel coating could function correctly in situ, even if the enamel coating became damaged. Figure 7 (a, b and c) shows the surface condition of the epoxy tile grout before and after exposure to all three reagents at 80% concentration.

Tests conducted according to ASTM C579-91 [7] revealed that exposure of the epoxy tile grout to the reagents had a significant effect upon the compressive strength and the wear resistance of the epoxy grout. As Figure 8 shows, exposure of the epoxy grout to nitric acid and sodium hydroxide in the concentrations 40-80% resulted in an average loss of compressive strength of approximately 35-71%. In the case of the detergent a significant loss in compressive strength only occurred with concentrations above 40%. Here the average loss in compressive strength for concentrations in the range 60-80% was approximately 15-30%. This compares with no discernible difference in either the wear resistance or the compressive strength of the AOCG, and for the enamel seal, neither the wear resistance nor the rupture strength.

Figure 9 shows the variation in wear resistance of the epoxy tile grout when exposed to the reagents with an 80% concentration. As one can see, the wear resistance is significantly affected, particularly through interaction with the nitric acid and the sodium hydroxide. Here the weight loss was approximately 5 times higher than for the unexposed epoxy tile grout after 4 hours, and approximately 10 times higher after 8 hours for both acids. In the case of the detergent the weight loss was twice as high as that recorded for the unexposed epoxy tile grout after 4 hours, and 5 times higher after 8 hours.

## **DISCUSSION**

As the results of the mechanical and chemical tests show, the enamel seal significantly out performed the conventional epoxy tile grout in all the test areas. Indeed, in many instances the performance of the enamel seal approached, and occasionally surpassed, that of the ceramic tiles themselves. Moreover, the superior mechanical and chemical performance of the enamel seal over conventional epoxy grout suggests that the life characteristics of the enamel seal are also superior to those of conventional epoxy grout. This was especially true in the case of chemical resistance and water permeability, where the enamel seal proved to be resistant to both. This marked variation in corrosion resistance is due to the difference in composition of the epoxy tile grout and the AOCG and enamel. The epoxy tile grout consists largely of limestone and dolomite which are readily attacked by acids. In contrast, the inherently relatively high contents of  $\text{SiO}_2$  and  $\text{B}_2\text{O}_3$  in the AOCG and enamel composition ensure an increase in acid resistance [1]. The difference in permeability performance is due to the contrasts in structure of the epoxy tile grout and the enamel seal; with the epoxy tile grout



being comprised of a porous polycrystalline structure, whilst the structure of the enamel seal is of an amorphous nature.

However, the in-situ relative thickness of the epoxy tile grout and the enamel coating must be considered in order to give a true interpretation of the actual life characteristics, particularly when considering the wear resistance (with and without exposure to corrosive chemical agents). Table 3 summarises the wear rate details and the nominal life increase of the enamel seal over the conventional epoxy tile grout.

As Table 3 shows, the enamel seal gives an increase in actual life over the epoxy tile grout regardless of the environment. However, as one can see, the increase in actual life of the enamel seal over the epoxy tile grout varies markedly depending upon the working environment. But, notwithstanding this, the most common working environment for the enamel seal would involve contact with detergent acids, therefore yielding significant economic savings since such a tiled surface lasts around ten-times longer than one sealed with conventional epoxy tile grout.

## **CONCLUSION**

The use of a HPDL beam to produce a tough, inexpensive seal in the void between adjoining vitrified ceramic tiles using the newly developed AOCC sealed with an amorphous, impermeable, crack-free enamel coating has been demonstrated successfully. Life assessment testing revealed that enamel seals had an increase in wear life of 2.9 to 30.4 times over conventional epoxy tile grout, depending upon the corrosive environment. Whilst the rupture tests revealed that the rupture strength of the enamel seal was comparable to that of the ceramic tiles themselves. Clearly, the economic and material benefits to be gained from the deployment of such a more effective and efficient method of tile sealing could be significant.

Optical inspection and water permeability tests revealed that a complete bond between the amorphous enamel crack and porosity free glaze and the tiles, as well as the laser treated AOCC substrate, was achieved. Mechanical testing of the seals revealed that there was little variation between the average rupture strength of the enamel glaze and the vitreous ceramic tile surface, 2.6 J and 3.0 J respectively. For the enamel/AOCC and the enamel/ceramic tile the average bond strength was recorded as 60 Mpa and 45 Mpa respectively. The average surface roughness of the seals and the tiles was 0.36 $\mu$ m

and 0.06 $\mu\text{m}$  respectively, whilst for the conventional epoxy grout (polished) the average surface roughness was 3.83 $\mu\text{m}$ .

## ACKNOWLEDGEMENTS

The authors would like to express their gratitude to the EPSRC: Process Engineering Group (Grant No. GR/K99770), the EPSRC: CDP Group (CASE Award No. 95562556) and BNFL for their financial support. Many thanks also to Arthur Sumner of UMIST, for his invaluable help in running the tests, and Edward Simpkins of Ferro for sharing his time and expertise.

## REFERENCES

1. **Vargin, V.V.** *Technology of Enamels*, London: MacLaren & Sons (1965)
2. **Dickson, J.H.** *Glass: A Handbook for Students and Technicians*, London: Hutchinsons Scientific and Technical Publications (1951)
3. **Petitbon, A., Boquet, L., Delsart, D.** Laser Surface Sealing and Strengthening of Zirconia Coatings, *Surf. & Coat. Tech.*, **49** (1991), 57-61
4. BS 6906: Part 3: 1989, Determination of Water Flow Normal to the Plane of a Geotextile Under a Constant Head
5. BS 6431: Part 19: 1984, Ceramic Wall and Floor Tiles: Method for Determination of Chemical Resistance. Glazed Tiles
6. **Verran, J.** Letter to Author, October 1997
7. ASTM C597-91, Standards Test Method for Compressive Strength of Chemical-Resistant Mortars, Grouts, Monolithic Surfacing and Polymer Concretes

## LIST OF FIGURES

Figure 1 : Schematic of the experimental set-up for the pull-off tests.

Figure 2 : Relationship between strength of laser treated AOCG layer with laser operating parameters.

Figure 3 : Schematic of the experimental set-up for the rupture tests.

Figure 4 : Schematic of the experimental set-up for the wear tests.

Figure 5 : Relationship between weight loss and friction time for the conventional epoxy tile grout, the vitreous glaze on a ceramic tile surface and an enamel seal.

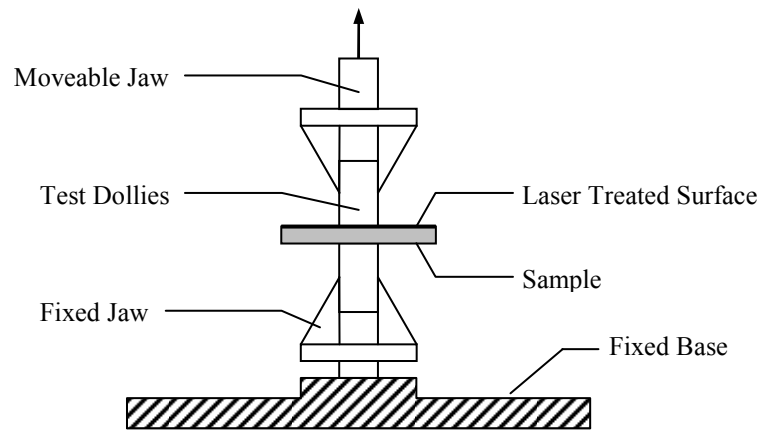
Figure 6 : Schematic of the experimental set-up for the water permeability tests.

Figure 7 : Surface condition of the epoxy tile grout (a) untreated and after exposure to (b) 80% concentration nitric acid, (c) 80% concentration sodium hydroxide acid and (d) 80% concentration detergent acid.

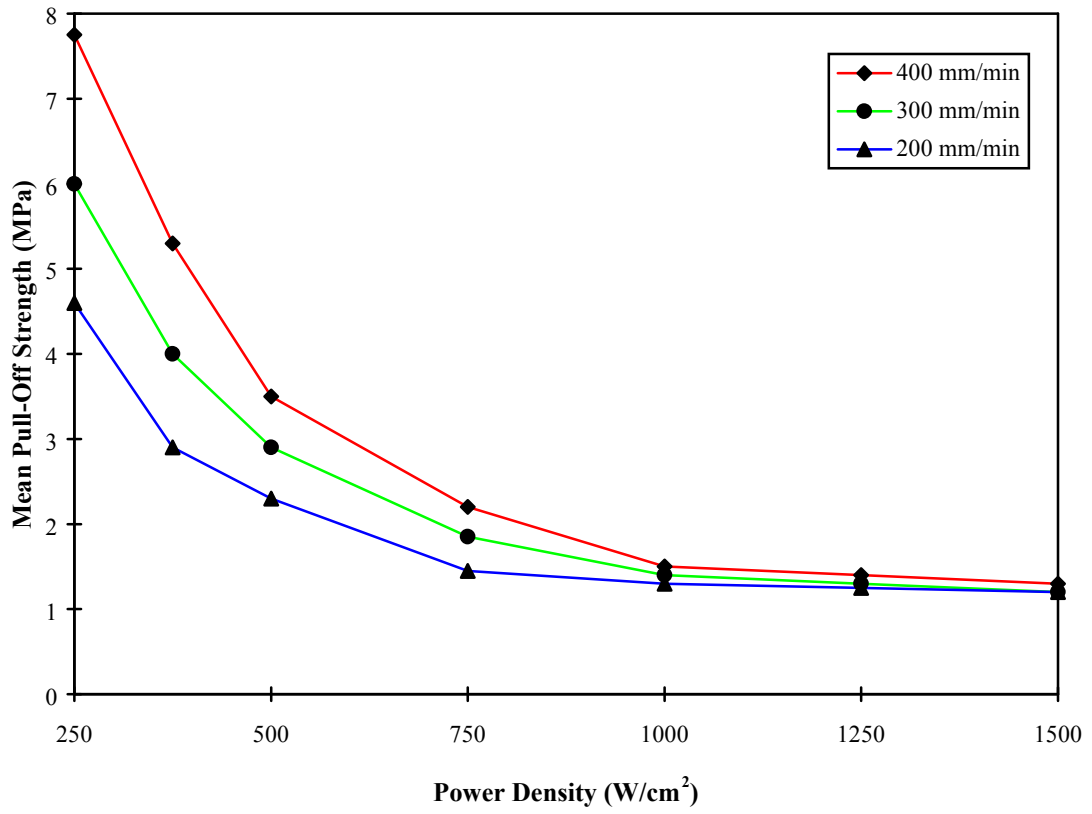
Figure 8 : Variation in compressive strength of epoxy tile grout with reagent type and reagent concentration.

Figure 9 : Relationship between weight loss and friction time for the epoxy tile grout with different reagent types at the maximum concentration (80%).

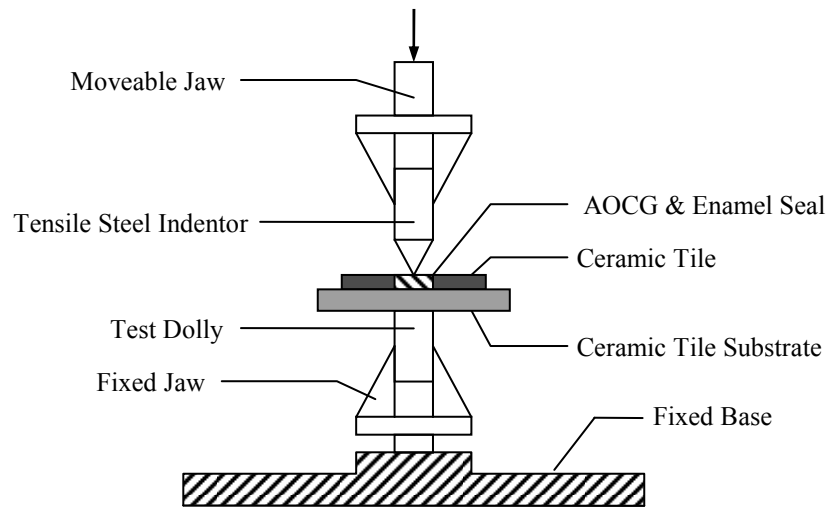
## **FIGURE 1**



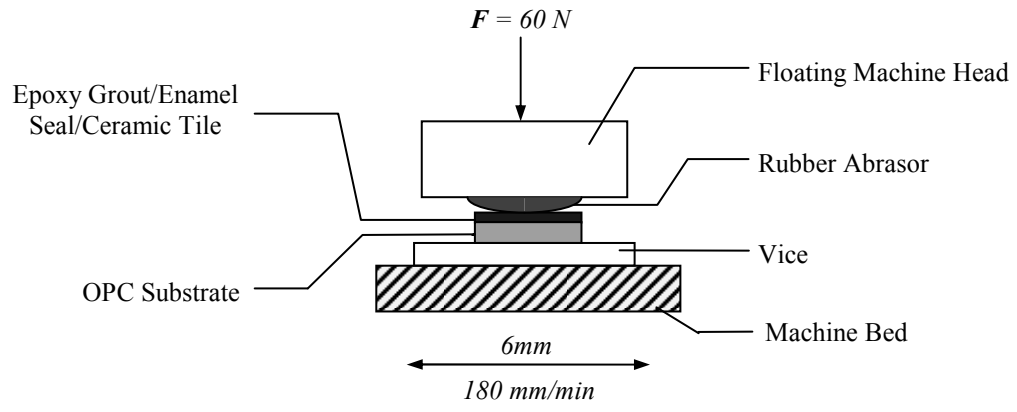
**FIGURE 2**



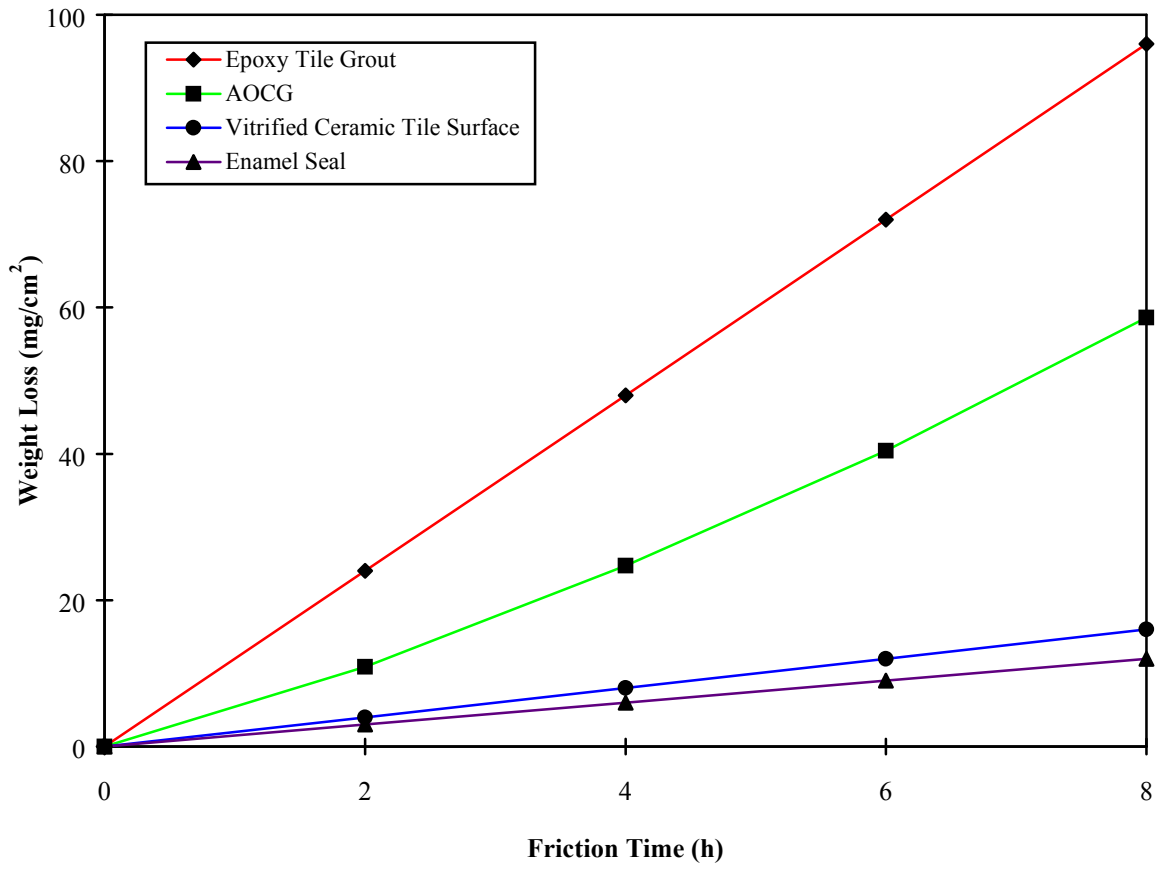
**FIGURE 3**



**FIGURE 4**

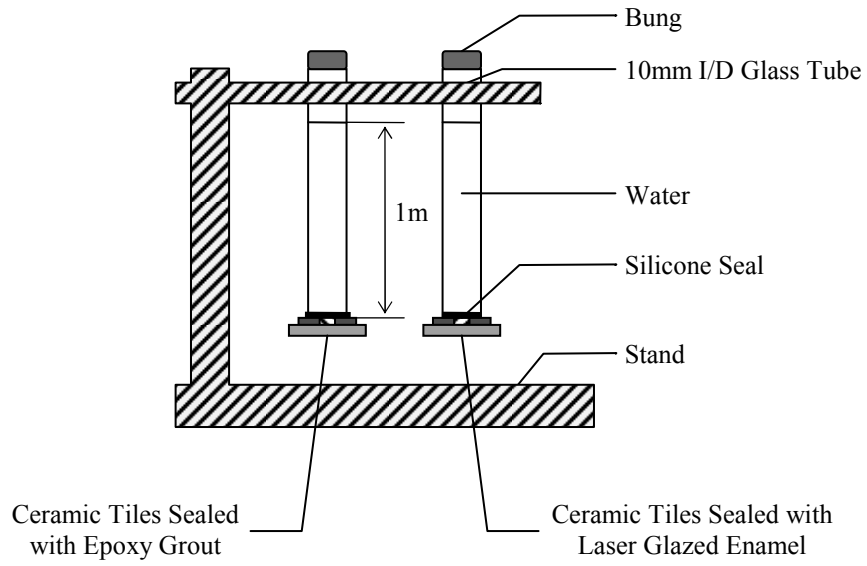


**FIGURE 5**





**FIGURE 6**



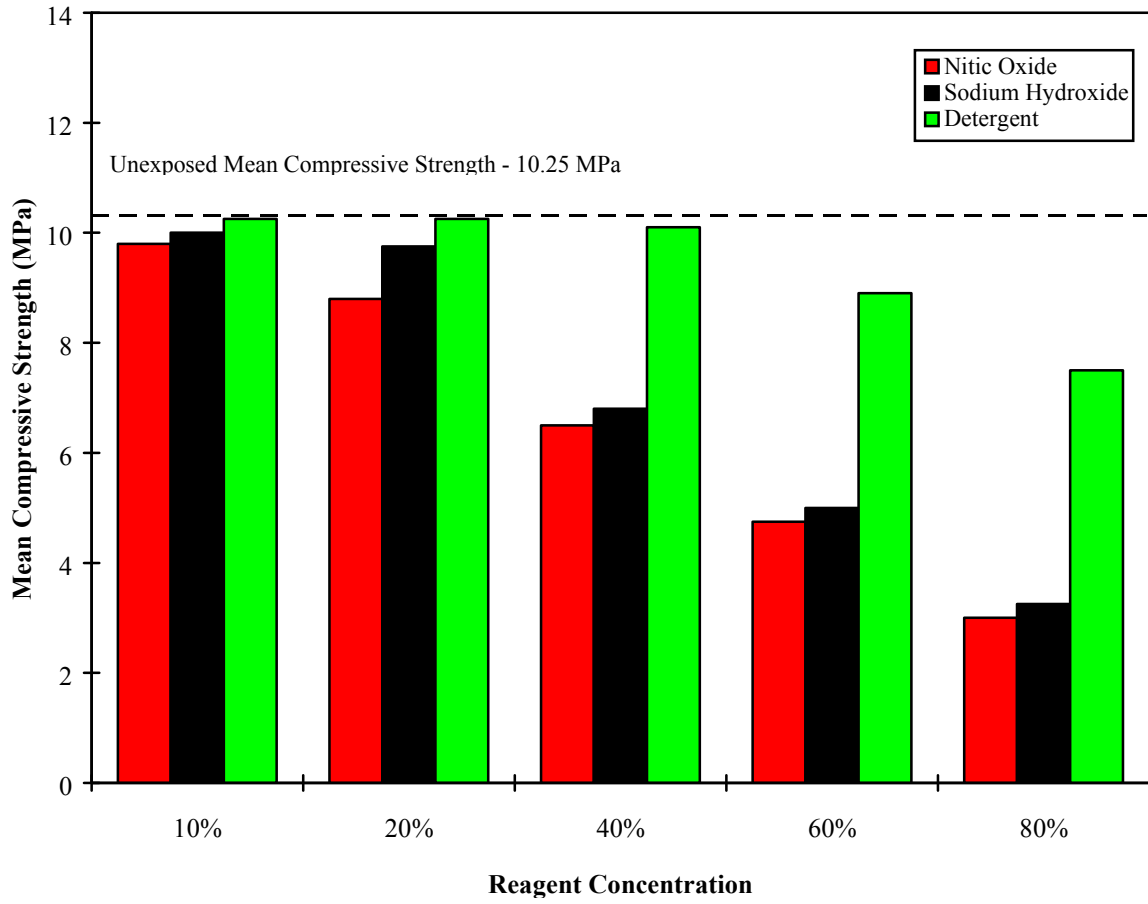
**FIGURE 7**

(a)

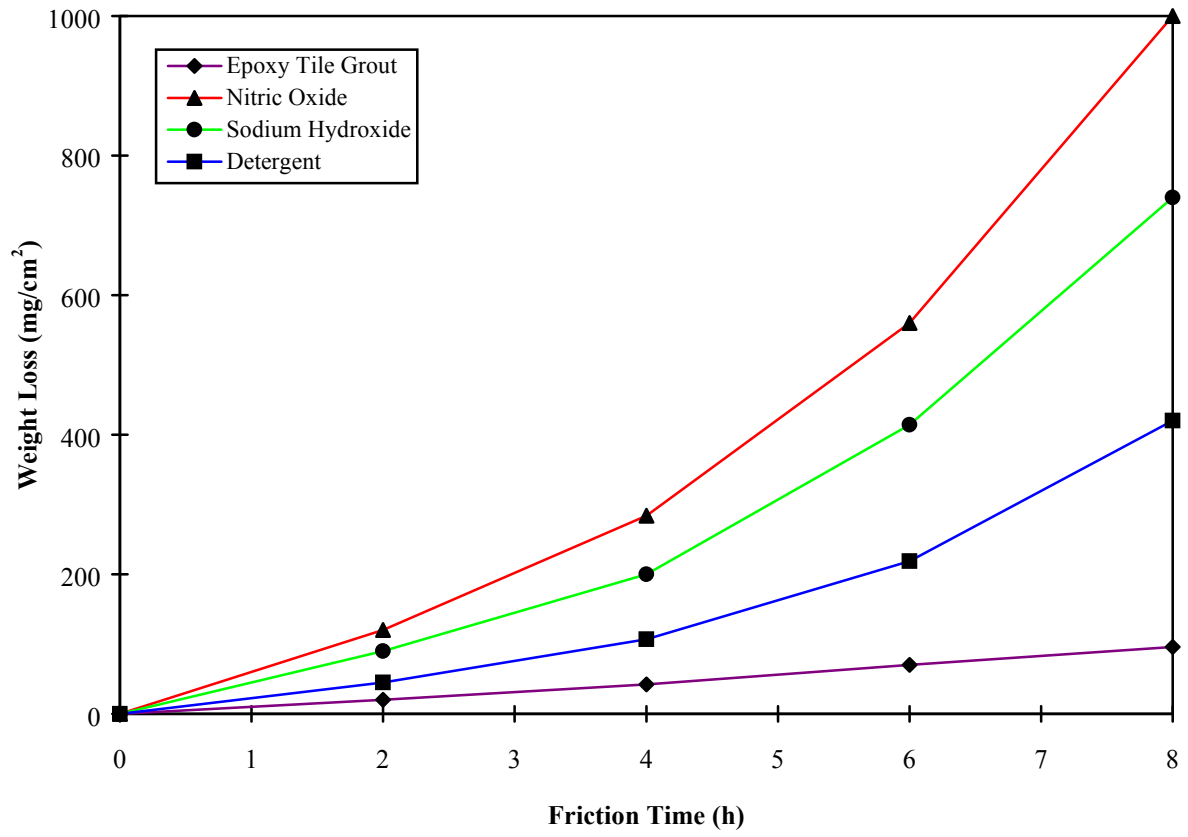
(b)

(c)

**FIGURE 8**



**FIGURE 9**



## LIST OF TABLES

Table 1 : Surface roughness (Ra) measurements for epoxy tile grout, ceramic tile and laser generated enamel seal.

Table 2 : Rupture strength measurements for ceramic tile and laser generated enamel seal.

Table 3 : Wear rate details and the nominal life increase of the enamel seal over conventional epoxy tile grout in various corrosive environments.

**Table 1**

Surface	Surface Roughness (Ra)	
	Range	Ave. Roughness
Epoxy Tile Grout	2.36-5.72 $\mu$ m	3.83 $\mu$ m
Ceramic Tile	0.06 $\mu$ m	0.06 $\mu$ m
Enamel Seal	0.20-0.64 $\mu$ m	0.36 $\mu$ m

**Table 2**

Material	Rupture Strength	
	Range	Average Strength
Ceramic Tile	2.9-3.0 J	3.0 J
Enamel Seal	2.3-2.7 J	2.6 J

**Table 3**

	Density	Thickness	Unexposed	Wear Rate (mg.cm <sup>-2</sup> .h <sup>-1</sup> )		
				Detergent	NaOH	HNO <sub>3</sub>
Epoxy Tile Grout	2180 kg/m <sup>3</sup>	2000µm	12.25	53.75	96.25	125
Enamel Seal	2650 kg/m <sup>3</sup>	500µm	1.25	1.25	1.25	1.25
<b>Increase in Wear Life *</b>	~	~	<b>2.9</b>	<b>13.1</b>	<b>23.4</b>	<b>30.4</b>

$$* \text{ Increase in Wear Life} = \frac{\text{Enamel Wear Life}}{\text{Epoxy Tile Grout Wear Life}}$$

$$\text{where, Wear Life} = \frac{\text{Density} \cdot \text{Thickness (mg.cm}^{-3} \cdot \text{cm)}}{\text{Wear Rate (mg.cm}^{-2} \cdot \text{h}^{-1})}$$