

Gernego Yu. O.

*Ph. D. in Economics,
Associate Professor of Corporate Finance and Controlling Department,
National Economic University named after Vadym Hetman, Ukraine;
e-mail: IuliiaGern@ukr.net; ORCID ID: 0000-0002-4929-0411*

Dyba O. M.

*Doctor of Economics, Associate Professor,
Professor of Corporate Finance and Controlling Department,
Kyiv National Economic University named after Vadym Hetman, Ukraine;
e-mail: dyba_m@ukr.net; ORCID ID: 0000-0002-3615-1180*

Petrenko L. A.

*Ph. D. in Economics, Associate Professor,
Associate Professor of Business Economics Department,
National Economic University named after Vadym Hetman, Ukraine;
e-mail: petrenko-78@ukr.net; ORCID ID: 0000-0001-7851-9644*

DETERMINANTS OF INNOVATIVE ACTIVITIES CONSERNING SOCIO-ECONOMIC GROWTH

Abstract. The national economy transition to innovative activities, connected with social and economic growth requires considerable determinants, which represent a competitive area for further social and economic growth in the context of globalization. The impacts on innovative activities are considerable in the context of understanding the complexity of social and economic growth within both the national and global level. Despite numerous researches and available achievements in the field of the nature and essence of innovative activities in the context of social and economic growth, there are still a lot of different questions, concerning their determinants. The purpose of the current study is to determine a wide range of approaches to define both innovative activities and socio-economic growth, considering the nature of innovative activities and different determinants on theoretical as well as on the empirical levels. Results from earlier studies demonstrate a strong and consistent association between micro economic determinants and innovative activities. But above mentioned points of views are pretty limited and do not include some important determinants for innovative activities and further socio-economic growth. The current study is different from prior ones. Firstly, it looks at investigated determinants, which influence on the innovative activities and socio-economic growth, empirically. Secondly, it considers for a vast amount of practical approaches, which create the possibility to consider and combine the determinants of innovative activities. Thirdly, this paper investigates the issue associated with innovative activities, connected with social and economic growth nowadays. Thus, the authors provide empirical models, which are developed in accordance with appropriate tendencies in national economy.

Keywords: models of innovative activity, socio-economic growth, innovation, internal and external factors of socio-economic growth, resources.

JEL Classification O1, O3, O4

Formulas: 1; fig.: 3; tabl.: 0; bibl.: 29.

Гернего Ю. О.

*кандидат економічних наук,
доцент кафедри корпоративних фінансів і контролінгу,
ДВНЗ «Київський національний економічний університет
імені Вадима Гетьмана», Україна;
e-mail: IuliiaGern@ukr.net; ORCID ID: 0000-0002-4929-0411*

Дйба О. М.

*доктор економічних наук, доцент,
професор кафедри корпоративних фінансів і контролінгу,
ДВНЗ «Київський національний економічний університет
імені Вадима Гетьмана», Україна;
e-mail: dyba_m@ukr.net; ORCID ID: 0000-0002-3615-1180*

Петренко Л. А.

*кандидат економічних наук, доцент,
доцент кафедри економіки підприємств,
ДВНЗ «Київський національний економічний університет
імені Вадима Гетьмана», Україна;
e-mail: petrenko-78@ukr.net; ORCID ID: 0000-0001-7851-9644*

ДЕТЕРМІНАНТИ ІННОВАЦІЙНОЇ АКТИВНОСТІ В КОНТЕКСТІ СОЦІАЛЬНО-ЕКОНОМІЧНОГО ЗРОСТАННЯ

Анотація. Зміна вектора розвитку національної економіки на інноваційній зумовила трансформацію моделей соціального та економічного зростання. Це вимагає диференціації детермінант, які є конкурентоспроможною сферою для подальшого соціально-економічного зростання в умовах глобалізації. Стаття репрезентує емпіричні дослідження внутрішніх і зовнішніх детермінантів інноваційної діяльності та соціально-економічного зростання. Низка попередніх досліджень була зосереджена на характеристиках і сутності інноваційної діяльності та соціально-економічного зростання. Проте для наявних праць характерна низка досить вагомих обмежень, що пов'язано із недостатнім урахуванням деяких важливих детермінант для інноваційної діяльності та подальшого соціально-економічного зростання. Незважаючи на численні дослідження та наявні досягнення щодо сутності та сутності інноваційної діяльності в контексті соціально-економічного зростання, ще існує багато різних питань, що стосуються їхніх детермінант. Наведене дослідження покликане обґрунтувати детермінанти інноваційної активності в контексті соціально-економічного зростання та відрізняється за своїми концептуальними характеристиками від наявних теорій. У процесі аналізу визначено широкий спектр підходів до диференціації як інноваційної діяльності, так і соціально-економічного зростання. По-перше, здійснено емпіричні дослідження чинників, які впливають на інноваційну діяльність. По-друге, стаття презентує низку практичних підходів, які створюють можливість розгляду і поєднання ознак інноваційної діяльності та соціально-економічного зростання. По-третє, у дослідженні розвинуто емпіричні моделі, які враховують тенденції інноваційної діяльності та соціально-економічного зростання в Україні. Таким чином, наведено емпіричні моделі, які розробляються відповідно до відповідних тенденцій у національній економіці.

Ключові слова: моделі інноваційної діяльності, соціально-економічне зростання, інновації, внутрішні і зовнішні чинники соціально-економічного зростання, ресурси.

Формул: 1; рис.: 3; табл.: 0; бібл.: 29.

Гернего Ю. А.

*кандидат економічних наук,
доцент кафедри корпоративних фінансів і контролінга,
ГВУЗ «Київський національний економічний університет
імені Вадима Гетьмана», Україна;
e-mail: IuliiaGern@ukr.net; ORCID ID: 0000-0002-4929-0411*

Дйба А. М.

*доктор економічних наук, доцент,
професор кафедри корпоративних фінансів і контролінга,
ГВУЗ «Київський національний економічний університет
імені Вадима Гетьмана», Україна;
e-mail: dyba_m@ukr.net; ORCID ID: 0000-0002-3615-1180*

Петренко Л. А.
кандидат экономических наук, доцент,
доцент кафедры экономики предприятий,
ГВУЗ «Киевский национальный экономический университет
имени Вадима Гетьмана», Украина;
e-mail: petrenko-78@ukr.net; ORCID ID: 0000-0001-7851-9644

ДЕТЕРМИНАНТЫ ИННОВАЦИОННОЙ АКТИВНОСТИ В КОНТЕКСТЕ СОЦИАЛЬНО-ЭКОНОМИЧЕСКОГО РОСТА

Аннотация. Представлено эмпирические исследования внутренних и внешних детерминант инновационной деятельности и социально-экономического роста. Ряд предыдущих исследований было сосредоточено на характеристиках и сущности инновационной деятельности и социально-экономического роста. Приведенное исследование призвано обосновать детерминанты инновационной активности в контексте социально-экономического роста. Во-первых, осуществлено эмпирические исследования факторов, которые влияют на инновационную деятельность. Во-вторых, статья представляет ряд практических подходов, которые создают возможность рассмотрения и сочетание признаков инновационной деятельности и социально-экономического роста. В-третьих, в исследовании получили развитые эмпирические модели, которые учитывают тенденции инновационной деятельности и социально-экономического роста в Украине.

Ключевые слова: модели инновационной деятельности, социально-экономический рост, инновации, внутренние и внешние факторы социально-экономического роста, ресурсы.

Формул: 1; рис.: 3; табл.: 0; библи.: 29.

Urgency of the research. The national aspiration to develop an innovative economy has to be based on the appropriate theoretical background and developed countries trends of forming the innovative society, in which a different kinds of determinants influence their positions within the world market. However, the national economy transition to innovative activities and socio-economic growth requires considerable inputs and outputs, which represent a competitive area for highly technological and competitive goods and services production, ensure the country's technical and technological safety and the strategic innovative success of national socio-economic growth in general. One of the most significant discussions is that in the recent years the innovative activities have experienced a variety of negative trends in national economy. It is impossible to eliminate most of such negative trends without raising the level of theoretical and practical orientation of innovative theory investigations.

Target setting. The innovative activities are vitally considerable in the context of understanding the complexity and potential for further socio-economic growth. Thus, determining the impacts on innovative activities is important for the further socio-economic growth.

Actual scientific researches and issues analysis. Over the past century, there has been a dramatic increase in research of innovative trends of socio-economic development and its determinants that is mainly with their considerable impact on national competitiveness. Surveys such as that conducted by Schumpeter J. (1943) have shown that the entrepreneur have to provide innovation for further competitiveness. On the other hand, he formalized the concept of «creative destruction» as a process «that incessantly revolutionizes the economic structure from within, incessantly destroying the old one, incessantly creating a new one» [1]. In the new global economy, the rules of the game of private property rights and decentralized markets provide powerful incentives for economic actors to innovate. Whether innovative activity is for the sake of the fruits of success, or for success itself, in price-making markets rewards are based on the competitive sorting and matching of quality and price. It is thus the restoration of consumer and producer sovereignty in transition economies, which activates incentives to innovate (Nee V., Kang J., Oppr S., 2010) [2]. The Oslo Manual (OECD, 2010) defines innovation as «the implementation of a new or significantly improved product (good or service), or process, a new marketing method, or a new organisational method in business practices, workplace organisation or external relations» [3]. This shows that innovation involves not only the generation of

new knowledge — invention or discovery — but also applying that new knowledge to meet a market need. Moreover, the Oslo Manual definition emphasises that innovation also encompasses new methods of production (process innovation), new ways of organising or managing the firm (managerial innovation), and new ways of opening up new opportunities (market innovation). Such definition highlights the «active» nature of innovations.

Furthermore, according to the Kirshin I.A., Datsyk A.A. and Titov A.V. (2013), the life cycle of innovations starts with a cumulative storage of the innovative resource (welfare). The achievement of a certain critical level of this resource generates a qualitative switch to the exponential growth of the innovative process [4]. It indicates the connection between the current innovative activity and current growth trends, which shows the possibility for further socio-economic growth. The results of the analyses regarding growth potential of young (innovative) firms (Almus M.; Nerlinger E. A.; Steil F., 1999) show, that innovative firms achieve significantly higher growth rates compared to non-innovative firms [5]. Positive effects on the growth rate can be found if the firm has links to external firms that can act as potential capital and/or know-how providers. Previous research suggests that being innovative can be a step toward realizing socio-economic growth, but being successful on the global market and achieving national economy growth are contingent upon a significant meagre of determinants as well (Uddenberg A., 2015) [6].

Uninvestigated parts of general matters defining. However, despite numerous achievements in the field of innovative activities and socio-economic growth, there are various points of views at the peculiarities of innovative activities determinants. According to the above mentioned information, more research is needed to understand why some innovative entities and national economies grow while others do not. Innovation should most likely be viewed in consideration with several determinants, and should therefore be studied in the broader context of national socio-economic growth. Despite significant number of scientific investigations in the area of innovative activities and socio-economic growth, there are a lot of issues, which need further development. One of such issues is the study of main innovative activities determinants. On the other hand, innovative activities are not the single indicator of such determinants effectiveness. According to our point of view, innovative activities have primarily internal focus, but it requires further developing, which is manifested within socio-economic growth.

The research objective. The purpose of current article is to determine different approaches to define both innovative activities and socio-economic growth, considering the nature of innovative activities and different determinants on theoretical as well as on the empirical levels. The research includes some theoretical points of views, which makes it a useful mean for their further understanding and practical implementation.

Comprehensive approach considering determinants of innovative activity and socio-economic growth. Innovative activities are differentiated according to the types and nature of innovations, which are mostly used or produced in national economy. There are a lot of external and internal determinants affecting product innovations, business process innovations or their combination. In particular, Acs Z. and Audretsch D. (1989) consider business entities size and structure, technological advance, market concentration among the determinants of innovative activities [7]. These measures have involved either some measures of an input into innovative process, such as R&D or else a proxy measure of innovative output, such as patented invention (Fig. 1).

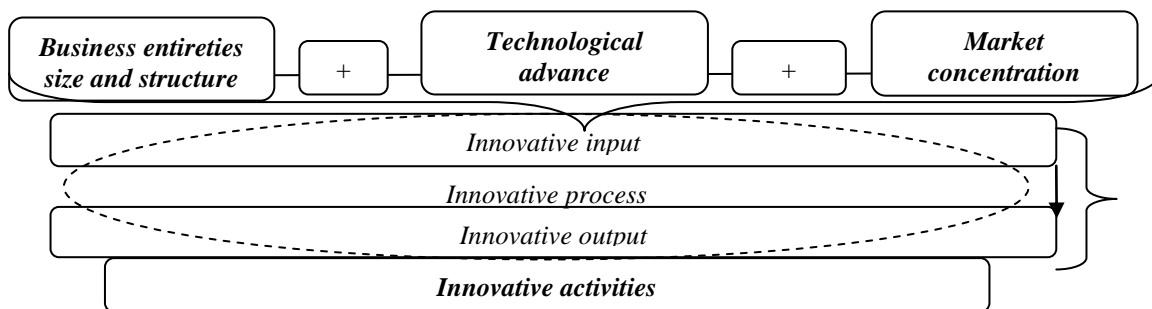

Fig. 1. Determinants of innovative activities (micro approach)

Source: considered by authors.

Hereby, results from earlier studies demonstrate a strong and consistent association between micro economic determinants and innovative activities. But above mentioned points of views are pretty limited and do not include some important determinants for innovative activities and further socio-economic growth. Despite of this, on the next step of our research we observe other approaches. For instance, the practical researches of PWC's experts pay attention mostly to the internal determinants, including: strong visionary business leadership (26 out of 103); having the right culture to foster and support innovation (26); the willingness to challenge managerial norms and take risks (9); collaborating with customers (9); having a capacity and capability for creativity (9); the ability to capture ideas throughout the organisation (9); being able to locate and train the right people (5); collaborating with suppliers (2); being able to secure the right levels of funding (1); use of new tech (such as social media) to support innovation (1); none/don't know (4) (first choice, PWC, 2016). Therefore, the first factor of innovative activity mostly has the internal origin. The same tendency we also observe by indication of Top — 3 innovative activities components, namely: having the culture to foster and support innovation (57 out of 291); strong visionary business leadership (44); the willingness to challenge managerial norms and take risks (37); the ability to capture ideas throughout the organisation (31); having a capability for creativity (31); collaborating with customers (30); being able to locate and train the right people (26); use of new technic (such as social media) to support innovation (11); collaborating with suppliers (11); being able to secure the right levels of funding (9); none/don't know (4) (Top-3 factors, PWC, 2016).

At the same time, among the determinants stopping innovative activities, most entities choose the internal and external ones, namely: financial resources (43 out of 176); existing managerial culture (41); lack of talent (30); political and regulatory factors (21); inadequate technology (18); nothing is stopping me from being innovative (14); weak governance/leadership (9) (PWC, 2016) [8]. The combination of internal and external determinants is mentioned in the context of socio-economic growth researches. However, the connection between innovative activities and socio-economic growth ambitions are represented in the works of Baum J., Locke E. (2004), Shane S., Locke E., Collins C. (2003), Delmar F., Wiklund G. (2013) [9 - 11]. Motivation is necessary but not a sufficient condition. Therefore, we agree with Uddenberg A. (2015), who suggests, that innovative activities and innovative products make the basis for socio-economic growth [6]. The generalizability of much published research on this issue is problematic. For instance, some authors focus their attention on the following factors, which influence the innovative activity: industry maturity, customer needs and expectations, technological opportunities, investment attractiveness, intensity of competition, business size, origin of ownership and export orientation [12—18].

The most of above mentioned determinants have only been carried out in the area of innovative activity. However, much of the research up to now has been descriptive in determinants both of innovative activities and socio-economic growth. For instance, those are in connection with the business size. However, the debate about the potential of innovative startups and other small firms for employment creation started long ago with the work of David Birch in the late 1970s (Birch D., 1979), and since then it has become one of the determinants of socio-economic growth [19]. Examples of researches of business size impact on socio-economic growth include Swedish experience Arvanitis S. (1997) [20]. The study has attempted to explain a model of innovation behaviour, concerning business size as an additional explanatory variable, an analysis of the relation between R&D expenditures and business size in total manufacturing and in several industries, as well as exploration of the size-dependence of model variables at the national level.

Central to the entire socio-economic growth research of Jaffe A. and Trajtenberg M. (2002) is the concept of «managerial skills and aspirations». The authors hypothesized and found that managers with higher aspirations for growth also achieved higher levels of growth, but both their aspirations and realized growth are enhanced by more human capital (such as education and experience), access to financial capital and dynamism in the environment [21].

Determinants of socio-economic growth have being studied by Oakey R. (1993, 1994), Storey D. and Tether B. (1996) and Nerlinger Ch. (1998) concerning new technologies as the primary source of new employment and the engine of technological change and socio-economic growth [22—25]. Thus,

technological changes play a vital role in the socio-economic growth. However, a wide range of investments is essential for a wide range of technologies development. In particular, Brissimis S. and Kosma T. (2005), Link R. and Bozeman P. (1991) assume that business finances investment in process innovation from its own resources, including using a proportion of its output, in order to abstract from the bureaucratic constraints influence [26—30].

Empirical model. Due to practical constraints, this paper cannot provide a comprehensive review of internal and external determinants impacts in the context of socio-economic growth. The final section of current research provides the possible correlation between internal and external socio-economic growth determinants:

$$\begin{cases} I + I_{(E)} + E \rightarrow (IA) \rightarrow SEG, \\ I \rightarrow x, \\ E \rightarrow y, \\ x + y \rightarrow A. \end{cases} \quad (1)$$

To further examine the socio-economic growth (*SEG*) determinants, *SEG* is assumed to be dependent on the innovative activities (*IA*). *IA* is measured as the result of internal determinants (*I*), internal derivatives (*I_E*) and external determinants influences. The internal determinants are nearing to *x*, at the same time the external determinants are nearing to *y*. The sum of *x* and *y* is nearing to *A*, which means the optimal ratio of influences for innovative activities and socio-economic growth.

To determine and better understand the effects of innovative activities determinants on socio-economic growth, three different approaches are defined within the current research (Fig. 2).

(a)- exchangeable approach

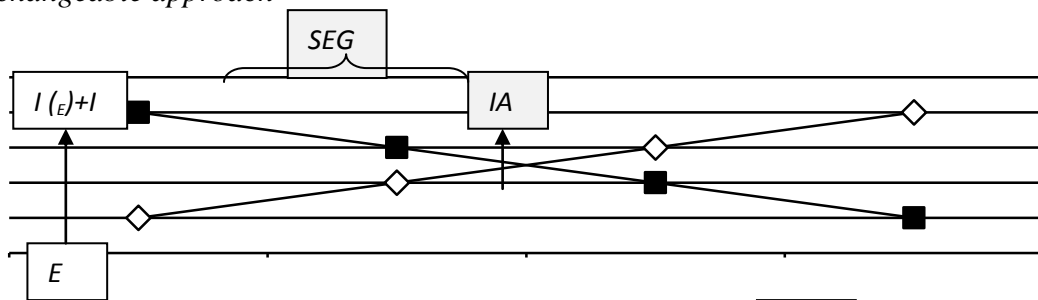

(b)- progressive approach

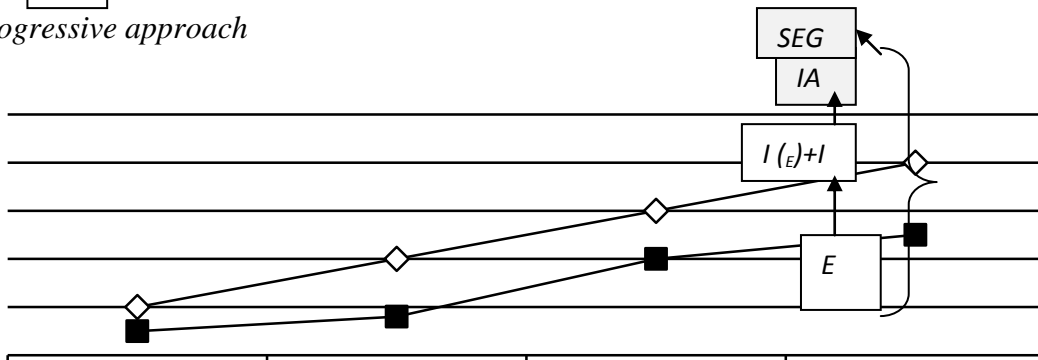

(c)- regressive approach

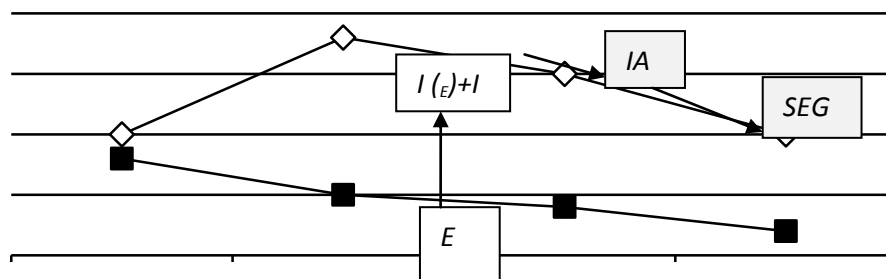

Fig. 2. Determinants of socio-economic growth

Source: considered by authors.

For the purpose of analysis three different approaches are developed. However, in the case of negative results from innovative activities, the above mentioned approaches are not fully realistic. Thus, the combined approach is defined (Fig. 3).

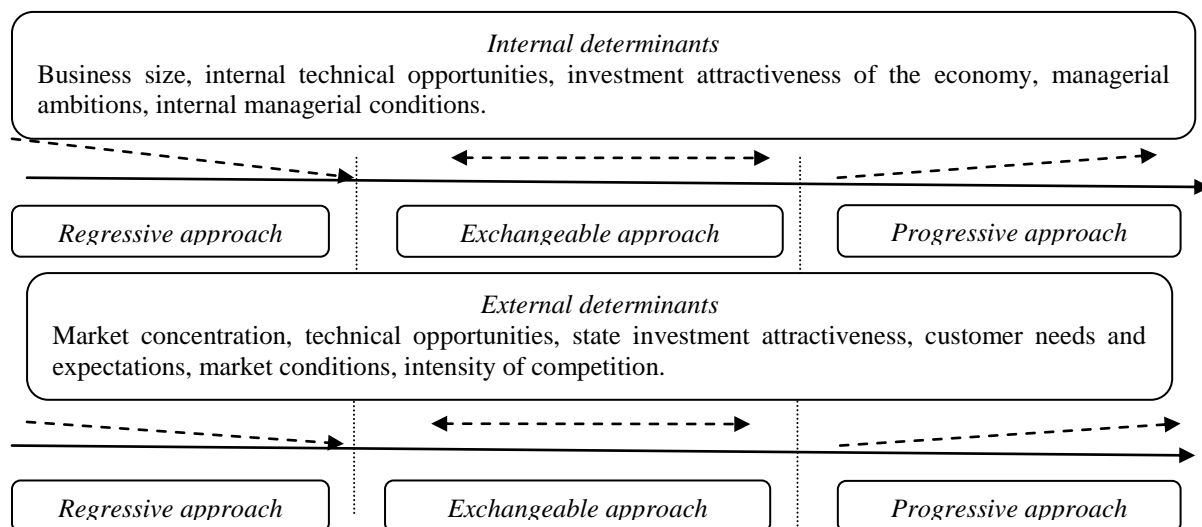

Fig. 3. Combined approach to determinants of innovative activities concerning socio-economic growth

Source: considered by authors

Conclusion. In summary, the current research has shed the light on the different approaches to define the determinants of innovative activities and socio-economic growth. Overall, there seems to be some evidence to indicate that external determinants, including influences on the state and global levels, are among the most important for innovative activities.

Thus, the current research seeks to assess the impact of external determinants at socio-economic growth through their influence on internal (business) determinants. Taken together, these results suggest that there is an association between socio-economic growth and the development of innovative activities determinants. The combination of findings within three different approaches provides some support for the conceptual premise that socio-economic growth tendencies are constantly changed. In particular, these changes are results of different ways of variable nature innovative activities determinants combinations. The internal and external determinants are measured as partly substitutes within the exchangeable approach. The progressive approach describes a situation, when innovative activities are held within the internal and external determinants simultaneous development, which lead to socio-economic growth.

However, due to practical constraints, there are some limitations of our research. Several questions remain unanswered at present.

Further research should be undertaken to investigate the possible innovative activities both on the micro and macro levels. Understanding the influence of determinants on innovative activities and socio-economic growth is important for designing the further innovational tactics and strategy both for entities and the whole national economy. Therefore, our research has the prospects of further development, including the possibility of considering innovative activities as the basic determinant of socio-economic growth and appropriate application of such points views within national economy.

Літератури

1. Schumpeter J. Capitalism, socialism and democracy / J. Schumpeter. — London : Allan &Unwin, 1943.
2. Nee V. A. Theory of Innovation: Market Transition, Property Rights, and Innovative Activity / V. Nee, J. Kang, S. Oppen // Journal of Institutional and Theoretical Economics. — 2010. — Vol. 9. — P. 28—45
3. Oslo manual: The Measurement Of Scientific And Technological Activities. Proposed guidelines for collecting and interpreting technological innovation data // OECD. European Comission. Eurostat. — [N. p.], 2010. — 200 p.
4. Kirshin I. A. Forecasting the Dynamics of an Innovative Cycle / I. A. Kirshin, A. A. Datsyk, & A. Titov // World Applied Sciences. Economics, Management and Finance. — 2013. — Vol. 7. — P. 197—201.

5. Almus M. Growth determinants of start-ups in Eastern Germany: a comparison between innovative and noninnovative firms / M. Almus, E. A. Nerlinger, F. Steil // ZEW Discussion Papers. — 1999. — Vol. 5. — 99 p.
6. Uddenberg A. Growth in established SMEs. Exploring the innovative and ambitious firm / A. Uddenberg. — Linköping : Department of Management and Engineering Linköping University, 2015. — 130 p.
7. Acs Z. J. Patents as a Measure of Innovative Activity / Z. J. Acs, D. B. Audretsch // *Kyklos*. — 1989. — Vol. 42. — Is. 2. — P. 171—180.
8. Unleashing the power of innovation. Global Innovation Survey: Innovation, growth and business strategy [Electronic resource] / PWC. — Available at : <http://www.pwc.com/gx/en/issues/innovation/innovation-survey.html>.
9. Baum J. R. The relationship of enterprising traits, skill, and motivation to subsequent venture growth / J. R. Baum, E. A. Locke // *Journal of Applied Psychology*. — 2004. — Vol. 89 (4). — P. 587—598.
10. Shane S. Entrepreneurial motivation / S. Shane, E. A. Locke, C. J. Collins // *Human Resource Management Review*. — 2003. — Vol. 13. — P. 257—279
11. Delmar F. The effect of small business managers' growth motivation on firm growth: A longitudinal study / F. Delmar, G. Wiklund. — [N. p.] : New Perspectives on Firm Growth, Edward Elgar Publishing Ltd., 2013
12. Utterback J. M. A dynamic model of process and product innovation / J. M. Utterback, W. J. Abernathy // *International Journal of Management Science*. — 1975. — Vol. 3. — № 6. — P. 639—656.
13. Hippel E. The Sources of Innovation / E. Hippel. — New York : Oxford University Press, 1988.
14. Schumpeter J. The theory of economic development / J. Schumpeter. — Cambridge : Harvard College, 1934.
15. Zakić N. External and internal factors affecting the product and business process innovation / N. Zakić, A. Jovanović, M. Stamatović // *FACTA UNIVERSITATIS. Economics and Organization*. — 2008. — Vol. 5. — № 1. — P. 17—29
16. Arrow K. Economic welfare and the allocation of resources for inventions / K. Arrow. — Princeton : Princeton University Press, 1962.
17. Caves R. E. Multinational enterprise and economic analysis / R. E. Caves. — Cambridge : Cambridge University Press, 1982.
18. Higón, D. Exporting and innovation performance: analysis of the annual small business Survey in the UK / D. Higón, A. N. Driffield. — Aston : Economics and Strategy Group, Aston Business School, 2007.
19. Birch D. L. The Job Generation Process / D. L. Birch. — Cambridge, 1979.
20. Arvanitis S. The impact of firm size on innovative activity — an empirical analysis based on swiss firm data / S. Arvanitis // *Small Business Economics*. — 1997. — Vol. 9. — Is. 6. — P. 473—490.
21. Jaffe A. B. Patents, citations, and innovations: A window on the knowledge economy / A. B. Jaffe, M. Trajtenberg. — Cambridge, MA : MIT Press, 2002.
22. Oakey R. P. High Technology Small Firms: A More Realistic Evaluation of Their Growth Potential / R. P. Oakey // *Small Business Dynamics: International, National and Regional Perspectives*. C. Karlsson, B. Johannisson, D. J. Storey (Eds.). — London, 1993.
23. Oakey R. P. New Technology-based Firms in the 1990s. / R. P. Oakey. — London, 1994.
24. Storey D. J. Review of the Empirical Knowledge and an Assessment of Statistical Data on the Economic Importance of New Technology-Based Firms in Europe / D. J. Storey, B. Tether. — Coventry : Warwick Research Institute, 1996.
25. Nerlinger E. Standorte und Entwicklung junger innovativer Unternehmen: Empirische Ergebnisse fuer West-Deutschland / E. Nerlinger. — Baden-Baden : ZEW Wirtschaftsanalysen, 1998. — 27 p.
26. Brissimis S. N. Market power, innovative activity and exchange rate pass-through in the euro area / S. N. Brissimis, T. S. Kosma ; European Central Bank // *Working paper series*. — 2005. — Vol. 5. — P. 31—45.
27. Link A. N. Innovative behavior in small-sized firms / A. N. Link, B. Bozeman // *Small Business Economics*. — 1991. — Vol. 33. — P. 179—84.
28. Mayorova T. High-technology investments as a driver of rural productivity. / T. Mayorova, Z. Domżał, Yu. Gernego, O. Dyba // *Management Theory and Studies for Rural Business and Infrastructure Development*. — 2019. — Vol. 41. — № 1. — P. 25—32.
29. Dyba M. I. Private social investments as a solution for rural development / M. I. Dyba, Yu. O. Gernego // *Management Theory and Studies for Rural Business and Infrastructure Development*. — 2018. — Vol. 40. — № 3. — P. 320—328.

Стаття рекомендована до друку 16.09.2019

© Гернего Ю. О., Дыба О. М.,
Петренко Л. А.

References

1. Schumpeter, J. (1943). *Capitalism, socialism and democracy*. London: Allan & Unwin.
2. Nee, V., Kang, J., & Opper, S. (2010). A Theory of Innovation: Market Transition, Property Rights, and Innovative Activity. *Journal of Institutional and Theoretical Economics*, 9, 28—43.
3. OECD. (2010). *Oslo manual: The Measurement Of Scientific And Technological Activities*. Proposed guidelines for collecting and interpreting technological innovation data. [N. p.]: European Comission. Eurostat.
4. Kirshin, I. A., Datsyk, A. A., & Titov A. V. (2013). Forecasting the Dynamics of an Innovative Cycle. *World Applied Sciences. Economics, Management and Finance*, 27, 197—201.
5. Almus, M., Nerlinger, E. A., & Steil, F. (1999). Growth determinants of start-ups in Eastern Germany: a comparison between innovative and non innovative firms. *ZEW Discussion Papers*, 5.
6. Uddenberg, A. (2015). *Growth in established SMEs. Exploring the innovative and ambitious firm*. Linköping: Department of Management and Engineering Linköping University.
7. Acs, Z. J., & Audretsch, D. B. (1989). Patents as a Measure of Innovative Activity. *Kyklos*, 42, 2, 171—180.
8. PWC. (2016). *Unleashing the power of innovation. Global Innovation Survey: Innovation, growth and business strategy*. Retrieved from <http://www.pwc.com/gx/en/issues/innovation/innovation-survey.html>.
9. Baum, J. R., & Locke, E. A. (2004). The relationship of enterprising traits, skill, and motivation to subsequent venture growth. *Journal of Applied Psychology*, 89 (4), 587—598.
10. Shane, S., Locke, E. A., & Collins, C. J. (2003). Entrepreneurial motivation. *Human Resource Management Review*, 13, 257—279.

11. Delmar, F., & Wiklund, G. (2013). The effect of small business managers' growth motivation on firm growth: A longitudinal study. [N. p.]: New Perspectives on Firm Growth, Edward Elgar Publishing Ltd.
12. Utterback, J. M., & Abernathy, W. J. (1975). A dynamic model of process and product innovation. *International Journal of Management Science, Pergamon Press*, 3, 6, 639—656.
13. Hippel, E. (1988). *The Sources of Innovation*. New York: Oxford University Press.
14. Schumpeter, J. (1934). *The theory of economic development*. Cambridge: Harvard College.
15. Zakić, N., Jovanović, A., & Stamatović, M. (2008). External and internal factors affecting the product and business process innovation. *FACTA UNIVERSITATIS, Series: Economics and Organization*, 5, 1, 17—29.
16. Arrow, K. (1962). *Economic welfare and the allocation of resources for inventions*. Princeton: Princeton University Press.
17. Caves, R. E. (1982). *Multinational enterprise and economic analysis*. Cambridge: Cambridge University Press.
18. Higón, D., & Driffield, A. N. (2007). *Exporting and innovation performance: analysis of the annual small business Survey in the UK*. Aston: Economics and Strategy Group, Aston Business School.
19. Birch, D. L. (1979). *The Job Generation Process*. Cambridge.
20. Arvanitis, S. (1997). The impact of firm size on innovative activity — an empirical analysis based on swiss firm data. *Small Business Economics*, 9, 6, 473—490.
21. Jaffe, A. B., & Trajtenberg, M. (2002). *Patents, citations, and innovations: A window on the knowledge economy*. Cambridge, MA: MIT Press.
22. Oakey, R. P. (1993). High Technology Small Firms: A More Realistic Evaluation of Their Growth Potential. In: *Small Business Dynamics: International, National and Regional Perspectives*. C. Karlsson, B. Johannisson, & D. J. Storey (Eds.). London.
23. Oakey, R. P. (1994). *New Technology-based Firms in the 1990s*. London.
24. Storey, D. J., & Tether, B. (1996). *Review of the Empirical Knowledge and an Assessment of Statistical Data on the Economic Importance of New Technology-Based Firms in Europe*. Coventry: Warwick Research Institute.
25. Nerlinger, E. (1998). *Standorte und Entwicklung junger innovativer Unternehmen: Empirische Ergebnisse fuer West-Deutschland*. Baden-Baden: ZEW Wirtschaftsanalysen.
26. Brissimis, S. N., & Kosma, T. S. (2005). Market power, innovative activity and exchange rate pass-through in the euro area. European Central Bank. *Working paper series*, 531.
27. Link, A. N., & Bozeman, B. (1991). Innovative behavior in small-sized firms. *Small Business Economics*, 33, 179—84.
28. Mayorova, T., Domzał, Z., Gernego, Yu., & Dyba, O. (2019). High-technology investments as a driver of rural productivity. *Management Theory and Studies for Rural Business and Infrastructure Development*, 41, 1, 25—32.
29. Dyba, M. I., & Gernego, Yu. O. (2018). Private social investments as a solution for rural development. *Management Theory and Studies for Rural Business and Infrastructure Development*, 40, 3, 320—328.

The article is recommended for printing 16.09.2019

© Gernego Yu. O., Dyba O. M.,
Petrenko L. A.