

## FRACTIONAL MULTI-PHASE HEREDITARY MATERIALS: MELLIN TRANSFORM AND MULTI-SCALE FRACTANCES

M. Di Paola<sup>1</sup>, F. P. Pinnola<sup>1</sup>, M. Zingales<sup>1,2</sup>

<sup>1</sup>Dipartimento di Ingegneria Civile Ambientale, Aerospaziale, dei Materiali (DICAM),  
Università degli Studi di Palermo,  
Viale delle Scienze, Ed. 8, 90128-Palermo, Italy.  
e-mail: {mario.dipaola, francesco.pinnola, massimiliano.zingales}@unipa.it

<sup>2</sup>Dipartimento di Biomeccanica e Biomateriali,  
Istituto Euro Mediterraneo di Scienza e Tecnologia (I.E.ME.S.T.),  
Via E. Amari 123, 90139-Palermo, Italy.

**Keywords:** hereditary materials, fractional-order operators, multi-phase materials, mechanical models.

**Abstract.** *The rheological features of several complex organic natural tissues such as bones, muscles as well as of complex artificial polymers are well described by power-laws. Indeed, it is well-established that the time-dependence of the stress and the strain in relaxation/creep test may be well captured by power-laws with exponent  $\beta \in [0, 1]$ . In this context a generalization of linear springs and linear dashpots has been introduced in scientific literature in terms of a mechanical device dubbed spring-pot.*

*Recently the authors introduced a mechanical analogue to spring-pot built upon a proper arrangements of springs and dashpots that results in Elasto-Viscous (EV) materials, as  $\beta \in [0, 1/2]$  and Visco-Elastic ones, as  $\beta \in [1/2, 1]$ .*

*In this paper the authors will discuss the rheological description of the presence of multiple material phases that is highlighted by a linear combination of power-laws in the relaxation function  $G(t)$  with different exponents. Such rheological model is represented by a linear combination of fractional derivatives with different order and the inverse relations have been formulated in terms of the complex method Mellin transform.*

*Additionally an alternative representation of direct and inverse relations of multi-phase fractional hereditary materials based on the exact mechanical description of spring-pot element will be discussed in the course of the paper.*

## 1 INTRODUCTION

Mathematical models of rheological features of modern engineered materials has attracted several researchers in the last decades. The model must account, at the macroscopic scale of the mechanical test, for the molecular and /or atomistic bundle motion of the matter that is formidable task. In presence of some geometric hierarchy of the material properties for various observation scales, as that observed in many biological/biomimetic materials, the macroscopic rheological relations depends on power-law functions of the time variables [1, 2].

As far as temporal dependence of the stress-strain rheological evolution is expressed by power-laws the use of Boltzmann superposition principle yields mathematical dependence in terms of fractional order operators.

Fractional-order calculus [3] is considered, usually, as generalization of the well-known differential calculus to real-order values of differentiation/integrations (Riemann-Liouville, Caputo [4], Grünwald-Letnikov, etc.). This consideration led several authors to introduce a mechanical device dubbed spring-pot after Scott-Blair et al. [5, 6] that possessed an intermediate rheological behavior among linear springs and linear dashpots. The mathematical behavior of spring-pot elements is ruled by fractional order operators and several studies have been reported in recent literature about material behavior [7, 8, 9, 10] and system evolutions [11].

Despite the great advantages introduced by the use of fractional-order calculus, the lack of a clear mechanical description of the spring-pot element confined the use of real-order operators to very specific problems in the fields of science and engineering.

Recently the authors introduced fractional order operators as the result of a mechanical fracture made upon linear springs and linear dashpots in a proper assembly [12]. The mechanical scheme restitutes, exactly, fractional order operators and its mechanical capabilities have also been challenged [13].

In this paper the authors aim to study the mechanical/physical behavior of complex materials with multiple physical phases. Such a behavior is described at a macroscopical scale, by the presence of multiple power-laws in the stress-strain relation with different decays. This problem is ruled, in the relaxation test, by a fractional differential equation obtained as a linear combination of fractional derivatives with different exponents. The solution of such differential equations is obtained here resorting to a complex Mellin transform of the displacement history. In this context the solution may be expressed in terms of a series of complex fractional integrals with real order  $\rho$  in the fundamental strip of holomorphism of the kernel function in the complex plane.

Moreover the exact mechanical model of the parallel arrangements of linear spring-pots will be also provided challenging its numerical capabilities.

## 2 THE FRACTIONAL MODEL OF HEREDITARINESS: SINGLE-PHASE AND MULTI-PHASE

In this section we will introduce the fractional model of hereditariness by means of the Boltzmann superposition principle. Let us denote  $G(t)$  the relaxation function of the fractional hereditary material, the stress and strain evolution will be provided as:

$$\sigma(t) = \int_0^t G(t-\bar{t}) d\gamma(\bar{t}) = \int_0^t G(t-\bar{t}) \dot{\gamma}(\bar{t}) d\bar{t} \quad (1)$$

$$\gamma(t) = \int_0^t J(t-\bar{t}) d\sigma(\bar{t}) = \int_0^t J(t-\bar{t}) \dot{\sigma}(\bar{t}) d\bar{t} \quad (2)$$

where  $J(t)$  is the creep function of the material that is related to relaxation  $G(t)$  by means of the Laplace transform as:

$$\hat{G}(s) \hat{J}(s) = \frac{1}{s^2} \quad (3)$$

where we denoted  $s$  the Laplace parameter,  $\hat{G}(s)$  and  $\hat{J}(s)$  are the Laplace transform of the relaxation and the creep function, respectively. In the following two cases of rheological models will be introduced: i) the case of single physical phase of the material and ii) the rheological model of a multi-phase material.

## 2.1 Single-phase fractional hereditary materials (FHM)

Material bundles of several biological/biomimetic materials are made upon self-similar assembly of components and they show a macroscopic rheological relation expressed by power-law as:

$$G(t) = \frac{C(\beta)}{\Gamma(1-\beta)} t^{-\beta} \quad (4)$$

with  $\beta \in [0, 1]$  in order to deal with a physically consistent viscoelastic behavior as shown in previous paper [12]. Material parameters  $C(\beta)$  and  $\beta$  may be evaluated by a best fitting method of experimental data and  $\Gamma(\cdot)$  is the Euler-Gamma function. Since Laplace transform of  $G(t)$  expressed in Eq. (4) reads  $\hat{G}(s) = C(\beta)s^{\beta-1}$ , then, in virtue of Eq. (3), the corresponding Laplace transform of the creep function reads  $\hat{J}(s) = (C(\beta)s^{\beta+1})^{-1}$  whose inverse Laplace transform yields the creep function  $J(t)$  as:

$$J(t) = \frac{1}{C(\beta)\Gamma(1+\beta)} t^\beta \quad (5)$$

As we introduce Eqs. (4) and (5) into Eqs. (1) and (2), respectively, we get:

$$\sigma(t) = C(\beta) \left( {}^C D_{0+}^\beta \gamma \right) (t) \quad (6)$$

$$\gamma(t) = \frac{1}{C(\beta)} \left( I_{0+}^\beta \sigma \right) (t) \quad (7)$$

where symbols  $\left( {}^C D_{0+}^\beta \gamma \right) (t)$  and  $\left( I_{0+}^\beta \sigma \right) (t)$  are, respectively, Caputo fractional derivatives of the strain and Riemann-Liouville fractional integrals of order  $\beta$  that reads:

$$\left( {}^C D_{0+}^\beta \gamma \right) (t) = \frac{1}{\Gamma(1-\beta)} \int_0^t \frac{\dot{\gamma}(\bar{t})}{(t-\bar{t})^\beta} d\bar{t} \quad (8)$$

$$\left( I_{0+}^\beta \sigma \right) (t) = \frac{1}{\Gamma(\beta)} \int_0^t \frac{\sigma(\bar{t})}{(t-\bar{t})^{1-\beta}} d\bar{t} \quad (9)$$

The observation of Eqs. (8) and (9), obtained by assuming for the relaxation function  $G(t)$  a power-law decay, shows that the stress-strain relations involves fractional operators and thus materials obeying to Eqs. (6) and (7) are usually referred to fractional hereditary materials. For systems at rest as  $t = 0$  we may directly obtain Eq. (7) from Eq. (6) by applying Caputo's fractional differentiation to both members of Eq. (7) since the following equality chain holds true  $\sigma(t) = \left( {}^C D_{0+}^\beta I_{0+}^\beta \sigma \right) (t)$ . We may then conclude that, if the stress history is assigned, then the corresponding strain is easily derived from Eq. (7).

## 2.2 The multi-phase rheological model of FHM

Fractional description of hereditary properties of materials provides useful mathematical characterization of stress-strain relationships but, for multi-phase materials, that is in presence of more than one internal length scale and/or more than one dissipative mechanism, a more general expression of the relaxation function  $G(t)$  must be used such as:

$$G(t) = \frac{C(\beta_1)}{\Gamma(1-\beta_1)}t^{-\beta_1} + \frac{C(\beta_2)}{\Gamma(1-\beta_2)}t^{-\beta_2} + \dots + \frac{C(\beta_n)}{\Gamma(1-\beta_n)}t^{-\beta_n} \quad (10)$$

yielding, for Eq. (1) the stress as linear combination of Caputo's type fractional derivatives that reads:

$$\sigma(t) = \sum_{j=1}^n C(\beta_j) \left( {}^C D_{0+}^{\beta_j} \right) (t); \quad 0 \leq \beta_j \leq 1 \quad (11)$$

that represents the extension of Eq. (6) to the case of multi-phase fractional hereditary materials and that may be considered a simple extension. The inverse relation, similar to that reported in Eq. (7), is not trivial as those reported in Eq. (7) since there we obtained the expression for the strain function  $\gamma(t)$  as a Riemann-Liouville fractional integral [14, 15]. This very serious difficulty arises as we use Eq. (3) to obtain the creep function in terms of the relaxation function in Eq. (10) yielding:

$$\hat{J}(s) = \frac{1}{\sum_{j=1}^n C(\beta_j) s^{\beta_j+1}}. \quad (12)$$

Inverse Laplace transform of Eq. (12) may be obtained in series form, for  $n = 2$ , involving Mittag-Leffler function and then a simple  $\sigma - \gamma$  relationships may not be obtained at the best of the authors' knowledge. As an example, in order to understand the cumbersome operators involved in the inverse problem, let us start with the simplest multi-phase problem represented by a parallel arrangement of linear springs and fractional hereditary operator that is represented for  $n = 2, \beta_1 = 0, \beta_2 = \beta$ , yielding:

$$\sigma(t) = E\gamma(t) + C(\beta) \left( {}^C D_{0+}^{\beta} \right) (t) \quad 0 \leq \beta \leq 1 \quad (13)$$

where  $E$  is an arbitrary elastic constant such as the Young modulus. The inverse Laplace transform of the corresponding creep function that reads  $\hat{J}(s) = 1/(E + C(\beta)s^{(\beta+1)})$ , reads:

$$J(t) = \frac{1}{E} \left[ 1 - E_{\beta_2} \left( -\frac{E}{C(\beta_2)} t^{\beta_2} \right) \right] \quad (14)$$

with  $E_{\beta}(\cdot)$  the one-parameter Mittag-Leffler function defined as:

$$E_{\beta} \left( -\frac{E}{C(\beta)} t^{\beta} \right) = \sum_{k=0}^{\infty} \frac{(-E/C(\beta)t^{\beta})^k}{\Gamma(\beta k + 1)} \quad (15)$$

By inserting Eq. (15) in Eq. (14), the creep function reads:

$$J(t) = \frac{1}{E} \left[ 1 - \sum_{k=0}^{\infty} \frac{(-E/C(\beta)t^{\beta})^k}{\Gamma(\beta k + 1)} \right] = -\frac{1}{E} \sum_{k=1}^{\infty} \frac{(-E/C(\beta)t^{\beta_2})^k}{\Gamma(\beta k + 1)} \quad (16)$$



and, as a consequence the strain function  $\gamma(t)$ , according to Eq. (2), is related to the stress  $\sigma(t)$  as follows:

$$\gamma(t) = \frac{1}{E} \left\{ \sigma(t) + \sum_{k=0}^{\infty} \left[ \left( \frac{E}{C(\beta)} \right)^{2k+1} \left( I_{0+}^{(2k+1)\beta} \sigma \right) (t) - \left( \frac{E}{C(\beta)} \right)^{2k} \left( I_{0+}^{2k\beta} \sigma \right) (t) \right] \right\}. \quad (17)$$

Even though this expression is correct from a mathematical perspective, it is not fully satisfactorily from a mechanical point of view. As in fact, by comparing Eq. (10) and Eq. (17) it may be observed that the order of fractional operators involves in Eq. (13) is  $0 \leq \beta \leq 1$ , whereas orders of integral operators in Eq. (17) including a fractional derivative ( $k = 0$ ) and all-orders fractional integrals for  $k > 0$  that is in contrast with limitations in Eq. (13) as  $0 \leq \beta \leq 1$ . A wider discussion about limitations of fractional orders operators for  $0 \leq \beta \leq 1$  may be found in [12], in which an exact mechanical model for viscoelastic materials have been proposed. The relation among the strain functions  $\gamma(t)$  and the stress function  $\sigma(t)$  reported in Eq. (17) in which all the orders of RL fractional integrations appear has been obtained with the aid of the definition of Mittag-Leffler function in Eq. (15) that involves all powers of  $t^k$  for  $k = 0, 1, 2, \dots$

An alternative formulation of the inverse problem may be obtained with the aid of the complex Mellin transform. In order to elucidate the method we can consider that the relaxation function  $G(t)$  be provided in the form:

$$G(t) = \frac{C(\beta_1)}{\Gamma(1-\beta_1)} t^{-\beta_1} + \frac{C(\beta_2)}{\Gamma(1-\beta_2)} t^{-\beta_2}; \quad j = 1, 2, \quad 0 \leq \beta_j \leq 1 \quad (18)$$

whose stress-strain relation is provided by Eq. (12) with  $n = 2$ . The main problem for this case is to obtain an exact expression for the creep function  $J(t)$  with power-law  $\bar{\beta}_j$  and  $0 \leq \bar{\beta}_j \leq 1$ . Laplace transform of the creep function  $J(t)$  for the case under examination is known in analytical form (see Eq. 12), particularized for  $n = 2$ .

Let  $f(s)$  be the complex function of its argument  $s \in \mathbb{C}$  and, in this case, the Mellin transform operator of a complex-valued function is provided as:

$$\mathcal{M}\{f(s); \gamma\} = \int_{\mathcal{L}} f(s) s^{\gamma-1} d\mathcal{L} \quad (19)$$

where  $\gamma = \rho + i\eta$ ,  $\rho, \eta \in \mathbb{R}$ ,  $i$  is the imaginary unity and  $\mathcal{L}$  is a  $C_0$  curve starting at  $s = 0$  and goes to  $\infty$  inside the cone  $S_{\theta_1, \theta_2} = \{s : \theta_1 \leq \arg(s) \leq \theta_2\}$  with  $[\theta_1, \theta_2]$  an interval containing zero and such that  $f(s) = O(s^{-c})$  as  $s \rightarrow 0$  and  $f(s) = O(s^{-d})$  as  $s \rightarrow \infty$  and complex variable  $s \in S_{\theta_1, \theta_2}$  as shown in fig.(1). If  $f(s)$  is analytic in the cone, then Eq. (19) is defined as complex Mellin transform and the integral exists and do not depend on the contour path  $\mathcal{L}$ . In particular, we may select the curve  $\mathcal{L}$  as the real axis and then the following relation holds true:

$$\mathcal{M}\{f(s); \gamma\} = \int_{\mathcal{L}} f(s) s^{\gamma-1} d\mathcal{L} = \int_0^{\infty} f(x) x^{\gamma-1} dx = M_{f+}(\gamma - 1). \quad (20)$$

Inverse Mellin transform restitutes the function in the form:

$$f(s) = \frac{1}{2\pi i} \int_{b-i\infty}^{b+i\infty} M_{f+}(\gamma - 1) s^{-\gamma} d\gamma \quad (21)$$

where parameter  $b$  belongs to the fundamental strip of Mellin transform  $c < b < d$ . It is worth noticing that the value of integral in Eq. (21) does not depend on the particular choice

$b = \Re(\gamma)$  selected, under the condition that  $b$  belongs to the fundamental strip of Mellin transforms. With this results in mind we may now introduce the Mellin transform of  $\hat{J}(s)$  given in Eq. (12) (with  $n = 2$ ) as:

$$\mathcal{M} \left\{ \hat{J}(s); \gamma \right\} = \int_0^\infty \hat{J}(s) s^{\gamma-1} d\rho = \int_0^\infty \frac{s^{\gamma-1}}{C(\beta_1)s^{\beta_1+1} + C(\beta_2)s^{\beta_2+1}} d\rho = M_{j+}(\gamma - 1). \quad (22)$$

Mellin transform of function  $\hat{J}(s)$  may be evaluated in closed-form for  $\beta_1, \beta_2 \in \mathbb{Q}$  (rational numbers). The fundamental strip is provided as  $\beta_1 + 1, \beta_2 + 1$ . Such an example, for  $\beta_1 = 1/3$  and  $\beta_2 = 2/3$ , the fundamental strip is  $4/3 < \Re(\gamma) = \rho < 5/3$  and Mellin transform, in this case reads:

$$\mu \left\{ \frac{1}{C(\beta_1)s^{\beta_1+1} + C(\beta_2)s^{\beta_2+1}}; \gamma \right\} = 3 (C(\beta_1))^{3\gamma-5} (C(\beta_2))^{4-3\gamma} \pi \frac{1}{\sin(3\pi\gamma)}. \quad (23)$$

In virtue of Eq. (21), the inverse Mellin transform is then provided in the form:

$$\hat{J}(s) = \frac{1}{2\pi i} \int_{b-i\infty}^{b+i\infty} M_{j+}(\gamma - 1) s^{-\gamma} d\gamma; \quad \frac{4}{3} < b < \frac{5}{3} \quad (24)$$

By selecting  $\Re(\gamma) = \rho = b$  we may write eq.(24) in the form:

$$\hat{J}(s) = \frac{1}{2\pi} \int_\infty^\infty M_{j+}(\gamma - 1) s^{-\gamma} d\eta; \quad \frac{4}{3} < \rho < \frac{5}{3} \quad (25)$$

Inverse Laplace transform of Eq. (25) yields:

$$J(t) = \mathcal{L}^{-1} \left\{ \hat{J}(s); t \right\} = \frac{1}{2\pi} \int_{-\infty}^{+\infty} M_{j+}(\gamma - 1) \frac{t^{\gamma-1}}{\Gamma(\gamma)} d\eta \quad (26)$$

that becomes, in a discrete form:

$$J(t) \cong \frac{\Delta\eta}{2\pi} \sum_{k=-m}^m M_{j+}(\gamma_k - 1) \frac{t^{\gamma_k-1}}{\Gamma(\gamma_k)}; \quad \gamma_k = \rho + ik\Delta\eta \quad (27)$$

where  $\Delta\eta$  represent the discretization step of the  $\eta$ -axis,  $m\Delta\eta = \bar{\eta}$  is a cut-off value selected in such a way that contribution of term  $n\Delta\eta > m\Delta\eta$  do not produce sensible variations of the sums in eq.(27). Once  $J(t)$  is obtained as in eq.(27) the inverse relationships of the stress-strain relation in eq.(27) yields:

$$\gamma(t) \cong \frac{\Delta\eta}{2\pi} \sum_{k=-m}^m M_{j+}(\gamma_k - 1) (I_{0+}^{\gamma_k} \sigma)(t); \quad \gamma_k = \rho + ik\Delta\eta \quad (28)$$

where  $\Re(\gamma_k)$  belongs to the fundamental strip of Mellin transform. By comparing Eq. (17) and Eq. (28) we observe that, since  $\Re(\gamma_k) = \rho$  and it remains constant as we perform the addition of terms in Eq. (28) that contributes only along the imaginary axis with  $\eta_k$  then the order of fractional operators involved in Eq. (28) does not change. By contrast, all the orders of fractional operators in Eq. (18) are involved in the definition of the inverse relation.

### 3 MECHANICAL ANALOGUES OF FRACTIONAL HEREDITARY MATERIALS: SINGLE AND MULTI-PHASE MATERIAL

In this section we aim to elucidate an alternative representation of fractional hereditary materials based on a mechanical equivalence recently introduced by the authors [12, 13]. In the next section the case of single-phase material behavior will be discussed whereas the case of a multiphase material will be presented in sect. 3.2.

#### 3.1 The mechanical analogues to single-phase FHM

The exact mechanical model of the hereditary materials, that have as stress-strain relation the Eqs. (6) and (7), has been provided in [12] and an extensive description of above model has been given in [13]. In particular two exact mechanical models of fractional hereditary materials have been provided, one model to describe the Elasto-Viscous (EV) materials in which elastic phase prevails and the order  $\beta : 0 \leq \beta \leq 1/2$  and one model to describe the Visco-Elastic (VE) materials in which viscous phase prevails and the order  $\beta : 1/2 \leq \beta \leq 1$ . Both models are shown in Figure 1.

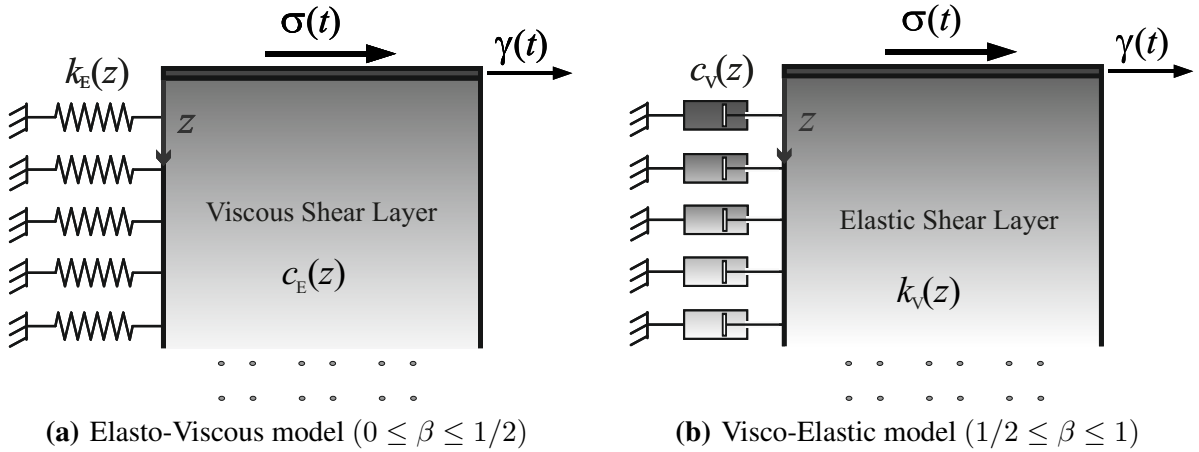

**Figure 1:** Continuous fractional models.

The Elasto-Viscous case ( $0 \leq \beta \leq 1/2$ ) is a massless indefinite viscous shear layer with a viscosity coefficient  $c_E(z)$  resting on a bed of independent springs characterized by an elastic coefficient  $k_E(z)$ . By contrast the Visco-Elastic case ( $1/2 \leq \beta \leq 1$ ) is a massless indefinite elastic shear layer characterized by a shear modulus  $k_V(z)$  resting on a bed of independent viscous dashpots characterized by the viscosity coefficient  $c_V(z)$ . The subscripts  $E$  and  $V$  in  $k(z)$  and  $c(z)$  are introduced in order to distinguish the predominant behavior ( $E$  stands for Elasto-Viscous, while  $V$  stands for Visco-Elastic). Moreover we define  $G_0$  and  $\eta_0$  the reference values of the shear modulus and viscosity coefficient.

As soon as we assume:

$$k_E(z) = \frac{G_0}{\Gamma(1+\alpha)} z^{-\alpha}; \quad c_E(z) = \frac{\eta_0}{\Gamma(1-\alpha)} z^{-\alpha} \quad (29)$$

with  $0 \leq \alpha \leq 1$  and  $\beta = (1 - \alpha)/2$ , and

$$k_V(z) = \frac{G_0}{\Gamma(1-\alpha)} z^{-\alpha}; \quad c_V(z) = \frac{\eta_0}{\Gamma(1+\alpha)} z^{-\alpha} \quad (30)$$

with  $\beta = (1 + \alpha)/2$ , the stress  $\sigma(t)$  at the upper lamina and  $\gamma(t)$  the corresponding normalized displacement (that is the corresponding strain) reverts to a fractional law expressed in Eq. (7).

The governing equation for  $0 \leq \beta \leq 1/2$  of the mechanical model depicted in Figure 1(a) is

$$\frac{\partial}{\partial z} \left[ c_E(z) \frac{\partial \dot{\gamma}(z, t)}{\partial z} \right] = k_E(z) \gamma(z, t) \quad (31)$$

the constitutive law obtained for  $\gamma(0, t) = \gamma(t)$  is that obtained in Eq. (7) provided the coefficient  $C(\beta) = C_E(\beta)$  in the stress-strain relation is given as

$$C_E(\beta) = \frac{G_0 \Gamma(\beta) 2^{2\beta-1}}{\Gamma(2-2\beta) \Gamma(1-\beta)}; \quad 0 \leq \beta \leq 1/2 \quad (32)$$

with  $\tau_E(\alpha) = -\eta_0 \Gamma(\alpha) / \Gamma(-\alpha) G_0$  and  $\beta = (1 - \alpha)/2$ .

The equilibrium equation of the continuous model depicted in Figure 1(b) is written as:

$$\frac{\partial}{\partial z} \left[ k_V(z) \frac{\partial \gamma(z, t)}{\partial z} \right] = c_V(z) \dot{\gamma}(z, t) \quad (33)$$

the solution of such differential equation for  $z \rightarrow 0$  shows that the stress  $\sigma(t)$  at the top is related to the normalized displacement  $\gamma(t)$  by means of a fractional derivate of order  $\beta = (1 + \alpha)/2$ . The coefficient  $C(\beta) = C_V(\beta)$  in the stress-strain relation reads

$$C_V(\beta) = \frac{G_0 \Gamma(1-\beta) 2^{1-2\beta}}{\Gamma(2-2\beta) \Gamma(\beta)} (\tau_V(\alpha))^\beta; \quad 1/2 \leq \beta \leq 1 \quad (34)$$

with  $\tau_V(\alpha) = -\eta_0 \Gamma(-\alpha) / \Gamma(\alpha) G_0$  and  $\beta = (1 + \alpha)/2$ .

These models can be discretized in the form shown in Figure 2. In this way, they are easy to deal with to perform numerical simulations. In particular by introducing a discretization of the

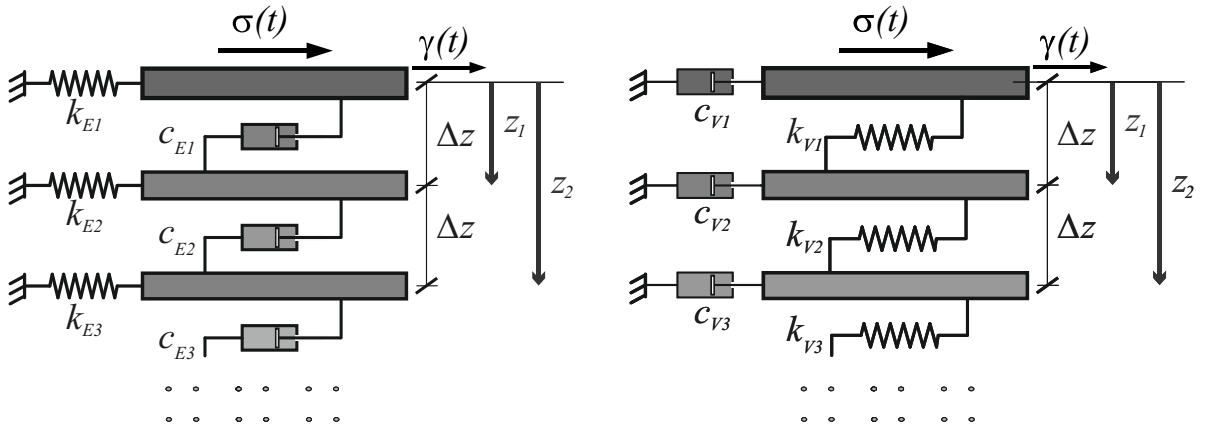

(a) Discretized counterpart of the continuous model Figure 1(a): EV column.

(b) Discretized counterpart of the continuous model Figure 1(b): VE column.

**Figure 2:** Discretized fractional models.

$z$ -axis as  $z_j = j \Delta z$  into to the governing equation of the EV material in Eq. (31) yields a finite difference equation of the form:

$$\frac{\Delta}{\Delta z} \left[ c_E(z_j) \frac{\Delta \dot{\gamma}(z_j, t)}{\Delta z} \right] = k_E(z_j) \gamma(z_j, t) \quad (35)$$

so that, denoting  $k_{Ej} = k_E(z_j)\Delta z$  and  $c_{Ej} = c_E(z_j)/\Delta z$  the continuous model is discretized into a dynamical model constituted by massless shear layers, with horizontal degrees of freedom  $\gamma(z_j, t) = \gamma_j(t)$ , that are mutually interconnected by linear dashpots with viscosity coefficients  $c_{Ej}$  and resting on a bed of independent linear springs  $k_{Ej}$ .

Whereas the discretized counterpart of VE mechanical model we have the following finite difference equation obtained by Eq. (33):

$$\frac{\Delta}{\Delta z} \left[ k_V(z_j) \frac{\Delta \gamma(z_j, t)}{\Delta z} \right] = c_V(z_j) \dot{\gamma}(z_j, t) \quad (36)$$

that corresponds to a discretized mechanical representation of fractional derivatives. The mechanical model is represented by a set of massless shear layers with state variables  $\gamma(z_j, t) = \gamma_j(t)$  that are mutually interconnected by linear springs with stiffness  $k_{Vj} = k_V(z_j, t)/\Delta z$  resting on a bed of independent linear dashpots with viscosity coefficient  $c_{Vj} = c_V(z_j, t)\Delta z$ .

### 3.2 The mechanical model of multi-phase FHM

In order to overcome the above mechanical paradox in which appear many fractional operators that have no mechanical meaning, we can take advantage of the mechanical models introduced in [12]. In particular the exact mechanical models for the differential equation in Eq. (13) are two, that depends on the type of fractional phase (EV or VE). The discretized forms of the two exact mechanical models are shown in Figure 3.

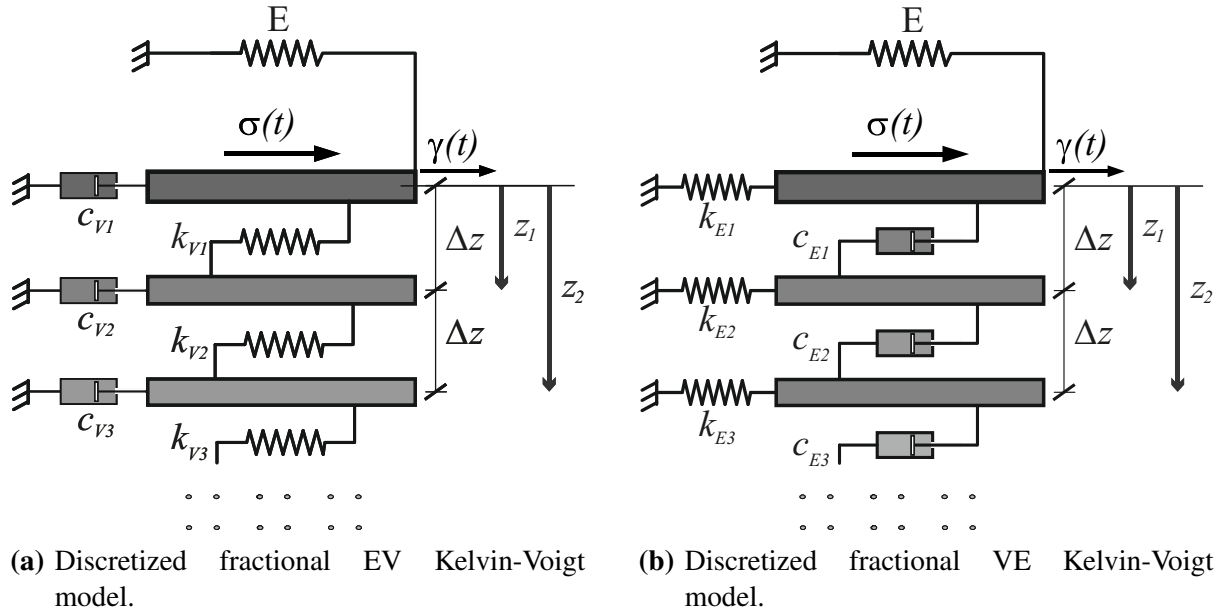

**Figure 3:** Discretized fractional multi-phase models.

In order to find the stress-strain relation, by using the discretized mechanical models in figure, it is enough conduct modal analysis as in [13, 16]. This method is not reported for brevity sake's but the results in terms of inverse relation corresponding to uniform applied load, namely the creep function of multi-phase fractional hereditariness have been reported in Figure 4. In particular, the approximate solutions, which are obtained with  $\sigma(t) = U(t)$ ,  $G_0 = \eta_0 = 2$ ,  $\tilde{K} = 20 G_0$ ,  $n = 750$ ,  $\Delta z = 0.05$  and different values of  $\beta = 0.4, 0.5, 0.6$ , have been contrasted with the exact solution reported in Eq. (14).

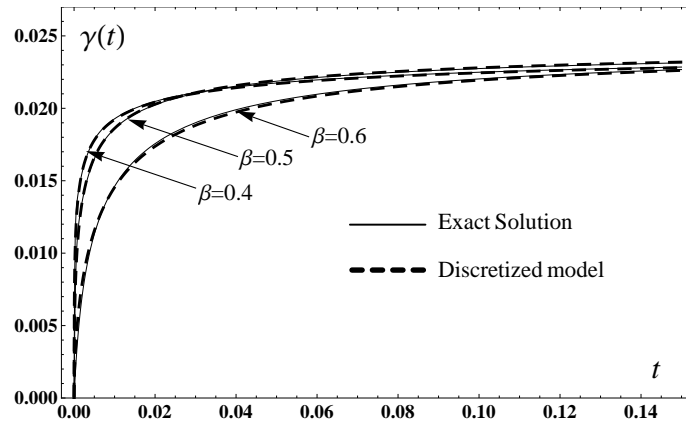

**Figure 4:** Creep test of EV and VE Kelvin-Voigt model: comparison between the exact and approximate solution.

#### 4 CONCLUSIONS

In this paper the authors introduced some alternative mathematical and mechanical representation of fractional multi-phase materials. These models are required to deal with rheological material behavior, at macroscales, that involves multiple time-decay of the relaxation function as in presence of different microscopic length scale as well as in case of different dissipation mechanisms. The presence of a two-phase rheological model is detected as, in the relaxation function, more than one exponent of time-decay of the stress is involved. The rheological model is described, then, by the linear combination of two fractional derivatives with different decays and, in the inverse relation, the strain field is expressed by a series expansion in terms of fractional integrals with increasing order that are meaningless from a mechanical perspective. In this paper the authors introduced the inverse relation of a fractional multi-phase material in terms of the complex Mellin transform yielding a series expansion in the complex argument with real part in the fundamental strip of holomorphism of the transformed function. An alternative mechanical description of the multi-phase mechanical model has been also provided in terms of a recently proposed mechanical analogue of fractional hereditariness that reconstitutes the power-law decay to the response of a mechanical fractance made upon linear springs and linear dashpots with variable coefficients.

#### REFERENCES

- [1] Nutting, P. G. (1921). A new general law of deformation. *Journal of the Franklin Institute*, 191:679–685.
- [2] Di Paola, M., Pirrotta, A., Valenza, A. (2011). Visco-elastic behavior through fractional calculus: An easier method for best fitting experimental results. *Mechanics of Materials*, 43:799–806.
- [3] Podlubny, I. (1999). *Fractional Differential Equations*. Academic Press, San Diego.
- [4] Caputo, M. (1969). *Elasticità e Dissipazione*. Zanichelli, Bologna.
- [5] Scott Blair, G. W. (1947). The role of psychophysics in rheology. *Journal of Colloid Sciences*, 2:21–32.

- [6] Slonimsky, G. L. (1961). On the law of deformation of highly elastic polymeric bodies. *Dokl. Akad. Nauk SSSR*, 2:343–346 (in Russian).
- [7] Heymans, N., Bauwens, J. C. (1994). Fractal rheological models and fractional differential equations for viscoelastic behavior. *Rheologica Acta*, 33:210–219.
- [8] Schiessel, H., Metzeler, R., Blumen, A., Nonnenmacher, T. F. (1995). Generalized viscoelastic models: their fractional equations with solutions. *Journal of Physics A: Mathematical and General*, 28:6567–6584.
- [9] Chechkin, A. V., Gonchar, V. Yu., Gorenflo, R., Korabel, N., Sokolov, I. M. (2008). Generalized fractional diffusion equations for accelerating subdiffusion and truncated Levy flights. *Physical Review E*, 78:741–748.
- [10] Tarasov, V. E. (2010). *Fractional Dynamics: Applications of Fractional Calculus to Dynamics of Particles, Fields and Media*. Springer.
- [11] Mainardi, F. (2010). *Fractional Calculus and Waves in Linear Viscoelasticity*. Imperial College Press-World Scientific, London.
- [12] Di Paola, M., Zingales, M. (2012). Exact mechanical models of fractional hereditary materials. *Journal of Rheology*, article in press.
- [13] Di Paola, M., Pinnola, F. P., Zingales, M. (2012). A discrete mechanical model of fractional hereditary materials. *Meccanica: An International Journal of Theoretical and Applied Mechanics*, submitted.
- [14] Suarez, L. E., Shokooh, A. (1995). Response of systems with damping materials modeled using fractional calculus. *Applied Mechanics Reviews*, 48:S118–S126.
- [15] Rossikhin, Yu. A., Shitnikova, M. V. (2001). A new method for solving dynamic problems of fractional derivative viscoelasticity. *International Journal of Engineering Science*, 39: 149–176.
- [16] Di Paola, M., Pinnola, F. P., Zingales, M. (2012). Fractional differential equations of multi-phase hereditary materials and exact mechanical models. *FDA 2012: The Fifth Symposium on Fractional Differentiation and Its Applications*, May 14-17 2012, Hohai University, Nanjing, China.