



**UNIVERSITÀ DEGLI STUDI DI PALERMO**

**Dottorato di Ricerca in Medicina Molecolare**

Dipartimento di Biopatologia e Biotecnologie Mediche e Forensi

Settore Scientifico Disciplinare MED/04 Patologia Generale

**MOLECULAR AND CELLULAR APPROACHES  
IN TRANSFUSION MEDICINE**

**DOTTORE**

**Dr. Claudia Maria Rizzo**

**COORDINATORE**

**PROF. CALOGERO CARUSO**

**TUTOR**

**PROF. CALOGERO CARUSO**

*"(...) Practicing transfusion is simply imitated Nature that, to nourish the fetus in the womb, make a continuous mother blood transfusion in the body of the baby through the umbilical vein"*

Jean-Baptiste Denis (1620-1704)

## TABLE OF CONTENTS

<i>Abstract of papers produced during PhD and Post graduated course</i>	3
<i>List of abbreviations</i>	15
<i>List of Figures and Tables</i>	16
<i>1. Introduction</i>	17
<i>1.1. History of transfusion medicine</i>	17
<i>1.2. Contemporary transfusion medicine: the last 20 years of discovery</i>	33
<i>1.2.1. Therapeutic Apheresis</i>	34
<i>1.2.2. Regenerative Medicine</i>	42
<i>1.2.3. Stem cells</i>	45
<i>1.2.4. Blood groups and molecular biology</i>	49
<i>2. Aim of the thesis</i>	62
<i>3. Thrombotic thrombocytopenic purpura: a review of the literature in the light of our experience with plasma exchange</i>	68
<i>4. The role of platelet gel in osteoarticular injuries of young and old patients</i>	81
<i>5. Possible role of ABO system in age-related diseases and longevity: a narrative review</i>	93
<i>6. Weak D and partial D: our experience in daily activity</i>	101
<i>7. Genetic Variation in Human Leukocyte Antigen and Susceptibility to Acute Myeloid Leukemia</i>	104
<i>8. Discussion and conclusion</i>	107
<i>Reference</i>	114

## ABSTRACT OF PAPERS

Produced during PhD and Post graduated course

---

1. **Rizzo C.**, Vetro R., Vetro A., Mantia R., Iovane A., Di Gesù M., Vasto S., Di Noto L.,Mazzola G., Caruso C. *The role of platelet gel in osteoarticular injuries of young and old patients*. Immunity and Aging 2014, 11:21.

### ABSTRACT

Background: The use of autologous platelet gel in orthopedics is effective in accelerating the healing process of osteochondral, muscle, tendon and ligament lesions. The aim of our study was to verify whether the variability in response to infiltration with platelet gel was dependent on the underlying disease treated, sex and age of the patients. During four years, 140 patients have been treated for musculoskeletal injuries by infiltration of gel platelet and lysate platelet obtained from autologous thrombin, with echo-ultrasound guided. The response to treatment was assessed at different time points T0, T1, T2 with respect to pain estimation (VAS), joint mobility (ROM scale) and echo-ultrasound evaluation. This data collection has allowed classifying the response to treated lesions in three categories: NR (no response), PR (partial response), CR (complete response). Results: The data here reported showed that the ability to physical recovery response is evident in tendon injuries, while the large joints injuries gave a poor response. Almost all patients showed a significant pain relief after the first infiltration, but in terms of echo-ultrasound evaluation and tissue repair, only the muscle and tendon injuries showed hyper echoic areas, signs or evidences of repair. Concerning the correlation between response to infiltration with platelet gel and gender/age of the patients, the clinical results appear not influenced by the age and the gender of the patient. Discussion: Our data indicate that, pain relief and ability to physical recovery of muscles, tendons and ligaments depend on tissue repair clearly visible by echo ultrasound evaluation.

On the other hand tissue repair seems not occur in the large joints (hip and knee) where arthritis and /or corrosion of articular cartilage cannot be repaired and the only relief is exclusively linked to the reduction of periarticular inflammation (reduction of the inflammatory leakage and signs).

2. **Rizzo C.**, Caruso C, Vasto S. *Possible role of ABO system in age-related diseases and longevity: a narrative review*. Immunity & Ageing 2014, 11:16.

#### ABSTRACT.

ABO blood group antigens are expressed either on the surface of red blood cells either on a variety of other cells. Based on the available knowledge of the genes involved in their biosynthesis and their tissue distribution, their polymorphism has been suggested to provide intra species diversity allowing to cope with diverse and rapidly evolving pathogens. Accordingly, the different prevalence of ABO group genotypes among the populations has been demonstrated to be driven by malaria selection. In the similar manner, a particular ABO blood group may contribute to favor life-extension via biological mechanisms important for surviving or eluding serious disease. In this review, we will suggest the possible association of ABO group with age-related diseases and longevity taking into account the biological role of the ABO glycosyltransferases on some inflammatory mediators as adhesion molecules.

3. **Rizzo C.**, Accardi G., Caruso C. *Genetic Variation in Human Leukocyte Antigen and Susceptibility to Acute Myeloid Leukemia*. Acta Haematol. 2014 Sep 27;133(2):162-163

#### EXCERPTA

In this issue of Acta Haematologica , the authors report the association between the human major histocompatibility complex (MHC) human leukocyte

antigen (HLA)-C3 and acute myeloid leukemia in the Korean population, confirming previous studies on the association between HLA-C and acute myeloid leukemia [1] . Following the demonstration by Lilly et al. [2] in 1964 of the increased risk of spontaneous or virus-induced leukemia in congenic mice with the H-2K (the MHC in mice), it is now over 40 years since the first associations between particular HLAs and leukemia and lymphoma diseases were described. These include a cross-reactive group of HLA-B and Hodgkin's disease, HLA-A2 and acute lymphocytic leukemia (ALL) [3] . Over time, many studies on the association between HLA and the different kinds of leukemia have been performed showing contrasting results [3] . Following these pioneering studies, a broad spectrum of immune-mediated diseases, certain malignancies, longevity, infectious diseases, and adverse reactions to some drugs have been shown to be associated with allelic variants of HLA [4, 5] . So far, there appear to be no striking leukemia genetic susceptibility loci in HLA similar in nature and magnitude to those seen for autoimmune and infectious diseases. However, mounting evidence suggests that more modestly associated susceptibility loci showing population and type may exist [1, 3] . Nevertheless, the clear identification of a causative role for the HLA polymorphism in the pathogenesis of HLA-associated leukemia remains the exception rather than the rule. Advances in the understanding of MHC biological functions will enable comprehensive and definitive studies for evaluating the role of HLA in leukemia

4. **Rizzo C**, Rizzo S, Scirè E, Di Bona D, Ingrassia C, Franco G, Bono R, Quintini G, Caruso C. *Thrombotic thrombocytopenic purpura: a review of the literature in the light of our experience with plasma exchange*. Blood Transfusion. 2012 Jun 27:1-12.

EXCERPTA

Thrombotic thrombocytopenic purpura (TTP), a disease characterized by disseminated thrombotic microangiopathy associated with hemolytic microangiopathic anemia, was described for the first time by Eli Moscowitz in 1925 as an "acute febrile pleiochromic anemia with hyaline thrombosis of the terminal arterioles and capillaries"<sup>1</sup>. The disease is now better understood from a pathophysiological point of view even though its rarity (annual incidence of 11.3 cases per 1,000,000 population)<sup>2</sup> and the lack of specificity of the signs, symptoms and laboratory findings make its management difficult. The symptoms, as stated, are non-specific: fever, renal dysfunction (to the point of acute renal failure in some cases), fluctuating neurological disorders (mild headache, onset of behavioral anomalies, transient sensory and motor deficits, coma), possible ischemic gastrointestinal complications (abdominal pain) and retinal detachment. More than 35% of patients do not have neurological symptoms at onset; fever and renal dysfunction are present in only a small minority of cases. The diagnosis can, therefore, be made in the presence of a microangiopathic hemolytic anemia (with schistocytes in a peripheral blood smear), thrombocytopenia (from platelet consumption) and increased levels of lactate dehydrogenase (LDH) not due to other identifiable causes<sup>3,4</sup>.

5. Vasto S, Scapagnini G, **Rizzo C**, Monastero R, Marchese A, Caruso C. *Mediterranean diet and longevity in Sicily: survey in a Sicani Mountains population*. Rejuvenation Res. 2012 Apr;15(2):184-8.

#### ABSTRACT

Over the past several years, increasing evidence suggests that the Mediterranean diet has a beneficial influence on several age-related diseases, showing protective effect on health and longevity. Mediterranean diet refers to dietary patterns found in olive-growing regions of the Mediterranean countries. Previous data reported that in Sicily, Italy, the largest Mediterranean island,

there are some mountainous regions where there is a high frequency of male centenarians with respect to the Italian average. The aim of the present study was to characterize centenarians living in one of this region, the Sicani Mountains, located in western Sicily. Present data shows that in this zone there are more centenarians with respect to the Italian average. In fact, in the three villages of the Sicani Mountains, there were 15 people ranging from 100 to 107 years old, of the total population of about 10,000 inhabitants. This centenarian number was more than six-fold higher the national average (15.0 vs. 2.4/10,000); the female/male ratio was 1.5 in the study area, whereas the national ratio is 4.54. Centenarians living in these villages had anthropometric measurements within normal limits and moderate sensory disability without any sign of age-related diseases, including cognitive deterioration and dementia. In addition, their clinical chemistry profile was similar to young controls and far better than that of old controls. Unequivocally, their nutritional assessment showed a high adherence to the Mediterranean nutritional profile, with low glycemic index food consumed. Overall, close adherence to Mediterranean diet seems to play a key role in age-related disease prevention and in attaining longevity.

6. Vasto S, **Rizzo C**, Caruso C. *Centenarians and diet: what they eat in the Western part of Sicily*. *Immunity& Ageing*. 2012 Apr 23;9(1):10.

ABSTRACT.

This paper pays attention to the modifiable lifestyle factors such as diet and nutrition that might influence life extension and successful ageing. Previous data reported that in Sicily, the biggest Mediterranean island, there are some places where there is a high frequency of male centenarians with respect to the Italian average. The present data show that in Sicani Mountain zone there are more centenarians with respect to the Italian average. In fact, in five villages of Sicani Mountains, there were 19 people with an age range of 100–107 years old from a



total population of 18,328 inhabitants. So, the centenarian number was 4.32-fold higher than the national average (10.37 vs. 2.4/10,000); the female/male ratio was 1.1:1 in the study area, while the national ratio is 4.54:1. Unequivocally, their nutritional assessment showed a high adherence to the Mediterranean nutritional profile with low glycemic index food consumed. To reach successful ageing it is advisable to follow a diet with low quantity of saturated fat and high amount of fruits and vegetables rich in phytochemicals.

7. Di Bona D, **Rizzo C**, Bonaventura G, Candore G, Caruso C. *Association Between Interleukin-10 Polymorphisms and Alzheimer's Disease: A Systematic Review and Meta-Analysis*. J Alzheimers Dis. 2012 Feb 22.

#### ABSTRACT.

It has been hypothesized that polymorphisms of interleukin (IL)-10 genes affect the risk of developing late onset Alzheimer's disease (AD). However, results of different studies are often inconsistent. Our aim was to investigate by meta-analysis the association of the common polymorphisms comprehensively defining the genetic variability of the IL-10 gene with AD risk. Fifteen studies investigating the association between IL-10 polymorphisms (-1082, -819, -592) and AD were found and analyzed. The model-free approach was applied to meta-analyze these case-control genetic association studies. Available data suggested an association between -1082 polymorphism and AD risk with a marginal statistical significance (GG versus AG/AA: pooled odds ratio [OR]: 0.82, 95% confidence interval CI: 0.65–1.02) and evidence of a moderate degree of between-study heterogeneity ( $\chi^2= 27.13$ , d.f. = 13,  $p = 0.01$ ,  $I^2= 52\%$ ). For the -819 and -592 polymorphisms, we did not find an association with AD, but significant between-study heterogeneity made genotype data pooling unacceptable. Analysis by IL-10 haplotype showed that the -1082G/-819C/-592C haplotype is associated with a lower risk of AD, although with a marginal

statistical significance, probably due to the low number of studies included (GCC versus other genotypes: OR: 0.61, 95% CI: 0.32–1.15; I2 : 85%). Current findings suggest a possible association between -1082 A>G polymorphism and the risk of developing AD; this effect is more evident in the oldest patients. The high degree of between-study heterogeneity, due to several underpowered studies and to other methodological problems of individual studies underlies the need for further methodologically adequate studies.

8. **Rizzo C**, Castiglia L, Arena E, Gangi S, Mazzola G, Caruso C, Vasto S. *Weak D and partial D: our experience in daily activity*. Blood Transfus. 2012 Feb 13:1-2

#### EXCERPTA

Dear Sir,

The RH genes RHD and RHCE encode two proteins that represent the clinically most important blood group system defined by the sequences of red cell membrane proteins. RHD and RHCE, encoding the Rh proteins (D and Cc/Ee, respectively), are organised in tandem on chromosome 1p34-p36 and probably derived from duplication of a common ancestral gene. Many RH genes carry point mutations, or have rearrangements and exchanges between RHD and RHCE which result from gene conversion events. RHCE encode hybrid proteins that have RhCE-specific amino acids in RhD, or RhD-specific residues in RhCE. These might generate new antigens in the Rh blood group system, and alter or weaken expression of the conventional antigens<sup>1,2</sup>

9. Vasto S, Caruso C, Castiglia L, Duro G, Monastero R, **Rizzo C**. *Blood group does not appear to affect longevity a pilot study in centenarians from Western Sicily*. Biogerontology. 2011 Jul 16.

#### ABSTRACT

Centenarians are the best example of extreme human longevity, and they represent a selected population in which the appearance of major age-related diseases, such as cancer, and cardiovascular diseases among others, has been consistently delayed or escaped. The study of the long-lived individual genetic profile has the purpose to possibly identify the genes and the allelic variations influencing extended life expectancy, hence considering them as biomarkers of age-related diseases onset and development. The present study shows no significant differences between allelic variations of ABO blood groups among a group of centenarians from Western Sicily.

10. Candore G, Bulati M, Caruso C, Castiglia L, Colonna-Romano G, Di Bona D, Duro G, Lio D, Matranga D, Pellicanò M, **Rizzo C**, Scapagnini G, Vasto S. *Inflammation, cytokines, immune response, apolipoprotein E, cholesterol, and oxidative stress in Alzheimer disease: therapeutic implications.* Rejuvenation Res. 2010 Apr-Jun;13(2-3):301-13

#### ABSTRACT.

Alzheimer disease (AD) is a heterogeneous and progressive neurodegenerative disease, which in Western society mainly accounts for senile dementia. Today many countries have rising aging populations and are facing an increased prevalence of age-related diseases, such as AD, with increasing health-care costs. Understanding the pathophysiology process of AD plays a prominent role in new strategies for extending the health of the elderly population. Considering the future epidemic of AD, prevention and treatment are important goals of ongoing research. However, a better understanding of AD pathophysiology must be accomplished to make this objective feasible. In this paper, we review some hot topics concerning AD pathophysiology that have an important impact on therapeutic perspectives. Hence, we have focused our attention on inflammation, cytokines, immune response, apolipoprotein E

(APOE), cholesterol, oxidative stress, as well as exploring the related therapeutic possibilities, i.e., non steroidal anti inflammatory drugs, cytokine blocking antibodies, immunotherapy, diet, and curcumin.

11. Cevenini E, Caruso C, Candore G, Capri M, Nuzzo D, Duro G, **Rizzo C**, Colonna-Romano G, Lio D, Di Carlo D, Palmas MG, Scurti M, Pini E, Franceschi C, Vasto S. *Age-related inflammation: the contribution of different organs, tissues and systems. How to face it for therapeutic approaches*. *Curr Pharm Des*. 2010;16(6):609-18.

#### ABSTRACT.

A typical feature of ageing is a chronic, low-grade inflammation characterized by a general increase in the production of pro-inflammatory cytokines and inflammatory markers (“inflamm-ageing”). This status may slowly damage one or several organs, especially when unfavorable genetic polymorphisms and epigenetic alterations are concomitant, leading to an increased risk of frailty together with the onset of age-related chronic diseases. The contribution of different tissues (adipose tissue, muscle), organs (brain, liver), immune system and ecosystems (gut microbiota) to age-related inflammation (“inflamm-ageing”) will be discussed in this review in the context of its onset/progression leading to site-restricted and systemic effects. Moreover, some of the possible strategies and therapies to counteract the different sources of molecular mediators which lead to the age-related inflammatory phenotype will be presented.

12. Vasto S, Scapagnini G, Bulati M, Candore G, Castiglia L, Colonna-Romano G, Lio D, Nuzzo D, Pellicanò M, **Rizzo C**, Ferrara N, Caruso C. *Biomarkes of aging*. *Front Biosci (Schol Ed)*. 2010 Jan 1;2:392-402.

#### ABSTRACT

Aging is a complex process that negatively impacts the development of the different systems and its ability to function. Moreover, the Aging rate in humans is not the same, principally due to genetic heterogeneity and environmental factors. The aging rate is measured as the decline of functional capacity and stress resistance. Therefore, several attempts have been made to analyse the individual age, ( so-called biological age) compared to chronological age. The biomarkers of aging are age-related body function or composition, these markers aim to assess the biological age and predict the onset of age-related diseases and/or residual lifetime. Such biomarkers should help in one hand to characterize the biological age and on the other hand to identify individuals at high risk of developing age-associated diseases or disabilities. Unfortunately, most of the markers under discussion are related to age-related diseases rather than to age, so none of these markers discussed in literature is a true biomarker of aging. Hence, we discuss some disease-related biomarkers useful for a better understanding of aging and the development of new strategies to counteract it, essential for improving the quality of life of the elderly population.

13. Iemolo F, Duro G, **Rizzo C**, Castiglia L, Hachinski V, Caruso C *Pathophysiology of vascular dementia*. Immun Ageing. 2009 Nov 6;6:13.

#### ABSTRACT

The concept of Vascular Dementia (VaD) has been recognized for over a century, but its definition and diagnostic criteria remain unclear. Conventional definitions identify the patients too late, miss subjects with cognitive impairment short of dementia, and emphasize consequences rather than causes, the true bases for treatment and prevention. We should throw out current diagnostic categories and describe cognitive impairment clinically and according to commonly agreed instruments that document the demographic data in a standardized manner and undertake a systematic effort to identify the

underlying aetiology in each case. Increased effort should be targeted towards the concept of and criteria for Vascular Cognitive Impairment and Post-Stroke Dementia as well as for genetic factors involved, especially as these categories hold promise for early prevention and treatment.

14. De Luca G, Santagostino M, Secco GG, Cassetti E, Giuliani L, Franchi E, Coppo L, Iorio S, Venegoni L, Rondano E, Dell'Era G, **Rizzo C**, Pergolini P, Monaco F, Bellomo G, Marino P *Mean platelet volume and the extent of coronary artery disease: results from a large prospective study*. *Atherosclerosis*. 2009 Sep;206(1):292-7.

#### ABSTRACT.

Background: Platelets play a central role in the pathogenesis of coronary artery disease. Mean platelet volume (MPV) is an indicator of platelet activation, and has been demonstrated to be correlated with platelet reactivity. The aim of the current study was to investigate whether mean platelet volume is associated with the extent of coronary artery disease. Methods: We measured MPV in 1411 consecutive patients undergoing coronary angiography. All angiograms were analyzed by two investigators blinded of clinical data. Significant coronary artery disease was defined as stenosis >50% in at least 1 coronary vessel. We additionally measured Carotid Intima-Media Thickness (IMT) in 359 patients. The relationship between MPV and platelet aggregation was evaluated by PFA-100 in 50 consecutive patients who were not taken any antiplatelet therapy, and in a cohort of patients who were on aspirin by PFA-100 (n = 161) and Multiplate (n = 94). Results: Patients were divided into three groups according to tertiles of MPV. Patients with higher MPV were slightly older (p = 0.038), with larger prevalence of diabetes (p < 0.0001), hypertension (p = 0.008), previous CVA (p = 0.041), less often with stable angina (p = 0.043) and family history of CAD (p = 0.011), more often on statins (p = 0.012), and diuretics (p = 0.007). MPV was

associated with baseline glycaemia ( $p < 0.0001$ ) and red blood cell count ( $p = 0.056$ ), but inversely related to platelet count ( $p < 0.0001$ ). MPV was not associated with the extent coronary artery disease ( $p = 0.71$ ) and carotid IMT ( $p = 0.9$ ). No relationship was found between MPV and platelet aggregation. Conclusion: This study showed that MPV is not related to platelet aggregation, the extent of coronary artery disease and carotid IMT. Thus, this parameter cannot be considered as a marker of platelet reactivity or a risk factor for coronary artery disease.

## **LIST OF ABBREVIATIONS**

---

<b>RBC</b>	Red Blood cells
<b>PEX</b>	Plasma Exchange
<b>ASFA</b>	American Society for Apheresis
<b>RhAG</b>	Rh-associated glycoprotein
<b>HDFN</b>	hemolytic disease of the fetus and newborn
<b>RHD<math>\psi</math></b>	RHD pseudogene
<b>SCD</b>	sickle cell disease
<b>SIMTI</b>	Italian Society of Transfusion Medicine
<b>ISBT</b>	International Society Blood Transfusion
<b>TTP</b>	thrombotic thrombocytopenic purpura
<b>VWF</b>	von Willebrand factor
<b>GFs</b>	growth factors
<b>CLL</b>	Chronic lymphocytic leukemia
<b>EFI</b>	European Federation for Immunogenetics
<b>JAICE</b>	Joint Accreditation Committee-ISCT & EBMT
<b>HSC</b>	Hematopoietic stem cells



## LIST OF FIGURES AND TABLES

---

*Table 1* History of transfusion medicine: historical periods

*Table 2.* Genotypes of the ABO Blood Groups

*Table 3.* Representative molecular changes in *RHD* alleles expressing distinct phenotypes of the D antigen

*Table 4.* Transfusion Medicine Improvements: key scientific discoveries and technologic advances in blood banking and transfusion medicine

*Table 5.* Typing of technical innovation and strategic managements.

*Table 6.* GFs Released by Activated Platelets

*Figure 1.* Image of veins from Harvey's exercitatio

*Figure 2.* First direct transfusion between human and animals and used instruments

*Figure 3.* Perpendicular section of the Impellor

*Figure 4.* Karl Landsteiner *Table*: the results of complete cross-testing

*Figure 5.* Robertson's bottle for citrate transfusion

*Figure 6.* Plasma Exchange treatment

*Figure 7* Plasma treatment double filtration

*Figure 8:* Duplication of the *RH* gene and loss of the *RHD* gene

*Figure 9.* *RHD* deletion

*Figure 10.* *RHD/RHCE* hairpin formation

*Figure 11.* Model of Rhesus proteins in the red blood cell membrane

*Figure 12.* The epidemiological study of allelic variants of the *RHD*, was approved by the President of SIMTI, Ph. Claudio Velati

# 1. INTRODUCTION

## 1.1 HISTORY OF TRANSFUSION MEDICINE

---

It is very difficult to date the beginning of transfusion medicine, since the blood has always been considered a key element in healing of many diseases.

The transfusion medicine history, in fact, begins with the transfusion and was marked by scientific knowledge of the last decades around the turn of the 19th into the 20th centuries: an increasing appreciation of a potential role in the management of surgical and obstetric bleeding, in severe non-surgical anemia, has transformed completely the history of transfusion medicine.

The blood transfusion has legendary and controversial origins.

One of the earliest manuscripts on the history of transfusion is dated 1875<sup>1</sup> (*Frati et al 2005*). The author distinguishes three periods: a period "*mythological*", empirical and legendary that ends with the discovery of the blood circulation (1628). An "*experimental*" period begins with 1628 to the end of the seventeenth century. A "*therapeutic*" period from the first 800 to the present day (*table 1*)

The *mythological period* has scarce and nuanced sources and is linked to the classical tradition.

In the classical tradition, in fact, blood was considered "lifeblood", seat of the soul and magical power. During the rites, the blood of the sacrificed victims was offered to gods as a gift. The warriors' tribes drank the enemies' blood to draw strength.

The first blood transfusions may already have been practiced by Egyptians, Greeks and Romans.

---

<sup>1</sup> DE CRISTOFORIS M., *La trasfusione del sangue*. Milano, Rechiedei, 1875.

As known, Egyptian physicians successfully performed brain surgery, so it is possible that the transfusion could be known and practiced. Also in ancient Egypt transfusion could be practiced as a geriatric care to prevent pharaoh's aging. The Egyptian papyri and the ancient temples inscriptions, in fact, handed down that Egyptian priests used the blood to cure the princes "oppressed by diseases of languor." For nearly 2,000 years, in Egypt the blood was regarded as the sovereign remedy for leprosy. The two greatest exponents of the School of Alexandria, Herophilus of Chalcedon (III aC). and Erasistrato of Giulide, use the verb "to transfuse" although it is doubtful that this refers to the practice exactly as we know it. (*Fрати et al 2005*).

Some Jewish writings tell the story of a Syrian prince cured of leprosy with oral fresh blood administration. This suggests that the ancients would use the blood for the diseases treatment or for the rejuvenation.

Hippocrates (460-355 aC), the Greek physician and modern medicine pioneer, prescribed blood administration in the treatment of the "falling sickness" although the mode of administration is not specified

In Roman times, the blood administration was oral exclusively. Empirical evidences showed that patients drinking blood were healed easily. So, the blood had healing power.

The ancient Rome's history haven't got transfusion's news. In a legend Tanaquilla, Tarquinius Priscus's wife, (577 aC), gave her blood to husband stabbed. The oral blood administration efficacy, was known to Celsus (60 aC: *De Medicina VIII*) and Pliny the Elder (23 d.C: *Naturalis histories*). They say that epileptics drank the warm blood of just killed gladiator. Tertullian (150 d.C) recommended the blood use in the treatment of debilitating conditions.

The first mentioned transfusion, regards Ovid's *Metamorphoses* (43 aC - 17 dC): Medea, learned the Egyptian priests' art used blood to rejuvenate old Exon. She took his blood by phlebotomy and led into his veins a "mood secret" able to rejuvenate.

This technique, used by the Romans to rejuvenate, was called "medeana care". For a long time remained the idea that the blood transfusion could rejuvenate. In fact, in the Renaissance Marsilio Ficino (1433-1499) recommended to drink the blood of young people to rejuvenate. There are a lot of information about the use of transfusion therapy in the Middle Ages. It is known that bloodletting therapy was frequent for release negative moods responsible of disease. Alternating purges, bloodletting was performed without any criteria and without any hygiene. The physician did a simple incision into a vein and let out half liter or liter of blood in the hope of freeing the patient from the disease. This practice was often repeated many times until then cause severe anemia and the sick was weak and vulnerable to other diseases. The practice of bloodletting became very popular so that the bloodletting practice was given to the barbers who hung out the door the wet blood bandages. From here the signs in red and white stripes of the barbers. The wide spread of bloodletting increased the number of deaths. Soon everyone realized that removing the blood did not help to heal any sick and that could be useful to give more blood to the sick (*Frati et al 2005*).

Thus was born the theory of transfusion.

The first documented blood transfusion seems to have been practiced to Pope Innocent VIII in 1492: a Jew physician used the blood of three children under 10 years to cure the pope. The children died and the pope didn't heal.

However, in this time, the transfusion history is between myth and reality and the cited sources narrate popular beliefs without scientific support. The mythological period, in fact, was concluded with first scientific studies of Realdo Colombo (1558). He studied the blood's path in the arteries and pulmonary veins and led to description of cardiovascular circuit by William Harvey in 1628. (*fig. 1*)

This finding suggested to transfuse blood directly into veins with rudimentary methods (urinary animals bladders, porcupine quills, heavy silver tubes). With these discoveries begins the *experimental period* and the first description of blood

transfusion process. With regard to techniques used for transfusion, in 1660 Francesco Folli (1624-1685) explained that was necessary to insert a silver cannula in a donor artery and an ivory cannula in a recipient vein. The two cannulas had to be connected by an elastic tube (*Frati et al 2005*).

These experiments spread rapidly in England, France, Germany and Italy, until in 1663 the Philosophical Society of London commissioned to physicians Daniel and Thomas Coxe to investigate about blood infusion and transfusion. They studied the effects of blood infusion in same and in different species animals. Also, they observed the effects from artery to vein and from vein to vein transfusion.

The observation that from these experiments weren't derived harmful consequences for animals, led to the first attempt to heterologous transfusion in humans. Jean-Baptiste Denis (1620-1704), physician of the court of Louis XIV, on March 3, 1667 transfused 16 years old young affect by unknown fever with lamb's blood (after twenty bloodletting in two months without success). The amount of blood transfused was nine ounces (270 gr.) (*fig.2*)

The patient's recovery and the experiment success was huge and spread in the Old Continent quickly. A large number of heterologous human transfusion was implemented to treat human diseases.

In London, Lower and King, using heterologous transfusion to treat mental illness, described methods for artery to vein transfusion and problems related to blood clots formation in the "*Tractatus de Corde idem et de motu et colore sanguinis*" (1669). In fact, the formation of blood clots in transfusion devices, was a real problem and begin the first rudimentary anticoagulants methods. At the time, in Germany, Mayor Jean Daniel (1667), describes "semi direct" transfusion and proposes a few grains of salt or deer horn or flower salt ammoniac to prevent blood clotting in pipes' silver.

In subsequent years, the blood heterologous transfusion spread quickly to cure very different diseases: insanity, chronic anemia, tuberculosis, stubborn fevers,

stomach cancer, typhoid without special precautions to prevent adverse reactions . The history don't report transfusion cases to treat acute hemorrhage anemia in this time.

The number of heterologous transfusions increased together with number of very dramatic failures. This procured many disappointments and the initial supporters enthusiasm was opposed to hostility of the most respected scientists.

In a hot climate, when the patient treated by Jean-Baptiste Denis died, the patient's family sued the physician at the Assize Court of the Chatelet. The death had occurred from arsenic poisoning, but the court of Paris (with a decree became law January 10, 1670) forbad in France the human blood transfusion. At that time, French culture ruled the roost in the scientific community: the English Parliament and the Pope adopted the same measure. Bartolomeo Santinello, Italian physician of the XVIII century, declared necessary to ban this operation for the "good of humanity"(Frati et al 2005).

The transfusion history and disputes between supporters and opponents came to the end and transfusions were not practiced throughout the XVIII century.

In the early XIX century occurred revival interest for transfusion medicine. At that time there was a general climate of interest in new medicine discoveries. An Italian physician, Michele Rosa (1731-1812), started interesting experiments on blood animals. He revived the correct setting of the animals experimental blood transfusion and studied psychomotor manifestations on animals brought to the death by total bloodletting.

So scientists studied causes and pathophysiology of blood transfusion consequences and thus began the *therapeutic period* (evolving today).

In 1818, the British obstetrician James Blundell (1790-1878), demonstrated the incompatibility of heterologous transfusions and the need to use human blood for humans. For the first time, he performed a successful transfusion of human blood to a patient with postpartum hemorrhage. He used husband' blood (as a donor) to

perform arm to arm transfusion. He also devised the use of autologous blood for transfusions, recovering that lost in women with postpartum hemorrhage. Blundell introduced two instruments for the purpose of transfusion: the impellor and the gravitator. The impellor was a complex invention consisting of a cup, tube and syringe. When using the gravitator, blood was injected into the patient via a tube suspended from a vessel held high above the patient. Information on both apparatuses was published in *The Lancet* in 1829. (*Fig 3*)

The patients' observation after transfusion has allowed to describe post transfusion clinical features: shivering with fever, anxiety, thirsty air, tachycardia, hematuria, cyanosis, dyspnea, cough with frothy bleeding sputum, distended jugular veins. These complications were due to incomprehensible phenomena in those days: incompatibility, overload, contamination for lack sterility, imperfect knowledge of blood composition. The scientists understood that these effects were due to the different species of blood, therefore was prohibited heterologous transfusion.

In 1882, Julius Friedrich Cohnheim (1839-1884) introduced the "blood compatibility" that led to practice exclusively inter-human transfusions: post-transfusion accidents were reduced greatly, but the failures were not entirely disappeared. So, the research had found a new area of interest: to know and characterize the blood to understand the differences between individuals of the same species (*Boulton 2013. Part 1*).

Among all the researchers, the most famous name is Karl Landsteiner (1868-1943), considered the father of immunogenetics and the initiator of the transfusion science. He discovered that red blood cells of individuals can differ antigenically and found the properties of red blood cells agglutination. Using serological methods, he had been impressed that "the proteins in various animals and plants are different and are specific for each species." He wondered "whether ... individuals within a species show similar ... differences. As no observations whatever were available pointing to such behavior, I chose the simplest among the possible plans of investigation ...

allowing blood serum and red blood corpuscles of different human individuals to interact” (*Lansdteiner 1931*). In fact, by simply mixing serum and erythrocytes from different person and comparing their pattern of reactions, he could classify blood into three groups. The occurrence of agglutination indicated the existence of natural or preexisting antibodies against foreign blood groups. In the 1901 paper he tabulated the results of complete cross-testing of the sera and cells of six people working in his lab, including himself (*fig 4*). He noted first that the serum of none of the six individuals reacted with the person's own cells—a clear observation of self-tolerance (*Owen 2000*)

Those with group A blood cells had antibodies to group B cells; those with group B blood cells reacted with group A cells; and the serum of group C people agglutinated erythrocytes of both group A and B people. Today group C is known as group O. The fourth group, AB, was discovered a year later, and these rare individuals lack both isotypic agglutinating antibodies. Landsteiner's work led to a reduction in the risk of blood transfusions, which had previously and unpredictably resulted in toxic shock: it provided a scientific explanation and a method for determining transfusion compatibility. In 1901, Landsteiner classified blood groups (ABO) and found that their determination depended on hereditary factors, transmitted from generation according to Mendel's laws. He received the Nobel Prize for Medicine in 1930 for this discovery (*Boulton 2013. Part 1*).

The diversity of blood groups among individuals, gave a new understanding of transfusion: it's necessary to seek donor and recipient RBC characteristics and to respect the patterns of compatibility. This has increased the safety of blood transfusions and reduced postoperative deaths. The concept of donor and recipient compatibility was enhanced in 1907 when Hektoen introduced compatibility testing combining in vitro blood donor and blood recipient to exclude incompatibility (cross match).



The first four blood groups to be discovered not distinguish individuals, but with the addition of the minor erythrocyte antigens, individualistic sets emerged. In the 1908, Ehrlich and Morgenroth (*Kaufmann S 2008*), the fathers of immunology, had early shown that when blood of one goat was injected into another goat immune antibodies that reacted with the donor', not the recipient's cells appeared and that these antisera recognized a complexity of individual differences among goats. By 1910, Todd and White had published similar studies of cattle and chickens, work indicating that any individual within a species had an almost unique individuality. Landsteiner wondered why, given a match for ABO, human transfusions did not readily reveal such individuality with Levine (1927); tried injecting rabbits with human blood and using the immune sera to detect differences among people. This led to the next marker for human genetics, the M-N alternative, later to prove so complicated. The same experiments revealed the P groups.

The immuno-haematological knowledge were compiled in 1940 when Landsteiner and Wiener discovered "Rh" factor (or Rhesus factor), an blood cells antigen involved to pre transfusion compatibility. They inject cells from Rhesus monkeys into guinea pigs and rabbits and see if the resulting antisera distinguished human characteristics (*Owen 2000*). This led to the recognition of the Rh system, named for the Rhesus donors; they discovery Rh factor in human blood and classified human population in Rh positive and Rh negative depending on red blood cells agglutination with anti-Rhesus serum.

Blood incompatibility in the special jet common circumstance of the Rh antigen can be fatal and id the theme of a report by Philip Levine (1941) and his colleagues. It concerns how one self accepts or rejects another self within its territory, specifically how an Rh negative mother becomes sensitized to and subsequently kills an Rh positive fetus developing within her. The disease is erythroblastosis fetalis and the milestone established its immunological origin. Levine's team knew that, like ABO

blood groups, the Rh antigen was inherited by Mendelian process, but the underlying genetics mechanisms were unknown.

However the main hazard, perceived from early attempts, was ordinary blood clotting, not blood group incompatibility. After the anatomical demonstration of the blood circulation and the blood groups identification, it was necessary to have not coagulated blood for transfusions.

When blood was taken from a prospective donor, it clotted during the transfusion process, to conspicuously ill effect on the recipient. Shortly after 1900 surgeons developed extraordinary methods of joining an artery of the donor with a vein of the recipient so that the blood was not exposed to clotting during transfer (direct transfusion).

At the beginning of the last century (1902), the pharmacologist Luigi Sabbatini (1863-1928) discovered anticoagulant properties of sodium citrate (*Mann 2007*). It has revolutionized the transfusion technique because transforming direct in indirect transfusion. Also, he found that citrate preserve long and unaltered blood characteristic allowing blood storage at 4-6° C in containers for a few days after collection.

This discovered was very important because the use of an anticoagulant (citrate) solved the clotting problems and allowed the extensive use of transfusions in the First World War. The first transfusion of citrated blood given to a human seems to have been performed by Hustin (1914) (*Mollison 2000*).

In 1918, Oswald Robertson added dextrose to sodium citrate obtaining the anticoagulant solution ACD (citric acid-citrate-dextrose) that allowed blood storing up to 21 days and published a remarkable paper, describing transfusions of stored red cells given near the front line in France in the First World War (*Robertson 1918*). Only 4 years had elapsed since the first few transfusions of citrated blood had been given to human subjects; the method of storage which was used had not previously been applied to transfusion in humans. Robertson used a bottle with a capacity of 900±1000

cc; 160 cc of 3,8% citrate was used and marks made on the bottle at 660 corresponding to 500 cc blood, etc. (*Fig 5*).

For the first time, a bank of units of stored blood was created and shown to be of great practical value. The first Transfusion Centre was organized in Paris at the Hospital Saint Antoine in 1923; later many other centers sprang up across Europe and America. In 1930 was formed the first "Blood Bank" at the London Hospital.

The transfusion improvements and increased transfusion requirements during the Second World War, gave a strong boost to transfusion research.

In 1947 was formed the American Association of Blood Banks (AABB) to promote common results between the transfusion centers. The US government, to ensure improving assistance to military troops, financed many research projects. Thus began a spontaneous donation publicity based on solidarity: in the cities war involved were hung posters that reminded: "Donate blood, now!", "Your blood can save him" and "He gave his blood. How about you? ". Thus were born the association aimed at blood donation. In the United States, during the Second World War, were given about 13 million units of blood. It is estimated that in London they have been collected and distributed more than 260,000 liters. After Second World War, important medicine improvements made possible surgeries unimaginable once.

In 1952, Carl Walter introduced the plastic blood bags for the blood collection, indispensable for simple and safe collection system.

Furthermore it was introduced the refrigerated centrifuge which allowed to separate multiple blood components from a single blood unit: in this way it is possible to separate red blood cells, plasma and platelets from whole blood. This represented a real revolution for transfusion medicine because with the blood components it's possible to transfuse the patient only what is needed to cure. In fact, according to clinical indications, it is possible to administer individual blood fractions, plasma and blood components (red blood cell, white cell, platelet, human plasma and its fractions).

This opens the era of actually transfusion medicine, in which the transfusion physician, specifically trained, participates in the sick care actively.

## **HISTORY OF TRANSFUSION MEDICINE: HISTORICAL PERIODS**

### **MYTHOLOGICAL PERIOD**

- Blood is considered "lifeblood", seat of the soul and magical power in the Egyptian papyri and Jewish writings
- The first blood transfusions may already have been practiced by Egyptians, Greeks and Romans.
- Hippocrates (460-355 aC), prescribed blood administration in the treatment of the "falling sickness"
- In roman times exclusively blood oral administration
- Ovid's *Metamorphoses* (43 aC - 17 dC): first mentioned transfusion for disease's treatment or for the rejuvenation ("medeana care")
- In the Middle Ages was frequent bloodletting therapy for release negative moods responsible of disease.
- The first documented blood transfusion has been practiced to Pope Innocent VIII (1492)
- The transfusion history is between myth and reality

### **EXPERIMENTAL PERIOD**

- 1558: Realdo Colombo described the blood's path in the arteries and pulmonary veins
- 1628: William Harvey described cardiovascular circuit
- 1660: Francesco Folli inserted a silver cannula in a donor artery and a ivory cannula in a recipient vein and connected with an elastic tube.
- 1667: Jean-Baptiste Denis performed first direct heterologous human transfusion
- 1670 the Assize Court of the Chatelet (Paris) forbad in France the human blood transfusion .
- In Europe transfusions were not practiced throughout the XVIII century

### **THERAPEUTIC PERIOD**

- 1818: James Blundell demonstrated the incompatibility of heterologous transfusions and the need to use human blood for humans
- 1882, Julius Friedrich Cohnheim introduced the "blood compatibility"
- 1901: Landsteiner classified blood groups (ABO)
- 1902: Sabbatini discovered blood anticoagulant (citrate)
- 1907: Hektoen introduced compatibility testing
- 1914: First transfusion of citrated blood given to a human performed by Hustin
- 1918: Oswald Robertson added dextrose to sodium citrate obtaining the anticoagulant solution (ACD). Begin the blood banking
- 1923: First Transfusion Centre in Paris at the Hospital Saint Antoine
- 1927: Landsteiner and Levine discovered erythrocyte's minor antigens (MN and P)
- 1930: First "Blood Bank" at the London Hospital.
- 1940: Landsteiner and Wiener discovered "Rh" factor
- 1941: Philip Levine discovered erythroblastosis fetalis and established its immunological origin
- 1947: Beginning of American Association of Blood Banks (AABB)
- 1952: Carl Walter introduced plastic blood bag

Table 1: M. De Cristofori (*La trasfusione del sangue*, 1875) distinguishes three periods:

a period "mythological", empirical and legendary that ends with the discovery of the blood circulation (1628). An "experimental" period begins with 1628 to the end of the seventeenth century. A "therapeutic" period from the first 800 to the present day

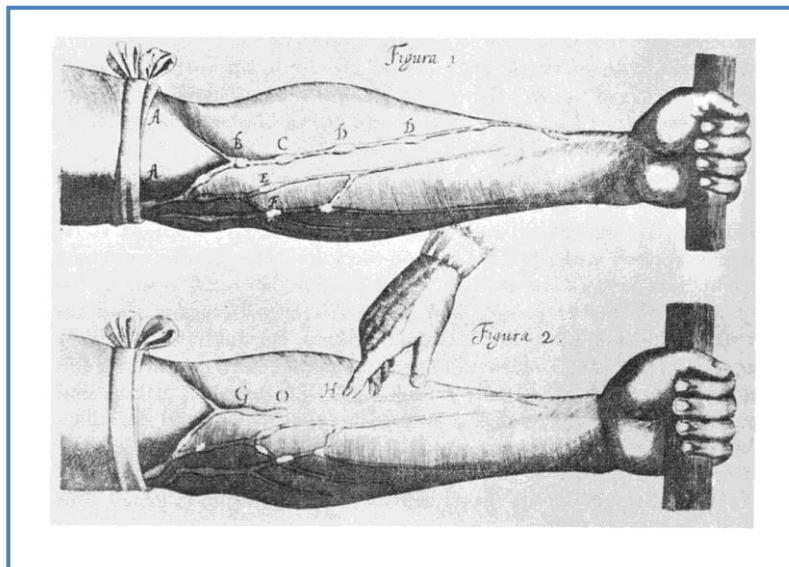
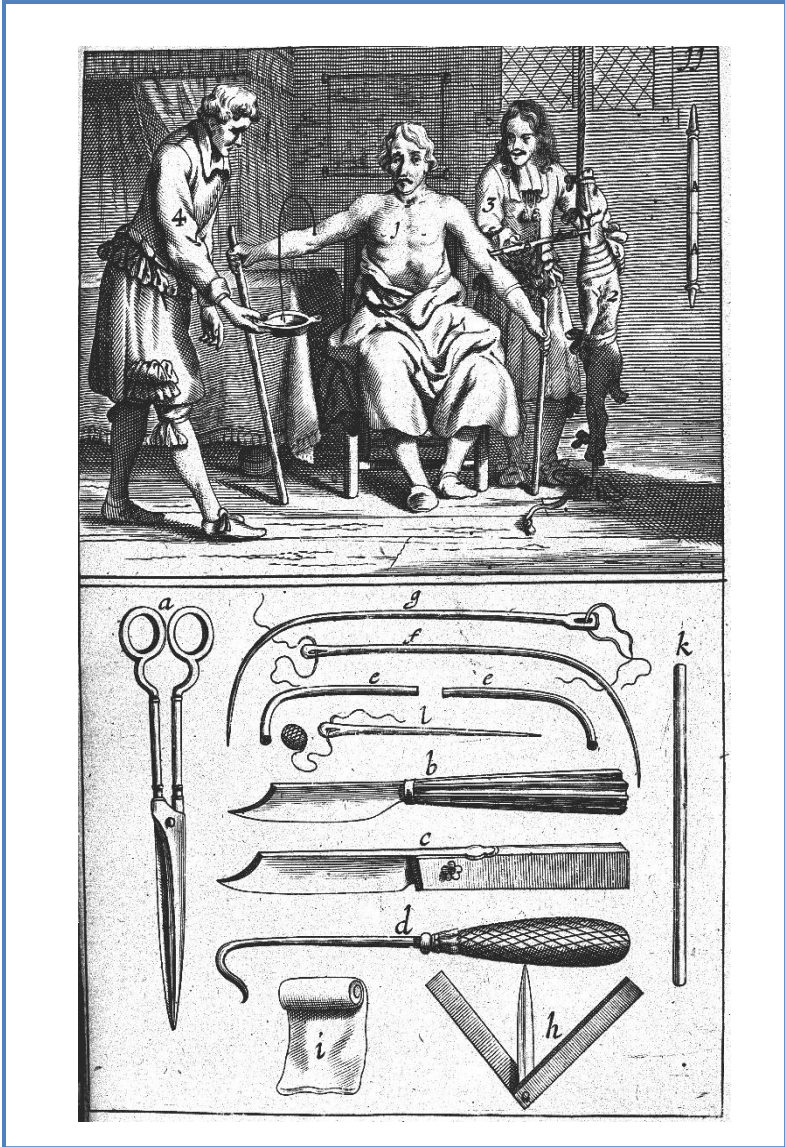

Fig. 1. William Harvey (1578-1657) Image of veins from Harvey's exercitatio



*Fig 2.* Jean-Baptiste Denis (1620-1704): First direct transfusion between human and animals and used instruments



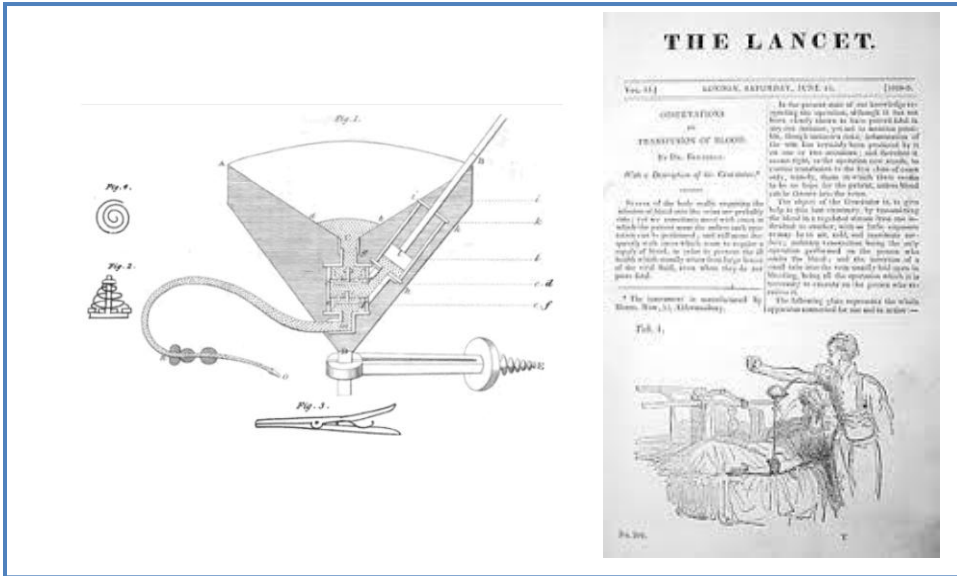

Fig 3 .Perpendicular section of the Impellor, a complex invention consisting of a cup, tube and syringe published in The Lancet in 1829

**TABLE I**  
Concerning the blood of six apparently healthy men

Sera	Blood corpuscles of					
	Dr. St.	Dr. Plecn.	Dr. Sturl.	Dr. Erdth.	Zar.	Landst.
Dr. St.	-	+	+	+	+	-
Dr. Plecn.	-	-	+	+	-	-
Dr. Sturl.	-	+	-	-	+	-
Dr. Erdth.	-	+	-	-	+	-
Zar.	-	-	+	+	-	-
Landst.	-	+	+	+	+	-

Fig 4. Karl Landsteiner, 1931. Photo of the National Academy of Sciences. Table: the results of complete cross-testing of the sera and cells of six people working in his lab including himself



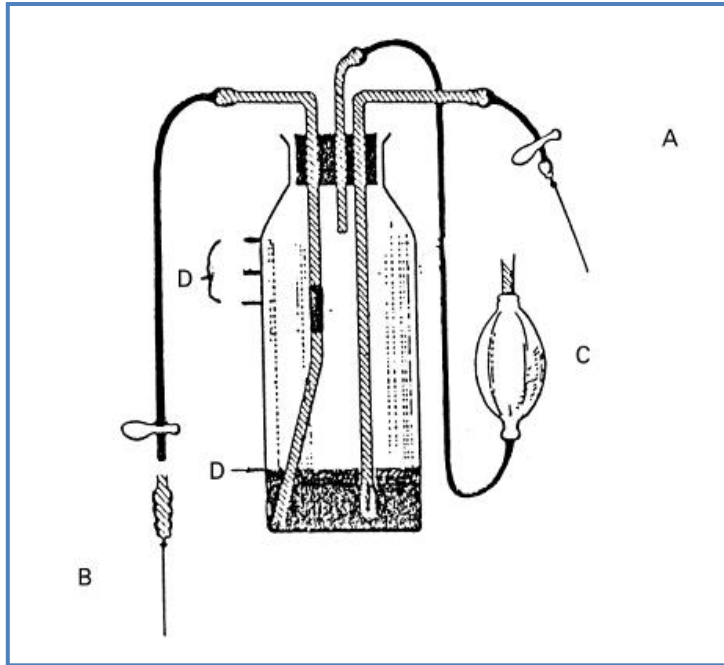

*Fig 5. Robertson's bottle for citrate transfusion. (A) Line from donor. (B) Line to recipient (C) Rubber bulb with valve (Higginson's syringe), supplying either negative or positive pressure. (D) Marks are made on the bottle (which has a capacity of  $900\pm 1000$  cc) at 160, 660, 760 and 860 cc; citrate is added to the 160 mark and the donor is bled to one of the upper marks, corresponding to  $500\pm 700$  cc blood (Mollison P.L. *British Journal of Haematology*, 2000; 108: 15)*

## **1.2 CONTEMPORARY TRANSFUSION MEDICINE: the last 20 years of discovery**

---

The last few decades have been very important for transfusion medicine history. In particular, some innovative therapy techniques and cellular manipulation, have radically changed the transfusion medicine services identity and have had a huge impact on patient care.

In fact, the main scientific findings include: apheresis technology, marrow and hematopoietic stem cells, RBC antigens and antibodies, the role of the WBC, PLT and neutrophil antigens and antibodies, volunteer blood donors, blood safety, hematopoietic growth factors, plasma derivatives, blood utilization and management.

Our attention will be focused in particular on four key aspects of modern transfusion medicine: therapeutic apheresis, regenerative medicine, stem cells and molecular biology.

The aphaeresis is based on the principle of the whole blood separation by extracorporeal circuits. It 'a very sophisticated technique that allows to isolate the blood elements (liquid or corpuscular) and to manage them independently. The donor of multicomponent and the blood recipient are not exposed to significant risks. The physician responsible (before the procedure) explains possible risks and the patient or donor accepted and expressing their informed consent.

The therapeutic application of these techniques, has radically changed the natural history of many diseases.

The ability to use non transfusion blood components , has opened new frontiers in transfusion medicine. Using bioregenerative capacity of platelets growth factors, it's possible to intervene in many clinical areas (surgical and aesthetic) to promote the regeneration of damaged tissues or to tissue repair.

In relation to these arguments, there is a growing scientific interest. A very strong push was given by the integration of apheresis and tissue regeneration. This has led over the past 20 years using aphaeresis to produce stem cells using peripheral blood.

The bone marrow is rich in stem cells. The recruitment of bone marrow donors community volunteers represented the beginning of clinical use of stem cells. In recent years, was possible to increase the number of peripheral blood stem cells and allow the removal of the stem cells by aphaeresis. This improvements opened the way to many novel cellular therapy. Blood banks took the lead in marrow donor recruitment.

Last important aspect of contemporary transfusion medicine is the use of molecular biology. The application of molecular techniques for the genetic study of erythrocyte antigens, for example, has strong implemented immunohaematological knowledge and has solved many transfusion problems. In particular, today, they are widely used for extended red cell antigens typing (minor red cell antigens and allelic Rh variants) for the banking of rare red blood cells. Obviously in the transfusion field the technique is applied to the stem cells molecular HLA typing and is used as improvement for the diagnosis of many diseases treated by transfusion medicine (genetic study of hemoglobinopathy or PPT).

### **1.2.1. Therapeutic Apheresis**

The first episode of use of aphaeresis in humans, dating back to 1930, when Soloman and Fahey used plasmapheresis in treatment of macroglobulinemia of Waldestrom, an hyperviscosity syndrome. (*Salomon 1962*) The therapy consisted of removal patient's plasma and reinfusion of isotonic saline. In this way hyperviscosity due to immunoglobulin excess had correct and had improved the clinical symptoms (*Raynolds 1981*). The plasma exchange, was symptomatic therapy because corrected the symptom (hyperviscosity) and didn't act on the causes (excess immunoglobulins production).

The first device for therapeutic aphaeresis dates 1962, when IBM and the National Cancer Institute in Bethesda (USA) designed a prototype centrifuge to remove the white blood cells. Since then, the therapeutic removal of cells or pathological

molecules was carried out by different methods, developed according to different pathophysiological mechanism's disease. The knowledge of the pathophysiological's diseases, has encouraged the development of different apheretic techniques with appropriateness prescriptive.

The principle of therapeutic aphaeresis, is the selective removal of pathogens or excessive blood components (cells or molecules). This removal is performed using extracorporeal circulation technique and anticoagulants (citrate or heparin) to prevent blood clotting. In the last decade, technological change and computerization improved the existing techniques and promoted more selective removal of pathological particles in the plasma (LDL cholesterol, fibrinogen, immunoglobulin, circulating immune complexes, toxins) and collection of cellular elements (platelets, leukocyte, lymphocyte stem cells).

The therapeutic aphaeresis techniques can be grouped into three major groups: exchange cell therapy (plasma exchange/ erythroexchange), plasma treatment and therapeutic erythrocytapheresis.

a. **Plasma exchange (PEX):** PEX consists in removing the plasma patient and the replacement with substituent solution (fresh frozen plasma, electrolytic solutions, albumin). The pathogenic molecules are removed with the plasma, changing the natural history of the disease. According to international guidelines ASFA (American Society for Apheresis), PEX can be considerate the I or II line treatment (category I and II) and usually is compensated with drug therapy to act on the causes of disease. The PEX treatment consist in multiple cycles that includes daily treatments on consecutive days. In each daily treatment are defined exchanged volume, treatment frequency and type of substituent solution according to ASFA guidelines. Each PEX procedure comprises several cycles consisting of two step: a step for blood collection and a step for reinfusion. After collection, the blood is centrifuged. The blood centrifugation allows cellular elements and plasma separation according to different

specific weight. The patient's plasma collected is discarded and the patient receives his blood cells and substituent liquid (plasma or albumin) in the reinfusion step (*fig.6*). The duration of treatment (usually 2 to 4 hours) depends on the volume to be exchanged and on the rate of exchange. The side effects PEX related may be due to extracorporeal treatment and to anticoagulant use. Anticoagulant can move into the circulation giving transient disturbances due to hypocalcaemia. Moreover the use of fresh frozen plasma as a fluid-replacement, exposes the patient to anaphylactic or allergic reaction.

b. **Erythro Exchange:** The exchange of erythrocyte is used for treatment of acute stroke and chest syndrome, a dramatic clinical conditions due to erythrocyte deformation and anemia of sickle cell anemia. The sickle red blood cells are unable to cross in the microcirculation and it causes the vascular occlusion and stasis. The blood transfusion, improves the anemia, but increases blood viscosity and hematocrit and increases stasis and vascular occlusion. The purpose of erythro exchange is to replace sickled with normal cells. In this way it's possible improve clinical symptoms without increasing blood viscosity, reduce the hemolysis and iron accumulation. The exchange is performed by erythrocyte cell separator: after collection, whole blood is centrifuged and separated by gradient centrifugation. The patient's erythrocytes collected are discarded and the patient receives his plasma and compatible normal erythrocytes Any procedure exchange one red cell volume corresponding to. 15-20 ml / kg. Thus, average weight patient (i.e: 60 kg) exchanged 1200 ml of concentrated red blood cells corresponding to 4 RBCs units. RBCs transfused must be of recent production (no more than 2 weeks) and produced by aphaeresis, preferably. Each RBCs unit is matched for ABO, Rh and Kell antigenic systems (perfect match is ABO-D, Rh, Kell, Duffy, MNSs) and performed compatibility tests. This type of therapy and the number of sessions to be repeated, exposes the patient to the risk of alloimmunization, the formation of antibodies directed against non-self erythrocyte minor antigens untyped

and not observed for RBCs selection. So, the alloantibodies are always sought after and their presence or their immune memory is always considered to assign units of RBCs.

c. **Plasma treatment:** it's the plasma filtration with semi-selective (cascade filtration) or selective (adsorption) techniques. The patient's plasma, separated and treated, is returned to the patient without pathogenic molecules. This reduces the risk of anaphylactic reactions to not self protein molecules, characteristic of plasma transfusion.

The filtration techniques are: cascade filtration and adsorption.

· *Cascade Filtration or double filtration:* It's a technique of physic plasma separation obtained by centrifugation extracorporeal into cell-separators. Two series filters are used. The first separator filter is formed by high cut-off micro pores (270 to 400 microns) for blood cells separation (erythrocytes, leukocytes, platelets). The second filter or fractionation filter is formed by low cut-off micro pores (70 microns) for molecular weight separation. The excessive high weight molecules (immune complexes, IgM, fibrinogen, LDL-C) may be dangerous in many disease. So the cascade filtration consent to eliminate the high weight molecules and to give back to the patient the plasma containing lower weight molecules (electrolytes, substances with a low pm, albumin) and the cells separated and collected by first filter (RBC, WBC, PLT) (*Fig 7*). The filtration procedure consent to treat 2-3 liters of plasma (40-50 ml/kg) (*Kardaş et al 2012*)

· *Adsorption:* Aphaeretic technique to remove plasma pathogenic molecules by columns adsorbed with specific ligands. The adsorption can be chemical, immunological or physic. After collection, patient's whole blood is separated by centrifugation or high molecular weight filtration; so are obtained plasma and cellular blood components (RBC, WBC, PLT). The plasma is adsorbed on specific columns containing selective ligands specific to treat pathology. When the plasma is deprived

of pathogenic molecules, it is collected and rein fused to the patient with cellular component. This method is highly selective and acts on the pathogenic mechanisms of disease. The true limits relate the columns costs: in relation to substance plasma concentration and to ligand used volume, columns saturate quickly. Therefore, usually, it is preferable to treat disease with other treatment options, with less expensive techniques, limiting the use of adsorption in a few clinical cases. In particular, this technique is used for the selective removal of LDL low density lipoprotein (LDL apheresis). The LDL apheresis columns contain anti lipoproteins apo B100 antibodies obtained to sheep serum and adhering to a solid sepharose matrix. In general, the ligands are chemical (dextran sulfate, acrylic acid, activated carbon, resins polyanionic, heparin), physic-chemical (phenylalanine, tryptophan and styrene-divinylbenzene) or biological (protein A for the adsorption of IgG). The selection of column type depends on treated pathology. The treatment of chronic liver failure, primary biliary cirrhosis, decompensated cirrhosis and hyperbilirubinemia pre and post liver transplant consist in bilirubin (conjugated and unconjugated) and bile acids adsorption. Some autoimmune diseases (multiple sclerosis systemic sclerosis, SLE, RA, Guillain-Barre syndrome Fischer) can be treated with physic-chemical columns containing phenylalanine, able to absorb antibodies and immune complexes or in some cases (Guillain-Barre and Fischer Syndrome, chronic demyelinating polyneuropathy) with columns containing tryptophan able to remove IgG and ACh-R-Ab

d. **Therapeutic cytapheresis:** This technique is mainly used for the selective cell depletion of leukocytes, erythrocytes or platelets. It removes excess pathogenic cells responsible for serious clinical symptom. Once, this effect was obtained only with the therapeutic phlebotomy, that removing the whole blood, depriving the patient also elements useful for his health. In the 60's were introduced cell separators based on gradient centrifugation of blood cells. So, it's possible to separate whole blood into its cellular components and plasma using the different sedimentation coefficients when

the cells are subjected to an appropriate centrifugal force (G-force). In this way, can be deleted only the pathological cells in excess and the rest of the blood can be re infused to patient. The main application areas are hematological diseases: the platelet apheresis therapy is performed in cases of severe thrombocytosis to reduce the risk of thrombosis. (*Russi et al 2008*).The therapeutic leukapheresis is used to remove buffy coat in high risk of bleeding thrombosis and pulmonary leukostasis hematological malignancies,. The erythroapheresis therapy is used to restore the correct values of haematocrit (necessary to correct hyperviscosity) in patients with primary or secondary erythrocytosis symptomatic. However, if therapy depletion is not accompanied by appropriate drug therapy, has only temporary effects. A particular type of therapeutic cytapheresis is photoapheresis therapeutic. In the last 20 years, this technique has revolutionized the follow-up and outcome of patients with GVHD. It is a technique of therapeutic leucapheresis in which the patient's white blood cells (collected by centrifugation), are treated with 8-methoxypsoralen, irradiated with UVA and then reinfused to the patient. This cell manipulation triggers apoptosis of leukocytes that activates dendritic cells, modulating the effects of GVHD and monitoring the effects of rejection of solid organ transplantation (*Bruserud et al 2014*)



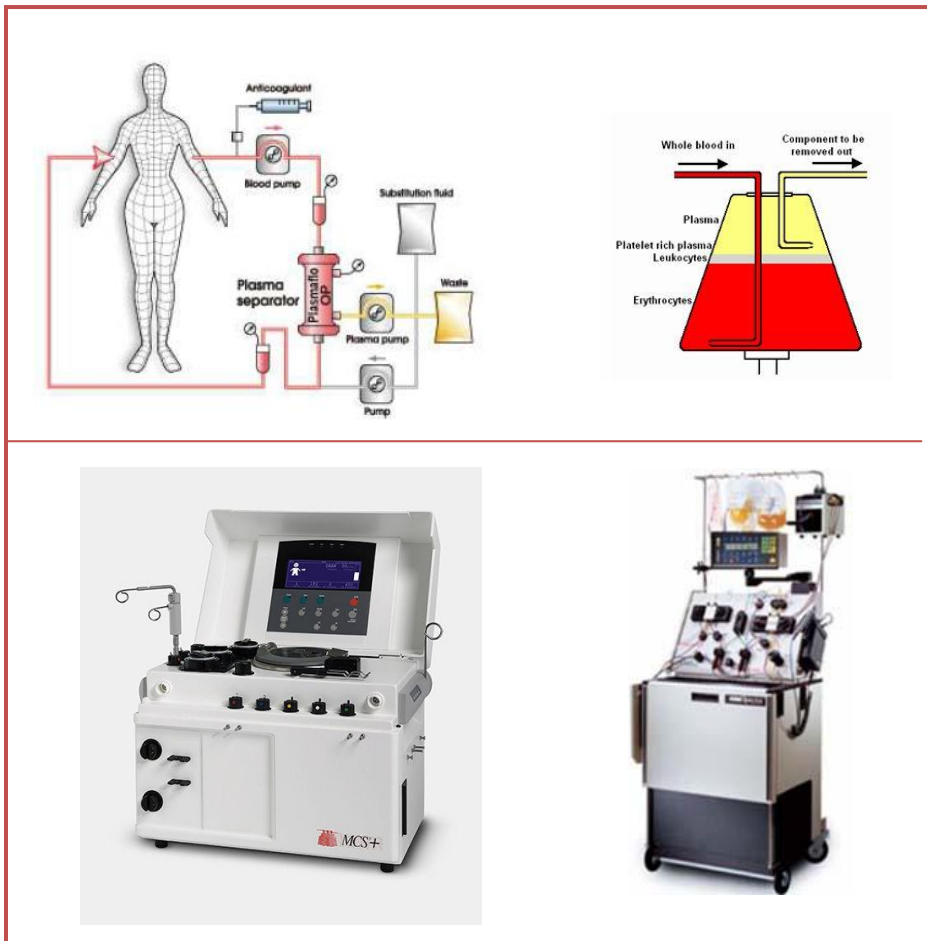

Fig 6. Plasma Exchange treatment diagram and particular of bowl blood centrifugation (up). Modern cell separators used for aphaeresis procedures (down)

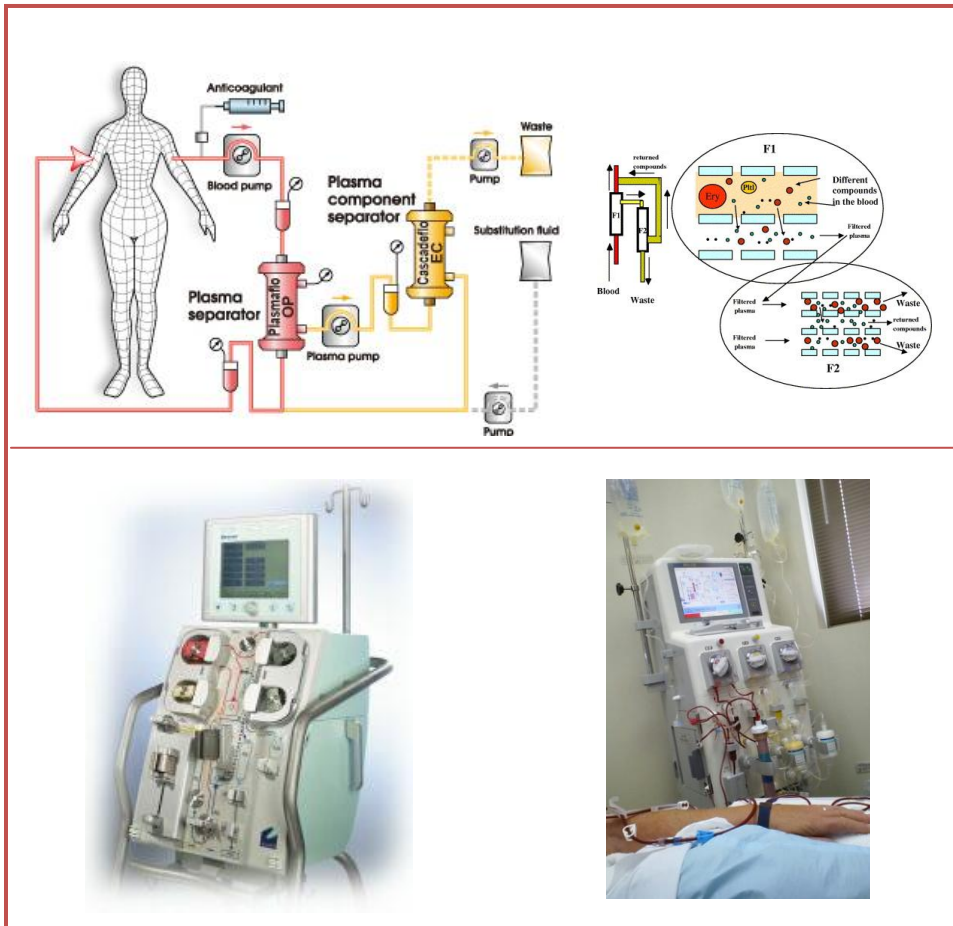

Fig 7 Plasma treatment double filtration diagram and particular of filtration (up).  
 Modern cell separators used for plasma filtration (down)

### 1.2.2. Regenerative medicine

Regenerative medicine can be considered the final frontier for the treatment of many diseases and represents a new philosophy to approach tissue/ organ degeneration by biological regeneration. In particular it is possible to use blood products for not transfusion use and their ability to initiate the regenerative stimulus and tissues repair.

In the 70s, for the first time, fibrin glue was produced and used to accelerate tissue repair processes in surgery. In the 80s, David Knighton developed in vitro a platelets stimulation technique by thrombin solutions for collection of a rich growth factors supernatant topically applied in the gel form.

The use of not transfusion blood components begins in 1998 with the first publication of Marx et al. on the use of platelet concentrates in dental surgery (*Marx et al 1998*). With the first clinical successes, interest has extended to other medicine and surgery fields and several methods of production and other clinical indications have been proposed.

This gel is able to stimulate the skin ulcers repair and to accelerate tissue regeneration in a variety of clinical and aesthetic settings: platelet concentrate is a source of growth factors and is used both in liquid form that enabled, as a promoter of damaged tissues regeneration (*Coppola 2004; Knighon 1990*).

The platelets growth factors (GFs) are capable of several function: to induce mesenchymal cells replication and chemotactic action to the inflammatory cells (polymorphonuclear leukocytes, monocytes, and macrophages), to proteases release from other cells activating tissue remodeling. (*Rughetti 2006*) Therefore, platelet are not only the protagonists of the haemostatic process, but also has a key role in inflammatory process (because they have high concentrations of pro-inflammatory chemokines or immuno- modulatory), in antimicrobial defense (since the  $\alpha$ -granules are rich in "protein microbicide platelet "-CXCL4 , thymosin -  $\beta$ 4 , derivatives of

CXCL7- PBP ,CTAP - III ,NAP- 2 and CCL5 -6 and complement proteins), in cell replication (mitogenesis), in angiogenesis and in modulate tissue regeneration. (*Gallagher 2007; Lucarelli 2003*)

Nowadays, there are many literature's studies on the use of platelet gel and growth factors (GFs) contained in the platelets's  $\alpha$ -granules (PDGF, TGF- $\beta$ , EGF, FGF, VEGF, IGF-1).

Platelets activated produce angiogenesis factors (VEGF, PDGF, FGF, EGF, HGF, IGF) to promote vascular wall permeability, endothelial and fibroblasts cells recruitment, growth and proliferation. (*Tang et al 2002; Kisucka et al 2006; Nurden et al 2008*)

As opposed, platelets inhibit angiogenesis by endothelial cells apoptosis (TSP-1 is a potent endothelial cell proliferation inhibitor; CXCL4 prevents binding of VEGF to its cell receptor and interferes with the mitogenic effect of FGF and other proteins such as angiostatin, endostatin and TIMP -1 and -4). (*Jimenez et al 2000; Bikfalvi 2004*)

Therefore, the use of platelet gel is effective in the treatment of various diseases (skin ulcers, reduction of inflammation, increased angiogenesis, stimulation of granulation tissue). Stimulation on bone regeneration and soft tissue, has led to its use in maxillofacial surgery, in odontostomatology (implants, sinus lift, cleft palate), in orthopedics and traumatology (soft tissue injuries, nonunion, loss of substance bone following trauma or removal of cysts), in ophthalmology (corneal epithelial injury), in cardiac surgery (sternal wound dehiscence) and in other disciplines in which is appreciated effectiveness, ease of use and lack of reactions or events adverse. Numerous evidences have tested gel platelet efficacy on skin ulcers repair (traumatic, vascular, neuropathic, diabetic, osteomyelitic, decubitus), on orthopedics disease (osteosynthesis, pseudoarthrosis, osteotomies, joint replacement, infiltration intra-articular), on maxillofacial surgery, on stomatology (ablative interventions of the maxillofacial region, mandibular reconstruction, maxillary sinus), on ophthalmology

(topical corneal lesions), on plastic surgery and cosmetic medicine. (*Champion et al 1998; Misso et al 2006; Bryne et al 1991; Holloway et al 1993*) According to the Standards of Transfusion Medicine, allogeneic or autologous not transfusion blood components, can be used topical, on skin or mucosal surfaces; for intra-tissue infiltration; local application in surgical sites, alone or with the addition of non-cellular biological material (e.g. bone tissue bank) or with medical devices. These products must be produced by a Transfusion Medicine Laboratory and must meet the criteria for the request, assignment, delivery and haemovigilance and guarantee the identification and traceability of the donor and recipient.

In particular, can be produced:

a. **Platelet concentrate** (allogeneic or autologous): prepared from whole blood or multicomponent apheresis or blood sampling in dedicated device. Can be used fresh or frozen and contained defined and variable volume according to the type of use. In conjunction with the production of platelet concentrate, can be produced thrombin used as platelets activator.

b. **Platelet gel:** (allogeneic or autologous).it is obtained from platelet concentrate activated at the site of application or in the production phase and delivered ready for use, fresh or frozen.

c. **Autologous serum eye drops.** It is produced from a blood sample in which the coagulation is activated and then separate the serum component.

d. **Platelet concentrate eye drops.** It is produced from autologous platelet concentrate

e. **Fibrin glue.** It is a topical biological adhesive which mimics the final stages of coagulation: from the fibrinogen chain thrombin splits into peptide A and B to form a monomer, which polymerizes to form fibrin clot at the site of application. Fibrin glue is a adjunct treatment in numerous surgical fields and is beneficial involve a high risk of postoperative bleeding or the leakage of air, blood and other fluids. The structural composition of fibrin and the binding of fibrin to cells and proteins

determines the wound healing process. This represents an ideal delivery vehicle for additional cells for the treatment of chronic wounds.

### **1.2.3. Stem cells**

At the beginning of the 20th century, Alexander Maximow says that in the peripheral blood there was a small number of circulating cells that has been able to be pluripotent and he called these cells "gemeinsame Stamzellen".

After several decades of attempts, the existence of these stem cells, was confirmed, Hematopoietic Stem Cells (HSC), cells with the capacity to self renew and the potential to generate mature specialized cell types; they are able to differentiate into cell types within the tissue in which they reside ("stem cell plasticity"). When a stem cell divides, the daughter cells can either differentiate in a specialized cell or self renew to remain a stem cell, so ensuring that the pool of stem cells is constantly replenished; this is a necessary physiological mechanism for the maintenance of the cellular composition of tissues and organs in the body. (*Jansen et al 2005*)

The general characteristics of stem cells can be classified as totipotent, pluripotent and multipotent.

*Totipotency* is the ability to form all cell types; totipotent cells can basically form the whole organism because they have unlimited capability.

*Pluripotency* is the ability to form several cell types but not the whole organism. There are four classes of pluripotent stem cells: embryonic stem cells, embryonic germ cells, embryonic carcinoma cells and the adult progenitor cells from bone marrow.

*Multipotency* is the ability to generate a limited range of differentiated cell lineages appropriate to their location, e.g. blood stem cells which give rise to red blood cells, white blood cells and platelets. (*Durand et al 2005*)

HSC transplantations started in the late 1940's with experiments in mice. Starting in the late 1950's several groups tried to apply these concepts to the treatment of patients with leukemia, and in the late 1970's these concepts gained acceptance:

allogenic or autologous bone marrow as source of stem cells, was used for all clinical transplantations ; while, at that time ,peripheral blood as a source of stem cells was still considered inadequate to permanently reconstitute hematopoiesis. (*Jansen et al 2005*)

The best studied adult stem cell is the hematopoietic stem cell (HSC).

The interest of transfusion medicine for HCS, concern the possibility of collecting hematopoietic stem cell and transplant in recipients for the treatment of several major blood diseases. HSC transplantation is an effective therapy for a wide variety of neoplastic diseases, in addition to congenital and autoimmune disorders.

The HCS donors can be the recipient (autologous donor) or, more frequently, a related or unrelated HLA compatible (allogeneic donor).

In autologous HSC transplantation, chemotherapy and/or radiation are administered to the patients, so, prior to HSC transplantation, patients undergo harvesting of their hematopoietic cells from bone marrow or from peripheral blood.

The allogeneic donors, typed according to international standards (IBMDR, EFI, JAICE), are inserted in international directors (donor banks) and made available for donation only after research of "perfect" HLA match with the recipient. (*Shizuru 2005*)

The HCS can be obtained by removal of bone (classic donation in use since the 60s) or peripheral blood after adequate "mobilization" from bone HCS with growth factor G-CSF (10 µg/kg sc) and collecting in apheresis or by placental/cord blood.

Before 1990, almost all HSCs transplantations were bone marrow-derived. At the end of the 1980's the first case of allogeneic peripheral blood stem cell (PBSC) transplantation was reported. Since the donor was not mobilized by cytokines, he underwent ten aphaeresis to harvest a sufficient stem cell number. Engraftment was successful. In 1988, the ability of granulocyte-macrophage colony stimulating factor (GM-CSF) and granulocyte colony stimulating factor (G-CSF) to mobilize HSCs to the blood stream was documented. Mobilization with either chemotherapy and/or growth factors injection may result in an efflux of HSCs out of the bone marrow into

the blood and lead to a concentration of HSCs in the peripheral blood that equals or exceeds the concentration in the bone marrow itself. An HSC-enriched cell fraction can then be collected by aphaeresis from the blood. In 1995, the first series of G-CSF-mobilized stem cell allogeneic transplantations was published. (*Vaglio 2005*)

The amount of HCS changes according to the type of source: the increased amount of HCS is contained in the bone (up to 3%), followed by the cord blood (up to 1%) and finally from the peripheral blood (up to 0.1%). However, today the most common sampling is from peripheral blood because, after stimulation with G-CSF, the amount of HCS increases considerably exceeding the amount contained in the bone and is less invasive

Autologous and allogeneic HSC transplantations are used, depending on donor availability and the type of treated disease.

The principle behind allogeneic HSC transplantation differs, as do the spectrum of diseases treated and the potential benefits and complications.

Compared to autologous HSC, allogeneic HSC transplantation has a higher incidence of treatment related morbidity and mortality, particularly because it contains immune cells that can respond against host-specific antigens and causes the syndrome called graft-versus-host disease (GVHD). Despite the prophylaxis with immunosuppression, 20-30% of allogeneic HSC transplantation patients develop an acute form of GVHD, and 50% develop a chronic form of the disease. If we put together the risk of GVHD, immunosuppression, and the potential failure engraftment, the transplantation-related mortality for an allogeneic HSC transplantation is 10-15%. (*Vaglio 2005*)

Under standard conditions, donors and recipients are matched at the genes of the human leucocyte antigens (HLA).

However, identify suitably matched related or unrelated donors can be difficult in some patients and alternative sources of stem cells have been explored. Cord blood provides a readily available source for such patients. The collection of cord blood cells



is relatively easy and the risk of severe acute graft-versus-host disease (GVHD) is lower.

Data accumulated over the past several years have demonstrated that cord blood is an accepted alternative source for hematopoietic stem cells in children. It offers many practical advantages such as:

- 1) absence of risk for mother and newborn;
- 2) relative ease of procurement and availability (as stored cord blood cells are fully tested and HLA-typed, they are available for immediate use);
- 3) potential reduced risk of GVHD.

While the clinical data is encouraging for pediatric patients, cord blood use can be more problematic in adult patients since the limited number of hematopoietic progenitors and the collection can occur only in a single occasion. Nevertheless cord blood transplantation has recently been explored in an increasing number of adult patients. The reason is that, while the total numbers of mononuclear cells are limited, the progenitor content and the proliferative potential of cord blood cells are high. So some protocols are now available to attempt to use cord blood as an alternative source of hematopoietic stem cells for allogeneic transplantations for adult patients too. *(Tokiko et al 2014)*

The possibility to purify and expand HSCs has recently led to the implementation of non-hematological clinical trials, aimed at developing tissue repair protocols in chronic-degenerative disorders as Alzheimer's disease, Parkinson's disease and other neurological disorders; it has opened up new and unexpected therapeutic perspectives also in the treatment of nephropathies (kidney transplantation), and other diseases involving liver, brain and heart. For example the infusion of autologous bone marrow stem cells in the coronary artery has been proposed for regenerating the myocardium after ischemia.

#### **1.2.4 Blood groups and molecular biology**

Molecular biology has been extensively applied in characterizing the genetic basis of blood group systems and developing clinical diagnostic tools for immunohematology and transfusion medicine. The discovery of the molecular basis of most red cell antigens, combined with advances in molecular testing, have paved the way for the use of genotyping to predict the red cell phenotype.

Genotyping offers many advantages over serologic testing of recipient blood with the primary benefit to predict the blood group phenotype in situations that do not permit this serologically. For example, alloantibodies develop in approximately 2-4% of people after transfusion, with a higher rate (20-40 %) among chronically transfused patients such as those with sickle cell anemia or thalassemia. Using hemagglutination to phenotype red blood cells from a person with alloantibodies can be complex and the results can be difficult to interpret. In these cases, genotyping helps to predict the red cell antigen type and provides a more complete characterization of the blood type. (*Flegel 2011; Denomme et al 2008; Hilleyer et al 2008; Westhoff 2008; Avent 2009*)

Given the large number of known genetic events that silence or weaken the expression of antigens encoded by an allele, it will be a long time before all relevant nucleotide changes are revealed for all blood group systems in all ethnic groups. For these reasons, care must be taken when using molecular methods as the serological problem may involve the inheritance of a null allele, a hybrid gene or a new variant.

In this context, the analysis of blood group variants is very important to predict a red cell phenotype using molecular methods.

Today, typical clinical applications for blood group genotyping are performed for RH, ABO and other protein based blood group systems.

The methods for *ABO* and *RH* based on modular PCR with sequence specific priming (PCR-SSP) brought about the first commercial blood typing kits, which are still available today.

## **Genetics of the ABO**

ABO was the first blood group system to be described and applied to clinical practice. While ABO is also the first blood group system defined at the gene level, the earliest clinical genotyping for any blood group system was published on *RHD* (Flegel 2013).

The genetics of the ABO blood group system was first described in by Bernstein 1924 as consisting of a set of three allelic genes, A, B and O, at a single genetic locus. In 1976, the chromosomal assignment of the ABO locus was mapped to the region 9q34.2 at the distal end of the long arm of chromosome 9.

The genes direct the occurrence and location of A and B antigens; however, the products of the genes are not the antigens themselves, but the enzymes (glycotransferases) that contribute to the production of the A and B antigens.

The genes that direct A and B antigen development are at three separate loci: ABO, Hh, and Se.

Three common alleles (A, B and O) are located at the ABO locus on chromosome 9 at 9q34.1-q34.2, and the genes at the other two loci, Hh and Se, are closely linked on chromosome. Hh and Se loci each have two recognizable alleles, one of which has no demonstrable product and is considered an amorph. (Flegel 2013).

The active allele at the H locus, H, produces a glycosyltransferase that acts at the cellular level to form the antigen on which A or B is built. The amorph, h, is very rare with a prevalence of 0.004 percent. (Flegel 2013).

The Se gene is responsible for the expression of H (and indirectly responsible for the expression of A and B) on the glycoproteins in epithelial secretions such as saliva. Secretors inherit the Se gene; and their secreted glycoproteins express H, which can be converted to A and/or B antigen if the A and/or B gene is/are also present. The amorph is called se.

The H locus encodes a fucosyltransferase that produces the H antigen on RBCs, which is an essential precursor to the ABO blood group antigens.

The *A* gene, encodes a glycotransferase that bonds a-N-acetylgalactosamine to the D-galactose end of the H antigen and produces the A antigen.

The *B* gene, similarly, determines the presence of the B antigen by encoding a glycotransferase that joins a-D-galactose to the D-galactose terminal sugar of the H antigen, creating the B antigen.

The *O* gene does not produce a functional protein; and in the heterozygote with an *A* or *B* gene, has little influence on the expression the A or B antigen. Thus, phenotypically, the *O* gene is recessive, and the *A* and *B* genes are codominant (*Table 2*). *A* and *B* genes differ from one another by seven single-base substitutions, which result in four possible amino acid substitutions (at positions 176, 235, 266 and 268) in the protein sequence of the A and B transferases. All variant A and B phenotypes, which have a weaker expression of the A and B phenotypes (subgroups), have been shown to be mutations of the *A* or *B* gene, resulting in less effective transferase production. Multiple polymorphisms have been shown in the non coding regions of genomic sequences of the ABO alleles, and these sequence variations can affect A and B antigen expression resulting in weak ABO phenotypes. A single base deletion in the O allele shifts the codon reading frame and is responsible for the loss of activity of the A glycotransferase. (*Flegel 2013*).

Group	Possible Genotypes
O	<i>OO</i>
A	<i>AA, AO</i>
B	<i>BB, BO</i>
AB	<i>AB</i>

*Table 2.* Genotypes of the ABO Blood Groups

The molecular mechanism influencing the *ABO* alleles gene expression are three groups: (i) *epigenetics*; (ii) *epistasis*; and (iii) *molecular genetics*. Blood group antigens in general and the *ABO* antigens in particular are prime examples for researching such mechanisms in the era of genomics and for utilizing the knowledge in clinical applications. DNA methylation, as one of the epigenetic mechanisms, has been shown to occur in the *ABO* gene: hypomethylation of CpG islands in the *ABO* gene promoter was associated with the expression of the *ABO* antigens in cell lines (Yamamoto *et al* 2012).

Second, epistasis, the modification of a phenotype of one gene by another gene, has been known in *ABO* since 1952, when Bhende *et al.* showed in 2 patients and 1 donor that the *ABO* antigens were not expressed, because another gene product was lacking. This other gene became known as H transferase along with its extensive allele polymorphism. (Kominato *et al* 1999).

Third, molecular genetics mechanisms explain the vast majority of blood group antigens, caused by genetic variation in exons or in other parts of the gene. In fact, the single nucleotide deletion in exon 6 of the *ABO* gene resulting in the lack of A and B antigen expression and the phenotype blood group O, was the first example of a genetic variant shown in any blood group gene (Yamamoto *et al* 1990). Today, several hundred examples of genetic variations in exons are known to affect gene expression among the 33 blood group systems. Genetic variations in gene segments other than the exons, such as the promoter, 5' and 3' untranslated regions and the introns, are observed less commonly, yet are equally important. Current examples are a tissue (erythroid cell)-specific factor binding to the *ABO* promoter and an enhancer protein binding *ABO* intron 1, which control the expression of the *ABO* gene (Sano *et al* 2012)

## **Genetics of the RHD**

There are now 51 antigens within the Rh system and more than 200 alleles for the *RHD* gene alone. *RHD* zygosity has been resolved, epitopes have been mapped, and many D variants with altered antigens have been identified.

Based on the homology of Rh polypeptides to the ammonia transporter AmpB, computational analyses have modeled the 3D structure of the RhD polypeptide to learn about additional potential functions of Rh polypeptides. The reason for this interest is that *RHAG*, a gene located on chromosome 6 (6p11–p21), shares an identical exon structure and major regions of sequence identity with *RHD/RHCE* (Carton *et al* 2001).

To date, the function of RhD and RhCE appears associated with membrane integrity, and possibly transport of gases like carbon dioxide. RhAG may contribute to gas exchange across the plasma membrane, and its mutations are associated with hereditary stomatocytosis (Marini *et al* 2000). Thus, expression of Rh polypeptides and associated proteins is complex, and molecular discoveries have broadened our understanding of this important blood group system.

Regard to genetics aspects, RH is a bigenic locus comprising *RHD* and *RHCE* positioned in a tail-to-tail orientation toward the end of the short arm of chromosome 1 (p34–36). Another gene, *SMP1*, is interspersed between both *RH* genes in close proximity to the 3' end of *RHCE*. Identification of the single murine equivalent in the mouse genome project provided evidence that *RHCE* evolved from the ancestral *RH* on the basis of the position and orientation of murine genes in the region (Fig.8). Therefore, *RHD* arose from a duplication event that predates modern humans. (Blancher 2000)

During the duplication event, and possibly associated with its cause, two approximately 9,000 base-pair-long homologous repeat sequences, termed *Rhesus boxes*, were likely introduced that flank the *RHD* gene in the genomes of modern humans. *RHD* was lost from the genome through unequal crossing over involving the

*upstream Rhesus box* and *downstream Rhesus box* (Fig. 9), an event that may have occurred more than once.

The tail-to-tail orientation may facilitate the large number of alleles; the identification of corresponding nucleotides in both genes suggests that most hybrid alleles arise through gene conversion events (Fig. 10)

*RHD* and *RHCE* share regions of identity, with the translated RhD polypeptide differing at up to 36 amino acid positions depending on which RhCE polypeptide it is compared. Both Rh polypeptides comprise 12 transmembraneous protein segments and 6 extracellular /intracellular loops (Fig. 11).

Historically, serologic studies classified the D antigen into six major categories (DII through DVII, with DI being obsolete). Three epitope models were proposed comprising 9-epitopes or 37-epitopes or the combination of both based on the serological reaction pattern of more 80 monoclonal anti-D antibodies. (Lomas *et al* 1989; Scott 1996).

Many variants express altered D antigen, but no absolute correlation exists between phenotypic expression and clinical relevance of *RHD* alleles. *RHD* alleles have been classified on the basis of their phenotypic relationship to the molecular variation: partial D, weak D types, DEL, and nonfunctional alleles.(Daniels 2002; Reid *et al* 2003). More than 200 *RHD* alleles have been reported and may be grouped according to serological and molecular features (Table 3).

The classification of partial D variants is based on the premise that certain amino acid substitutions on an extracellular loop affect linear D epitopes or, more often, the 3dimensional conformation of that loop. Many partial D are identified using monoclonal antibodies that target specific domains or loops on the surface of the erythrocyte.

The D categories (DII to DVII) represent a subset of all partial D. DII and DVII are caused by single extracellular amino acid substitutions, while DIII, DIV, DV, and DVI are caused by *RHD-CE-D* hybrid alleles and comprise several subtypes each. The

classification as partial D is of clinical relevance because carriers often produce anti-D upon exposure to the normal D antigen (*Rouillac 1995*).

However, for many partial D, anti-D immunization events are apparently rare, and for several partial D there has been no observation of any patient with anti-D so far. These facts are compatible with the conclusion that carriers of several distinct partial D may be at a very low or no risk of anti-D immunization.

A weak D type is a variant of the RhD protein that comprises an amino acid substitution located in the transmembraneous or intracellular segments and expresses a reduced amount of D antigen (generally less than 5,000 D antigens per RBC). A group of 16 distinct weak D types were described originally, but the total number of weak D types including their subtypes now exceeds 80.

The substitutions are thought to cause folding problems during integration of the protein into the RBC membrane, which can impede protein integration, affecting palmitoylation or anchoring of the polypeptide to the RBC cytoskeleton. Hence, the amount of D antigen expressed on the RBC surface is quantitatively reduced, but the D antigen itself remains, by-and-large, qualitatively unchanged. Therefore, the normal D antigen is not usually immunogenic (*Wagner et al 1999; Gane et al 2001*).

Like the mentioned exception for several partial D that cannot be immunized, there is an exception for some weak D types. Anti-D immunization in weak D carriers is rare, but there are exceptions: examples include weak D type 15, weak D type 4.2, also known as DAR, and weak D type 7.

The weak D types 1, 2, 3, and 4.0/4.1, which are the most prevalent in any European and Caucasian population, represent more than 95% of all weak D types. To date, more than 10 years after their molecular description, the literature has not documented any carrier of weak D types 1 through 4.1 being alloimmunized and producing allo-anti-D (*Ansart Pirenne et al 2004; Legler et al 2001*).



Those observed produce low titer antibodies of autoantibody nature. The observation that the common weak D types fail to make allo-anti-D is particularly relevant in the prevention and management of anti-D alloimmunization in pregnancy.

A very weakly expressed D antigen is called DEL (formerly D) because it was originally detected only if anti-D adsorbed and then eluted from RBCs.

Typically, RBCs with DEL express 200 or fewer copies of the D antigen per RBC. The most common DEL is caused by the *RHD*(K409K) allele harboring the C1225A nucleotide substitution in exon 9. Because it is very prevalent in D negative Asians, it has been dubbed the “Asian type” DEL. This substitution is a silent single nucleotide polymorphism (SNP), the amino acid lysine (K) at position 409 remains unchanged. However, the substitution causes missplicing mRNA such that the complete full messenger mRNA has never been documented and at most represents a very minor form of transcript for translation. (*Wagner et al 2001*)

Even combined, all DEL phenotypes are rare in Europeans. Up to 30 % of seemingly D-negative East Asian people carry the DEL *RHD*(K409K), but other *DEL* alleles are also more frequent in Asia than in Europe.

DEL is of interest worldwide because of its potential to cause anti-D alloimmunization when DEL-positive blood donors are inadvertently labeled as D negative.

In addition, *DEL* alleles can cause genotype-phenotype discrepancies and should be taken into consideration when fetal blood group genotyping methods depend on the ethnicity of the parents. The fetal inheritance of DEL would not be considered a risk of hemolytic disease of the fetus and newborn (HDFN). (*Flegel 2005*)

The most common D negative haplotype in all populations is caused by the deletion of the whole *RHD* gene with the concomitant presence of the *hybrid Rhesus box* (*Fig. 9*). However, other D negative haplotypes exist.

Some individuals who are D negative can harbor a nonfunctional *RHD* allele. One of the first nonfunctional *RHD* alleles was termed *RHD* pseudogene (*RHD*ψ).

Both nonfunctional alleles occur rather frequently in African populations. Less common D negative alleles are caused by a host of different hybrid *RHD-CE-D* alleles or nonsense and frame shift mutations. It is important to note that the distinction between apparent D negative and DEL phenotypes by serology may be somewhat arbitrary. But the clinical significance is not: DEL blood transfused to D negative transfusion recipients is immunogenic, and the common “Asian type” DEL is not prone to making anti-D after its carrier is transfused with normal D positive RBC units. Therefore, in Asian populations, in whom D negative blood is rare, identifying DEL transfusion recipients (approximately 1/3 of all serological D negative) could significantly reduce the demand for Rh-negative blood (*Daniels et al 1998; Singleton et al 2000*)

Rh null. The lack of both RhD and RhCE proteins may be caused by the inheritance of two nonfunctional *RHCE* alleles in the background of an *RHD* deleted haplotype. This constellation gives rise to the amorph type Rh phenotype (lack of any Rh protein), in which neither D nor CE antigens are expressed null. Alternatively, because the expression of either Rh protein requires the presence of RhAG for appropriate assembly on the RBC membrane, defects in *RHAG* alleles cause the lack of both RhD and RhCE proteins. This biological background explains why defects in *RHAG* alleles cause the regulator type Rh phenotype (lack of expression of Rh protein), in which D and CE antigens may be undetectable but are in principle expressed. Rh null alloimmunization in pregnancy can be extremely difficult to manage in the setting of HDFN, largely due to the lack of compatible allogenic blood. Maternal blood has been used as a source of blood for the fetus and neonate (*Kato Yamazaki et al 2000*)

RhCE variants. Partial antigens have been reported for the common RhCE antigens; C, c, E, and e, although several *RHCE* alleles have been characterized and many other alleles may exist. As with partial D, carriers of partial CE antigens can

make antibodies to epitopes that are missing on the variant RhCE protein. Unlike *RHD*, *RHCE* is not often deleted.

Therefore partial CE antigens are less obvious from serology, because they are covered by the regular RhCE protein from the second chromosome. Few people carry these variants, which is one reason that alloimmunization is uncommon. The clinical relevance of RhCE variants may be more appreciated once molecular analysis allows deeper insight into their associated immunization events, like, for instance, in sickle cell disease (SCD) patients, in pregnancies, and in chronically transfused patients (*Tournamille et al 2010*).

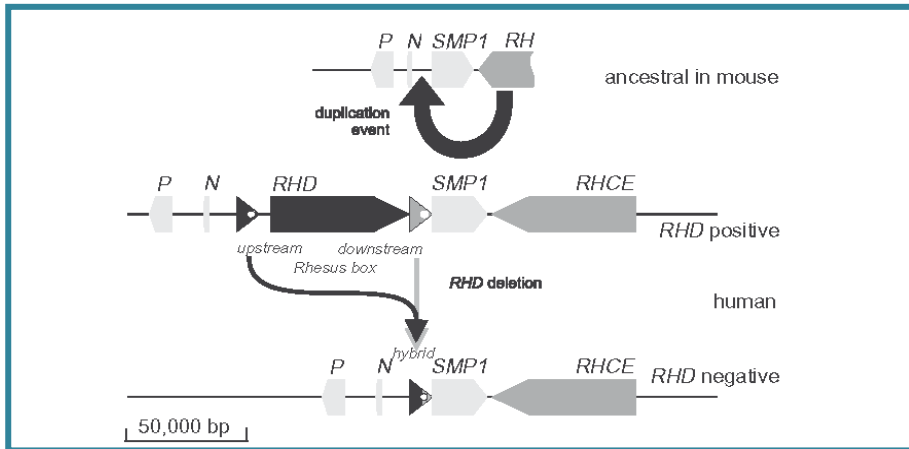

W.A. Flegel/Transfusion and Apheresis Science 44 (2011) 81–91

**Fig. 8: Duplication of the *RH* gene and loss of the *RHD* gene:**The ancestral configuration is shown as represented by the *RH* gene locus in mouse. The single *RH* gene is in close proximity to the three genes *SMP1*, *P29-associated protein (P)*, and *NPD014 (N)*. A duplication event introduced a second *RH* gene in reverse orientation between *N* and *SMP1*. At the two break points in front and behind the *RHD* gene, DNA segments of approximately 9,000 base pairs (bp) occur. Both DNA segments are flanking the *RHD* gene and dubbed "upstream Rhesus box" and "downstream Rhesus box". In the *RHD* positive haplotype, the *RHD* gene may have been lost by a recombination event (see Fig. 10).

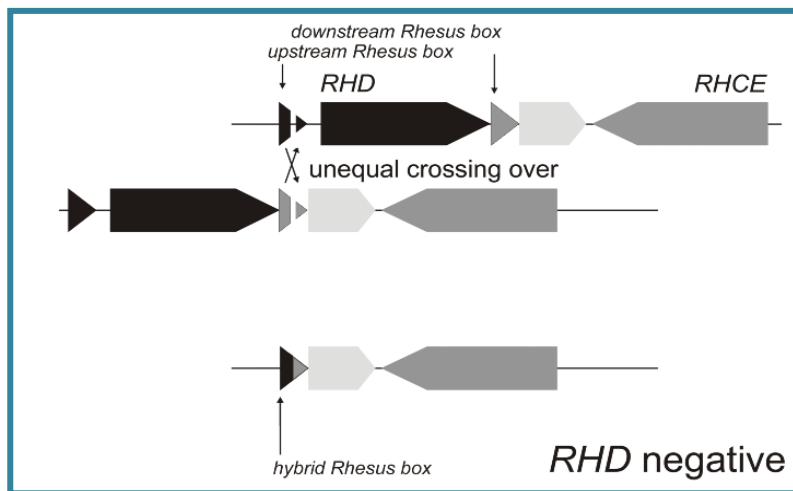

W.A. Flegel/Transfusion and Apheresis Science 44 (2011) 81–91

**Fig. 9. *RHD* deletion** An unequal crossing over event between an upstream Rhesus box and a downstream Rhesus box caused the *RHD* deletion. If one of the two crossed-over chromosomal threads are resolved, an *RH* gene locus results that lacks the *RHD* gene completely and harbors a hybrid Rhesus box.

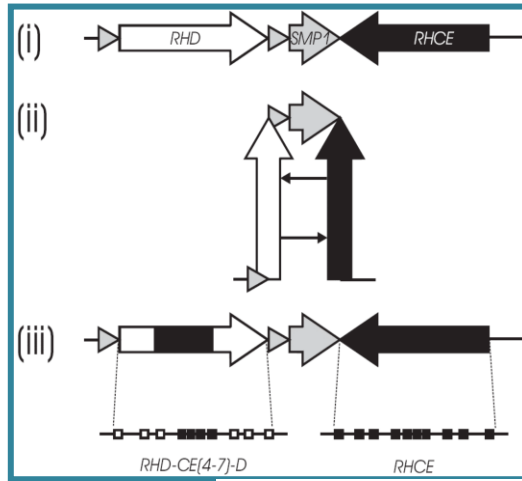

W.A. Flegel/Transfusion and Apheresis Science 44 (2011) 81-91

**Fig. 10. RHD/RHCE hairpin formation**

The schematic diagram depicts the mechanism of gene conversion at the Rhesus gene locus on one chromosome. (i) The *RHD* and *RHCE* genes are inversely orientated, which is typical for clustered genes. (ii) A hairpin formation of the chromosome would generate the close proximity of homologous segments in identical orientation. This structural feature is generally instrumental in gene conversion events *in cis*. (iii) Resolving the hairpin yields an *RHD-CE-D* hybrid gene structure, many of which have been observed to date at the *RH* gene locus.

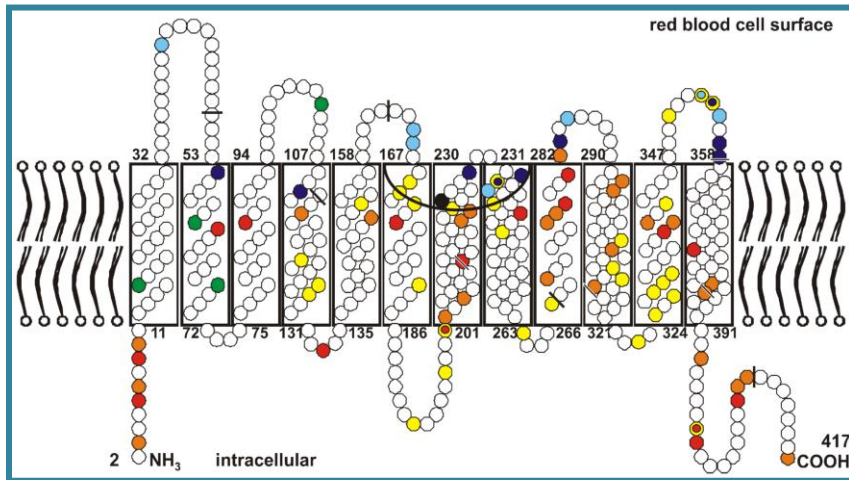

W.A. Flegel/Transfusion and Apheresis Science 44 (2011) 81-91

**Fig. 11. Model of Rhesus proteins in the red blood cell membrane**

Both Rhesus proteins comprise 417 amino acids, shown here as circles. Mature proteins in the membrane lack the first amino acid. The amino acid substitutions that distinguish the RhCE from the RhD protein are marked in yellow, with the 4 amino acids that code for the C antigen in green and the one that codes for the E antigen in black. The single amino acids substitutions which code for partial D are in blue, and those that code for weak D are in red. The mutations that had been identified at the Ulm Institute since 1999 are in light blue and orange. The extracellular Rh vestibule is depicted by the inverted black arc and bordered in part by amino acids of loops 3 and 4. The nine exon boundaries in the *RHD* cDNA, as reflected in the amino acid sequence, are indicated by black bars.

classification of antigen variation	D antigen Phenotype	molecular basis		representative example		novel Rhesus antigen
		protein variation	Mechanisms	RHD allele	trivial name	
partial D	qualitative change	amino acid substitution on the RBC surface	missense mutation	<i>RHD</i> (G355S)	DNB	Unknown
		protein segment exchange on the RBC surface	gene conversion (hybrid protein)	<i>RHD-CE</i> (3-6)- <i>D</i>	DVI type 3	BARC
weak D	quantitative change	amino acid substitution in the membrane or intracellularly	missense mutation	<i>RHD</i> (V270G)	weak D type 1	Unknown
DEL	major quantitative change	grossly reduced translation or protein expression	missense mutation mutation at splice site	<i>RHD</i> (M295I) in <i>CDe</i> <i>RHD</i> (K409K)	not applicable	unknown
D negative	D negative	lack of protein expression	gene deletion	<i>RHD</i> -Deletion	D negative	unknown
			nonsense mutation	<i>RHD</i> (V330X)	not applicable	unknown
			Frame shift mutation	<i>RHD</i> (488del4)	not applicable	unknown
			modifying gene	defect of <i>RHAG</i> gene	Rh <sub>null</sub>	unknown
		protein segment exchange on the RBC surface	gene conversion (hybrid protein)	<i>RHD-CE</i> (3-7)- <i>D</i>	c <sub>del</sub>	Unknown
antithetical antigens of the RbCE protein	expression of antigen E or antigen e	amino acid substitution on the RBC surface	missense mutation at amino acid position 226 in <i>RHCE</i>	<i>RHCE</i> allele: Ala226 coding antigen e Pro226 coding antigen E	not applicable	E versus e

W.A. Flegel/Transfusion and Apheresis Science 44 (2011) 81–91

Table 3. Representative molecular changes in *RHD* alleles expressing distinct phenotypes of the D antigen

## 2. AIM OF THE THESIS

The transfusion medicine history transformed its connotations through the millennia: from magic and esoteric practice of the ancient peoples, becomes today a fascinating scientific reality with multiple areas of action.

The improvements of the last decades have created many fields of interest to the scientific community and radically changed the Blood Transfusion Service work.

As witnessed by the numerous scientific sessions of the national and international conferences in recent decades (SIMTI, ISBT), together the historical transfusion activities involving the processing and banking blood, there is a strong interest in new activities able to open new and avant-garde borders in public health.

The scientific discoveries and technologic advances that in the last 50 years have transformed transfusion medicine and blood banking are reported in *table 4*:

---

### Transfusion Medicine Improvements

- *Apheresis technology*
- *Marrow and hematopoietic stem cells*
- *RBC antigen and alloantibodies*
- *The role of WBC*
- *Plt and neutrophil antigens and antibodies*
- *Volunteer blood donors*
- *Blood safety*
- *Hematopoietic growth factors*
- *Plasma derivatives*
- *Blood utilization and managements*
- *Blood groups and Molecular Biology*

*Table 4.* Transfusion Medicine Improvements: key scientific discoveries and technologic advances in blood banking and transfusion medicine

Thus the aim of my PhD was investigate knowledge focusing on molecular and cellular basic and applied aspects of Immunohematology and Transfusion Medicine.

Regard transfusion medicine, the application aspects related the *transfusion approach to Moschcowitz syndrome* (TTP or thrombotic thrombocytopenic purpura) and the role of *regenerative medicine in osteoarticular injury*.

The first was a pathophysiological and clinical study of four clinical cases of patients affected by TTP and treated with plasma exchange, in the light of the therapeutic role of plasma therapy in this syndrome and the most recent etiopathogenesis knowledge of the disease. TTP is characterized by disseminated thrombotic microangiopathy associated with haemolytic microangiopathic anaemia. The pathogenesis is closely related to von Willebrand factor (VWF) since there were unusually large or ultralarge multimers of VWF (ULVWF) in the circulation of patients. Some severe forms of TTP seem to be related to ADAMTS 13 plasma reduction. ADAMTS 13, a plasma reprotolysin-like metalloprotease, cleaves VWF and attenuates arterial/venous thrombosis after oxidative injury. The more distal portion of ADAMTS-13 (TSP1 2–8 repeats and CUB domains) may function as a disulfide bond reductase to prevent an elongation of ultra-large VWF strings on activated endothelial cells and inhibit platelet adhesion/aggregation on collagen surface under flow. Remarkably, the proteolytic cleavage of VWF by ADAMTS-13 is accelerated by FVIII and platelets under fluid shear stress. A disruption of the interactions between FVIII (or platelet glycoprotein 1ba) and VWF dramatically impairs ADAMTS-13-dependent proteolysis of VWF in vitro and in vivo. These results suggest that FVIII and platelets may be physiological cofactors regulating VWF proteolysis. Finally, the structure–function and autoantibody mapping studies allow us to identify an ADAMTS-13 variant with increased specific activity but reduced inhibition by autoantibodies in patients with acquired TTP. Together, these findings provide novel insight into the mechanism of VWF proteolysis and tools for the therapy of acquired TTP (*Zheng et al 2013*).

The second application regards the role of regenerative medicine in osteoarticular injury, in particularly the effect of the platelet gel application in orthopedics was



studied. The platelets gel has a positive effect in tissue repair because effective accelerate the healing process of osteochondral, muscle, tendon and ligament lesions. In fact, platelets produce, store, and, if activated, release growth factors or GFs (VEGF, PDGF, FGF, EGF, HGF, IGF)) capable of several function as: inducing the replication of mesenchymal cells, exerting chemotactic action towards the inflammatory cells (polymorphonuclear leukocytes, monocytes, and macrophages), stimulating the release of proteases responsible for tissue remodeling. Therefore, platelet key role in the inflammatory process (due to high concentrations of pro-inflammatory or immune- modulatory cytokines), in the antimicrobial defense (since the  $\alpha$ - granules are rich 15 in "protein microbicide platelet", chemokines -CXCL4, thymosin- $\beta$ 4, derivatives of CXCL7- PBP, CTAP - III, 16 NAP- 2 and CCL5 -6 and complement proteins), in cell replication (mitogenesis), in angiogenesis and actively modulate tissue regeneration (*Lucarelli et al 2003*).

The basic aspects of classical Immunohematology were related to the *role of ABO antigens in aging* and to the *study of allelic variants of the antigen RhD*.

Regards the role of ABO antigens in longevity were reanalyzed data from a previous pilot study performed by our group and conducted on Sicilians centenarians (*Vasto S, Caruso C, Castiglia L, Duro G, Monastero R, Rizzo C. Blood group does not appear to affect longevity a pilot study in centenarians from Western Sicily. Biogerontology. 2011 Oct;12(5):467-71*). Centenarians are the best example of extreme human longevity, and they represent a selected population in which the appearance of major age-related diseases, such as cancer, and cardiovascular diseases, has been consistently delayed or escaped. The study of the long-lived individual genetic profile serves to identify the genes and the allelic variations influencing extended life expectancy. The aim of the study was tried to attempt a possible connection between the histo-blood group ABO and life expectancy, because the ABO phenotype was one of the first marker to be typed both for studying disease and ageing (*Aird et al 1953; Murray 1961*). The observed data showed a not-significant increase

of A1 allele in Sicilian centenarians. It is very interesting because literature shows that levels of serum soluble E-selectin (inflammatory marker of several diseases, cardiovascular included), are higher in O/O individuals, whereas a single nucleotide polymorphism in A1 allele is associated with low levels of these inflammatory markers. So, A1 allele increase in Sicilian centenarians, due to low levels of inflammatory mediators, might be related to the protection from adverse cardiovascular events.

In the light of these data and of the evidences that the ABO blood antigens might play a key role in various human diseases, we reviewed the literature to study in deep the possible association of ABO group with age-related diseases and longevity taking into account the biological role of the ABO glycosyltransferases on some inflammatory mediators as adhesion molecules.

The *study of allelic variants of the antigen RhD* was started at the Transfusion Service of AOUP “Paolo Giaccone” to perform the biomolecular analysis of all samples serologically identified as D variant or Du.

The daily activity of serology laboratory, not distinguish an antigenic expression weak quantitative (weak D) from a qualitative (D Partial). This may be clinically significant in transfusion practice or prevention of HDFN.

Therefore, after confirming the importance of bimolecular evaluation of donors and patients referred to our service transfusion, the project was approved by the President of SIMTI, Ph. Claudio Velati (*fig 12*) and was proposed to the transfusion services in the Province of Palermo to start an epidemiological study of allelic variants of RHD. The purpose of this analysis was to assess the impact of the phenomenon on the study population and map genotypes recurring.

Considered the low incidence of samples RHD variant, the study is still in progress and is not yet complete recruitment of the samples. The partial analysis of the results obtained until now, has shown that the incidence of the D variant forms (0.12%) is slightly lower than described in literature for the general population (0.2-1%) and that,

unexpectedly, the sample observed shows a high prevalence of weak samples 5 and 11, usually less common. This shifts the focus on genetic differences of the different ethnic groups to be found in the natural history of the Sicilian population.

Furthermore, the observation of D variant compared to genotype RHCE highlights the constant association of forms Dvariant with a genotype RHCE that always determines the expression of C or E. These suggest that the RHD gene variant expressions may be related or dependent by trans position of RHE /C. These data give a new study perspective oriented to a proteomic analysis.

Another applicative aspect of transfusion services laboratory activities, concerns the HLA typing for stem cells and cord blood cells banking or for the study of platelet and erythrocyte reactivity. The new literature, data show a clear correlation between HLA and leukemia. In our Transfusion Service, the leukemia patients represent the largest sample of receiving blood and platelets and more exposed to the risk of alloimmunization. Then was made a literature review for preliminary correlation study between HLA and leukemia.

HLA plays a central role in immune surveillance, and HLA polymorphisms may impact the ability of the immune system to identify malignant cells and target them for T cell-mediated elimination. HLA class I proteins (HLA-A, -C, and -B) present peptides from endogenous proteins to cytotoxic T lymphocytes. HLA class II proteins (HLA-DRB3/4/5, -DRB1, and -DQB1) present peptides derived from exogenous proteins to CD41 helper T cells.

With regard to the possible role of HLA molecules in leukemia, a causative role of HLA in terms of presentation of a nonself-peptide (i.e. virus) or altered self-peptide (i.e. a mutated oncogene) is a possibility. However, this effect might be mediated by NK cells, known to control tumor transformation and viral infection. In fact, HLA class I antigen, in particular HLA-C alleles, play a role as KIR ligands that play a crucial role in the activity of natural killer cells (*Gragert et al 2014*)



S I M T I

SOCIETA' ITALIANA di MEDICINA TRASFUSIONALE  
e IMMUNOEMATOLOGIA

00185 ROMA – Via Principe Amedeo 149, scala D

Roma, 26 luglio 2012  
Prot.n.292/12/CV/Prog.ricerca

Egr. Prof.  
**Calogero Caruso**  
Coordinatore  
Dottorato di Ricerca in Medicina Molecolare  
Università degli Studi di Palermo  
Palermo

Oggetto: Progetto di ricerca "Studio epidemiologico genetico delle varianti alleliche del Sistema Rh tra i donatori e i riceventi afferenti ai Servizi di Medicina Trasfusionale della provincia di Palermo"

Egregio Prof. Caruso,

La ringrazio per la Sua nota in merito all'avvio di uno studio epidemiologico sul sistema Rh presso la Vostra Università.

L'argomento rientra sicuramente tra quelli classici della Immunoematologia ai quali è dedicato l'interesse di questa società scientifica: auguriamo, pertanto, la piena riuscita del progetto che vede la Dott.ssa Claudia M. Rizzo, come Responsabile scientifico, e ci auguriamo di poter avere un riscontro dei risultati di tale lavoro anche ai fini di una sua possibile pubblicazione sulla nostra rivista "Blood Transfusion".

Con i più cordiali saluti.

Dott. Claudio Velati  
Presidente SIMTI

Tel. 06 44 52 669 – 06 44 52 751  
Fax 06 44 41 439  
www.simti.it  
e-mail : [sesteria@simti.it](mailto:sesteria@simti.it)

Codice Fiscale  
80294740588  
Partita IVA  
03664721005

Fig. 12. The epidemiological study of allelic variants of the RHD, was approved by the President of SIMTI, Ph. Claudio Velati

**3. Thrombotic thrombocytopenic purpura: a review of the literature in the light of our experience with plasma exchange**

## Thrombotic thrombocytopenic purpura: a review of the literature in the light of our experience with plasma exchange

Claudia Rizzo<sup>1</sup>, Sergio Rizzo<sup>2</sup>, Elisabetta Scirè<sup>2</sup>, Danilo Di Bona<sup>2</sup>, Carlo Ingrassia<sup>2</sup>, Giovanni Franco<sup>4</sup>, Roberto Bono<sup>4</sup>, Gerlando Quintini<sup>3</sup>, Calogero Caruso<sup>1</sup>

<sup>1</sup>Unit of Immunohaematology and Transfusion Medicine, "Paolo Giaccone" University Hospital, Department of Biopathology and Medical and Forensic Biotechnologies (DIBIMEF), University of Palermo, Palermo;

<sup>2</sup>Unit of Immunohaematology and Transfusion Medicine, "Paolo Giaccone" University Hospital, Palermo;

<sup>3</sup>Haematology and BMT Unit, "Paolo Giaccone" University Hospital, Palermo, <sup>4</sup>Haematology and BMT Unit, "Paolo Giaccone" University Hospital, Department of Internal and Specialist Medicine (DIMIS), University of Palermo, Palermo, Italy

### Introduction

Thrombotic thrombocytopenic purpura (TTP), a disease characterised by disseminated thrombotic microangiopathy associated with haemolytic microangiopathic anaemia, was described for the first time by Eli Moscovitz in 1925 as an "acute febrile pleiochromic anaemia with hyaline thrombosis of the terminal arterioles and capillaries"<sup>1</sup>. The disease is now better understood from a pathophysiological point of view even though its rarity (annual incidence of 11.3 cases per 1,000,000 population)<sup>2</sup> and the lack of specificity of the signs, symptoms and laboratory findings make its management difficult. The symptoms, as stated, are non-specific: fever, renal dysfunction (to the point of acute renal failure in some cases), fluctuating neurological disorders (mild headache, onset of behavioural anomalies, transient sensory and motor deficits, coma), possible ischaemic gastrointestinal complications (abdominal pain) and retinal detachment. More than 35% of patients do not have neurological symptoms at onset; fever and renal dysfunction are present in only a small minority of cases. The diagnosis can, therefore, be made in the presence of a microangiopathic haemolytic anaemia (with schistocytes in a peripheral blood smear), thrombocytopenia (from platelet consumption) and increased levels of lactate dehydrogenase (LDH) not due to other identifiable causes<sup>3,4</sup>.

In 1982, as a result of the need to aid the differential diagnosis in these cases, Moake *et al.*<sup>5</sup> observed that the pathogenesis of TTP is closely related to von Willebrand factor (VWF) since there were unusually large or ultralarge multimers of VWF (ULVWF) in the circulation of patients with TTP whereas these multimers were not present in patients in remission

or in healthy controls. Moake hypothesised that the patients with TTP lacked a protease capable of cleaving the ULVWF multimers to prevent the intravascular formation of thrombi. Only in 1996, drawing on the independent observations of Tsai<sup>6</sup> and Furlan<sup>7</sup>, there was an understanding of the relationship with a metalloprotease whose lack or inhibition plays a key role in the pathology of TTP<sup>8,9</sup>: ADAMTS 13, "a disintegrin-like and metalloprotease with thrombospondin repeats".

In conditions of high shear stress in the blood, the ULVWF multimers secreted by activated endothelial cells are anchored as filaments to the molecules of P-selectin exposed on the surface of the activated endothelium. ADAMTS13 regulates the length and, therefore, the thrombogenic potential of the VWF by binding to the accessible A3 domains of the VWF and breaking down the ULVWF multimers by cleaving the peptide bond between the Tyr1605-Met1606 residues in the A2 domain. As a consequence of a lack of ADAMTS13 (activity  $\leq 50\%$ ), ULVWF multimers are not broken down after being secreted by endothelial cells, but remain anchored to the endothelium. Platelets passing close by adhere through GpIb and the GpIIb/IIIa complex to the A1 and A3 domains of the monomeric subunits of the ULVWF filaments anchored to the P-selectin and form large, occlusive thrombi.

In congenital forms of TTP mutations have been found in the gene for ADAMTS 13 (located on chromosome 9q34). More than 70 mutations have been identified so far: 60% are missense mutations, while the other 40% are nonsense, frameshift or splicing mutations<sup>10,11</sup>. The disease has an autosomal recessive mode of inheritance and is usually, but

not always, manifested at birth or during infancy. The congenital cases are extremely rare (incidence 1:1,000,000) and account for a small percentage (5%) of all cases of TTP. More frequently the disease is manifested in adults as secondary TTP (in haematopoietic stem cell transplant recipients, in pregnant women, in patients with autoimmune diseases, human immunodeficiency virus infection or cancer<sup>12</sup>) or as idiopathic TTP characterised in 70-80% of cases by the presence of IgG autoantibodies (mainly IgG4) capable of inhibiting the enzymatic function of ADAMTS13 in various ways. IgG4 block the proteolytic activity of ADAMTS13 with regards to VWF, increasing the clearance of ADAMTS13 from the bloodstream, or can interfere with the interactions between ADAMTS13 and cells or other plasma proteins. The biological function of the IgG is strongly dependent on their specificity, affinity and subclass: IgG4 are produced mainly after a prolonged period of antigenic stimulation and for this reason the abundant production of IgG4 anti-ADAMTS13 autoantibodies suggests a condition of chronic antigenic stimulation of the immune system when the mechanisms of systemic immune tolerance fail<sup>14</sup>.

From a transfusional point of view, the interest in TTP is based on the possibility of treating patients with plasma exchange (PEX) with fresh-frozen plasma. Since the introduction of this treatment in the 1970s, the natural history of TTP has changed radically, with 70-80% of patients obtaining a complete remission (compared to a mortality rate of 90% in untreated patients)<sup>2</sup>. The problem with the treatment of TTP is that although 80% of patients have a complete response to therapy (*responders*), about 20% of patients relapse after successful treatment of an acute episode or are refractory to PEX with persistent thrombocytopenia and high levels of LDH after a complete cycle of treatment (at least 7 days) of PEX (*refractory or non-responders or partial responders*). The Canadian Apheresis group found that 36% of patients with TTP relapsed during a 10-year follow-up<sup>2,4,13</sup>.

### Our experience

In a 2-month period (May - July 2011) the therapeutic apheresis group at the Service of Transfusion Medicine of "Paolo Giaccone" Hospital in Palermo observed and used PEX to treat four cases of acquired TTP attending the Haematology Unit of the same hospital.

After a careful clinical evaluation, the diagnosis of TTP was made on the basis of signs of microangiopathic haemolysis, a negative Coombs' test, decreases in haemoglobin concentration and platelet count, an increase in the number of reticulocytes, the presence of schistocytes in a peripheral blood smear, and increases in the values of total bilirubin and serum activity of LDH. The diagnosis was not, however, supported by the search for anti-ADAMTS13 antibodies or an evaluation of the activity of this enzyme.

All the patients were treated with the same therapeutic regimen which, in accordance with the guidelines from the American Society for Apheresis<sup>15</sup>, consisted of daily PEX with the exchange of at least one plasma volume. The replacement fluid, which was fresh-frozen plasma and physiological saline in a ratio of 2:1, enabled 100% of the plasma volume to be exchanged in all four patients. At least nine exchange sessions were performed before achieving a normal platelet count ( $\geq 150 \times 10^9/L$ ) and LDH levels ( $\leq 300$  IU/L) on 3 consecutive days. Furthermore, each patient was treated with adjuvant corticosteroids (methylprednisolone 1 mg/Kg/die)<sup>15</sup>. The transfusion therapy consisted of infusion of red cell concentrates and platelets to enable the placement of a central venous catheter without running the risk of haemorrhage during its insertion. After normalisation of the platelet count, the PEX was suspended for clinical observation and laboratory studies. The patients were discharged only after their platelet counts and LDH levels had remained stable for 1 week (Table I).

The observation of so many patients in such a short time stimulated our group to evaluate the patients' response to treatment, in terms of normalisation of platelet count, levels of LDH and haemoglobin concentration, during and immediately after the PEX therapy.

### Case 1

A 29-year old secundipara (blood group O positive, phenotype Rh CCDee, kk) was referred to us because of a first relapse of TTP. The diagnosis had been made 18 months earlier during the woman's second pregnancy (38<sup>th</sup> week), when she was admitted to hospital because of anaemia and worsening thrombocytopenia with diffuse petechiae on the abdomen and lower limbs. On that occasion, treatment was started with steroids and an infusion of fresh-



**Table 1** - Clinical and laboratory features of the four patients with TTP

	Case 1	Case 2	Case 3	Case 4
Age (years)	29	50	54	31
Type of TTP	Relapsed TTP	Acute TTP	Acute TTP	Post-partum TTP
Blood group	O CcDde	A CcDEe	A CcDEe	A CcDEe
Disease onset	Anaemia, thrombocytopenia and petechiae of lower limbs	Anaemia, thrombocytopenia and meno-metrorrhagia	Anaemia, thrombocytopenia and petechiae of lower limbs	Anaemia, thrombocytopenia and paraesthesia
Laboratory parameters at onset	Hb 8.3 g/dL; Plt $5 \times 10^9/L$ ; LDH 3669 IU/L	Hb 8.4 g/dL; Plt $20 \times 10^9/L$ ; LDH 2180 IU/L	Hb 7.4 g/dL; Plt $23 \times 10^9/L$ ; LDH 1274 IU/L	Hb 9 g/dL; Plt $28 \times 10^9/L$ ; LDH 1588 IU/L
PEX	9 exchange sessions (2,000 mL plasma/die)	10 exchange sessions (2,200 mL plasma/die)	9 exchange sessions (2,000 mL plasma/die)	11 exchange sessions (2,200 mL plasma/die)
Plasma volume exchanged (%)	100%	100%	100%	100%
Transfusion treatment	4 units of RBC, 23 units of FFP, 2 units of Plt from apheresis	2 units of RBC, 20 units of FFP, 1 unit of Plt from apheresis	1 unit of RBC, 27 units of FFP	2 units of RBC, 16 units of FFP, 2 units of Plt from apheresis
Adjuvant treatment	methylprednisolone	methylprednisolone	methylprednisolone	methylprednisolone
Start of rituximab treatment (day of admission)	day 26	day 17	no	no
Laboratory parameters at discharge	Hb 10.5 g/dL; Plt $92 \times 10^9/L$ ; LDH 475 IU/L	Hb 10 g/dL; Plt $163 \times 10^9/L$ ; LDH 440 IU/L	Hb 11.1 g/dL; Plt $183 \times 10^9/L$ ; LDH 279 IU/L	Hb 11.4 g/dL; Plt $122 \times 10^9/L$ ; LDH 241 IU/L

frozen plasma: the woman had a complete response which enabled her pregnancy to be concluded with a delivery by Caesarean section. Following discharge from hospital, the patient had monthly follow-up assessments for 6 months with apparent resolution of the disease. The relapse started with a fever (lasting 1 week) with considerable weakness followed by the appearance of petechiae on the lower limbs and pathognomonic laboratory evidence of recurrent disease (platelet count  $5 \times 10^9/L$ , Hb 8.3 g/dL) together with increased indices of haemolysis and renal function (total bilirubin 3.91 mg/dL, LDH 3669 IU/L, AST/ALT 48/31 IU/L, creatinine 1.7 mg/dL), a negative Coombs' test and six to seven schistocytes per field in a peripheral blood smear.

A therapeutic protocol of PEX was started immediately and, in relation to her own plasma volume, the patient's plasma was exchanged with 2,000 mL of fresh-frozen plasma/die (percentage of plasma volume exchanged: 100%) for 9 days until her platelet count and haemoglobin concentration reached levels compatible with resolution of the dyscrasia and haemolysis (platelets  $\geq 140 \times 10^9/L$ , Hb  $\geq 10$  g/dL, total and direct bilirubin  $\leq 1$  mg/dL).

Eight days after suspension of PEX the disease

recurred with a new decrease in the platelet count (platelets  $52 \times 10^9/L$ ), so the patient was treated with rituximab 600 mg (Figure 1).

#### Case 2

A 50-year old woman (blood group A Rh positive, phenotype CcDEe Kk) with a euthyroid nodular goitre in menopause for 1 year was referred to us because of progressive weakness, ecchymoses and an episode of marked meno-metrorrhagia. Laboratory tests showed anaemia (Hb 9.5 g/dL), thrombocytopenia (platelets  $20 \times 10^9/L$ ) and indices of haemolysis (LDH 2,180 IU/L, total bilirubin 3.36 g/dL), five to six schistocytes per field in a peripheral blood smear and a negative Coombs' test compatible with the diagnosis of TTP. The patient had no neurological disorders or neuropsychological alterations.

The patient started treatment with PEX, in which her plasma was exchanged with 2,200 mL of fresh-frozen plasma/die (percentage of plasma volume exchanged: 100%) in ten sessions at the end of which she had a good recovery of her blood count and normalisation of indices of haemolysis. After the sixth session of plasmapheresis the patient



suddenly developed fever (39 °C), high levels of transaminases (ALT 224 IU/L) and a new decrease in platelet count, so she was started on treatment with rituximab 600 mg. After a few hours high levels of transaminases associated with a fever were again recorded levels and for this reason the treatment

was suspended. Only 6 days later was reactivation of a previous cytomegalovirus (CMV) infection clearly demonstrated (CMV IgM negative, CMV IgG positive, CMV pp65 positive, CMV DNA positive) and specific antiviral treatment was started (valaciclovir hydrochloride) (Figure 2).

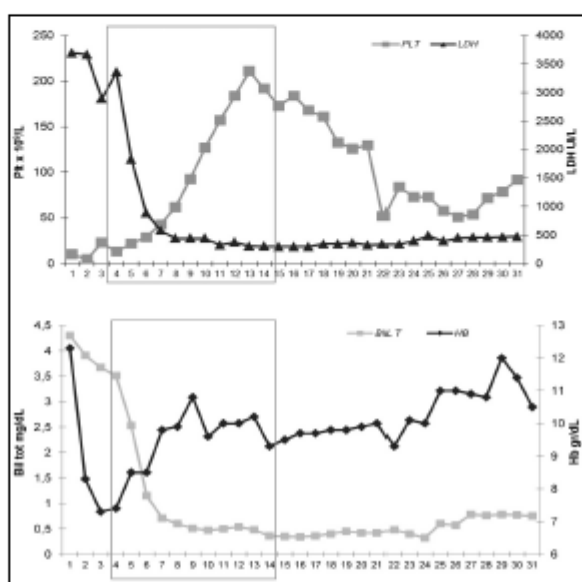

**Figure 1** - First relapse of TTP: trend in platelet count (Plt), haemoglobin concentration (Hb) and levels of total bilirubin (Bil Tot) and lactate dehydrogenase (LDH) during treatment with plasma exchange (box): the lack of a platelet response is clear.

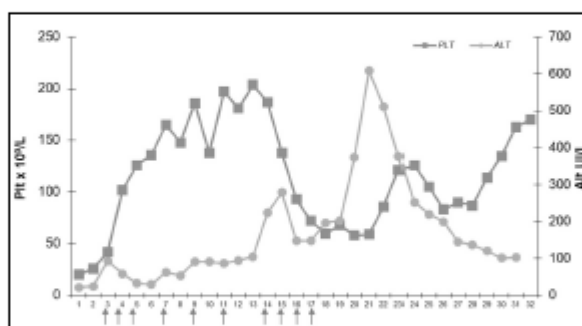

**Figure 2** - Trends in platelet count (Plt) and transaminase concentration (ALT) from the day of admission and in relation to the plasma exchange sessions (arrows) in a patient with cytomegalovirus infection.

**Case 3**

The third case was a 54-year old woman (blood group A Rh positive CcDEe kk) with an approximately 20-year history of Raynaud's phenomenon for which she is regularly treated in the Day Hospital with iloprost, a synthetic analogue of prostacyclin I with vasodilating, antioxidant and anti-aggregant activity. During the woman's last planned admission to the angiology ward, in which she should have received her treatment and follow-up, she was seen to have evident manifestations of cutaneous bleeding (petechiae on the lower limbs, ecchymoses in the gluteal region, haematuria) with clear laboratory evidence of anaemia (Hb 7.4 g/dL), thrombocytopenia (platelets  $23 \times 10^9/L$ ) and haemolysis (total bilirubin 1.39 g/dL; LDH 1,274 IU/L). There were six to seven schistocytes per field in the peripheral blood smear. The Coombs' test was negative. These findings were immediately compatible with a diagnosis of TTP, despite the absence of neurological disorders or neuropsychological disturbances, and PEX treatment was started with the aim of exchanging the patient's plasma with 2,000 mL of fresh-frozen plasma/die (percentage of plasma volume exchanged: 100%). At the end of the cycle of nine sessions, the patient had a good blood count recovery and complete resolution of haemolysis (Hb 11.1 g/dL; platelets  $183 \times 10^9/L$ ; LDH 279 IU/L) (Figure 3).

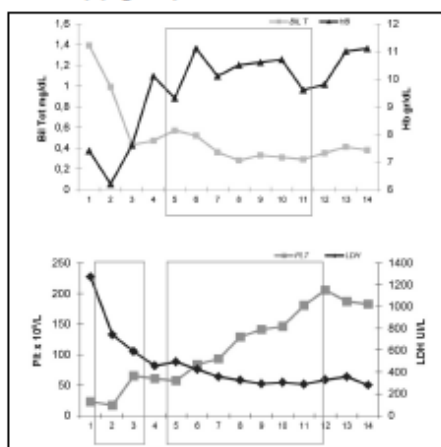
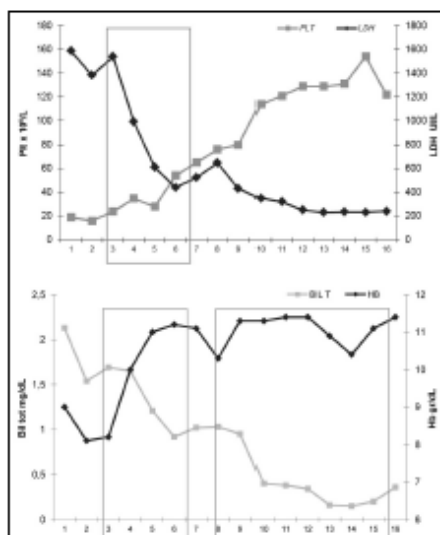

**Figure 3** - Trends in indices of haemolysis, thrombocytopenia and anaemia in a patient with Raynaud's phenomenon who responded to treatment with plasma exchange (sessions of plasma exchange carried out on the days shown in the box).

**Case 4**

A 31-year old pluripara (blood group A Rh positive with phenotype CcDEe kk) was referred to us because 1 month after her last delivery she developed notable weakness with even modest efforts often associated with recurrent paraesthesia of the upper limbs. At the time of her admission the clinical findings and laboratory results -anaemia (Hb 9 g/dL), thrombocytopenia (platelets  $28 \times 10^9/L$ ), signs of haemolysis (total bilirubin 2.13 g/dL; LDH 1,588 IU/L)- together with the presence of three to four schistocytes per field in a peripheral blood smear suggested a diagnosis of post-partum TTP. The patient was treated with 11 sessions of PEX in which her plasma was exchanged with 2,000 mL of fresh-frozen plasma/die (percentage of plasma volume exchanged: 100%); she was also given adjuvant cortisone therapy. During the first sessions of PEX the woman had an evident neurological disorder (dysarthria) which resolved completely as treatment was continued.

At the end of the treatment the patient had a clear recovery of platelet count (platelets  $154 \times 10^9/L$ ), an improvement of the picture of haemolysis (total bilirubin 0.30 g/dL; LDH 230 IU/L) and resolution of anaemia (Hb 11 g/dL) (Figure 4).



**Figure 4** - Trends in laboratory parameters in a patient with post-partum TTP who responded to treatment with plasma exchange.

## Discussion

The cases observed highlighted some particularly interesting clinical aspects. During a careful evaluation of the pharmacological history of case 1, it emerged that 2 months prior to the onset of the relapse, the patient had spontaneously assumed dietary supplements containing chitosan, a non-acetylated or partially deacetylated linear polysaccharide derived from chitin (which is found in nature in the exoskeleton of crustaceans, in the cuticle of insects and in the cell walls of fungi) associated with succinic acid<sup>16</sup>. Although a strong relationship between these molecules and the appearance of TTP has not been described in the literature, it is known that chitosan acts *in vitro* as a modulator of the activation and adhesion of platelets such that already a few years ago its haemostatic effect in heparinised mice was noted, confirming the fact that its activity does not depend on the interference with the coagulation cascade, but rather from an interaction with the elements of primary haemostasis<sup>17</sup>. Subsequent studies demonstrated that chitosan-dependent platelet activation causes the release of growth factors contained in the  $\alpha$ -granules of platelets and this stimulus could, therefore, be potentially useful for activating platelet-rich plasma, by-passing the allergic and prothrombotic effects of the thrombin normally used for this purpose<sup>18</sup>. In addition, a recent study indicated that succinate could also be an independent platelet activator<sup>19</sup>. It can, therefore, be hypothesised that, in the presence of a pathological condition predisposing to the formation of thrombi, a stimulus of this type could trigger relapse of the disease.

Case 2, in contrast, showed an interesting association between TTP and CMV infection. As recently observed<sup>20</sup> there may be relationship (albeit not well defined) between infections (including those by CMV) and TTP, particularly as regards response to therapy and the possibility of relapses or exacerbations. The mechanism of action of this is unclear but it is possible that infections together with other inflammatory stimuli could alter the delicate equilibrium between VWF and the activity of ADAMTS13. Infection-induced vascular activation could increase the release of ULVWF through the effects of interleukin-8 and tumour necrosis factor- $\alpha$ , while interleukin-6 inhibits the cleavage of ULVWF<sup>21</sup>; on the other hand, sepsis causes a decrease in the activity of ADAMTS13 both through its cleavage by proteolytic enzymes in the bloodstream and through

its reduced synthesis in the liver<sup>22</sup>. Furthermore, it is possible that, as for other micro-organisms, the immunogenic stimulation of the infection could cause a cross-reaction with anti-ADAMTS13 antibodies, reducing the activity of the protein and thereby limiting the response to therapy<sup>21,23</sup>. Furthermore, in the specific case of CMV, this virus can infect megakaryocytes directly and, therefore, reduce the production of platelets<sup>24</sup>. Indeed, we observed a proportional, inverse relationship between platelet count and transaminase levels in our patient (Figure 2).

As far as concerns case 3, Raynaud's phenomenon, the clinical expression of a transitory ischaemic crisis caused by vasoconstriction of the digital arteries, precapillary arterioles and cutaneous arteriovenous shunts in response to cold or emotion, can present as a primary condition or secondary to systemic sclerosis. The pathogenesis of this phenomenon, although not completely understood, may involve dysregulation of mechanisms of neuroendothelial control and the presence of intravascular anomalies such as platelet activation, reduced fibrinolysis, activation of white blood cells, reduced deformability of red blood cells, high oxidative stress due to accumulation of free radicals and the possible presence of anti-endothelin antibodies<sup>25</sup>. In particular, platelet activation plays a key role in the natural history of the disease. Indeed, during systemic sclerosis, the  $\alpha$ -granules of platelets release greater quantities of mediators with pleiotropic activities able to influence the natural history of the disease in various ways because they act on vascular tone and pro-inflammatory mechanisms as well as stimulating fibrogenesis and angiogenesis. In particular, high levels of vascular endothelial growth factor (VEGF) have been found in the serum of patients with systemic sclerosis. This growth factor, besides being involved in endothelial cell regeneration (stimulating their survival, growth, permeability and migration) is also involved in the regulation of inflammatory processes. The angiogenic activity and stabilisation of the vessel wall carried out by VEGF are expressed through interactions with other mediators present in the endothelium such as platelet-derived growth factor, transforming growth factor- $\beta$  and angiopoietin<sup>26</sup>. Between 1966 and 2010, 16 cases of systemic sclerosis associated with TTP were reported in the literature, one of which in a pregnant woman<sup>27-40</sup>; although the pathophysiological

mechanism underlying this association is not known, based on the foregoing, it can be hypothesised that the platelet activation present in systemic sclerosis could be a valid substrate for exposing a latent thrombotic state related to a functional or quantitative lack of ADAMTS13; furthermore, the presence of IgG autoantibodies against ADAMTS13<sup>14</sup> is indicative of a relationship with autoimmune diseases, of which systemic sclerosis is one.

The last case observed (case 4) focused our attention on the association between TTP and pregnancy. The incidence of pregnancy-associated TTP is 1:25,000 pregnancies and this form of TTP accounts for about 10% of all cases of TTP. The disease can appear *de novo* during the pregnancy or as a reactivation of a previously known TTP triggered by the pregnancy because of the presence of placental proteins in the bloodstream capable of inducing the production of anti-ADAMTS13 antibodies<sup>41</sup>. Unfortunately, these clinical pictures often overlap with pre-eclampsia/eclampsia and HELLP and so the diagnosis is missed. From a careful review of published data on pregnancy-associated TTP (from which cases of pre-eclampsia/eclampsia and HELLP were excluded) from 1955 to 2006, Martin *et al.* showed that the mean gestational age of onset of TTP is late: among the patients affected by ante-partum TTP, 55.5% developed the disorder in the second trimester of pregnancy (28.9±8.3 weeks), 32.8% during the third trimester (38.5±1.9 weeks) and only 11.7% in the first trimester. TTP in the puerperium is

less common (12.7%) and occurs a mean of 4 days after delivery, although the range is from 0 to 42 days. However, there are no significant differences in the outcome of patients who develop TTP ante-partum or post-partum with regards to either laboratory findings or maternal mortality (ante-partum 25.8%, post-partum 23.8%)<sup>42</sup> and in both cases PEX (better if associated with adjuvant cortisone therapy) is the treatment of choice (Figure 4).

The type of response in the days immediately following suspension of PEX can be evaluated in the light of the cases observed. Patients with a first episode of disease are defined "responders" if they achieve normalisation of platelet count ( $\geq 150 \times 10^9/L$ ) and LDH ( $\leq 300$  IU/L), an increase in haemoglobin ( $\geq 9.5$  g/dL) and clinical resolution of neurological symptoms (when present) and signs of microangiopathy (ecchymoses, petechiae, haematomas) 3 days after the last treatment; as "partial responders" if they have a clear improvement in clinical and laboratory findings but a platelet count between  $75 \times 10^9/L$  and  $150 \times 10^9/L$ ; and as "non-responders or refractory" if the platelet count remains  $\leq 75 \times 10^9/L$  with or without neurological disturbances and/or persistence of signs of microangiopathic damage. The patient with a relapse of TTP was evaluated using the same criteria but extending the time of observation to 8 days after the last treatment in order to assess whether a relapse occurred after suspension of treatment (Figures 5 and 6).

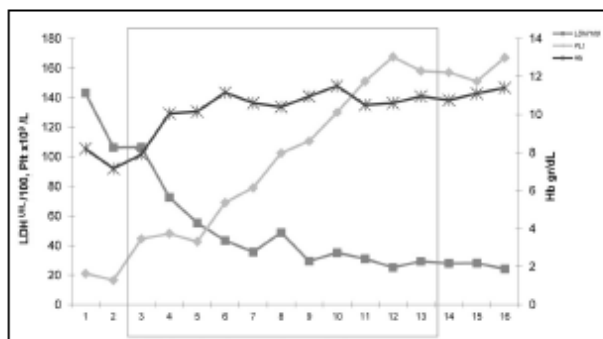

Figure 5 - Mean trends in laboratory parameters - mean platelet count (Plt), mean lactate dehydrogenase concentration (LDH) and mean haemoglobin concentration (Hb) - in patients responding to treatment (plasma exchange sessions in the box).



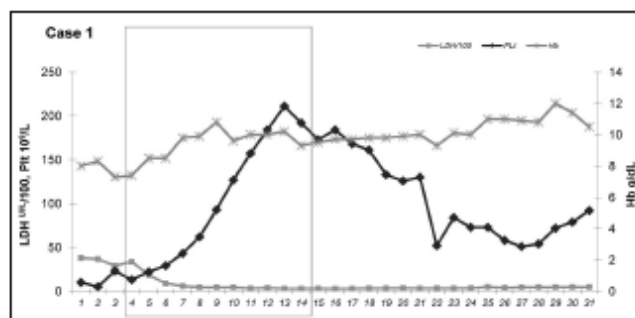

**Figure 6** - Mean trends in laboratory parameters - mean platelet count (Plt), mean lactate dehydrogenase concentration (LDH) and mean haemoglobin concentration (Hb) - in patients not responding to treatment (plasma exchange sessions in the box). There is a clear drop in platelet count immediately after suspension of the treatment.

In only two patients (cases 1 and 2) thrombocytopenia returned brusquely, after significant increases in platelet counts (reaching values  $\geq 200 \times 10^9/L$ ) during PEX treatment, such that the counts fell again to values considerably below those established as the cut-off for defining non-responders.

As mentioned, the underlying causes of these decreases in platelet count differed in the two patients. In case 1, after the first 7 days in which the platelet count was stable, the count began to decrease rapidly probably due to an early relapse of the disease. During

this period the patient started treatment with rituximab (on day 26) which produced a slow recovery of the platelet count and level of haemoglobin (Figure 7). In contrast, case 2 showed an abrupt drop in circulating platelet count already during the last sessions of PEX contemporaneously with a brusque, fast rise in ALT due to CMV-associated hepatitis (Figure 2). In reality, this patient, rather than being a true non-responder, should be considered to have had a complicated form of TTP in which the normalisation of the platelet count occurred not only in response to



**Figure 7** - Trends in platelet count (Plt), lactate dehydrogenase concentration (LDH) and haemoglobin concentration (Hb) in a patient with a relapse of TTP not responding to treatment (plasma exchange sessions in the box) (case 1). There is clear drop in the platelet count a few days after suspension of treatment and a persistently low count until the patient's discharge from hospital.

the administration of rituximab (on day 17) but also because of the subsequent introduction of antiviral therapy (valaciclovir hydrochloride administered on day 23) (Figure 8).

The possibility of classifying the patients' outcome as a complete response or relapse will depend on their clinical wellbeing and laboratory results in a follow-up lasting at least 12 months.

One further consideration should be made concerning the patients' blood groups. In recent studies on the correlation between TTP and blood group<sup>43</sup> it has been seen that group O patients are underrepresented among patients with TTP, leading to the hypothesis that such individuals are partially protected against the development of TTP. This hypothesis is based on various observations made during comparisons of O group and non-O group individuals: subjects with blood group O have lower levels of VWF, faster clearance of VWF, faster proteolysis of VWF by ADAMTS13 and an inverse relationship between levels of plasma activity of ADAMTS13 and VWF. All these factors make group O subjects better protected against the development of TTP because they have less VWF available (the key protein in the aetiopathogenesis of TTP) and what is present is broken down more quickly. This protection from TTP is in line with previous observations that group O individuals have a degree of protection from myocardial, cerebral and peripheral vascular thrombosis<sup>44</sup>.

Terrel *et al.*<sup>45</sup>, who studied a larger cohort of patients (281 cases of TTP from 1995 to 2009 recruited through the Oklahoma TTP Registry) relating blood group with circulating ADAMTS13 levels, showed that in actual fact when there was a severe deficiency of ADAMTS 13, the frequency of blood group O was significantly higher than expected, whereas when the reduction of ADAMTS 13 was not severe, the frequency of group O individuals was lower than that of subjects with non-O groups (as previously found). The blood group characteristics are, therefore, probably only significant if ADAMTS13 function is not severely compromised.

The series of patients we studied was very small and did not allow us to make hypotheses on statistically significant correlations with the ABO system since quantitative, qualitative and genetic assays of the ADAMTS 13 profile were not conducted. However, we note that 75% of our patients had a non-O blood group and the only patient with group O was treated for TTP in relapse, an indicator of greater aggressiveness of the disease. This observation is in line with the previous considerations.

## Conclusions

TTP, which is characterised by thrombocytopenia and microangiopathic haemolytic anaemia, was a fatal condition until the introduction, in 1970, of PEX, a treatment which has radically changed the natural history of this disease, reducing the mortality from

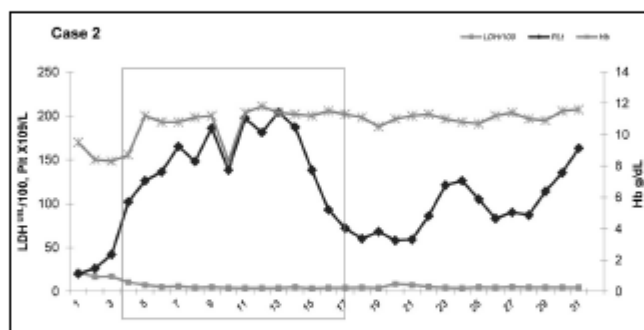

**Figure 8** - Trends in platelet count (Pit), lactate dehydrogenase concentration (LDH) and haemoglobin concentration (Hb) in a patient with cytomegalovirus-associated hepatitis and TTP not responding to treatment (plasma exchange sessions in the box) (case 2). The platelet count fell during treatment and returned to optimal levels after successful antiviral therapy.

more than 90% to about 10-20%<sup>13</sup>. The mainstay of the treatment of acute TTP is daily PEX, exchanging the patient's plasma with fresh-frozen plasma or plasma lacking cryoprecipitate, which should be started within 24-48 hours of the appearance of the disease because it has been shown that a delay in initiation of therapy could be one of the factors responsible for treatment failure<sup>4</sup>. The duration of treatment required to obtain a remission varies greatly: the mean number of sessions necessary is about nine, since premature suspension or a single session of PEX can be associated with an exacerbation of the disease<sup>4</sup>. Furthermore, it is empirically recommended that exchange treatment is continued for at least 2 days after the achievement of complete remission, in accordance with guidelines that call for treatment continuation until platelet counts reach values  $\geq 150 \times 10^9/L$  and the levels of LDH return to within the normal range for 2-3 consecutive days. However, LDH, which is rapidly removed during PEX, does not reflect the response to treatment and even the possible persistence of some schistocytes in the peripheral blood smear, in the absence of other clinical and laboratory features, is not a contraindication to treatment suspension<sup>4</sup>. The guidelines of the American Society of Apheresis propose daily PEX treatment in TTP with a grade 1A recommendation (*strong recommendation, high-quality evidence*)<sup>15</sup>.

The value of plasma therapy was already demonstrated some years ago in a prospective, randomised trial comparing PEX and plasma infusions in the treatment of adults with TTP<sup>46</sup>: the 6-month survival rate was 78% in the group treated with PEX and 63% in that given plasma infusions, with this difference in favour of PEX being statistically significant ( $p=0.036$ ). Nowadays the standard treatment for TTP is PEX with fresh-frozen plasma at a dose of 40 to 60 mL/Kg daily, started within 24 hours of the diagnosis of the disease and continued for at least 2 days after the complete remission in which the patient achieves a normal platelet count and LDH level in the absence of neurological symptoms. Only in the case that PEX cannot be performed is treatment with plasma infusions indicated: the dose of the fresh-frozen plasma infusion is at least 30 mL/Kg daily<sup>4</sup>. In secondary forms, patients who are refractory to PEX and relapse are candidates for second-level therapy with splenectomy, vincristine, azathioprine

and also rational use of immunosuppressant drugs (corticosteroids, cyclophosphamide and cyclosporine) but above all with rituximab, a monoclonal chimeric antibody directed against CD20 (expressed on the surface of B lymphocytes), which rapidly depletes blood, lymph nodes and bone marrow of B cells. The rationale for using this drug in the treatment of TTP is its capacity to destroy the CD20+ B lymphocytes which produce anti-ADAMTS13 antibodies even if, in autoimmune diseases, the mechanism of action is not limited to depletion of B cells, as demonstrated by recent clinical studies in which the levels of autoantibodies were not significantly reduced during the treatment. In addition to the direct effect of the drug on B lymphocytes (depletion and consequent reduced function of cells presenting the antigen, release of inflammatory and immunomodulatory cytokines and co-stimulation signals), it has been proposed that the bond between rituximab and opsonised B cells blocks the function of the Fc receptor of macrophages. This block is able to reduce the splenic sequestration of platelets in TTP<sup>13,47,48</sup>.

More recently another drug, defibrotide, has acquired growing importance. This single-stranded polydeoxyribonucleotide derived from porcine mucosa (by controlled depolymerisation) has potent antithrombotic, anti-ischaemic and anti-inflammatory effects with thrombolytic properties without systemic anticoagulant effects. Defibrotide interacts with the receptor for adenosine and leads to the selective release of prostaglandins I<sub>2</sub> and E<sub>2</sub> with consequent inhibition of platelet function and activation, reduces the activity of plasminogen activator inhibitor-1 and potentiates the function of tissue plasminogen activator<sup>49,50</sup>.

Patients with idiopathic TTP generally respond better to treatment with PEX than do patients with secondary TTP.

**Keywords:** thrombotic thrombocytopenic purpura, ADAMTS 13, plasma exchange therapy.

#### Acknowledgments

Claudia Rizzo is PhD student at the Molecular Medicine PhD course (directed by Calogero Caruso) at Palermo University and this work is submitted in partial fulfillment of the requirement for her PhD degree.



The Authors declare no conflicts of interest.

## References

- 1) Ruggenenti P, Remuzzi G. The pathophysiology and management of thrombotic thrombocytopenic purpura. *Eur J Haematol* 1996; **56**: 191-7.
- 2) Frawley N, Ng AP, Nicholls K, et al. Thrombotic thrombocytopenic purpura is associated with a high relapse rate after plasma exchange: a single-centre experience. *Intern Med J* 2009; **39**: 19-24.
- 3) Mannucci PM, Peyvandi F. TTP and ADAMTS13: when is testing appropriate? *Hematology Am Soc Hematol Educ Program* 2007: 121-6.
- 4) Allford SL, Hunt BJ, Rose P, et al. Guidelines on the diagnosis and management of the thrombotic microangiopathic haemolytic anaemias. *Br J Haematol* 2003; **120**: 556-73.
- 5) Moake JL, Rudy CK, Troll JH, et al. Unusually large plasma factor VIII: von Willebrand factor multimers in chronic relapsing thrombotic thrombocytopenic purpura. *N Engl J Med* 1982; **307**: 1432-5.
- 6) Tsai H-M. Physiologic cleavage of von Willebrand factor by a plasma protease is dependent on its conformation and requires calcium ion. *Blood* 1996; **87**: 4235-44.
- 7) Furlan M, Robles R, Lammle B. Partial purification and characterization of a protease from human plasma cleaving von Willebrand factor to fragments produced in vivo proteolysis. *Blood* 1996; **87**: 4223-34.
- 8) Levy GG, Nichols WC, Lian EC, et al. Mutations in a member of the ADAMTS gene family cause thrombotic thrombocytopenic purpura. *Nature* 2001; **413**: 488-94.
- 9) Zheng X, Chung D, Takayama TK, et al. Structure of von Willebrand factor-cleaving protease (ADAMTS13), a metalloprotease involved in thrombotic thrombocytopenic purpura. *J Biol Chem* 2001; **276**: 41059-63.
- 10) Levy GG, Nichols WC, Lian EC, et al. Mutations in a member of the ADAMTS gene family cause thrombotic thrombocytopenic purpura. *Nature* 2001; **413**: 488-94.
- 11) Shelat SG, Ai J, Zheng XL. Molecular biology of ADAMTS13 and diagnostic utility of ADAMTS13 proteolytic activity and inhibitor assays. *Semin Thromb Hemost* 2005; **31**: 659-72.
- 12) Hovinga JA, Vesely SK, Terrell DR, et al. Survival and relapse in patients with thrombotic thrombocytopenic purpura. *Blood* 2010; **115**: 1475-6.
- 13) Barcellini W, Zanella A. Rituximab therapy for autoimmune haematological diseases. *Eur J Intern Med* 2011; **22**: 220-9.
- 14) Ferrari S, Muddle GC, Rieger M, et al. IgG subclass distribution of anti-ADAMTS13 antibodies in patients with acquired thrombotic thrombocytopenic purpura. *J Thromb Haemost* 2009; **7**: 1703-10.
- 15) Szczepiorowski Z, Winters J, Bandarenko N, et al. Guidelines on the use of therapeutic apheresis in clinical practice - evidence-based approach from the Apheresis Applications Committee of the American Society for Apheresis. *J Clin Apheresis* 2010; **25**: 83-177.
- 16) Lord MS, Cheng B, McCarthy SJ, et al. The modulation of platelet adhesion and activation by chitosan through plasma and extracellular matrix proteins. *Biomaterials* 2011; **32**: 6655-62.
- 17) Chou TC, Fu E, Wu CJ, Yeh JH. Chitosan enhances platelet adhesion and aggregation. *Biochem Biophys Res Commun* 2003; **302**: 480-3.
- 18) Shen EC, Chou TC, Gau CH, et al. Releasing growth factors from activated human platelets after chitosan stimulation: a possible bio-material for platelet-rich plasma preparation. *Clin Oral Implants Res* 2006; **17**: 572-8.
- 19) Högborg C, Gidlöf O, Tan C, et al. Succinate independently stimulates full platelet activation via cAMP and phosphoinositide 3-kinase- $\beta$  signaling. *J Thromb Haemost* 2011; **9**: 361-72.
- 20) Cserti CM, Landaw S, Uhl L. Do infections provoke exacerbations and relapses of thrombotic thrombocytopenic purpura? *J Clin Apher* 2007; **22**: 21-5.
- 21) Bar Meir E, Amital H, Levy Y, et al. Mycoplasma pneumoniae-induced thrombotic thrombocytopenic purpura. *Acta Haematol* 2000; **103**: 112-5.
- 22) Ono T, Minuro J, Madoiwa S, et al. Severe secondary deficiency of von Willebrand factor-cleaving protease (ADAMTS13) in patients with sepsis-induced disseminated intravascular coagulation: its correlation with development of renal failure. *Blood* 2006; **107**: 528-34.
- 23) Niv E, Segev A, Ellis MH. Staphylococcus aureus bacteremia as a cause of early relapse of thrombotic thrombocytopenic purpura. *Transfusion* 2000; **40**: 1067-70.
- 24) DiMaggio D, Anderson A, Bussel JB. Cytomegalovirus can make immune thrombotic purpura refractory. *Br J Haematol* 2009; **146**: 104-12.
- 25) Herrick AL. Pathogenesis of Raynaud's phenomenon. *Rheumatology* 2005; **44**: 587-96.
- 26) Solamilla A, Villeneuve J, Auguste P, et al. The transport of high amounts of vascular endothelial growth factor by blood platelets underlines their potential contribution in systemic sclerosis angiogenesis. *Rheumatology* 2009; **48**: 1036-44.
- 27) Watanabe R, Shirai T, Tajima Y, et al. Pregnancy-associated thrombotic thrombocytopenic purpura with anti-centromere antibody-positive Raynaud's syndrome. *Intern Med* 2010; **49**: 1229-32.
- 28) Manadan AM, Harris C, Block JA. Thrombotic thrombocytopenic purpura in the setting of systemic sclerosis. *Semin Arthritis Rheum* 2005; **34**: 683-8.
- 29) Kapur A, Ballou SP, Renston JP, et al. Recurrent acute scleroderma renal crisis complicated by thrombotic thrombocytopenic purpura. *J Rheumatol* 1997; **24**: 2469-72.
- 30) Barton JC, Saway DA, Blackburn WD, et al. Thrombotic thrombocytopenic purpura in systemic sclerosis. *J Rheumatol* 1989; **16**: 1400-1.
- 31) Towheed TE, Anastassiades TP, Ford SE, et al. Thrombotic thrombocytopenic purpura as an initial presentation of limited systemic sclerosis. *J Rheumatol* 1999; **26**: 1613-6.



- 32) Badesha PS, Bhardwaj A. Thrombotic thrombocytopenic purpura in a patient with diffuse scleroderma. *J Assoc Physicians India* 1996; **44**: 274-5.
- 33) Ricker DM, Sharma HM, Nahman NS Jr. Acute renal failure with glomerular thrombosis in a patient with chronic scleroderma. *Am J Kidney Dis* 1989; **14**: 524-6.
- 34) Miller A, Ryan PF, Dowling JP. Vasculitis and thrombotic thrombocytopenic purpura in a patient with limited scleroderma. *J Rheumatol* 1997; **24**: 598-600.
- 35) Cookson S, Krueger ML, Bennett RM. Fulminant thrombotic thrombocytopenic purpura in a patient with the limited form of scleroderma: successful outcome using plasma exchange. *J Rheumatol* 1991; **18**: 900-1.
- 36) Bhardwaj A, Badesha PS. Seizures in a patient with diffuse scleroderma. *Postgrad Med J* 1995; **71**: 687-9.
- 37) Kfoury Baz EM, Mahfouz RA, Masri AF, Jamaledine GW. Thrombotic thrombocytopenic purpura in a case of scleroderma renal crisis treated with twice-daily therapeutic plasma exchange. *Ren Fail* 2001; **23**: 737-42.
- 38) Karim M, Vaux E, Davies DR, Mason PD. Renal failure due to scleroderma with thrombotic microangiopathy developing in a woman treated with carboplatin for ovarian cancer. *Clin Nephrol* 2002; **58**: 384-8.
- 39) Yusin J, Lewin K, Clements P. Thrombotic thrombocytopenia purpura in a patient with systemic sclerosis. *J Clin Rheumatol* 2001; **7**: 106-11.
- 40) Mimori A, Nara H, Kaneko N, et al. Three patients with systemic sclerosis complicated by microangiopathic haemolytic anemia and thrombocytopenia. *Nihon Rinsho Meneki Gakkai Kaishi* 2000; **23**: 57-63.
- 41) Gerth J, Schleussner E, Kentouche K, et al. Pregnancy-associated thrombotic thrombocytopenic purpura. *Thromb Haemost.* 2009; **101**: 248-51.
- 42) Martin JN, Bailey AP, Rehberg JF, et al. Thrombotic thrombocytopenic purpura in 166 pregnancies: 1955-2006. *Am J Obstet Gynecol* 2008; **199**: 98-104.
- 43) Staropoli JF, Stowell CP, Tuncer HH, Marques MB. An inquiry into the relationship between ABO blood group and thrombotic thrombocytopenic purpura. *Vox Sang* 2009; **96**: 344-8.
- 44) Zuberi L, Yerasure D, Kuriakose P. Effect of blood group on idiopathic thrombotic thrombocytopenic purpura. *J Clin Apher* 2009; **24**: 131-3.
- 45) Terrell DR, Motto DG, Kremer Hovinga JA, et al. Blood group O and black race are independent risk factors for thrombotic thrombocytopenic purpura associated with severe ADAMTS13 deficiency. *Transfusion* 2011; **51**: 2237-43.
- 46) Rock GA, Shumak KH, Buskard NA, et al. Comparison of plasma exchange with plasma infusion in the treatment of thrombotic thrombocytopenic purpura: Canadian Apheresis Study Group. *N Engl J Med* 1991; **325**: 393-7.
- 47) Taylor RP, Lindorfer MA. Drug insight: the mechanism of action of rituximab in autoimmune disease - the immune complex decoy hypothesis. *Nat Clin Pract Rheumatol* 2007; **3**: 86-95.
- 48) Stasi R, Stipa E, Forte V, et al. Variable patterns of response to rituximab treatment in adults with chronic idiopathic thrombocytopenic purpura. *Blood* 2002; **99**: 3872-3.
- 49) Stavrou E, Lazarus HM. Thrombotic microangiopathy in haematopoietic cell transplantation: an update. *Mediterr J Hematol Infect Dis* 2010; **2**: e2010033.
- 50) Corti P, Uderzo C, Tagliabue A, et al. Defibrotide as a promising treatment for thrombotic thrombocytopenic purpura in patients undergoing bone marrow transplantation. *Bone Marrow Transplant* 2002; **29**: 542-3.

Received: 4 October 2011 - Revision accepted: 5 December 2011

**Correspondence:** Calogero Caruso  
Pathobiology and Forensic and Medical Biotechnologies  
University of Palermo  
Corso Tukory 211  
96100 Palermo, Italy  
e-mail: calogero.caruso@unipa.it

## **4. The role of platelet gel in osteoarticular injuries of young and old patients**

RESEARCH

Open Access

## The role of platelet gel in osteoarticular injuries of young and old patients

Claudia Rizzo<sup>1,2\*</sup>, Roberta Vetro<sup>3</sup>, Angelo Vetro<sup>3</sup>, Roberto Mantia<sup>3</sup>, Angelo Iovane<sup>4</sup>, Marco Di Gesu<sup>3</sup>, Sonya Vasto<sup>5,6</sup>, Laura Di Noto<sup>1,2</sup>, Giuseppina Mazzola<sup>1</sup> and Calogero Caruso<sup>1,2</sup>

### Abstract

**Background:** The use of autologous platelet gel in orthopedics is effective in accelerating the healing process of osteochondral, muscle, tendon and ligament lesions. The aim of our study was to verify whether the variability in response to infiltration with platelet gel was dependent on the underlying disease treated, sex and age of the patients. During four years, 140 patients have been treated for musculoskeletal injuries by infiltration of gel platelet and lysate platelet obtained from autologous thrombin, with echo-ultrasound guided. The response to treatment was assessed at different time points T0, T1, T2 with respect to pain estimation (VAS), joint mobility (ROM scale) and echo-ultrasound evaluation. This data collection has allowed classifying the response to treated lesions in three categories: NR (no response), PR (partial response), CR (complete response).

**Results:** The data here reported showed that the ability to physical recovery response is evident in tendon injuries, while the large joints injuries gave a poor response. Almost all patients showed a significant pain relief after the first infiltration, but in terms of echo-ultrasound evaluation and tissue repair, only the muscle and tendon injuries showed hyperechoic areas, signs or evidences of repair. Concerning the correlation between response to infiltration with platelet gel and gender/age of the patients, the clinical results appear not influenced by the age and the gender of the patient.

**Discussion:** Our data indicate that, pain relief and ability to physical recovery of muscles, tendons and ligaments depend on tissue repair clearly visible by echo ultrasound evaluation. On the other hand tissue repair seems not occur in the large joints (hip and knee) where arthritis and /or corrosion of articular cartilage cannot be repaired and the only relief is exclusively linked to the reduction of periarticular inflammation (reduction of the inflammatory leakage and signs).

**Keywords:** Ageing, Inflammation, Osteoarticular injuries, Osteoarthritis, Regenerative medicine

### Background

The idea of using blood products for not strictly transfusional purposes dates back to the early 70s, when for the first time, fibrin glue was produced and used to accelerate tissue repair during surgery. In the 80s, for the first time, David Knighton developed a technique of *in vitro* stimulation of platelets by thrombin solutions, which allowed the collection of a rich growth factors supernatant, that suitably purified, was applied topically under

the form of gel. It was clear that this gel formulation was able to stimulate the repair of skin ulcers and triggered and accelerated the processes of tissue regeneration. The paramount role of platelets as agents of tissue regeneration, has suggested this application in a variety of clinical settings and for aesthetic purpose [1].

Platelet are not only the protagonists of the haemostatic process, but plays also a key role in the inflammatory process (due to high concentrations of pro-inflammatory and immune-modulatory cytokines), in the antimicrobial defence (since the  $\alpha$ -granules are rich in "protein microbicide platelet", chemokines -CXCL4, thymosin- $\beta$ 4, derivatives of CXCL7- PBP, CTAP - III, NAP- 2 and CCL5 -6 and complement proteins), in cell replication (mitogenesis), in angiogenesis and, last but

\* Correspondence: claudia.rizzo@unipa.it  
<sup>1</sup>Unit of Transfusion Medicine, University Hospital "Paolo Giaccone", Palermo, Italy  
<sup>2</sup>Department of Pathobiology and Medical and Forensic Biotechnologies, University of Palermo, Palermo, Italy  
Full list of author information is available at the end of the article



© 2014 Rizzo et al.; licensee BioMed Central Ltd. This is an Open Access article distributed under the terms of the Creative Commons Attribution License (<http://creativecommons.org/licenses/by/4.0/>), which permits unrestricted use, distribution, and reproduction in any medium, provided the original work is properly credited. The Creative Commons Public Domain Dedication waiver (<http://creativecommons.org/publicdomain/zero/1.0/>) applies to the data made available in this article, unless otherwise stated.

not least, actively modulate tissue regeneration. These activities are possible because platelet precursors, megakaryocytes, actively produce growth factors (VEGF, PDGF, FGF, EGF, HGF, IGF) responsible for endothelial and fibroblasts cells permeability, recruitment and proliferation [2-6].

Thus the use of autologous platelet gel in orthopaedics could be an effective therapy in accelerating the healing process not only for bone and osteochondral lesions, but also for muscle, tendons and joints diseases. Currently, the literature data are conflicting regarding the efficacy of this treatment. Several studies show that in reconstructive orthopaedic surgery, the application of platelet gel combined with the bone matrix apposition, confirmed the ability of platelet growth factors to determine bone regeneration, and provide the regenerative stimulus to autologous bone used as a filler and source of osteoblasts [7-9].

In addition, the application of platelet gel in the treatment of traumatic tendon lesions showed significant feedback not only for the tissue regenerative activity, but also for anti-inflammatory and analgesic effect [10,11]. Moreover several data showed platelet gel used as a therapeutic choice in the treatment of epicondylitis, of plantar fasciitis and Achilles tendon injuries with healing delayed. This treatment has been also used in inflammatory hip disease, in chondropathies of the knee, in ankle, in hallux rigidus and in acute and chronic muscle injury treatment [12-15].

However, despite the favourable results obtained in several case series, results from randomized clinical trials are controversial [16-19].

So, the aim of our study was to verify whether the variability in response to infiltration with platelet gel was dependent on the underlying disease treated and sex and age of the patients. Therefore, we selected a group of patients (divided by sex, age and osteoarticular lesions)

that have not been treated surgically or with other infiltrating application on the site of injury and we proposed to all the same standard-protocol for the production of platelet gel. We excluded patients with systemic diseases involving osteoarticular system (i.e. autoimmune diseases).

## Results

From a first glance of the sample population, the pathologies mostly treated with platelet gel are injuries of the supraspinatus tendon, the gonarthrosis and injuries of the Achilles tendon (Figure 1). There are differences in diseases distribution especially concerning gender: the female population seems more affected by lesions of the large joints (coxarthrosis and gonarthrosis) and the supraspinatus tendon while other clinical conditions seems to affect more the male population (Figure 2).

The stratification for age (mean of age 58 years old) showed that arthritic conditions (gonarthrosis, osteoarthritis, shoulder arthritis) and large joints condition (supraspinatus tendon injury) affect a population little older (mean age 60 years), while the ligament and tendon injuries are more frequent in younger subjects (mean age 47 years). When divided by gender and onset of the injury, the female population is often treated for disorders of the knee in middle age with respect to male (68 years females, 58 males), while the tendon and muscle injuries affect male population frequently at younger age (46 years old males, 51 females) (Figure 3).

Regarding the clinical results, all treated cases in our study, except those with osteoarthritis, (Figure 4) have shown a significant reduction in pain after the first infiltration. These observations appear not influenced by the age and the gender of the patient.

Evidence was achieved only in the study sample with at least 10 treated patients (Table 1), so it hasn't been achieved a good standardized assessment on the inability

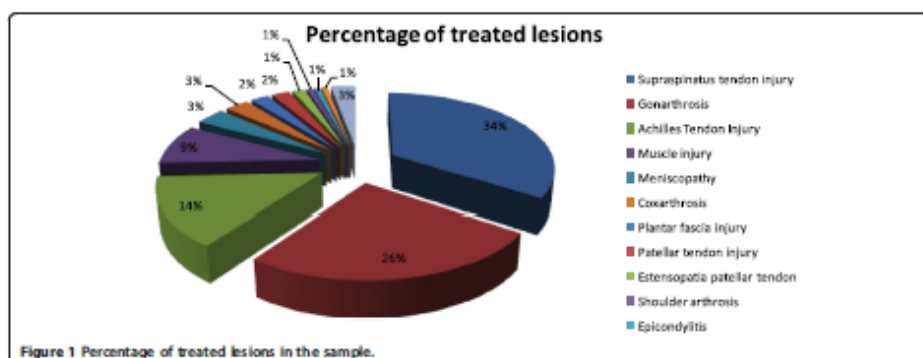

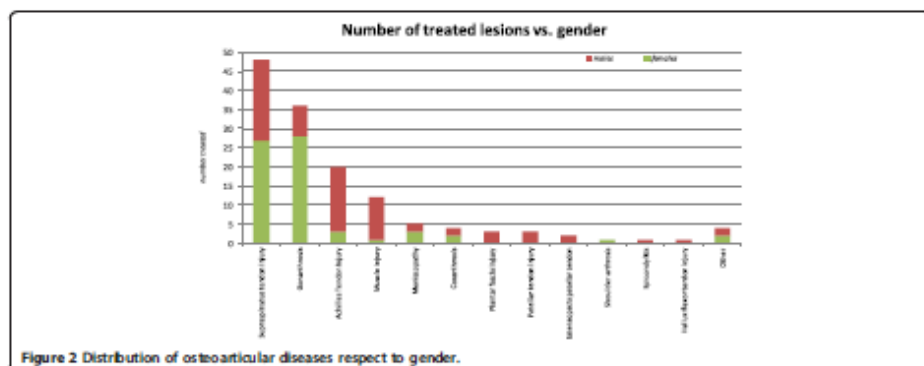

Figure 2 Distribution of osteoarticular diseases respect to gender.

to perform physical task on the other few patients treated.

However, the data showed complete ability response and fully restoration of joint ability (score 3) in a large part of patients treated for tendon injuries. The treatment of large joints to cure arthritis, instead, gave a poor response in terms of recovery abilities and even almost 10% of the observed gonarthrosis did not show any significant result compared to the early status (score 1) (Figure 5).

It seems that the success of the treatment (score 2 and score 3) is age independent; only in one case in which the treatment did not gain any effect (score 1) the older age might have been associated to the result (Figure 6).

In addition, the study of the response in relation to the degree of injury (tendinopathy, tendinopathy, chronic partial rupture, sub-total rupture, total rupture) shows that the treatment is independent on the initial lesion (Figure 7).

On the basis of the clinical evaluation after the first infiltration, the patients were given the indication to further infiltration according to time schedule and to the pathology (Figure 8).

On average, 102 patients (73% of the population sample) were infiltrated with the second aliquot after a month and a half (48 days) and the third infiltration was performed to 61 patients (44% of the population sample) around five months after the second (158 days). The frequency with which are carried out infiltration is strictly related to the type of lesion: the injuries of tendons and muscles are infiltrated at earlier time schedule than those involving large joints (Figure 9).

The most representative example of tissue repair and recovery ability restoration, is represented by the injury of the Achilles tendon in which after two months of treatment (T2) a complete tissue repair occurred.

Another model of tissue repair is the supraspinatus tendon and muscle injuries: at T1 is already possible to

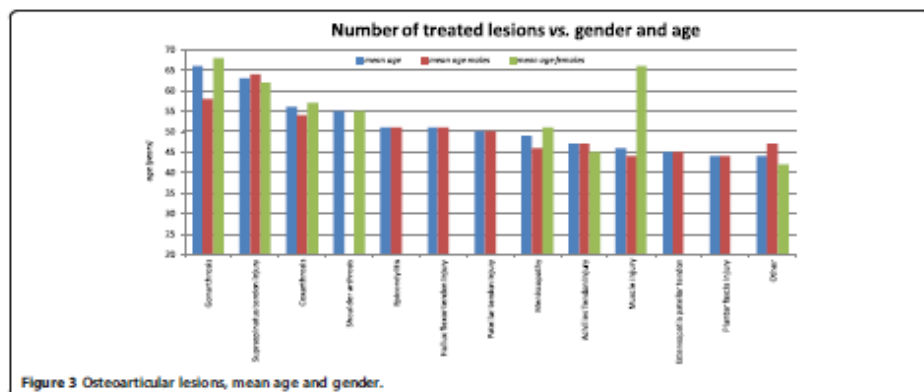
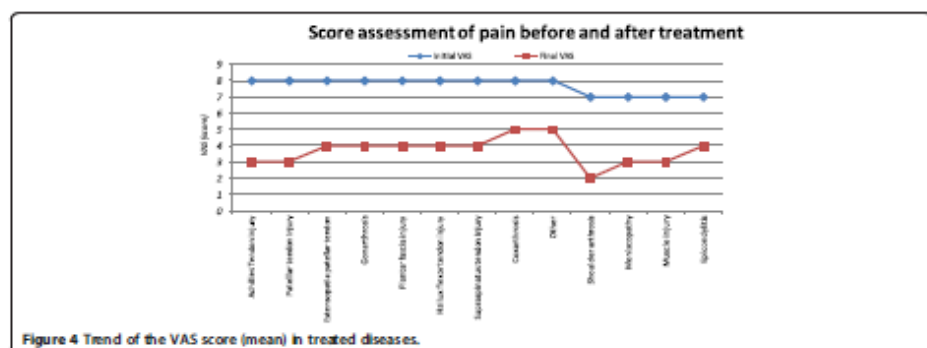

Figure 3 Osteoarticular lesions, mean age and gender.



assess the repair of areas with increase of hyperechoic signals.

The lower clinical response is represented by the treatment of osteoarthritis of the large joints (coxarthrosis and gonarthrosis) where comparing echo ultrasound at T0 and T2. The only sign is referred to the

reduction of the inflammatory area and inflammatory leakage but without any sign of cartilage repair.

The infiltration of the cartilage lesion of the knee, such as the lesion of the patellar tendon, instead, showed by diagnostic imaging clear evidence of tissue repair.

**Table 1** Study sample with details of the treated diseases and degree of injury

Treated lesions	Patients no.	No. according to gender (mean age)		Degree of injury	
		Male	Female		
Supraspinatus tendon injury	49	21 (54)	28 (52)	Tendinopathy	22%
				Chronic tendinopathy	24%
				partial rupture	31%
				Sub-total rupture	6%
				Total rupture	16%
Gonarthrosis	37	9 (58)	28 (58)		
Achilles tendon injury	20	17 (47)	3 (45)	Tendinopathy	40%
				Chronic tendinopathy	10%
				Partial rupture	40%
				Sub-total rupture	
				Total rupture	10%
Muscle injury	12	11 (44)	1 (56)	Distraction muscle	42%
				Muscle tear	8%
				Focal muscle tear	50%
Meniscopathy	5	2 (49)	3 (51)		
Coxarthrosis	3	1 (54)	2 (57)		
Plantar fascia injury	3	3 (44)			
Patellar tendon injury	3	3 (50)			
Estenopatia patellar tendon	2	2 (45)			
Shoulder arthritis	1	1 (55)			
Epicondylitis	1	1 (51)			
Hallux flexor tendon injury	1	1 (51)			
Other	4	2 (47)	2 (42)		



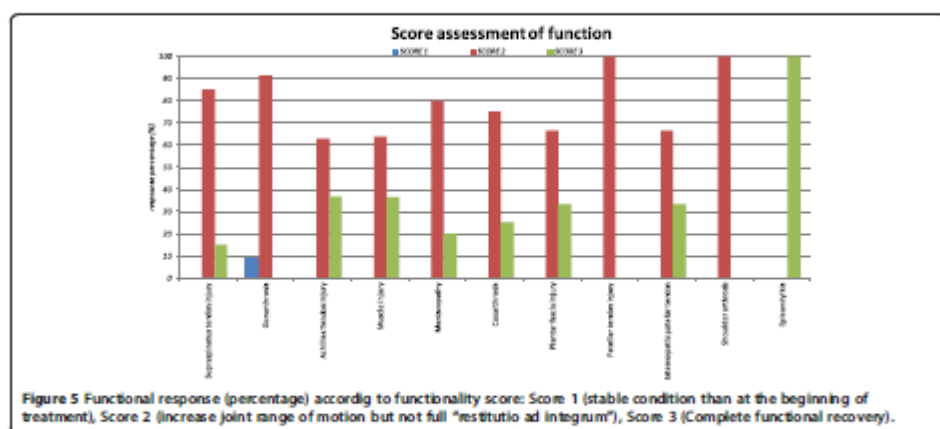

### Discussion

The treatment of joint and muscle-tendon injuries by platelet gel is one of the most innovative techniques and generally appreciated by either patients reporting an overall recovery benefits either by clinicians who are studying the effects of tissue repair.

As defined by our protocol, the clinical and instrumental evaluation of response to treatment showed a different distribution of the sample over time (Figure 9):

- NR (No response): 32% of gonarthrosis and 75% of coxarthrosis treated showed no pain reduction and joint inability and absence of echo-ultrasonographic evidence of tissue repair.
- PR (Partial Response) This group includes the 68% of gonarthrosis and 25% of coxarthrosis treated. In this category are included most of the tendon lesions treated: like 50% of patellar tendon injury, 69% of supraspinatus tendon injury, 60% of the meniscus, 50% of injuries to the Achilles tendon and 36% of muscle damage.

- CR (Complete Response) This type of response is characteristic of the treatment of tendon injuries (27% of the lesions of the supraspinatus tendon, 33% of injuries to the patellar tendon, 50% of the lesions of the Achilles tendon), the meniscus (20%) and muscle injury (64%). No coxarthrosis and gonarthrosis issued complete responses.

Regarding to correlation between response to infiltration with platelet gel and gender/age of the patients, the data showed age dependent stratification for treated lesions (arthritic conditions and large joints condition regard a population little older, while the ligament and tendon injuries are more frequent in younger subjects), but the clinical results appear not influenced by the age and the gender of the patient: in particular the success of the treatment is age/gender independent and only in one case in which the treatment did not gain any effect, the older age might have been associated to the result.

Our data highlight that recovery ability and pain relief on muscles, tendons and ligaments depend on tissue

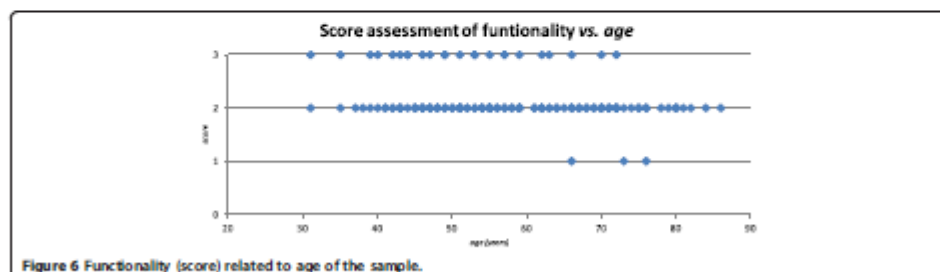

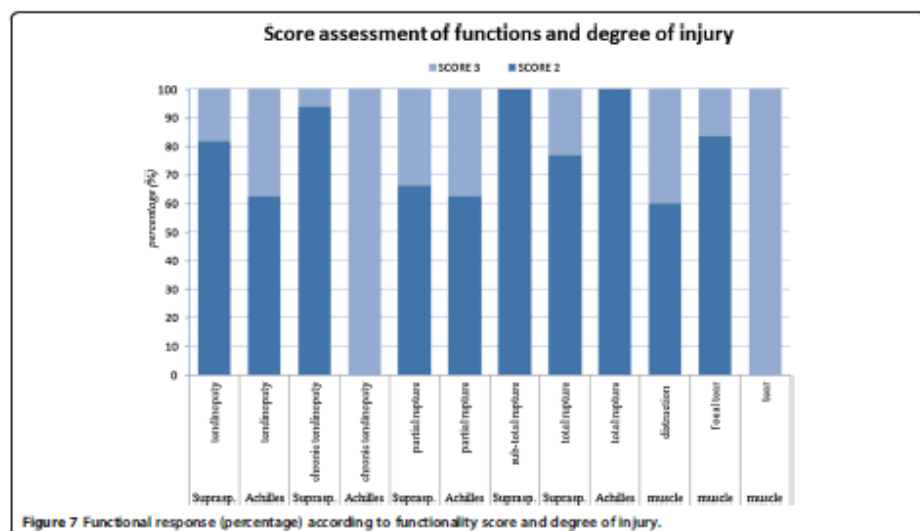

repair detectable with echo ultrasonographic evidence. However this seems to not affect the large joints (hip and knee) where the arthritis and/or corrosion of articular cartilage phenomena are not influenced by the infiltration process. Nonetheless, on large joints, the pain relief effect is exclusively linked to the reduction of

periarticular inflammation (reduction of inflammatory leakage and inflammatory status).

The rationale of this observation lays on some aspects of the pathology of the large joints and combined with the effect of platelet gel: in fact, the cartilage is a non-vascularized and not innervated tissue, lacking a

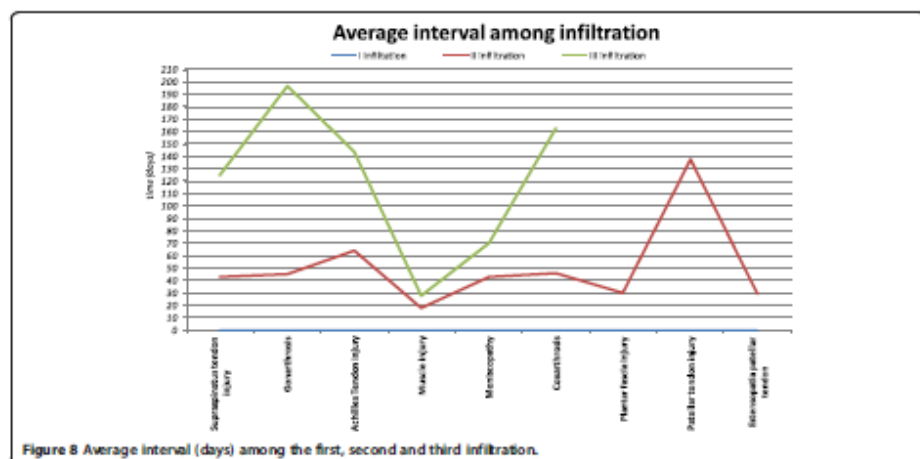



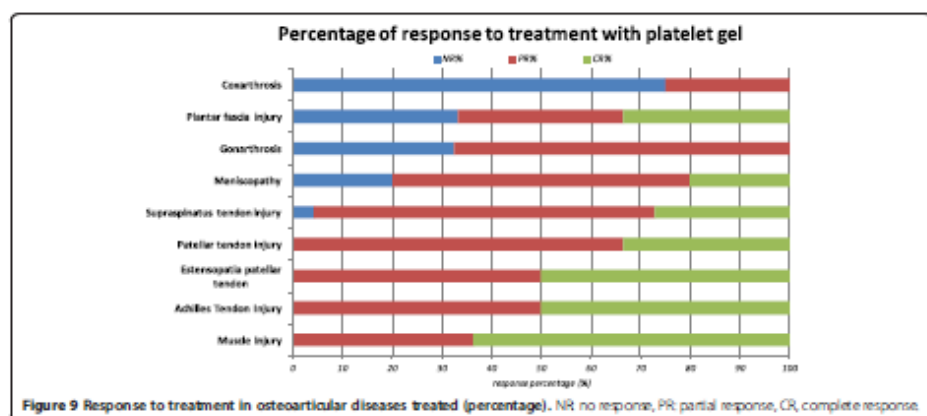

Figure 9 Response to treatment in osteoarticular diseases treated (percentage). NR, no response; PR, partial response; CR, complete response.

draining lymphatic system and with limited regenerative ability [20].

The arthritis process is a condition characterized by an unbalanced anabolic and catabolic processes at the articular surface of the synovial joint that result in progressive damage of the cartilage that brings to physical disability [21].

One of the most important inflammatory mediators involved in the arthritic process is represented by IL-1 $\beta$ , capable of inducing the production of proteases and able to inhibit the formation of extracellular matrix. A recent study [22] on in vitro cell cultures of human chondrocytes, has highlighted the role of IL-1 $\beta$  which plays a key role in the pathogenesis of osteoarthritis since determines significant changes in cytokine and chemokines genes expression involved in inflammation and matrix degradation. IL-1 $\beta$ , that exerts its effect through a broad spectrum of signals cascade, is activated by NF- $\kappa$ B (nuclear factor kappa B) and it in turn enhances its translocation into the nucleus [23].

Normally NF- $\kappa$ B is, in fact, located in the cytosol bound to an inhibitory protein and once activated it translocates to the nucleus where it plays in the regulation of more than 150 regulatory genes involved in apoptosis, inflammation, and in immune response [24].

The degranulation of the platelet gel acts on IL-1 $\beta$  mostly by the inhibition of translocation NF- $\kappa$ B into the nucleus of chondrocytes. Many drugs act as inhibitors of NF- $\kappa$ B including as glucocorticoids, so platelet gel could be used to balance the anabolic/ catabolic effect present in bone and joint disease [25].

Another important aspect, concerns the effect of platelet gel on the production of nitric oxide (NO).

In osteoarthritic disease IL-1 $\beta$ , as well as activates NF- $\kappa$ B, determines increased production of NO. The

excess of NO either inhibits the synthesis of collagen and glycosaminoglycans, either induces apoptosis of chondrocytes and the production of metalloproteases [26]. The control of this mechanism is connected to TGF- $\beta$  (platelet gel contained) which promotes the deposition of collagen and fibroblast proliferation and to the inhibitor role of NF- $\kappa$ B which, in turn, reduces the described effects of IL-1 $\beta$ .

The platelet gel therefore inhibits the IL-1 $\beta$  effects in osteoarthritic chondrocytes, so determining a substantially anti-inflammatory and analgesic effect. Thus, the application of platelet gel on osteoarthritis lesions can improve the quality of the synovial fluid through the induction of endogenous secretion of hyaluronic acid by the synovial cells [27].

However different considerations must be applied to the ligament and tendon injuries in which the platelet gel has the ability to deeply promote tissue regeneration.

The natural history of a pull or a bruise muscle, determines the formation of an hematoma (as a consequence of vascular destruction) that contains about 94% of red blood cells, less than 1% of leukocytes and a small part of platelets (approximately 4%) therefore representing inadequate environment to provide a stimulus for tissue regeneration. The rational use of platelet gel consists in the possibility of bringing to the lesion a large concentration of platelets and released growth factors that directly or indirectly promote tissue repair by inducing myogenesis and supporting muscle contraction [28,29].

The tendon cells (tenocytes and tenoblast) have a central role in repairing and maintaining extracellular matrix integrity by new protein and degrading enzyme synthesis. These processes underlie the turnover, remodeling and the gradual transformation of extracellular matrix that usually occur before the tendon rupture.

The activity of tendon cells are influenced by cytokines and growth factors released by platelet gel (especially VEGF and HGF) that act in a paracrine manner [29].

The initial phase of process repair starts with the vascular formation that seems playing a key role in the "restitutio ad integrum" of the lesion followed by tenocytes and fibroblast proliferation [30]. The GFs contained in the platelet gel (TGF- $\beta$ , PDGF, VEGF, EGF, HGF) interacting with specific receptors located on the membranes of target cells activate intracellular signal transduction pathways and induce the synthesis of proteins involved in angiogenesis and in the formation of extracellular matrix.

Furthermore, the platelet gel contains adhesion molecules (such as fibrin, fibronectin, vitronectin, thrombospondin, osteocalcin and osteonectin) that permits cell activation and movement of the precursor cells at the site of lesion [28].

All this process can repair connective and/ or bone tissue by increasing fibroblasts activates macrophages and stimulates new vessels formation which restore blood flow allowing nutrients and oxygen perfusion in order successfully repair the tissue [4-6].

Given these properties, platelet gel is crucial in the tendons, muscles and ligaments repair, acting on the regenerative stimulus.

Accordingly, in literature [31] it has been demonstrated that the use of platelet gel in the treatment of "tennis elbow" gives therapeutic advantages in terms of pain relief and ability recovery. A comparative case-control study on patients infiltrated with platelet gel and patients infiltrated with cortisone showed that treatment with cortisone quickly gives effect but quickly enough it disappears. On the contrary the benefit of platelet gel treatment slowly increases and tend to be maintained over time [32].

The same result is confirmed by the response to treatment of supraspinatus tendon lesions where patients infiltrated with platelet gel acquire better physical ability recovery in terms of motility and pain reduction and this is maintained over time even after six months from the treatment compared to control group [22,33].

Besides that, many aspects of the production and application of platelet gel are fully understood by the scientific community. The definition of the optimal dose, the amount and the time interval of infiltration remains under debate, because it does not exist a single standard protocol of treatment. The preparation and administration of platelet gel is established by clinical needs, type of pathology and the experience of the operator.

## Conclusions

Regenerative medicine can be considered one of the final frontier for the treatment of many diseases, and it

represents a new philosophy to approach tissue/ organ damage using the principle of biological regeneration [5]. Platelet gel is a new approach to tissue regeneration and it is becoming a valuable adjunct to promote healing in many procedures, especially in ageing patients [34]. In particular, in our opinion, platelet gel can be considered as an additional and integrative therapy to support conventional treatments for bone, joint and tendon injuries of different etiology because platelet gel therapy often resulted in pain relieve and significant physical ability. Regardless of whether or not the gel platelet can determine a complete tissue repair, it is doubtless that the therapy promotes analgesic effect with at least a reduced intake of anti-inflammatory drugs.

In our series of elderly patients, it seemingly does not work well because they are mainly affected by long lasting osteoarthritis with irreversible damage to cartilage.

From our observation is difficult to dissect if the contribution of the platelet gel depends on the number of infiltrations or other variables related to treatment, but it seems more likely that the response can be highly variable and extremely subjective.

It is clear that the general clinical condition of the patient (obesity, metabolic syndrome, advanced age, neurodegenerative disorders, strenuous physical activity, concomitant orthopedic disorders) might aggravate the osteoarticular pathology and expose the patient to a poor response or risk relapses.

Secondly, it is recognized by the scientific community [25] the individual variability and the capacity to produce GFs and releasing them into the injury site, which obviously causes a different biological inter-individual response.

Finally, the lacking of universally standardized and detailed protocols for the various bone and joint diseases (for both aspects of the production, and for those relating to the application of the gel) can be responsible for the extreme variability in the therapeutic response.

In view of the beneficial effects that gel platelet determines to tendon and joint lesions, we believe that the creation of a multicenter randomized study can increase and expand the clinical records of treated individual in order to refine and standardized certain aspects of this research.

Furthermore, it would be desirable to define a project that allows to correlate the compliance of the patient, the platelet concentration in the platelet gel and the amount of growth factors contained in it to identify any adjustable variables.

In addition, we have to take into account the possibility of a placebo effect since the expectation of a therapeutic result can activate specific brain regions and these same expectations can sometimes be the actual cause of clinical improvement. However, a complete

assessment of a placebo effect for this kinds of treatment it is very complicate, because like acupuncture studies, should include the study of 3 arms (treatment, sham treatment, open placebo) with the imaging of cerebral area involved [35,36].

#### Subjects, materials and methods

##### Sample studied

In four years of activities (October 2009-First week of August 2013) the Unit of Transfusion Medicine has carried out the treatment with platelet gel of 140 patients (66 females and 74 males) who shared the osteoarticular pain. The treated diseases are reported in Table 1. The age ranged from 26 to 86 years old, with an average of 58 years which was slightly different between genders (mean age for females: 62 years old, mean age for males 53 years old). It was not set up a control group to test treatment versus placebo.

Patients were enrolled using interviewed protocol and scheduled for infiltration ultrasound-echo guided before and after gel platelet infiltration. University hospital Ethics Committee approved the study protocol, and each participant signed an approved informed consent form.

At enrolment, the patients were interviewed to obtain clinical and pharmacological information; blood sampling was performed to acquire the suitability for pre-deposit of whole blood (Hb  $\geq$  12 g/dl, platelet count  $>$  200,000/ $\mu$ l) and to assess the healthy state (clinical chemistry tests and virological screening to hepatotropic viruses and HIV).

The criteria for exclusion from the study protocol were:

- Platelet count less than 200,000 plts/L.
- Hemoglobin count less than 11gr/dl.
- Cardiac disease and clinical evaluation unfavorable to the autologous blood donation.
- Vascular access not suitable to pre-deposit autologous blood donation.
- Inability to suspend antiplatelet and/or anticoagulant therapy.
- Previous infiltration or surgical treatment in the places of the injury.

##### Materials

Informed consent was obtained from the suitable patients, as well as 350 ml of predeposited autologous whole blood that was collected in quadruple Fresenius Kabi bag.

The production of platelet gel from blood components was performed at the laboratory of Transfusion Medicine of University Hospital "Paolo Giaccone". Whole blood was centrifuged and separated in order to obtain (through decomposer automatic Compomat G4 Fresenius HemoCare Italy) concentrated platelet and platelet-free

plasma (PPP). From the PPP sample, after rapid freezing ( $-40^{\circ}\text{C}$ ) followed by a slow thawing (12 hours), cryoprecipitate was collected. Thrombin has been prepared, adding 20 ml of calcium to the supernatant (PPP suite of cryoprecipitate) under a laminar flow hood. The "home made" platelet gel was dispensed into three aliquots containing 8–10 ml platelet concentrate and cryoprecipitate and three aliquots, of equal volume, containing autologous thrombin. The compounds were validated, stored at  $-20^{\circ}\text{C}$  and used within one year from date of manufacture.

##### Clinical protocol

The study protocol is divided into five different steps: 1) first visit to assess the suitability of the patient to the procedure, 2) second visit in order to obtain the pre-deposit of autologous blood donation 3) production of platelet gel 4) echo ultrasound-guided infiltration at the site of injury 5) clinical-instrumental evaluation of infiltration at different defined time.

The ultrasound-echo guided infiltration of platelet gel was performed by the medical team at specialized orthopedic structure (Medical Center Manta-CMM) collaborating with the University Hospital.

At the time of infiltration, the platelet gel was activated into a common 20 ml sterile syringe mixing the lysate and platelet thrombin at the ratio of 2:1. Once ready the platelet gel was injected by ultrasound-echo guided infiltration (Esacote My lab) keeping a perpendicular direction to site of the lesion. The amount of platelet lysate infiltrated was approximately 8–10 ml in volume. At the end of treatment, the patient rested in immobility for at least 48 hours.

The assessment on the evolution of the lesion was examined in three time points:

- T0: before treatment.
- T1: after 8 days from infiltration for lesion due to muscle damage, after 15 days for ligament and tendon injuries-after 30 days for treatment of the large joints.
- T2: more than 60 days after infiltration.

During these phases test for pain estimation (VAS), test for joint flexibility (ROM scale) were administered and echo-ultrasound evaluation at the site of infiltration was performed.

With regard to the assessment of pain, each patient was asked to conduct a self-assessment using the VAS (Visual Analog Scale) test.

The VAS test is a continuous scale comprised of a horizontal (HVAS) or vertical (VVAS) line, usually 10centimeters (100 mm) in length, anchored by verbal descriptors for each symptom intensity: the scale is anchored by "no pain" (score of 0) and "pain as bad as it



could be" or "worst imaginable pain" (score of 10-100-mm scale-).

The pain response was considered significant when the reduction was at least 50% of the score of the VAS scale a T1 (at a distance of 8 days from the first infiltration for muscle damage, at a distance of 15 days for those ligament and tendon and at a distance of 30 days for large joints).

To estimate the degree of joint flexibility, the medical team used the ROM (Range Of Motion) scale which allows evaluation of the degrees of freedom allowed by a specific articulation. The ROM is usually measured by the number of degrees achieved by a body segment from the starting position to the final position, along its full range of motion and is calculated using a protractor.

Based on ROM assessment is possible to identify three levels: 1) AROM: active range of movement, 2) AAROM: active assisted range of motion; 3) PROM: passive range of motion.

With respect to the functional/joint limitation and the resolution at the injured site after platelet gel application, we chose to use a three points score:

- Score 1: no changed condition from the beginning of treatment.
- Score 2: increase joint ability to perform task but not fully "restitutio ad integrum".
- Score 3: Complete functional recovery.

The reaction over time was determined in three types of responses:

- No response (NR): permanence of pain and functional limitation and no echo-ultrasonographic evidence of tissue repair.
- Partial response (PR): reduction of pain and/or functional limitation and no or little evidence of ultrasound tissue repair.
- Complete response (CR): important reduction of pain and complete restoration of function with clear ultrasound evidence of tissue repair.

Based on the response to treatment, the medical team evaluated additional indication for further infiltration and established the subsequent time intervals to follow.

#### Data analysis

The data collected were represented as mean value. The results of the clinical responses were represented as absolute and relative frequencies (%).

#### Competing interests

The authors declare that they have no competing interests.

#### Authors' contributions

CR drafted the paper. All authors edited the paper and approved its final version.

#### Acknowledgements

This work was supported by Grants from Palermo University to Calogero Caruso (FFR101/2/2013 Role of Immuno-Inflammatory Responses in Successful Ageing). CR is PhD student of the PhD course in Molecular Medicine directed by CC and this paper is submitted in partial fulfillment of her degree. A heartfelt thank you to Fabrizio Mantia and Marcello Mantia who have made possible the collaboration between the companies and the success of the project.

#### Author details

<sup>1</sup>Unit of Transfusion Medicine, University Hospital "Paolo Giaccone", Palermo, Italy. <sup>2</sup>Department of Pathobiology and Medical and Forensic Biotechnologies, University of Palermo, Palermo, Italy. <sup>3</sup>Mantia Medical Center, Palermo, Italy. <sup>4</sup>Department of Legal Sciences, Society and Sport, Palermo, Italy. <sup>5</sup>Department of Science and Biological, Chemical and Pharmaceutical Technologies, University of Palermo, Palermo, Italy. <sup>6</sup>National Center for Research, Institute of Biomedicine and Molecular Immunology, Palermo, Italy.

Received: 14 November 2014 Accepted: 19 November 2014

Published online: 02 December 2014

#### References

1. Nighon DR, Cinesi K, Regal VD, Schumert S, Butler E, Cirra P. Stimulation of repair in chronic, nonhealing, cutaneous ulcers using platelet-derived wound healing formula. *Surg Gynecol Obstet* 1990, **170**:56-60.
2. Lucantelli E, Becheroni A, Donati D, Sangiorgi L, Conacchi A, Del Vento AM, Meoni C, Bertoia AZ, Giardino R, Formasi PM, Mercuri M, Picci P. Platelet-derived growth factors enhance proliferation of human stromal stem cells. *Biomaterials* 2003, **24**:3095-3100.
3. Tang YQ, Yeaman MR, Selsted ME. Antimicrobial peptides from human platelets. *Infect Immun* 2002, **70**:6524-6533.
4. Kusuda J, Butterfield CE, Duda DG, Eichenberger SC, Saffarpour S, Ware J, Ruggeri ZM, Jain RK, Folkman J, Wagner OD. Platelets and platelet adhesion support angiogenesis while preventing excessive hemorrhage. *Proc Natl Acad Sci U S A* 2006, **103**:855-860.
5. Bonfi G, Corsi MM. Regenerative medicine. *J Biol Regul Homeost Agents* 2011, **25**(2):5151.
6. Gallera E, Corsi MM, Bonfi G. Platelet rich plasma therapy: inflammatory molecules involved in tissue healing. *J Biol Regul Homeost Agents* 2012, **26**(5):355-425.
7. Dallari D, Savarino L, Stagni C, Conni E, Conacchi A, Formasi PM, Albinetti U, Rimondi E, Baldini N, Giusti A. Enhanced tibial osteotomy healing with use of bone grafts supplemented with platelet gel or platelet gel and bone marrow stromal cells. *J Bone Joint Surg Am* 2007, **89**:2413-2420.
8. Chang SH, Hu YM, Wang YL, Tso YP, Tung KY, Wang TY. Fabrication of pre-determined shape of bone segment with collagen-hydroxyapatite scaffold and autogenous platelet-rich plasma. *J Mater Sci Mater Med* 2009, **20**:23-31.
9. de Obarrio JJ, Araiza-Duñari J, Chamberlain TM, Creston A. The use of autologous growth factors in periodontal surgical therapy: platelet gel biotechnology - case reports. *Int J Periodontics Restorative Dent* 2003, **20**:486-497.
10. Arisua E, Sanchez M, Nurdin AT, Zaldueño M, de la Fuente M, Orive G, Azofra J, Andia J. Autologous fibrin matrices: a potential source of biological mediators that modulate tendon cell activities. *J Biomed Mater Res A* 2006, **77**:285-293.
11. Taylor M, Norman T, Clavis N, Baha D. The response of rabbit patellar tendons after autologous blood injection. *Med Sci Sports Exerc* 2002, **34**:70-73.
12. Mishra A, Pavetto T. Treatment of chronic elbow tendinosis with buffered platelet-rich plasma. *Am J Sports Med* 2006, **34**:1-5.
13. Mishra A, Woodal J Jr, Mishra A. Treatment of tendon and muscle using platelet-rich plasma. *Clin Sports Med* 2009, **28**:113-125.
14. Gardner MJ, Demetropoulos D, Neppich P, Mocar P. The efficacy of autologous platelet gel in pain control and blood loss in total knee

- arthroplasty: an analysis of the haemoglobin, narcotic requirement and range of motion. *Int Orthop* 2006, **31**:309–313.
15. Sampson S, Gehardt M, Mandelbaum B: Platelet rich plasma injection grafts for musculoskeletal injuries: a review. *Curr Rev Musculoskelet Med* 2008, **1**:165–174.
  16. Jang SJ, Kim JD, Cha SS: Platelet-rich plasma (PRP) injections as an effective treatment for early osteoarthritis. *Eur J Orthop Surg Traumatol* 2013, **23**:573–580.
  17. Patel S, Dillon MS, Aggarwal S, Marwaha N, Jain A: Treatment with platelet-rich plasma is more effective than placebo for knee osteoarthritis: a prospective, double-blind, randomized trial. *Am J Sports Med* 2013, **41**:355–364.
  18. Filardo G, Kon E, Di Martino A, Di Matteo B, Merli M, Conacchi A, Fornacek PM, Marcacci M: Platelet-rich plasma vs hyaluronic acid to treat knee degenerative pathology: study design and preliminary results of a randomized controlled trial. *BMC Musculoskelet Disord* 2012, **13**:229.
  19. Moraes VY, Lenzi M, Tamaoki MJ, Faloppa F, Bellodi JC: Platelet-rich therapies for musculoskeletal soft tissue injuries. *Cochrane Database Syst Rev* 2014, **4**:CD010071. doi:10.1002/14651858.CD010071.pub3.
  20. Stohrer AF, Ghivizzani SC, Rothwilm A, Tuan RS, Evans CH, Nöth U: Major biological obstacles for persistent cell-based regeneration of articular cartilage. *Arthritis Res Ther* 2007, **9**:213.
  21. Looser RF: Molecular mechanisms of cartilage destruction in osteoarthritis. *J Musculoskelet Neuronal Interact* 2008, **8**:303–306.
  22. Peeterbooms JC, Sluiter L, Bruijn DJ, Gosens T: Platelet-rich plasma versus corticosteroid injection with a 1-year follow-up. *Am J Sports Med* 2010, **38**:255–262.
  23. van der Kraan PM, van den Berg WB: Anabolic and destructive mediators in osteoarthritis. *Curr Opin Clin Nutr Metab Care* 2000, **3**:205–211.
  24. Ishinaga H, Jono H, Lim JH, Komatsu K, Xu X, Lee J, Woo CH, Xu H, Feng XH, Chen LF, Yan C, U JD: Synergistic induction of nuclear factor-kappaB by transforming growth factor-beta and tumour necrosis factor-alpha is mediated by protein kinase A-dependent RelA acetylation. *Biochem J* 2009, **417**:583–591.
  25. van Buul GM, Koozevt WL, Kops N, Bos PK, Verhaar JA, Weirans H, Berman MR, van Ock GJ: Platelet-rich plasma release inhibits inflammatory processes in osteoarthritic chondrocytes. *Am J Sports Med* 2011, **39**:2362–2370.
  26. Vuolteenaho K, Mollanen T, Jalonen U, Lahti A, Nieminen R, van Bunningen HM, van der Kraan PM, Mollanen E: TGFbeta inhibits IL-1-induced iNOS expression and NO production in immortalized chondrocytes. *Inflamm Res* 2005, **54**:420–427.
  27. Anitua E, Sanchez M, Nurdin AT, Zaldumbide MM, de la Fuente M, Azofeifa J, Andia I: Platelet-released growth factors enhance the secretion of hyaluronic acid and induce hepatocyte growth factor production by synovial fibroblasts from arthritic patients. *Rheumatology (Oxford)* 2007, **46**:1769–1772.
  28. Nurdin AT, Nurdin P, Sanchez M, Andia I, Anitua E: Platelets and wound healing. *Progr Biophys* 2008, **13**:353–358.
  29. Mei-Dan Q, Lippi G, Sanchez M, Andia I, Maffulli N: Autologous platelet-rich plasma: a revolution in soft tissue sports injury management? *Phys Sportsmed* 2010, **38**:127–135.
  30. Singer I, Richard AF, Clark MD: Cutaneous wound healing. *N Engl J Med* 1999, **341**:738–746.
  31. Taylor DW, Petroni M, Hendry M, Theodoropoulos JS: Systematic Review of the Use of Platelet-Rich Plasma in Sports Medicine as a New Treatment for Tendon and Ligament Injuries. *Clin J Sport Med* 2011, **21**:344–352.
  32. Maniscalco P, Gambera D, Lunati A, Vox G, Fossombroni V, Boretta R, Craire E: The "Cascade" membrane: a new PRP device for tendon ruptures. Description and case report on rotator cuff tendon. *Acta Biomed* 2008, **79**:223–226.
  33. Marx RE: Platelet-rich plasma: Evidence to support its use. *J Oral Maxillofac Surg* 2004, **62**:489–496.
  34. Albanese A, Licata ME, Polizzi B, Campiti G: Platelet-rich plasma (PRP) in dental and oral surgery: from the wound healing to bone regeneration. *Immun Ageing* 2013, **10**:23.
  35. Benedetti F: *The Patient's Brain: the Neuroscience Behind the Doctor-Patient Relationship*. Oxford, U.K: Oxford University Press; 2011.
  36. Canoso C, Rizzo C, Vantini I: *Insegnare nelle Università in Fisioterapia e Agopuntura?* *Med Chir* 2013, **60**:2668–2678 (in Italian).

doi:10.1186/s12979-014-0021-9

Cite this article as: Rizzo et al.: The role of platelet gel in osteoarthritic injuries of young and old patients. *Immunity & Ageing* 2014, **11**:21.

Submit your next manuscript to BioMed Central and take full advantage of:

- Convenient online submission
- Thorough peer review
- No space constraints or color figure charges
- Immediate publication on acceptance
- Inclusion in PubMed, CAS, Scopus and Google Scholar
- Research which is freely available for redistribution

Submit your manuscript at  
www.biomedcentral.com/submit



## **5. Possible role of ABO system in age-related diseases and longevity: a narrative review**

REVIEW

Open Access

## Possible role of ABO system in age-related diseases and longevity: a narrative review

Claudia Rizzo<sup>1,2\*</sup>, Calogero Caruso<sup>1,2</sup> and Sonya Vasto<sup>3,4</sup>

### Abstract

ABO blood group antigens are expressed either on the surface of red blood cells either on a variety of other cells. Based on the available knowledge of the genes involved in their biosynthesis and their tissue distribution, their polymorphism has been suggested to provide intraspecies diversity allowing to cope with diverse and rapidly evolving pathogens. Accordingly, the different prevalence of ABO group genotypes among the populations has been demonstrated to be driven by malaria selection. In the similar manner, a particular ABO blood group may contribute to favour life-extension via biological mechanisms important for surviving or eluding serious disease. In this review, we will suggest the possible association of ABO group with age-related diseases and longevity taking into account the biological role of the ABO glycosyltransferases on some inflammatory mediators as adhesion molecules.

**Keywords:** ABO, Cancer, Cardiovascular diseases, Inflammation, Longevity

### Introduction

There are accumulating evidences that the ABO blood antigens might play a key role in various human diseases [1]. Historically, the ABO phenotype was one of the first marker involved in cancer susceptibility [2,3], whereas the first association between Human Leukocyte Antigens (HLA) and disease was described more recently: the association involved a cross-reactive group of HLA-B antigens and Hodgkin's disease [4]. However, the identification of large numbers HLA-associated diseases counterpart our increased understanding of the genetic complexity of the HLA system and its extensive polymorphism [5], whereas data for ABO antigens are yet not so clear. The ABO molecules represent a complex membrane antigens widely expressed both on the surface of red blood cells (RBC) and many other cells extending the importance and the clinical significance of the ABO system beyond the transfusion medicine [6,7].

### The ABO system

The ABO antigen system occurs as a result of complex carbohydrate polymorphism mosaic of glycoproteins and

glycolipids expressed on the surface of cells, or present in secretions, as glycan units [6,7].

The A and B antigens are inherited as Mendelian characteristics in a co-dominant autosomal fashion. These antigens are the enzymatic products of enzymes called glycosyltransferases that in turn synthesize the oligosaccharide epitopes. Thus, the A and B antigens are made by A and B glycosyltransferase, respectively (A-synthesizing 3- $\alpha$ -N-acetylgalactosaminyltransferase and the B-synthesizing 3- $\alpha$ -N-galactosaminyltransferase) while the O allele does not encode for a functional transferase. In this last case, the acceptor substrate, (H antigen: Fuc  $\alpha$ 1-2 Gal) remains without a further modification and the A and B determinants are absent on surfaces of cells [6-8].

The A and B glycosyltransferases are type II membrane proteins located in the Golgi compartment, although soluble forms are found in plasma and other body fluids. The enzyme consists of a short transmembrane domain, a stem region and a catalytic domain that extends into the Golgi lumen. So, the A and B antigen synthesis occurs during normal glycosylation of proteins and lipids in the Golgi compartment. The precursor H substance is synthesized by one of two fucosyltransferases depending on the acceptor substrate used. The FUT1 gene that encodes the 2- $\alpha$ -fucosyltransferase ( $\alpha$ 2FucT1) is mainly responsible for the synthesis of the H antigen on carbohydrate precursors found on RBC. The closely related FUT2 gene

\* Correspondence: [claudia.rizzo@unipa.it](mailto:claudia.rizzo@unipa.it)  
<sup>1</sup>Unit of Transfusion Medicine, University Hospital "Paolo Giaccone", Palermo, Italy  
<sup>2</sup>Department of Pathobiology and Medical and Forensic Biotechnologies, University of Palermo, Palermo, Italy  
Full list of author information is available at the end of the article



© 2014 Rizzo et al.; licensee BioMed Central Ltd. This is an Open Access article distributed under the terms of the Creative Commons Attribution License (<http://creativecommons.org/licenses/by/4.0/>), which permits unrestricted use, distribution, and reproduction in any medium, provided the original work is properly credited. The Creative Commons Public Domain Dedication waiver (<http://creativecommons.org/publicdomain/zero/1.0/>) applies to the data made available in this article, unless otherwise stated.



encodes a very similar 2- $\alpha$ -fucosyltransferase ( $\alpha$ 2FucT2) that is expressed in epithelial cells [7,8].

As regards the organization of the ABO locus, the gene consists of seven coding exons and it is extended on 18 kb of genomic DNA. The sizes of the exons are included in a range of 28–688 bp, while the two major exons, 6 and 7, have a size of 1062 bp and contain most of the coding sequence. The single nucleotide deletion, found in a large number, but not all, of O alleles and responsible for the loss of the activity of the enzyme, is located in exon 6. The first of the seventh nucleotide substitutions, which distinguish the A, and B transferases, resides in coding exon 6. Exon 7 contains six nucleotide substitutions, resulting in four amino acid substitutions, that differentiate the A and B transferases [7,8].

ABO subgroups are distinguished by decreased amounts of antigens on RBC, so A2 subgroup RBC has less antigens than A1 subgroup (and so on for the other A and B subgroups). It is important to point out that the amount of antigens depends on glycosyltransferase activity [9].

The ABH sugars are found on lipids (approximately 10%) and proteins (approximately 90%) on the RBC surface as well as on many different tissues and cell types, including epithelial cells that line the lumen of the gastrointestinal, respiratory, and reproductive tracts as well as in salivary glands and skin. This wide distribution is a common feature for many of the carbohydrate blood groups, which has resulted in the term histo-blood group often being used to reflect this wide distribution. Accordingly, it has been suggested that these antigens, as the other glycoconjugates, are important mediators of intercellular adhesion and membrane signalling [7,8,10].

#### Ageing and longevity

The ageing and longevity processes are determined by different genetic, epigenetic, stochastic and environmental factors. Among others, evidences from epidemiological studies on family of twins and long-lived individuals suggest a strong role for genetics. However, if genetics covers the 25% of the overall variation in human life span, another 25% is dependent on socio-economic factors in childhood, while adulthood and old age, including the socio-economic status and medical care, events may represent the remaining 50%. In the Western world, the development of the social-economics conditions, as medical care and quality of life, are responsible of a general improvement of the health population status with a consequent reduction of the overall morbidity and mortality, resulting in an overall increase of life expectancy [11,12].

Ageing can be defined as a decline in performance and fitness with advancing age, creating difficulty in adapting to new environmental situations. The post-maturational ageing process, in fact, is characterized by a diminished homeostasis and vulnerability of the body, responsible

for a reduced response to environmental stimuli and stresses that lead to increased susceptibility and vulnerability to disease. Therefore, the mortality from all causes exponentially increases with age. In Western countries, the mortality rate increases in people over the age of 65, when compared with individuals between 25 and 44 years, because of heart disease (92 times), cancer (43 times), stroke (more than 100 times), chronic lung disease (greater than 100 times) and pneumonia and influenza (89 times), pointing out the role of the control of maintenance/repair systems as those involved in oxidative stress and immune-inflammatory responses, in the attainment of successful ageing [13–16].

Ageing is unnatural and damage is a fact of life. Ageing is not a programmed route but is a stochastic process resulting from accumulation of somatic damage implying a systemic loss of molecular fidelity. In ageing, the limited investments in maintenance and repair that are evolutionarily selected to assure reproduction and parental care brought to a minimal control of inflammation and oxidative stress. So, the ageing process is mostly stochastic, whereas the genome plays a role in determining longevity, which is regulated by the level of functional reserve reached at the time of reproductive age through natural selection. In other words, the effect of the duration of life is incidental because the main effect of the genome is to govern the events that occur until reproductive maturity [16–18].

Accordingly, demographic evidences suggest that longevity may be attained by different combinations of genes and environment with quantitative and qualitative differences in the different geographical areas where the population-specific genetic factors play a role in the longevity phenotype [19,20].

In this context, the study of centenarian offspring, a group of healthy elderly people with a familiar history of longevity, has helped gerontologists to better identify the correlation between genetic profile and hope of a healthy ageing. Previous studies have reported that centenarian offspring, like their centenarian parents, have genetic and immune system advantages, which reflect a minor risk to develop major age-related diseases, such as cardiovascular diseases (CVD), hypertension or diabetes mellitus as well as cancer [21,22].

Therefore, as previously stated, it is possible to assume that longevity may be influenced by polymorphisms of genes that control the immune-inflammatory responses as well as genes that modulate cardiovascular disease and cancer [20,23–25].

Different studies performed on mice have suggested that the Major Histocompatibility Complex (MHC), known to control a variety of immune functions, is associated with the life span of the strains. Hence, several studies have been performed in humans by analysing loci that regulate the immune response, as human MHC (HLA) and killer



cell immunoglobulin-like receptor (KIR) genes regulating the cytolytic activity of natural killer cells. On the whole, the results suggest that HLA/KIR/longevity associations are population specific, being heavily affected by the population-specific genetic and environmental history [26-29].

In addition, as previously stated, alleles associated to CVD and cancer susceptibility have been shown to be not included in the genetic background favouring longevity, at least in some population, depending on the environmental stimuli [20,23].

#### **ABO and age related diseases**

Over the time, several studies have tried a possible association between ABO groups and diseases although with contrasting results [1,9,30,31]. Many of the performed studies present serious challenges because of a number of confounding factors [32]: i) the incorrect sample size leading to selection bias and false positive associations (i.e. the lack of statistical power); ii) different inclusion criteria, unsuitable mixing of data (cohort effects) referred to people of different age, incorrect control matching, i.e. lack of selection from the same target population (stratification); iii) linkage disequilibrium, i.e. the associated ABO group may play no direct role, and the actual disease-predisposing polymorphism may be in linkage disequilibrium with the initially reported ABO association, which merely acts as a marker. Therefore, we will here report only the associations that have been confirmed relating to age-related diseases, cancer and CVD.

Cancer is generally recognized as an age-related disease [23,33]. In fact, incidence and mortality rates of most human cancers consistently increase with age up to 90 years, although they thereafter plateau and decline. The largest number of cancer cases occur in over 65 years in both sexes: the incidence of cancer is 12–36 times higher in subjects over 65 years compared to individuals aged between 25–44 years and 2–3 times more common than people aged between 45–64 years. The multistage model of carcinogenesis provides insight into the relationship between ageing and carcinogenesis, since ageing could be considered not so much as a determinant of cancer but as the condition, which results in a longer duration of exposure to carcinogens [23]. However, a low-grade systemic inflammation characterizes ageing and this pro-inflammatory status may underlie biological mechanisms responsible for age-related inflammatory diseases [14,24]. Clinical and epidemiological studies, in fact, show a strong association between chronic infections, inflammation and cancer and indicate that, even in tumours not directly linked to pathogens, the microenvironment is characterized by the presence of a smouldering inflammation, fuelled both by stromal leukocytes and senescent cells characteristic of ageing [23,24,34]. Therefore,

the higher incidence of cancer in ageing could be due to pro-inflammatory state of ageing [23]. In any case, cancer and ageing are both fuelled by the accumulation of cellular damage, so they can simultaneously proceed [33].

Several studies have looked for the association between ABO blood group and cancer, however there are only evidences for pancreatic and gastric cancer [9,30,31].

The association with pancreatic cancer can be traced back to the 1960 study of Aird [35] who in 620 patients with pancreatic cancer found evidence of some strength that cancer of the pancreas is commoner in persons of group A than in persons of groups O or B. Following this pioneering study, in the following years many studies have been performed. As reviewed by Liunbruno and Franchini [9,30,31], cohort, case-control and meta-analysis studies clearly demonstrate the role of ABO blood group in pancreatic cancer. In particular, it is become clear the protective effect of O group and the association with A1 allele. The evidence that A1 allele, responsible for an increased glycosyltransferase activity, confers greater pancreatic cancer risk than A2 allele, focus on the biological role of glycans, as potential mechanism to explain the association, since glycoconjugates, such as ABO antigen, are important mediators of intercellular adhesion and membrane signaling, which are both critical to the progression and spread of malignant cells [10,36].

Concerning gastric cancer, also in this case, as stated in the Introduction, the pioneering study was performed by Aird [2], which in 1953 on 3,632 patients, highlighted a 20% increase of carcinoma of the stomach in group A as compared to group O. As discussed by Liunbruno e Franchini [9,30,31], most of the studies have confirmed that the risk of gastric cancer in blood group A is significantly higher than in non-A groups. Concerning the mechanisms, it has to point out that ABO blood group is a risk factor for progression towards gastric cancer in patients with *Helicobacter pylori* (Hp) infection, since in the gastric epithelium, the ABO blood groups antigens are one of the major functional receptor for Hp [36,37]. The association seems to be highly dependent on Hp cytotoxin associated gene (CagA) status, which is responsible for the secretion of the CagA virulence protein that, injected in the host cell cytosol, plays a relevant role in the precancerous lesion development. This might account for the lack of association in studies that did not take into account the prevalence of Hp infection in the population under study [36].

As regards age-related CVD, an important role is played by atherosclerotic disease, one of the main causes of mortality worldwide. Atherosclerosis is a chronic, progressive, multifactorial disease mostly affecting large and medium-sized elastic and muscular arteries: fatty-streak lesions are initiated by the accumulation of monocytes in sub-endothelial spaces, where they develop into lipid-laden

macrophages, otherwise known as foam cells. Currently, multiple independent pathways of evidences suggest this pathological condition as a peculiar form of inflammation, triggered by cholesterol-rich lipoproteins and other noxious factors, such as cigarette smoke, diabetes mellitus and hypertension. Inflammation seems, indeed, to be the prevalent process of atherosclerosis, evoked by multiple risk factors and responsible for the altered arterial biology associated with atherosclerosis complications [20,38,39].

The initial stimulus inducing the inflammatory process has not yet been fully identified. However, endothelial dysfunction plays a crucial role in inflammation evocation. Several causes are associated with endothelial dysfunction, including the major number of traditional atherosclerosis risk factors, i.e. elevated low density lipoprotein values, free radicals caused by cigarettes smoking, hypertension, diabetes, elevated levels of homocysteine. Infections caused by Chlamydia pneumoniae, Herpes simplex virus, Cytomegalovirus and Hp also have been claimed to play a key factors in the disease. Thus, atherosclerosis may be considered as a characteristic response both to endothelium injury and to the consequent endothelial dysfunction. Endothelial dysfunction leads to compensatory responses modifying the normal homeostatic properties of the endothelium and favouring the expression of adhesion molecules, which, by binding to various classes of leukocytes, play a key role in the atherosclerotic process [20,38-41].

Complex interactions among the resident endothelial cells, the smooth muscle cells and the infiltrating monocytes and T lymphocytes determine the progression of fatty streaks into vascular lesions that block the normal blood flow and ultimately end into rupture of the atherosclerotic plaque, leading to either myocardial infarction or stroke [20,38,39].

However, the inflammatory process has a strong heritable component. Thus, the analysis of the genes that are key nodes of the inflammatory response might in part clarify the pathophysiology of atherosclerosis and its complications [14,20,24].

Several studies have documented the influence of ABO blood groups on plasma von Willebrand factor (VWF) levels, hence of factor VIII plasma levels. ABH oligosaccharide structures have been identified on the N-linked oligosaccharide chains of VWF located in the A1 domain, which contains the binding site for platelet glycoprotein Ib. The VWF levels are approximately 25% higher in individuals who have a blood group other than O and it might depend on endothelial A, B glycosyltransferase enzymes, which generate A and B antigens, on the existing VWF "H" oligosaccharides. This addition to VWF might, in turn, influence its blood level [9,31,42-44].

On this basis, it is not surprising that a possible association between CVD and ABO blood group has been pointed out by several case-control, retrospective and

meta-analysis studies. Although, most studies show an increased risk for CVD in subjects carrying non-O blood groups, there are conflicting results suggesting that the issue of the association between ABO blood group and CVD need further investigations [9,31]. On the other hand, large-scale genomic studies (GWAS) have revealed a central role for ABO antigens and blood levels of inflammatory mediators as soluble adhesion molecules, demonstrating that group O individuals show higher levels of inflammatory mediators. This might be due to glycosyltransferases activity, which might negatively influence shedding/cleavage of inflammatory molecules from the endothelium [9,20,31,45,46], see also below. In any case, this could explain the inconsistent results obtained.

#### **ABO and longevity**

ABO antigens have been known for a long time and yet their biological meaning is still largely obscure [1,6]. Based on the available knowledge of the genes involved in their biosynthesis and their tissue distribution, their polymorphism has been suggested to provide intra-species diversity allowing to cope with diverse and rapidly evolving pathogens [1,6]. Accordingly, the different prevalence of ABO group genotypes among the populations has been demonstrated to be driven by malaria selection [1,47,48]. In the similar manner, a particular ABO blood group may contribute to favour life-extension via biological mechanisms important for surviving or eluding serious disease [6].

There are only five reports suggesting a possible association between ABO blood groups and ageing/longevity features, among those only two performed on centenarians and only one performed by molecular methods. In the first one, a significant increase of A blood type was observed in the healthy elderly male population over 64 years of age from UK [49], but it is not possible to consider this study for the very low age taken into account. In a study carried out on a small sample of very longevous Turkish population, no association was found [50]; however, the validity of age claims was very questionable because birth certificates were not available, so also this study cannot be considered.

A more recent study investigated the association between blood groups and life expectancy in Japanese population [51]. The authors compared frequencies of ABO blood groups in 269 centenarians living in Tokyo and those in 7153 regionally matched controls. Differences between centenarians and controls and between observed and expected frequencies were investigated by Chi Square tests. Group B was observed more frequently in centenarians than in controls, suggesting that group B might be associated with exceptional longevity. The authors suggested that group B individuals are more likely to survive age-related diseases rather than escape them, since 33% of the



centenarians were free of age-related diseases, but this did not correlate with the group B.

In a further study, to validate these results, Brecher and Hay [52] collected data on the ABO blood groups of patients who died in a United States tertiary care hospital over a 1-year period. If group B was a marker for a longer lifespan, it would be expected that the percentage of group B patients would rise with age at the time of death and those of other blood groups would decline. A total of 772 patients were included in the study and data were presented as ABO proportion stratified by age. The authors found that the percentage of group B patients declined with age, and this result was statistically significant. None of the other blood groups showed a statistically significant increase or decrease when plotted against decade of death. Overall, these results suggest that group B is not a marker for longevity, at least in US.

We have recently investigated [53] the relationship between ABO group and longevity in a small sample of homogeneous Sicilian centenarians ( $n = 38$ ) and young controls ( $n = 59$ ). Our group of centenarians (age range 100–107) had no cardiac risk factors or other age-related diseases. The control group (age range 45–65) was recruited from blood donors and judged to be healthy on the basis of clinical history and blood tests (complete blood cell count, erythrocyte sedimentation rate, glucose, urea nitrogen, creatinine, electrolytes, C-reactive protein, liver function tests, iron, proteins, cholesterol and triglycerides). Samples were genotyped by molecular biology to determine ABO blood group and Chi Square analysis was used to determine the statistical significance of differences in ABO of centenarians and controls. Our pilot study shows a not-significant increase of A1 allele in Sicilian centenarians.

## Conclusions

As previously stated, blood groups seem to influence serum level of soluble adhesion molecules in blood stream. In particular, it is interesting to note that levels of serum soluble E-selectin, which represents an inflammatory marker of several diseases, including CVD, are higher in O/O individuals, whereas a single nucleotide polymorphism in A1 allele is associated with low levels of these inflammatory markers. A recent GWAS conducted on level of inflammatory markers in the Sardinian population highlighted the association between CVD and ABO locus and the association was established between this locus and interleukin (IL)-6 gene. Subjects homozygous for G allele in rs657152 SNP, corresponding to blood type O carriers, showed higher IL-6 circulating levels respect to non-O carriers, although the reason is unknown, reinforcing a relevant involvement of blood group antigens in inflammatory process. Indeed, previous studies demonstrated that a

variant in ABO genes might explain the variation in soluble E-selectin levels [45,46,54–56].

As previously stated, several studies show that inflammatory gene variants, responsible for a low inflammatory response or a high anti-inflammatory response are associated with longevity, avoiding or delaying the onset of CVD [19–21]. In the generation of centenarians under study, the control of CVD, in fact plays a key role in the longevity attainment [19–21]. So, the Sicilian results, that need to be confirmed in a larger sample of centenarians, also taking into account the gender due to its relevance in immune-inflammatory responses [57], are in line with the previous statements. So, people carrying A1 allele should be advantaged in attaining longevity because of the lower levels of the serum soluble inflammatory marker E-selectin linked to this blood group, so avoiding or delaying cardiovascular events.

## Competing interests

The authors declare that they have no competing interests.

## Authors' contributions

CR drafted the paper. All authors edited the paper and approved its final version.

## Acknowledgements

This work was supported by Grants from Palermo University to Calogero Caruso (FR2012/2013 Role of Immune-inflammatory Responses in Successful Ageing). CR is PhD student of the PhD course in Molecular Medicine directed by CC and this paper is submitted in partial fulfillment of her degree.

## Author details

<sup>1</sup>Unit of Transfusion Medicine, University Hospital "Paolo Giaccone", Palermo, Italy. <sup>2</sup>Department of Pathobiology and Medical and Forensic Biotechnologies, University of Palermo, Palermo, Italy. <sup>3</sup>National Center for Research, Institute of Biomedicine and Molecular Immunology, Palermo, Italy. <sup>4</sup>Department of Science and Biological, Chemical and Pharmaceutical Technologies, Institute of Biomedicine and Molecular Immunology, Palermo, Italy.

Received: 23 September 2014 Accepted: 18 October 2014

Published: 1 November 2014

## References

1. Arstio DJ: The relationship between blood groups and disease. *Blood* 2010, **115**:4635–4643.
2. Aird I, Bentall HH, Roberts JA: A relationship between cancer of stomach and the ABO blood groups. *Br Med J* 1953, **1**:799–801.
3. Aird I, Bentall HH, Mehigan JA, Roberts JA: The blood groups in relation to peptic ulceration and carcinoma of colon, rectum, breast, and bronchus; an association between the ABO groups and peptic ulceration. *Br Med J* 1954, **2**:315–321.
4. Amici J: Study of the leukocyte phenotypes in Hodgkin's disease. In *Histocompatibility Testing 1967*. Edited by Curtoni ES, Mattiazzi PL, Tosi MR. Copenhagen, Denmark: Munksgaard, A/S; 1967:79.
5. Howell WM: HLA and disease: guilt by association. *Int J Immunogenet* 2014, **4**:1–12.
6. Moon T: An Examination of the Relationship of ABO Blood Group and Lifespan in a Hospitalized Population in the Southeastern United States. VCU Theses and Dissertations 2014 Paper 3348.
7. Storry JR, Olson ML: The ABO blood group system revisited: a review and update. *Immunohematology* 2009, **25**:48–59.
8. Patnaik SK, Holmberg W, Blumenfeld OO: BGMUT: NCBI db/BC database of allelic variations of genes encoding antigens of blood group systems. *Nucleic Acids Res* 2012, **40**(Database issue):D1023–D1029.
9. Franchini M, Liumbruno GM: ABO blood group: old dogma, new perspectives. *Clin Chem Lab Med* 2013, **51**:1545–1553.

10. Hakomori S. Antigen structure and genetic basis of histo-blood groups A, B and O: their changes associated with human cancer. *Biochim Biophys Acta* 1999, **147**:247-266.
11. Canuso C, Pizzarino G, Pucca A, Scapagnini G. "Positive biology": the centenarian lesson. *Immun Ageing* 2012, **9**:5.
12. Kolovou G, Barzilai N, Canuso C, Sikora E, Capri M, Tzanetakou IP, Kolovou H, Avery P, Kasiki N, Panotopoulos G, Franceschi C, Benetos A, Mikhailidis DP. The challenges in moving from ageing to successful longevity. *Curr Vasc Pharmacol* 2014, **12**:659-661.
13. Troen BR. The biology of aging. *Mt Sinai J Med* 2003, **70**:3-22.
14. Vasto S, Candore G, Balzirelli CR, Canuso C, Colonna-Romano G, Grimaldi MP, Listi F, Nuzzo D, Lio D, Canuso C. Inflammatory networks in ageing, age-related diseases and longevity. *Mech Ageing Dev* 2007, **128**:83-91.
15. Kirkwood TB. Understanding ageing from an evolutionary perspective. *J Intern Med* 2008, **263**:17-127.
16. Avery P, Barzilai N, Benetos A, Bilanou H, Capri M, Canuso C, Franceschi C, Kasiki N, Mikhailidis DP, Panotopoulos G, Sikora E, Tzanetakou IP, Kolovou H. Ageing, longevity, exceptional longevity and related genetic and non genetic markers: panel statement. *Curr Vasc Pharmacol* 2014, **12**:662-673.
17. Hayflick L. Entropy explains aging, genetic determinism explains longevity, and undefined terminology explains misunderstanding both. *PLoS Genet* 2007, **3**:e20.
18. López-Otin C, Blasco MA, Partridge L, Serrano M, Kroemer G. The hallmarks of aging. *Cell* 2013, **153**:1194-1217.
19. Capri M, Salvidi S, Monti D, Canuso C, Candore G, Vasto S, Oliveri F, Marchegiani F, Sansoni P, Baggio G, Marfì D, Pizzarino G, De Benedetti G, Franceschi C. Human longevity within an evolutionary perspective: the peculiar paradigm of a post-reproductive genetics. *Exp Gerontol* 2008, **43**:53-60.
20. Incalcaterra E, Accardi G, Balzirelli CR, Calmi G, Candore G, Canuso M, Canuso C. Pro-inflammatory genetic markers of atherosclerosis. *Curr Atheroscler Rep* 2013, **15**:329.
21. Balzirelli CR, Accardi G, Buffa S, Bulati M, Martorana A, Candore G, Colonna-Romano G, Lio D, Canuso C. Centenarian offspring: a model for understanding longevity. *Curr Vasc Pharmacol* 2014, **12**:718-725.
22. Balzirelli CR, Candore G, Accardi G, Bova M, Buffa S, Bulati M, Forte GJ, Listi F, Martorana A, Palmeri M, Pellicano M, Vaccarino L, Scola L, Lio D, Colonna-Romano G. Genetics of longevity. Data from the studies on Sicilian centenarians. *Immun Ageing* 2012, **9**:8.
23. Vasto S, Canuba G, Lio D, Colonna-Romano G, Di Bona D, Candore G, Canuso C. Inflammation, ageing and cancer. *Mech Ageing Dev* 2009, **130**:40-45.
24. Cevenini E, Canuso C, Candore G, Capri M, Nuzzo D, Duro G, Rizzo C, Colonna-Romano G, Lio D, Di Carlo D, Palmas MG, Scuri M, Pini E, Franceschi C, Vasto S. Age-related inflammation: the contribution of different organs, tissues and systems. How to face it for therapeutic approaches. *Curr Pharm Des* 2010, **16**:609-618.
25. Vasto S, Scapagnini G, Bulati M, Candore G, Castiglia L, Colonna-Romano G, Lio D, Nuzzo D, Pellicano M, Rizzo C, Ferrara N, Canuso C. Biomarkers of aging. *Front Biosci (Schol Ed)* 2010, **2**:392-402.
26. Canuso C, Candore G, Romano GC, Lio D, Bonafè M, Velardin S, Franceschi C. Immunogenetics of longevity. Is major histocompatibility complex polymorphism relevant to the control of human longevity? A review of literature data. *Mech Ageing Dev* 2001, **122**:445-462.
27. Canuso C, Candore G, Colonna-Romano G, Lio D, Bonafè M, Valerini S, Franceschi C. HLA, aging and longevity: a critical reappraisal. *Hum Immunol* 2000, **61**:942-949.
28. Listi F, Canuso C, Colonna-Romano G, Lio D, Nuzzo D, Candore G. HLA and KIR frequencies in Sicilian Centenarians. *Rejuvenation Res* 2010, **13**:314-318.
29. Roa IM, Maxwell LD, McVeran SE, Alexander HD, Curran MD, Middleton D, Ross OA. Killer Immunoglobulin-like Receptors (KIR) haplogroups A and B track with Natural Killer Cells and Cytokine Profile in Aged Subjects: Observations from Octo/Nonagenarians in the Belfast Bifely Longitudinal Free-living Aging Study (BFLFAST). *Immun Ageing* 2013, **10**:35.
30. Lumburo GM, Franchini M. Hemostasis, cancer, and ABO blood group: the most recent evidence of association. *J Thromb Thrombolysis* 2014, **38**:160-166.
31. Lumburo GM, Franchini M. Beyond immunohaematology: the role of the ABO blood group in human diseases. *Blood Transfus* 2013, **11**:401-409.
32. Rizzo C, Accardi G, Canuso C. Genetic variation in HLA and susceptibility to acute myeloid leukemia. *Acta Haematol* 2014, **133**:162-163.
33. Soranzo M, Blasco MA. Cancer and ageing: convergent and divergent mechanisms. *Nat Rev Mol Cell Biol* 2007, **8**:715-722.
34. Campisi J. Aging, cellular senescence and cancer. *Annu Rev Physiol* 2013, **75**:685-705.
35. Aird I, Lee DR, Roberts W. ABO blood groups and cancer of oesophagus, cancer of pancreas, and pituitary adenoma. *Br Med J* 1960, **1**:1163-1166.
36. Rizzato C, Kato I, Plummer M, Mulica N, Stein A, Jan van Doorn L, Franceschi S, Zanolin M. Risk of advanced gastric precancerous lesions in *Helicobacter pylori* infected subjects is influenced by ABO blood group and CagA status. *Int J Cancer* 2013, **133**:315-322.
37. Wolpin BI, Kraft P, Xu M, Stolpowski E, Olson ML, Ardan AA, Bueno-de-Mesquita HB, Gross M, Helzlsouer K, Jacobs EJ, LaCroix A, Pateran G, Stobenber-Solomon RZ, Zheng W, Albanes D, Allen NE, Arundodotir L, Austin MA, Boutron-Ruault MC, Buring JE, Carzian F, Chanock SJ, Gaziano JM, Giovannucci EL, Hallmans G, Hankinson SE, Hoover RN, Hunter DJ, Hutchinson A, Jacobs KB, et al. Variant ABO blood group alleles, secretor status, and risk of pancreatic cancer: results from the pancreatic cancer cohort consortium. *Cancer Epidemiol Biomarkers Prev* 2010, **19**:3140-3149.
38. Libby P, Ridker PM, Hansson GK. Progress and challenges in translating the biology of atherosclerosis. *Nature* 2011, **473**:317-325.
39. Libby P. Inflammation in atherosclerosis. *Arterioscler Thromb Vasc Biol* 2012, **32**:2045-2051.
40. Messer B, Bornhard D. Smoking and cardiovascular disease: mechanisms of endothelial dysfunction and early atherogenesis. *Arterioscler Thromb Vasc Biol* 2014, **34**:509-515.
41. Rader DJ, Hovingh GK. HDL and cardiovascular disease. *Lancet* 2014, **384**:618-625.
42. O'Donnell J, Laffan MA. The relationship between ABO histo-blood group, factor VII and von Willebrand factor. *Transfus Med* 2001, **11**:343-351.
43. Matsu T, Tani K, Mizuchi T. Structures of the asparagine linked oligosaccharide chains of human von Willebrand factor. Occurrence of blood group A, B, and H(O) structures. *J Biol Chem* 1992, **267**:8723-8731.
44. Soderst JM, Pizzo SV, McRee PA. Relationship of sialic acid to function and in vivo survival of human factor VII/von Willebrand factor protein. *J Biol Chem* 1977, **252**:5538-5546.
45. Paterson AD, Lopes-Wrella MF, Waggoner D, Boright AP, Hossain SM, Carter RE, Shen E, Mira L, Bharaj B, Sun L, Bull SB. Diabetes Control and Complications Trial/Epidemiology of Diabetes Interventions and Complications Research Group. Genome-wide association identifies the ABO blood group as a major locus associated with serum levels of soluble E-selectin. *Arterioscler Thromb Vasc Biol* 2009, **29**:1958-1967.
46. Kishi S, Park G, Berbalic M, Qi J, Dupuis L, Dehghan A, Be JC, Laiton RC, Xiao Q, Bonora E, Willett J, Xu Q, Witteman JC, Chazman D, Tracy RP, Balantyne CM, Ridker PM, Benjamin EJ, Ye S. Association of variation at the ABO locus with circulating levels of soluble intercellular adhesion molecule-1, soluble P-selectin, and soluble E-selectin: a meta-analysis. *Circ Cardiovasc Genet* 2011, **4**:681-686.
47. Maronneau S, Calteau Thomas A, Recher J, Le Moullec-Widje B, Ruvolet N, Clément M, Le Pendu J. ABH and Lewis histo-blood group antigens, a model for the meaning of oligosaccharide diversity in the face of a changing world. *Biochimie* 2001, **83**:65-73.
48. Fry AE, Griffiths MJ, Auburn S, Diakto M, Forton JT, Green A, Richardson A, Wilson J, Jilka W, Skayloof F, Pindar M, Pridu N, Williams TN, Marsh K, Molyneux ME, Taylor TE, Rockett KA, Kwiatkowski DP. Common variation in the ABO glycosyltransferase is associated with susceptibility to severe Plasmodium falciparum malaria. *Hum Mol Genet* 2008, **17**:567-576.
49. Murray S. ABO groups and Rh genotypes in the elderly. *Br Med J* 1961, **2**:1472-1474.
50. Sturgeon P, Beller S, Bates E. Study of blood group factors in longevity. *J Gerontol* 1963, **24**:90-94.
51. Shimizu K, Hirose N, Ebihara Y, Arai Y, Hamanatsu M, Nakazawa S, Maai Y, Inagaki H, Gondo Y, Fujimori I, Kanno Y, Konishi K, Kitagawa K. Blood type B might imply longevity. *Exp Gerontol* 2004, **39**:1563-1565.
52. Brocher ME, Hay SN. ABO blood type and longevity. *Am J Clin Pathol* 2011, **135**:96-98.
53. Vasto S, Canuso C, Castiglia L, Duro G, Monastero R, Rizzo C. Blood group does not appear to affect longevity: a pilot study in centenarians from Western Sicily. *Biogerontology* 2011, **12**:467-471.

54. Barbalic M, Dupuis L, Dehghan A, Be JC, Hoogeveen RC, Schnabel RB, Nambi V, Brofer M, Smith NL, Rotter A, Lu C, Tracy RP, Alekic N, Herriga J, Koza JF Jr, Rice K, Lip GY, Viscan RS, Gazier N, Larson MG, Utterlinden AG, Yamamoto J, Durda P, Hartunians T, Pasty BM, Boerwinkle E, Hofman A, Koenig W, Jonny NS, Witteman JC, et al. Large-scale genomic studies reveal central role of ABO in sP-selectin and dCAM-1 levels. *Hum Mol Genet* 2010, **19**:1863-1872.
55. Naitza S, Porcu E, Steri M, Taub DD, Mulas A, Xiao X, Strait J, Del M, Lai S, Busonero F, Maschio A, Usala G, Zdzienicka M, Sidore C, Zari I, Pittalis M, Loi A, Virdis F, Piras F, Deidda F, Whalen MB, Crisponi L, Concas A, Poddà C, Uzzau S, Scheet P, Longo DL, Lakatta E, Abecasis GR, Cao A, et al. A genome-wide association scan on the levels of markers of inflammation in Sardinians reveals associations that underpin its complex regulation. *PLoS Genet* 2012, **8**:e1002480.
56. Karakas M, Baumert J, Kliber ME, Thorand B, Dalmzier D, Sibermagel G, Grammer TB, Rottbauer W, Meisinger C, Illig T, März W, Koenig W. A variant in ABO gene explains the variation in soluble E-Selectin levels - Results from dense genotyping in two independent populations. *PLoS One* 2012, **7**:e51441.
57. Casuso C, Accard G, Vitruo C, Candore G. Sex, gender and immunosenescence: a key to understand the different lifespan between men and women? *Immun Ageing* 2013, **16**:10.

doi:10.1186/1745-4933-11-16

Cite this article as: Rizzo et al.: Possible role of ABO system in age-related diseases and longevity: a narrative review. *Immunity & Ageing* 2014 **11**:16.

Submit your next manuscript to BioMed Central and take full advantage of:

- Convenient online submission
- Thorough peer review
- No space constraints or color figure charges
- Immediate publication on acceptance
- Inclusion in PubMed, CAS, Scopus and Google Scholar
- Research which is freely available for redistribution

Submit your manuscript at  
[www.biomedcentral.com/submit](http://www.biomedcentral.com/submit)



## **6. Weak D and partial D: our experience in daily activity**

## Weak D and partial D: our experience in daily activity

Claudia Rizzo<sup>1,2</sup>, Laura Castiglia<sup>1,2</sup>, Emma Arena<sup>2</sup>, Simona Gangi<sup>1,2</sup>, Giuseppina Mazzola<sup>2</sup>, Calogero Caruso<sup>1,2</sup>, Sonya Vasto<sup>1,2</sup>

<sup>1</sup>Department of Medical and Forensic Pathology and Biotechnologies, University of Palermo, Palermo; <sup>2</sup>Unit of Immunohaematology and Transfusion Medicine, "Paolo Giaccone" University Hospital, Palermo, Italy

Dear Sir,

The *RH* genes *RHD* and *RHCE* encode two proteins that represent the clinically most important blood group system defined by the sequences of red cell membrane proteins. *RHD* and *RHCE*, encoding the Rh proteins (D and Cc/Ee, respectively), are organised in tandem on chromosome 1p34-p36 and probably derived from duplication of a common ancestral gene. Many *RH* genes carry point mutations, or have rearrangements and exchanges between *RHD* and *RHCE* which result from gene conversion events. *RHCE* encode hybrid proteins that have RhCE-specific amino acids in RhD, or RhD-specific residues in RhCE. These might generate new antigens in the Rh blood group system, and alter or weaken expression of the conventional antigens<sup>1,2</sup>.

Reduced expression of D antigen occurs in an estimated 0.2%-1% of Caucasians. Historically, red blood cell antigens that react with anti-D only after extended testing with the indirect antiglobulin test are called weak D. Weak D expression primarily results from single point mutations in *RHD* which encode amino acid changes predicted to be intracellular or in the transmembrane regions of RhD. These affect the efficiency of insertion, and, therefore, the quantity of RhD protein in the membrane, reflected in the reduced number of D antigen sites on the red blood cells. Red blood cells with partial D antigen type as D-positive, but individuals often produce anti-D when stimulated by transfusion or pregnancy. Some partial D, similar to weak D, result from point mutations in *RHD* that cause single amino acid changes. But, in contrast to weak D, these changes are located on the extracellular regions and alter or create new epitopes<sup>1,2</sup>.

Molecular methods for blood group genotyping became available more than 10 years ago and are useful methods to help to clarify immunogenetic doubts or to verify results<sup>3</sup>. Molecular *RHD* blood group typing is very efficient for managing donors

and patients carrying any of the various molecular types of weak D and partial D. Weak D and partial D expression are caused by a large number of *RHD* alleles and variations of the antigen structure of RhD result either in a partial (partial D) or a weak D phenotype (weak D). Weak and partial D result in quantitative and qualitative changes in Rh protein expression respectively. The clinical relevance of these changes are, according to Flegel<sup>1,2</sup>, that weak D subjects belonging to weak type 1, 2, 3, 4.0, 4.1 and 5 can be treated as Rh-positive and be transfused by Rh-positive red blood cells, while subjects with weak type 4.2-11 and 15 should be treated as Rh-negative and transfused with Rh-negative red blood cells. Partial D can produce different protein epitope expression and, therefore, induce specific antibody production. In this situation, partial D subjects should be considered Rh-negative and transfused with Rh-negative red blood cells<sup>1,2</sup>.

In our daily practice, D antigens are determined serological agglutination tests according to the guidelines of Italian Society for Transfusion Medicine and Immunohaematology<sup>4</sup>. In particular, during routine Rhesus tests, a microtitre plate-based assay employing two different anti-D (D-Rapid, clone RUM-1 IgM and D-Fast, clone IgM; Immucor Gamma, Immucor, Inc. Norcross, GA, USA) is used. Thereafter, the D negative samples are tested for D<sup>a</sup> with two different methods: a microtitre plate employing Anti-D Duo IgG-IgM (clone IgG-IgM clone Th28+MS26; Galileo Capture R. ImmucorGamma) using solid phase capture and a gel matrix test employing one anti-D (Id-Dia Clone Anti-D; DiaMed GmbH, Switzerland). If the result is positive, the samples are tested with a gel matrix direct antiglobulin assay. The serological analysis for allelic D variant is based on "Partial Rh Typing" (ImmucorGamma) using six monoclonal IgG antisera and Capture-R. Select (ImmucorGamma) in a solid phase method.



Molecular biology analysis is performed using commercial kits from BAGene Health Care GmbH (Weak D-TYPE; Partial D-TYPE; BAG Health Care GmbH, Germany). The basic material for typing with BAGene DNA-SSP kits is purified DNA from peripheral blood mononuclear cells. The test is based on sequence-specific primers (SSP) - polymerase chain reaction (PCR). BAGene Partial D-TYPE allows for the molecular genetic determination of partial D such as *DII*, *DIII*, *DIV*, *DV*, *DVI*, *DVII*, *DAU*, *DBT*, *DFR*, *DHM*, *DHMii*, *DNB* and *DHAR* (Rh33)<sup>6</sup>, whereas BAGene Weak D-TYPE allows the molecular genetic determination of weak D types including *1*, *2*, *3*, *4.0/4.1*, *4.2*, *5*, *11*, *15* and *17*<sup>6</sup>. Both methods are based on the fact that primer extension, and hence successful PCR, relies on an exact match at the 3'-end of both primers. Therefore, only if the primers entirely match the target sequence is amplification obtained; this is subsequently visualised by agarose gel electrophoresis.

In 2010, a survey performed at our Unit, the Immunohaematology and Transfusion Medicine Unit of the "Paolo Giaccone" University Hospital in Palermo, revealed that out of 11 samples (from 8 males and 3 females) analysed and regarded by preliminary analysis as weak D, only eight were confirmed by complete serological analysis as weak D, whereas the other three samples did not give satisfactory results. A genetic protocol was, therefore, used, which gave the results of D weak type 1/DCS, type 11/DCS, and 5/DAR respectively. On the basis of this outcome, we re-evaluated the eight patients assessed as weak D by serological analysis getting D weak type 5/DCS as the most frequent result. These results were not influenced by the patients' gender or age.

Given the strong immunogenicity of the D antigen and the high rate of immunisation of D-negative individuals after the transfusion of D-positive red blood cells, the determination of *RHD* alleles is of special significance<sup>1,2,5</sup>. Immunisation of D-negative individuals can occur following transfusions of D-positive red blood cells and in D-negative pregnant women carrying D-positive fetuses<sup>5</sup>. The aim of this study was to use a genetic protocol to confirm and/or clarify D antigen doubts in order to prevent immunisation of patients. At first glance, serological analysis for D weak appeared to be

trustworthy regarding common D weak phenotypes whereas analysis of non-common phenotypes was less satisfactory. In particular, D weak type 5 was easily identifiable by serological analysis whereas D weak types 1 and 11 seemed to display lower antibody affinity and was, therefore, less well identified. With respect to this problem, the use of the genetic protocol was decisive for obtaining correct results. The evidence of D partial results was confirmed by the presence of DCS and DAR variants. The genetic resolution of these variants is, so far, limited, and these two results are, therefore, taken in the context of D-positive results. However, given the low number of samples screened, this study cannot be decisive and other samples need to be analysed.

#### Acknowledgments

Claudia Rizzo is PhD student at the Molecular Medicine PhD course (directed by Calogero Caruso) at Palermo University and this work is submitted in partial fulfilment of the requirement for her PhD degree.

*The Authors declare no conflicts of interest.*

#### References

- 1) Flegel WA. Blood group genotyping in Germany. *Transfusion* 2007; **47**: 475-535.
- 2) Flegel WA. Molecular genetics and clinical applications for RH. *Transfus Apher Sci* 2011; **44**: 81-91.
- 3) Daniels G. The molecular genetics of blood group polymorphism. *Hum Genet* 2009; **126**: 729-42.
- 4) Grazzini G, Alfano G, Gandini G et al. *Standard di Medicina Trasfusionale 1<sup>a</sup> ed.* Edizioni SIMTI; 2007. Available at: [http://www.simti.it/linee\\_guida](http://www.simti.it/linee_guida). Last accessed on 13/06/2011.
- 5) Krumpel B. Are weak D RBCs really immunogenic? *Transfusion* 2006; **46**: 1061-6.

Arrived: 13 June 2011 - Revision accepted: 23 August 2011

Correspondence: Calogero Caruso

U.O. di Immunohaematologia e Medicina Trasfusionale  
Dipartimento di Biopatologia e Biotecnologie Mediche e Forensi  
Polisclinico Universitario "Paolo Giaccone"

Università di Palermo  
Via del Vespigo  
96100 Palermo, Italy  
e-mail: [marco@unipa.it](mailto:marco@unipa.it)



## **7. Genetic Variation in Human Leukocyte Antigen and Susceptibility to Acute Myeloid Leukemia**

## Genetic Variation in Human Leukocyte Antigen and Susceptibility to Acute Myeloid Leukemia

Claudia Rizzo<sup>a,b</sup> Giulia Accardi<sup>b</sup> Calogero Caruso<sup>a,b</sup>

<sup>a</sup>Unit of Transfusion Medicine, University Hospital, and <sup>b</sup>Department of Pathobiology and Medical and Forensic Biotechnologies, University of Palermo, Palermo, Italy

### © Free Author Copy – for personal use only

ANY DISTRIBUTION OF THIS ARTICLE WITHOUT WRITTEN CONSENT FROM S. KARGER AG, BASEL IS A VIOLATION OF THE COPYRIGHT.

Written permission to distribute the PDF will be granted against payment of a permission fee, which is based on the number of accesses required. Please contact [permission@karger.ch](mailto:permission@karger.ch)

In this issue of *Acta Haematologica*, the authors report the association between the human major histocompatibility complex (MHC) human leukocyte antigen (HLA)-C3 and acute myeloid leukemia in the Korean population, confirming previous studies on the association between HLA-C and acute myeloid leukemia [1]. Following the demonstration by Lilly et al. [2] in 1964 of the increased risk of spontaneous or virus-induced leukemia in congenic mice with the H-2K (the MHC in mice), it is now over 40 years since the first associations between particular HLAs and leukemia and lymphoma diseases were described. These include a cross-reactive group of HLA-B and Hodgkin's disease, HLA-A2 and acute lymphocytic leukemia (ALL) [3]. Over time, many studies on the association between HLA and the different kinds of leukemia have been performed showing contrasting results [3]. Following these pioneering studies, a broad spectrum of immune-mediated diseases, certain malignancies, longevity, infectious diseases, and adverse reactions to some drugs have been shown to be associated with allelic variants of HLA [4, 5]. So far, there appear to be no striking leukemia genetic susceptibility loci in HLA similar in nature and magnitude to those seen for autoimmune and infectious diseases. However, mounting evidence suggests that more modestly associated susceptibility loci

showing population and type may exist [1, 3]. Nevertheless, the clear identification of a causative role for the HLA polymorphism in the pathogenesis of HLA-associated leukemia remains the exception rather than the rule. Advances in the understanding of MHC biological functions will enable comprehensive and definitive studies for evaluating the role of HLA in leukemia.

The human MHC is a multigene which includes the highly polymorphic HLA class I (HLA-A, -B and -C) and class II genes (HLA-DRA, HLA-DRB1, HLA-DRB3–5, HLA-DQA, HLA-DQB, HLA-DPA and HLA-DPB) that code different kinds of glycoproteins specialized in the presentation of short peptides derived from infectious agents or self-proteins to T lymphocytes, hence playing a key role in both cellular and humoral immune response. This occurs via signaling to T cell receptors and the subsequent initiation of the acquired immune response. Their polymorphism impacts on the peptide-binding groove, varying the amino acids that can be housed within the peptide-binding pockets. Thus, different HLA alleles possess different peptide-binding repertoires. HLA class I proteins present peptides from intracellular pro-

C.R. is a PhD student of the PhD course directed by C.C.

KARGER 125

E-Mail [karger@karger.com](mailto:karger@karger.com)  
[www.karger.com/aha](http://www.karger.com/aha)

© 2014 S. Karger AG, Basel  
0001-5792/14/1332-0162\$39.50/0

Prof. Calogero Caruso, MD  
Dipartimento di Biopatologia e Biotecnologie Mediche e Forensi  
Sezione di Patologia Generale  
Corso Tukory 211, IT-90134 Palermo (Italy)  
E-Mail [calogero.caruso@unipa.it](mailto:calogero.caruso@unipa.it)

teins (including invasive viruses) to T cell receptors on CD8 (cytotoxic) T cells leading to immune mechanisms which destroy the cell. It is noteworthy that HLA proteins, in particular HLA-C alleles, also interact with killer immunoglobulin-like receptors (KIR) that play a crucial role in the activity of natural killer cells, known to control tumor transformation and viral infection. The peptide-binding groove of HLA class II proteins, only expressed on antigen-presenting cells, carries a self- or nonself-peptide derived from proteins sourced from outside the cell by endocytosis. It is then presented to the T cell receptor of CD4 (helper) T cells. Besides, there is a wide variety of extended HLA genes, some with a role in immunity, some with nonimmune roles and many with unidentified roles. The simultaneous occurrence of two or more alleles at a frequency other than expected by chance is termed allelic association or linkage disequilibrium, and there is strong linkage disequilibrium between several of the extended HLA loci [4, 6].

Taking the complexity and function of HLA into account, which are the mechanisms responsible for an association between leukemia and HLA, if any? Most of the performed studies present serious challenges because of a number of confounding factors. Firstly, sample size is important, as most studies are prone to selection bias and false-positive associations. In fact, a minimum of 320 subjects for each sample is required to detect the difference in frequency if an antigen occurs, for example, in 5% of sample A and in 15% of sample B. Secondly, different studies have different inclusion criteria, inappropriate mixing of data (cohort effects) referring to people of different ages and inappropriate matching of controls, i.e. a lack of selection from the same target population. Thirdly, in several studies, correction to adjust for multiple

comparisons is not used (we do not need them only in confirmatory studies). Lastly, the associated HLA polymorphism may play no direct role, with the actual disease-predisposing polymorphism being in linkage disequilibrium with the initially reported HLA association (which merely acts as a marker) [5].

With regard to the possible role of HLA molecules in leukemia, a causative role of HLA in terms of presentation of a nonself-peptide (i.e. virus) or altered self-peptide (i.e. a mutated oncogene) is a possibility. An alternative, not mutually exclusive, possibility refers to a causative role via the influence on the T cell repertoire, including Treg cells [3, 4]. On the other hand, no significant evidence exists for the association with non-HLA loci in extended MHC [1, 3].

It is noteworthy that a recent in-depth investigation of KIR genes and their cognate HLA ligands on childhood ALL risk, which was carried out in 212 childhood ALL cases and 231 healthy controls, suggested a role for KIR genes and their HLA ligands in childhood ALL etiology that may vary among ethnic groups [7].

So, in our opinion, the observed association of HLA class I antigen in particular with HLA-C alleles can be explained by their role as ligands for KIR. The negative results obtained might be due to the fact that the HLA-C gene is highly polymorphic and more than 1,000 different proteins have been identified so far, so a 2-digit HLA-C typing is not accurate enough to predict which KIR/KIR ligand interaction occurs. In addition, HLA-C-bound peptides play a role in KIR/KIR ligand interactions, as not all the presented peptides seem to permit KIR interaction [6].

In future studies, the accurate characterization of HLA-C allotypes will be crucial to clarify this point.

## References

- 1 Yoon J: Acute myeloid leukemia is a disease associated with HLA-C3. *Acta Haematol* 2015;133:164-167.
- 2 Lilly F, Boyse EA, Old LJ: Genetic basis of susceptibility to viral leukaemogenesis. *Lancet* 1964;2:1207-1209.
- 3 Urayama KY, Thompson PD, Taylor M, Trachtenberg EA, Chokkalingam AP: Genetic variation in the extended major histocompatibility complex and susceptibility to childhood acute lymphoblastic leukemia: a review of the evidence. *Front Oncol* 2013;3:300.
- 4 Dyer P, McGilvray R, Robertson V, Turner D: Status report from 'double agent HLA': health and disease. *Mol Immunol* 2013;55:2-7.
- 5 Caruso C, Candore G, Romano GC, Lio D, Bonafè M, Valensin S, Franceschi C: Immunogenetics of longevity. Is major histocompatibility complex polymorphism relevant to the control of human longevity? A review of literature data. *Mech Ageing Dev* 2001;122:445-462.
- 6 Falco M, Moretta L, Moretta A, Bottino C: KIR and KIR ligand polymorphism: a new area for clinical applications? *Tissue Antigens* 2013;82:363-373.
- 7 de Smith AJ, Walsh KM, Ladner MB, Zhang S, Xiao C, Cohen F, Moore TB, Chokkalingam AP, Metayer C, Buffer PA, Trachtenberg EA, Wiemels JL: The role of KIR genes and their cognate HLA class I ligands in childhood acute lymphoblastic leukemia. *Blood* 2014; 123:2497-2503.

## © Free Author Copy – for personal use only

ANY DISTRIBUTION OF THIS ARTICLE WITHOUT WRITTEN CONSENT FROM S. KARGER AG, BASEL IS A VIOLATION OF THE COPYRIGHT.

Written permission to distribute the PDF will be granted against payment of a permission fee, which is based on the number of accesses required. Please contact [permission@karger.ch](mailto:permission@karger.ch)

## 8. DISCUSSION AND CONCLUSION

This thesis highlights the importance of applying the scientific molecular method to transfusion medicine.

It has been demonstrated that the history of transfusion medicine, was born with the need of man to cure incurable diseases and has legendary and controversial origins.

The first approaches to blood for therapeutic purposes were very different from we intend for "transfusion therapy": the blood was like a magic fluid capable of healing the wounds of soul before than body. So history shows that the first transfusion (made with oral administration) served to rejuvenate or to treat mental illness. In the Middle Ages bloodletting therapy was frequently used for release negative moods responsible of disease

The beneficial and adverse effects generated a very painful story regard the use of blood for therapeutic purposes.

The Renaissance, a time of important discoveries in medicine, is characterized by great contrasts. On the one hand, the growing scientific interest initiating the "experimental period"; the other the collection of data, among confirmations and denials, creates a general climate of distrust and doubts regarding the transfusion only heterologous and performed with primordial instruments (vein to vein) at that time.

So, in Europe transfusions were not practiced throughout the XVIII century.

The scientific discoveries of the XIX century and the need to treat the wounded in the First World War, gave great revival to the transfusion medicine and started the "Therapeutic period" that continues until the present day.

Currently, transfusion medicine is open to many clinical fronts and has a great interest in the continuous innovations for transfusion therapy improvement.

How might continued innovation contribute to improved transfusion therapy? According to M. Schilling ( professor of management and organizations at New York

University Stern School of Business) there are at least five approaches (*table 5*). (*Schilling 2012*)

TYPES OF INNOVATION	
1.	Improving products
2.	Improving process to produce a product
3.	Improve uses of existing products
4.	Identifying new uses of existing products
5.	Use existing processes to produce new products

*Table 5.* Typing of technical innovation and strategic managements. (*Schilling MA*)

*1) Improving products.* Recent examples of this approach in transfusion medicine are RBC additive solutions that extend storage; the introduction of leukoreduction for TRALI preventions; the introduction of pathogen inactivation of labile blood components (PLTs). Pathogen inactivation can be done with a psoralen-type compound that prevents DNA strands from replicating, or riboflavin and UV light that damages nucleic acids. Blood products treated with these methods are widely used and clinically effective. A fringe benefit of the pathogen inactivation techniques is that they prevent replication of lymphocytes and thus eliminate the need for irradiating blood products. (*McCullough 2007; Schlenke 2014*)

*2) Improving process to produce a product.* In this case, aphaeresis plays a key role. The multicomponent production with aphaeresis introduced in the last decades, has allowed to improve the quality of the product (blood components) through the improvement of the production process. For example, there are simple devices now that are used to collect 2 units of RBCs from a single donor. Even more exciting is that these devices can be used to collect other combinations of components. Continued innovation by engineers can be expected to refine these devices to make it possible to collect any combination of components from each specific donor at the collection site.

This improves the standards of the product and reduces handling laboratory, producing blood components with more quality and safety. Once that is possible the component laboratory may have outlived its usefulness. (Snyder et al 2003)

3) Improved uses of existing products. A goal of modern transfusion medicine is to improve the appropriateness of prescribing blood components. This comes from awareness that a blood component, if is not necessary, can expose the recipient to the transfusion risks and the improper use reduces availability for other patients. So, have been carefully studied and declared the indications to transfusion therapy. Examples of this area are the evolution of the prophylactic PLT transfusion trigger to  $10 \times 10^9/L$  or the lowered RBC transfusion trigger to 8 or 7g/dL, PLT crossmatching, and blood management programs (McCullough 2010).

4) Identifying new uses of existing products. One of the challenges of transfusion research, is to know more precisely the properties of blood and its components. This has allowed to understand that platelets, for example, are not only protagonists of homeostasis, but platelet's granules contain growth factors able to stimulate tissue regeneration. So, the platelets can also be used for other purposes (regenerative medicine). Another eexamples is the use of IVIg in various autoimmune diseases and the use of plasma for replacement in exchange transfusions to treat thrombotic thrombocytopenic purpura (TTP): the use of plasma in the treatment of TTP has radically changed the natural history of the disease and improved the prognosis and life expectancy of patients.

5) Use existing processes to produce new products. Novel cellular therapies or cord blood banking are examples of this type of innovation. The cord blood collection procedure is different from whole blood or apheresis collections, but the issues in cord blood banking are essentially the same for whole blood or apheresis. These issues include consent, medical evaluation of the donor, collection procedures, cell preservation, testing for safety and potency, and transfusion techniques. (Broxmeyer 2013)

A large number of different novel cellular products are either being manufactured or under development. For instance, with the use of cell manipulation techniques it is possible to produce cytomegalovirus (CMV) cytotoxic T cells for treatment of CMV infection, CD4/25 regulatory T lymphocytes for prevention of GVHD, isolation of marrow cells for cardiac repair after myocardial infarction, T cells for the treatment of prostatic carcinoma, cytotoxic T lymphocytes to treat nasopharyngeal carcinoma due to EBV infection, T-depleted blood stem cell grafts to enhance engraftment, mesenchymal stem cells to treat sickle cell disease, autologous stem cells to repair small vessels in the legs to treat leg intermittent claudication, and cardiac stem cells for repair after myocardial infarction<sup>2</sup>.(Redd et al 2009)

This thesis and the work performed during this PhD course highlight another aspect that contributes to transfusion therapy innovation: the *improving of the molecular technologies application*.

This has important significance not only for the diagnosis of disease, but also in the identification of a targeted and personalized transfusion therapy.

For example, molecular cloning and characterization of ADAMTS13 gene and protein structure have opened a new avenue for study of the biology and biochemistry of the ADAMTS13 protease. Development of a sensitive and specific assay for ADAMTS13 activity and inhibitor would not only help to understand the pathogenesis of TTP, but also to facilitate a more timely and accurate clinical diagnosis, which is crucial for initiating and tailoring therapy in patients with TTP.

The knowledge of the ADAMTS13 gene, have provided further insight into the structure-function relationships, biosynthesis, and regulation of the ADAMTS13 protease. To date, more than 70 mutations on ADAMTS13 gene have been described in patients with congenital or familial TTP. The majority of these mutations are

---

<sup>2</sup> Examples of products being developed manufacture through the National Heart, Lung, and Blood Institute (NHLBI)-funded group called Production Assistance for Cellular Therapies (PACT)

missense mutations involving cysteine residues and have been identified in patients with severe deficiency of plasma ADAMTS 13. So, the mutations on ADAMTS13 gene has been considered to be the primary cause of congenital TTP.(*Shelat et al 2005*)

The presence of ADAMTS13 autoantibodies are rather specific for making a diagnosis of acquired TTP. In addition, a high titer of inhibitory autoantibodies correlates with more relapses (*Tsai et al 1998*). An ELISA assay along with Western blotting using the recombinant ADAMTS13 as an antigen has been developed recently, which can detect both inhibitory and non inhibitory autoantibodies. (*Reiger et al 2005*)

Adjunct immune therapies such as rituximab, an anti-CD20 chimeric monoclonal antibody, or cyclophosphamide, may be considered to reduce inhibitory antibodies in patients with acute TTP who do not adequately respond to plasma exchange or are chronically relapsed (*Fakhouri et al 2004*). Therefore, a robust ADAMTS13 inhibitor assay is critical for understanding of the mechanism of TTP and for tailoring therapy.

Another example is the study of the growth factors (GFs) used for tissue repair in regenerative medicine. Our study on the application of platelet gel in orthopedics, have demonstrated the potential to modify the natural healing pathway of tendons and ligaments in several ways. The action is related to the increased concentration of GFs and bioactive proteins released by activated platelets (*Table 6*), which seem able to help the regeneration of tissues that otherwise have low healing potential, potentially restoring biomechanical properties similar to normal tendons and ligaments (*Taylor et al 2011*).



<b>GF</b>	<b>Function</b>
TGF- $\beta$ 1	Matrix synthesis
PDGF	Stimulate angiogenesis, cell proliferation, mitogen for fibroblasts
bFGF	Proliferation of fibroblasts and myoblasts, angiogenesis
VEGF	Angiogenesis
EGF	Proliferation of epithelial and mesenchymal cells
IGF-1	Stimulate fibroblasts and myoblasts
HGF	Angiogenesis

bFGF, basic fibroblast growth factor; HGF, hepatocyte growth factor; IGF-1, insulin-like growth factor; PDGF, platelet-derived growth factor; TGF, transforming growth factor.

Table 6. GFs Released by Activated Platelets (*Taylor et al 2011*)

The application of PRP amplifies the surge of chemical mediators to the microenvironment of the injured area, including platelet derived factors. The increased concentration of platelets and GFs mimics the initial stage of the inflammatory response, characterized by the migration of neutrophils, monocytes, and macrophages to the site of injury under the guidance of the chemical mediators.

These cytokines mediate the initiation of neovascularization, tenocyte proliferation, fibroblast proliferation, and further recruitment of inflammatory cells. In addition to the stimulatory effects of PRP on reparative cells, there is evidence that PRP may also have an inhibitory effect on certain pro-inflammatory cytokines that may be detrimental to the early stages of healing, specifically through suppression of IL-1 release from activated macrophages. This dual action of enhancing repair and minimizing tissue breakdown may allow local PRP application to accelerate the tissue healing process, leading to a wide range of potential applications and potential advantages for improved outcomes and faster recovery.<sup>11</sup>

Finally, an improvement in the application of molecular techniques, concerns the blood and HLA typing. Our data, underlined the importance of molecular biology in Immunohematology to discriminate aspects not easily identified by serology.

Today the blood banks of rare groups use of the latest generation molecular biology techniques (microarray and array) to type in extended erythrocyte antigens.

Yet little explored is the genetic study of erythrocyte alloreactivity.

Alloreactivity is the production of alloantibodies (antibodies against erythrocyte antigens belonging to the minor blood groups) as a result of antigenic transfusion stimulus. The literature about alloreactivity, correlates to a precise set-HLA class II, which emphasizes the increased susceptibility of individuals to produce alloantibodies in the presence of the same antigenic stimulus (*Gragert 2014*).

Therefore, our future prospects are oriented in a case-control study to evaluate serologically alloreactive subjects polytransfused (case) and not transfused (control) in order to correlate the HLA and immune response.

Concluding, innovation in blood banking and transfusion medicine can be also considered based on the underlying science and technology or the organizations that fostered innovation.

For continued innovation, transfusion medicine and blood banking must imbue a culture in which embrace the new and appreciate the value of innovation not just for a financial return on investment, but to improve medical care and provide value to patients.

The transfusion community must be forward looking and open to new ways of doing things. A commitment from blood organizations to innovation will be essential: clinical trial sites and organizations willing to evaluate and support these innovations, as a driving stimulus is dedication to continue to improve transfusion therapy for patients.

During the past several decades, remarkable advances have led to improved transfusion therapy for patients. For continued innovation, it will be important to strengthen relationships with other scientific and technical disciplines and to attract talented young people into this field.

## REFERENCES

---

Aird I, Bentall HH, Roberts JA (1953) A relationship between cancer of stomach and the ABO blood groups. *Br Med J* 1:799–801

Ansart-Pirenne H, Asso-Bonnet M, Le Pennec P-Y, Roussel M, Patereau C, Noizat-Pirenne F. RHD variants in whites: consequences for checking clinically relevant alleles. *Transfusion* 2004;44(9):1282–1286.

Avent ND. Large-scale blood group genotyping: clinical implications. *Br.J.Haematol* 2009 Jan;144(1):3–13.

Bikfalvi A. Recent developments in the inhibition of angiogenesis: examples from studies on platelet factor-4 and the VEGF/VEGFR system. *Biochem Pharmacol.* 2004 15;68(6):1017-21.

Blancher A, Apoil PA. Evolution of RH genes in hominoids: characterization of a gorilla RHCElike gene. *J.Hered* 2000 May;91(3):205–210.

Boulton FE. Blood transfusion; additional historical aspects. Part 1. The birth of transfusion immunology. *Transfus Med.* 2013 Dec;23(6):375-81

Boulton FE. Blood transfusion; additional historical aspects. Part 2. The introduction of chemical anticoagulants; trials of 'Phosphate of soda'. *Transfus Med.* 2013 Dec;23(6):382-8.

Broxmeyer HE, Farag S Background and future considerations for human cord blood hematopoietic cell transplantation, including economic concerns. *Stem Cells Dev.* 2013 Dec;22 Suppl 1:103-10

Bruserud O, Tvedt TH, Paulsen PQ, Ahmed AB, Gedde-Dahl T, Tjønnfjord GE, Slåstad H, Heldal D, Reikvam H. Extracorporeal photopheresis (photochemotherapy) in the treatment of acute and chronic graft versus host disease: immunological mechanisms and the results from clinical studies. *Cancer Immunol Immunother.* 2014 Aug;63(8):757-77.

Byrne DJ, Hardy J, Wood RA. et al. Effect of fibrin glues on the medical properties for healing wounds. *Br J Surg* 1991;78: 841-3.

Carritt B, Blunt T, Avent N, Daniels G, Steers F. Rh null phenotypes are not due to a gross deletion and can occur on different Rh genetic backgrounds. *Ann.Hum.Genet* 1993 Oct;57(Pt 4):273–279.

Cartron JP, Colin Y. Structural and functional diversity of blood group antigens. *Transfus.Clin.Biol* 2001;8(3):163–199.

Champion RH, Burton JL, BurnsAD, et al. *Textbook of Dermatology*. 6th ed. Oxford, 1998 Blackwell.

Coppola G. Il gel piastrinico nel trattamento delle ulcere diabetiche. ABS 3 Corso di aggiornamento “La riparazione tessutale delle ulcere cutanee croniche” Campolongo-Ottobre 2004

Daniels GL, Faas BH, Green CA, Smart E, Maaskant-van Wijk PA, Avent ND, Zondervan HA, von dem Borne AE, van der Schoot CE. The VS and V blood group polymorphisms in Africans: a serologic and molecular analysis. *Transfusion* 1998;38(10):951–958.

Daniels, GL. *Human Blood Groups*. 2 ed.. Oxford: Blackwell Science; 2002.

Denomme GA, Flegel WA. Applying molecular immunohematology discoveries to standards of practice in blood banks: now is the time. *Transfusion* 2008 Nov;48(11):2461–2475

Durand C., Dzierzak E., Embryonic beginnings of adult hematopoietic stem cells. *Hematologica* 2005; 90:100-108.

Fakhouri F, Teixeira L, Delarue R, et al. Responsiveness of thrombotic thrombocytopenic purpura to rituximab and cyclophosphamide. *Ann Intern Med* 2004;140:314–315

Flegel WA. ABO genotyping: the quest for clinical applications. *Blood Transfus.* 2013 Jan;11(1):6-9.

Flegel WA. Homing in on D antigen immunogenicity. *Transfusion* 2005 Apr;45(4):466–468

Flegel. Molecular genetics and clinical applications for RH *Transfus Apher Sci.* 2011 February; 44(1): 81–91

Fрати P, Montanari Vergallo G, Di Luca NM. La trasfusione di sangue: storia, etica e diritto. *Journal of History of Medicine- MEDICINA NEI SECOLI ARTE E SCIENZA*, 17/3 (2005) 769-802

Gallagher KA, Liu ZJ, Xiao M, Chen H, Goldstein LJ, Buerk DG, Nedeau A, Thom SR, Velazquez OC. Diabetic impairments in NO-mediated endothelial progenitor cell mobilization and homing are reversed by hyperoxia and SDF-1 alpha. *J Clin Invest*. 2007; 117(5):1249-59.

Gane P, Le Van Kim C, Bony V, El Nemer W, Mouro I, Nicolas V, Colin Y, Cartron JP. Flowcytometric analysis of the association between blood group-related proteins and the detergentinsoluble material of K562 cells and erythroid precursors. *Br.J.Haematol* 2001 Jun;113(3):680–688.

Gragert L, Fingerson S, Albrecht M, Maiers M, Kalaycio M, Hill BT. Fine-mapping of HLA associations with chronic lymphocytic leukemia in US populations. *Blood*. 2014 Oct 23;124(17):2657-65.

Hasekura Wagner FF, Frohmajer A, Flegel WA. RHD positive haplotypes in D negative Europeans. *BMC Genet* 2001;2(1):10.

Hillyer CD, Shaz BH, Winkler AM, Reid M. Integrating molecular technologies for red blood cell typing and compatibility testing into blood centers and transfusion services. *Transfus.Med.Rev* 2008 Apr;22(2):117–132.

Holloway GA, Steed DL, De Marco MJ, et al. A randomized, controlled, multicenter, dose response trial of activated platelet supernatant, topical CT-102 in chronic, nonhealing, diabetic wounds. *Wounds* 1993; 5: 198-206

Jansen J., Hanks S., Thompson J.M., Dugan M.J., Akard L.P., Transplantation of hematopoietic stem cells from the peripheral blood. *J. Cell. Mol. Med*. 2005; 9:37-50.  
Jiménez B, Volpert OV, Crawford SE, Febbraio M, Silverstein RL, Bouck N. Signals leading to apoptosis-dependent inhibition of neovascularization by thrombospondin-1. *Nat Med*. 2000; 6(1):41-8.

Kardaş F, Cetin A, Solmaz M, Büyükoğlan R, Kaynar L, Kendirci M, Eser B, Unal A Successful treatment of homozygous familial hypercholesterolemia using cascade filtration plasmapheresis. *Turk J Haematol*. 2012 Dec; 29(4):334-41

Kato-Yamazaki MTournamille C, Meunier-Costes N, Costes B, Martret J, Barrault A, Gauthier P, Galacteros F, Nzouekou R, Bierling P, Noizat-Pirenne F. Partial C antigen

in sickle cell disease patients: clinical relevance and prevention of alloimmunization. *Transfusion* 2010 Jan;50(1):13–19.

Kaufmann S.. Immunology's foundation: the 100-year anniversary of the Nobel Prize to Paul Ehrlich and Elie Metchnikoff. *Nature Immunology*; 2008, 7(9): 705-12

Kisucka J, Butterfield CE, Duda DG, Eichenberger SC, Saffaripour S, Ware J, Ruggeri ZM, Jain RK, Folkman J, Wagner DD. Platelets and platelet adhesion support angiogenesis while preventing excessive hemorrhage. *Proc Natl Acad Sci U S A*. 2006, 24;103(4):855-60.

Knighton DR, Ciresi K, Fiegel VD, et al. Stimulation of repair in chronic, nonhealing, cutaneous ulcers using platelet-derived wound healing formula. *Surg Gynecol Obstet* 1990; 170: 56-60.

Kominato Y, Hata Y, Takizawa H, et al. Expression of human histo-blood group ABO genes is dependent upon DNA methylation of the promoter region. *J Biol Chem* 1999; 274: 37240-50

Landsteiner K., 1931 Individual differences in human blood. *Science* 73: 403–409 [his Nobel Lecture, read in German at Stockholm, December 11, 1930].

Legler TJ, Maas JH, Kohler M, Wagner T, Daniels GL, Perco P, Panzer S. RHD sequencing: a new tool for decision making on transfusion therapy and provision of Rh prophylaxis. *Transfus.Med* 2001 Oct;11(5):383–388.

Lomas C, Tippett P, Thompson KM, Melamed MD, Hughes-Jones NC. Demonstration of seven epitopes on the Rh antigen D using human monoclonal anti-D antibodies and red cells from D categories. *Vox Sang* 1989;57(4):261–264.

Lucarelli E, Beccheroni A, Donati D, et al. Platelet-derived growth factors enhance proliferation of human stromal stem cells. *Biomaterials* 2003; 24:3095-100

Lucarelli E, Beccheroni A, Donati D, Sangiorgi L, Cenacchi A, Del Vento AM, Meotti C, Bertoja AZ, Giardino R, Fornasari PM, Mercuri M, Picci P: Platelet-derived growth factors enhance proliferation of human stromal stem cells. *Biomaterials* 2003, 24:3095–3100.

Mann KG, Whelihan MF, Butenas S, Orfeo T. Citrate anticoagulation and the dynamics of thrombin generation. *J Thromb Haemost* 2007; 5: 2055–61.

Marini AM, Matassi G, Raynal V, Andre B, Cartron JP, Cherif-Zahar B. The human Rhesus-associated RhAG protein and a kidney homologue promote ammonium transport in yeast. *Nat. Genet* 2000 Nov;26(3):341–344.

Marx RE, Carlson ER, Eichstaedt RM, et al. Growth factor enhancement for bone grafts. *Oral Surg Oral Med Oral Pathol Oral Radiol Endod* 1998;85(6): 638-46

McCullough J . Pathogen inactivation: a new paradigm for preventing transfusion-transmitted infections. *Am J Clin Pathol*. 2007 Dec;128(6):945-55.

McCullough J. Innovation in transfusion medicine and blood banking: documenting the record in 50 years of TRANSFUSION. *Transfusion*. 2010 Dec;50(12):2542-6.

Misso S, D'Onofrio M, Paesano L et al. Our experience in the treatment of refractory ulcers with platelet gel. *Blood Transfus* 2006; 4: 196-205

Mollison P.L. The introduction of citrate as an anticoagulant for transfusion and of glucose as a red cell preservative *British Journal of Haematology* 2000; 108: 13-18

Moon, Tara, "An Examination of the Relationship of ABO Blood Group and Lifespan in a Hospitalized Population in the Southeastern United States" (2014). VCU Theses and Dissertations. Paper 3348.

Murray S (1961) ABO groups and Rh genotypes in the elderly. *Br Med J* 2:1472–1474  
Nurden AT, Nurden P, Sanchez M, Andia I, Anitua E. Platelets and wound healing. *Front Biosci*. 2008 1;13:3532-48.

Owen R. Karl Lendsteiner and the First Human Marker Locus. *Genetics*. 2000 Jul;155(3):995-8.

Reed W, Noga SJ, Gee AP, Rooney CM, Wagner JE, McCullough J, McKenna DH, Whiteside TL, Donnenberg AD, Baker AK, Lindblad RW, Wagner EL, Mondoro TH. Production Assistance for Cellular Therapies (PACT): four-year experience from the United States National Heart, Lung, and Blood Institute (NHLBI) contract research program in cell and tissue therapies. *Transfusion*. 2009 Apr;49(4):786-96

Reid, ME.; Lomas-Francis, C. *The Blood Group Antigen Facts Book*. 2 ed.. San Diego: Academic Press; 2003

Reynolds WA. Late report of the first case of plasmapheresis for Waldenström's Macroglobulinemia. *AMA*. 1981 Feb 13;245(6):606-7

Rieger M, Mannuce P, Kremer Hovinga JA, et al. ADAMTS13 autoantibodies in patients with thrombotic microangiopathies and other immunomediated diseases. *Blood* 2005;106:1262–1267

Robertson, L.B. (1918) A contribution to blood transfusion in war surgery. *Lancet*, i, 759±762.

Robertson, O.H. (1918a) Transfusion with preserved red blood cells. *British Medical Journal*, i, 691±695.

Rouillac C, Colin Y, Hughes-Jones NC, Beolet M, D'Ambrosio AM, Cartron JP, Le Van KC. Transcript analysis of D category phenotypes predicts hybrid Rh D-CE-D proteins associated with alteration of D epitopes. *Blood* 1995 May 15;85(10):2937–2944

Rughetti A, Gallo R, Caloprisco G, Borean A, Necozone S et al. Platelet gel: assays of three growth factors. *Blood Transfus* 2006; 4: 92-101

Russi G. P. Romano, N, Lasagni D., Canovi L., Rivasi P. Therapeutic cytopheresis: rational and indication. *Lo spallanzani* (2008) 22: 35-42

Sano R, Nakajima T, Takahashi K, et al. Expression of ABO blood-group genes is dependent upon an erythroid cell-specific regulatory element that is deleted in persons with the B(m) phenotype. *Blood* 2012; 119:5301-10.

Schilling MA. Strategic management of technological innovation 4th ed. New York: McGraw Hill Irwin; 2012

Schlenke P. Pathogen inactivation technologies for cellular blood components: an update. *Transfus Med Hemother*. 2014 Jul;41(4):309-25.(1).

Scott M. Rh serology--coordinator's report. *Transfus.Clin.Biol* 1996;3(6):333–337.

Shelat SG(1), Ai J, Zheng XL. Molecular biology of ADAMTS13 and diagnostic utility of ADAMTS13 proteolytic activity and inhibitor assays. *Semin Thromb Hemost*. 2005 Dec;31(6):659-72

Shizuru J.A., Negrin R.S., Weissman Il., Hematopoietic stem and progenitor cells: clinical and preclinical regeneration of the hematolymphoid system. *Annu. Rev.Med*. 2005; 56:509-538.



Singleton BK, Green CA, Avent ND, Martin PG, Smart E, Daka A, Narter-Olaga EG, Hawthorne LM, Daniels G. The presence of an RHD pseudogene containing a 37 base pair duplication and a nonsense mutation in Africans with the Rh D- negative blood group phenotype. *Blood* 2000;95(1)

Snyder EL, Elfath MD, Taylor H, Rugg N, Greenwalt TJ, Baril L, Whitley P, Brantigan B, Story K Collection of two units of leukoreduced RBCs from a single donation with a portable multiple-component collection system. *Transfusion*. 2003 Dec;43(12):1695-705

Solomon A, Fahey JI. Plasmapheresis Therapy in Macroglobulinemia. *Ann Intern Med*. 1962;56(4):690-691

Tang YQ, Yeaman MR, Selsted ME. Antimicrobial peptides from human platelets. *Infect Immun*. 2002; 70(12):6524-33.

Taylor DW, Petrera M, Hendry M., Theodoropoulos JS. A Systematic Review of the Use of Platelet-Rich Plasma in Sports Medicine as a New Treatment for Tendon and Ligament Injuries. *Clin J Sport Med* 2011;21:344–352

Tokiko Nagamura-Inoue and Haiping He. Umbilical cord-derived mesenchymal stem cells: Their advantages and potential clinical utility *World J Stem Cells*. Apr 26, 2014; 6(2): 195–202.1.2.4

Tsai HM, Lian EC. Antibodies to von Willebrand factor-cleaving protease in acute thrombotic thrombocytopenic purpura. *N Engl J Med* 1998;339:1585–1594

Vaglio S Blood: the last 20 years of discovery. *Med Secoli*. 2005;17(3):803-9.

Wagner FF, Gassner C, Muller TH, Schonitzer D, Schunter F, Flegel WA. Molecular basis of weak D phenotypes. *Blood* 1999 Jan 1;93(1):385–393

Westhoff CM. The potential of blood group genotyping for transfusion medicine practice. *Immunohematology* 2008;24(4):190–195.

Yamamoto F, Cid E, Yamamoto M, Blancher A. ABO research in the modern era of genomics. *Transfus Med Rev* 2012; 26: 103-18

Yamamoto F-I, Clausen H, White T, et al. Molecular genetic basis of the histo-blood group ABO system. *Nature* 1990; 345: 229-33.

Zheng XL. Structure–function and regulation of ADAMTS-13 protease. *J Thromb Haemost* 2013; 11 (Suppl. 1): 11–23.

*Un sentito ringraziamento a tutti coloro che hanno accompagnato e guidato, dalla laurea ad oggi, la mia passione per la Medicina Trasfusionale.*

*Al prof. Caruso, che ha fortemente voluto la mia presenza in questo ambito, va il mio più sincero e riconoscente “grazie”.*

*Grazie alla mia famiglia, passata e presente, che ogni giorno, supporta e “sopporta” le mie scelte.*