



A DECISION SUPPORT SYSTEM FOR SUSTAINABLE OPERATIONS MANAGEMENT IN SMALL POWER PLANTS

G. Aiello^{1*}, M. Enea, G. La Scalia and F. Longo²

¹Dipartimento di Ingegneria Chimica Gestionale Informatica, Meccanica

Università di Palermo, Italy

giuseppe.aiello03@unipa.it

mario.enea@unipa.it

giada.lascalìa@unipa.it

²SEA-Società Elettrica di Favignana

fabrizio.longo@seafavignana.com

ABSTRACT

The importance of environmentally-friendly electricity production is recognized as one of the most important challenges of our future, covering a broad context of research topics and promoting future scenarios based on renewable energies and new technologies. In the short term, however, energy generation will still be largely relying on power plants fired with fossil fuels whose emissions of pollutants are regulated by the industrial emissions directive in the EU legislation. Such directive does not apply to small and medium combustion plants, which until now, have only been subject to national regulations. As part of its air quality package from December 2013, the EU Commission has proposed a new directive which forces such plants to provide periodic measurements of pollutants, keep records of their environmental impact and provide information to the competent authorities. This situation has renewed the attention towards the systems for continuous emission monitoring in SMC. Such systems are in fact very expensive, therefore they require an optimized design in order to be affordable for a SMC. This research, in particular, refers to the context of micro-grids and isolated power generation plants based on a set of diesel engine generators (GenSet) and addresses the topic of the development decision support systems (DSS) for environmentally-friendly power genset management. The system is based on a Selective Catalytic Reduction (SCR) reactor coupled with continuous emission monitoring system (CEMS) to reduce the environmental impact and generate information to support the management processes. The paper also reports the preliminary experimental results obtained in the power plant located in the small island of Favignana in the Mediterranean sea. These results demonstrate how the system developed and the approach proposed reduces the emission of pollutants with a substantial benefit for the local community, in a context where more environmentally efficient production technologies can hardly be employed.

Keywords: Decision Support Systems, Environmental efficiency, power generation, Continuous Emission Monitoring System.

1 INTRODUCTION

* Corresponding Author

Hazardous chemicals released in the atmosphere by anthropogenic activities are the major cause of environmental air pollution. In particular, the combustion of fossil fuels, used for the generation of energy and transportation are responsible of the most significant changes in the atmospheric composition. Power plants that are fired with fossil fuels are in fact big emitters of air pollutants, including sulphur dioxide, nitrogen oxides, fine particles, and greenhouse gases such as carbon dioxide. Considering that fossil fuels are the most employed energy sources, and that global consumption of commercial forms of energy has increased steadily over the last four decades at an average annual rate of 3.2% in the countries with emerging economies and 1.1% for developed countries (IEA, International Energy Agency), the enforcement of proper countermeasures has become a global emergency. Additionally, environmental consciousness has also been increasing in the last few decades, and people are now aware of the world's environmental problems such as global warming, toxic substance usage, and decreasing in non-replenish resources [1]. For such reasons, environmentally-friendly electricity production is nowadays recognized as one of the most important challenges of our future, covering a broad context of research topics and promoting future scenarios based on renewable energies and new technologies.

In the short term the fossil fuel industry, which has perhaps come under the harshest criticism from environmental groups and environmentally conscious consumers, still remains the most common fuel source for power generation even in fragile ecosystems. It is well known that a great part of the emissions comes from a relatively small number of large combustion plants (LCP), whose emissions are covered by the industrial emissions directive (IED) in the EU legislation. Medium Combustion Plants (MCP) with a thermal input between 1 and 50 megawatts are also employed for a wide variety of applications (electricity generation, domestic/residential heating and cooling and providing heat/steam for industrial processes, etc.) and their pollutant emissions, until now have only been subject to national regulations. As part of its air quality package from December 2013, the EU Commission has proposed a new directive which should cover nearly 143,000 medium-sized combustion plants (MCPs) now in operation in the EU. According to such proposal, MCPs should provide periodic measurements of pollutants, keep records of their environmental impact and provide information to the competent authority upon request.

As a consequence of increasingly tight environmental regulation in western countries and of the spread of environmental consciousness, industrial companies are recognizing the need for shifting to more environmentally conscious practices by modifying their existing processes and implementing new technologies to minimize environmental impact and pollution. In the early 21st century, the corporate social responsibility (CSR) concept seems to have great potential for innovating business practices with a positive impact on people, planet and profit [2]. The move up the ladder of a company's commitment to sustainable development can go through phases of gradual improvements of environmental and social performance. The awareness of current and potential conflict of interest between economic growth and environmental preservation has resulted in the concept of sustainable development referred to the ideal situation where principles of sustainable development are an integrated part of a company's business strategy and long term planning, thus encompassing economic, social, ecological, technological and ethical perspective in a multidimensional concept. In the recent years, environmentally conscious management has emerged as an important aspect of CSR, referred to the control exerted over all immediate and eventual environmental effects of production processes. To improve the control of their environmental performance, organizations can develop environmental strategies varying from opportunistic compliance to voluntariness [3]. Understanding what really motivates corporate environmentalism is necessary for planning organizations' actions.

In particular, the case here considered focuses on including environmental and social issues in the management decisions of a small power generation company devoted to eco-efficiency, and on the proactive development and implementation of effective tools to support its decision processes. A viable roadmap towards such objective is the

implementation of an advanced environmental management system (EMS), which provides a structured framework for managing an organization's environmental performance. International EMS standards have been developed for voluntary use by different types of organizations in recent years, one such set of standards is the ISO 14000 which aims at the establishment environmental performance goals, and the consequent measurement of the overall environmental performance of the organization. The relevance of such topic in a modern approach to plant management is confirmed by the tools and metrics that have been developed to measure the environmental impact of a products and organizations. A metric that has gained prominence in recent times is the carbon footprint (CFP), which quantifies the climate change impact of greenhouse gas (GHG) emissions and is thus often used as an environmental performance indicator for products and production activities. Carbon footprints measure the sustainability and environmental impact of anthropic activities on climate change in order to manage resources throughout the global economy [4].

As a result, to comply with the forthcoming regulations, and to be proactive in their social responsible practices, SMC must implement efficient pollution abatement and monitoring systems. In such context the pollution from fossil fuel combustion for energy production may be reduced through a number of measures:

1. switching to fuels with low emission potential,
2. installing post-combustion cleaning system, and
3. dispatching of generation to each generator unit with the objective of minimum emission dispatch.

Since the first option is limited to the commercially available fuel alternatives, this study will focus on the last two opportunities: in particular, the study assesses the scope for reducing pollutant emissions by applying Emission Control Technologies (ECT) for MCPs and of monitoring their environmental performance. According to operational decisions, such as those related to proper load dispatch or unit commitment, the company needs to have a complete visibility of its pollutant emissions based on operational data. The design and deployment of a novel Multi Point Continuous Emission Monitoring System (CEMS) as a technological infrastructure to support the EMS is therefore discussed. The preliminary results obtained, finally, demonstrate the improvement in the environmental performance of the organization and promote the development of proper Decision Support Systems for environmentally conscious management.

2 ISOLATED POWER GENERATION SYSTEMS

In isolated communities with low population densities, supplying electricity by extending the transmission line from national power grid is costly or even impossible because of geographical constraints. Therefore, such communities utilize their own generation and distribution system to supply electricity, according to the so called "mini-grid" scheme. In such situation, where isolated power generation systems have to meet the power demand of a location coping with techno-economic constraints, power generation is generally based on diesel generator (DG) sets. A diesel engine/generator set, commonly referred to as genset, consists of two main parts: a four strokes Internal Combustion Engine (ICE) and an alternator which is usually a synchronous generator. Those two parts are coupled on the same shaft to work as a unit to convert the chemical energy in the fuel to electrical energy. Load curves in isolated locations may exhibit a varying load profile, as it is particularly evident (see figure 1) in the island considered, because of the strong seasonality during summer due to the touristic presences. In such situations, DG systems sized on the basis of expected peak demand would result in generator operation at part-load conditions for large durations of time. For such reason, and to avoid the genset to work at light load, multi genset systems with different generators size connected in parallel are generally used. Therefore, the widespread use of gensets in such contexts is mainly due to their wide modularity, high power-to weight ratio, affordable pricing, quick start-up and shutdown, and small space

requirements. Additionally the high variability of demand, poses some difficulties in the regulation of pollution abatement systems, which in turn must be able to adapt to different conditions, as it will be discussed below.

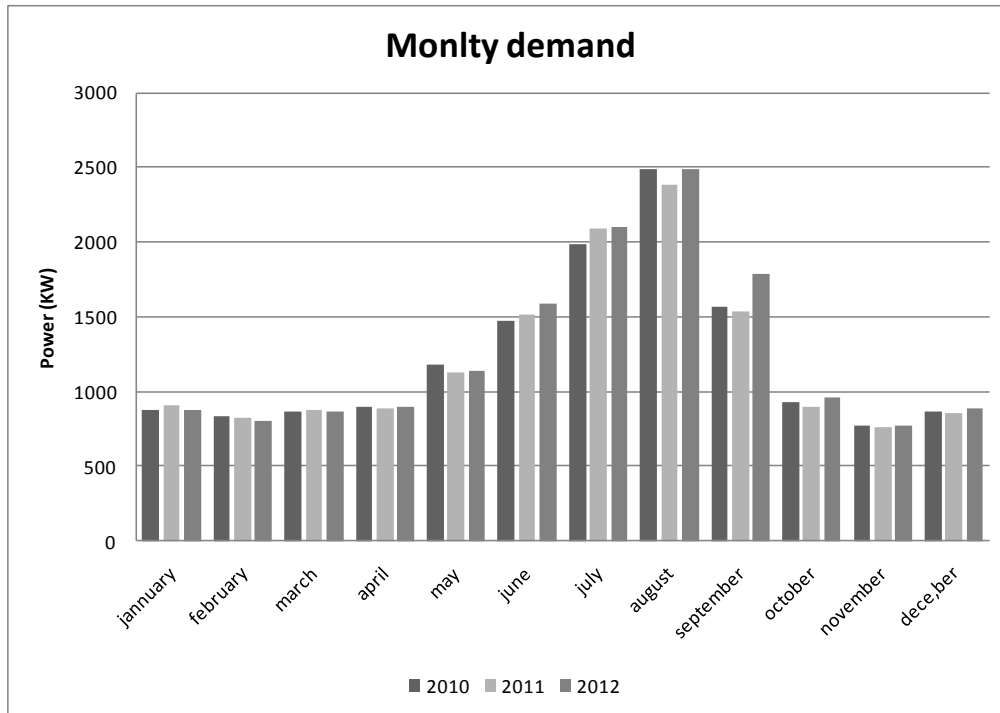

Figure 1: Electricity demand curve in the island of Favignana in the last years.

In particular, the context we are referring to is the island of Favignana in the Mediterranean sea, where electricity is provided by a MCP operated by SEA Società Elettrica di Favignana s.p.a. The plant involves a modular genset constituted by 5 different generators arranged in two platforms, as given in the following table 1

<i>Location</i>	<i>Name</i>	<i>model</i>	<i>Power (kW)</i>
Platform 1	Generator 1	DEUTZ BV9M628	2025
	Generator 2	DEUTZ TBD620V16	1760
	Generator 3	DEUTZ TBD620V16	1760
Platform 2	Generator 4	DEUTZ BV8M628	1800
	Generator 5	DEUTZ BV6M628	1350

Table 2: Genset configuration in the Power Plant

3 ENVIRONMENTAL MANAGEMENT AND DECISION MAKING.

In this section the issues related to the environmental performance of the production system are discussed referring to their implications in operation and management processes of medium power plants. As stated before, plant managers and decision makers are facing increased pressure to deal with production planning problems, considering both economic

and environmental objectives. Such issue is nowadays becoming a priority for plant managers as well as for regulatory agencies, and classical approaches to the optimization of production processes based on economic objectives only are inadequate. Therefore, a new research area focused on the development of optimization models considering both economic and environmental objectives is now being investigated.

Concerning the management of gensets, generator units have traditionally been dispatched following minimum fuel cost criterion, according to the traditional formulation of the Economic Load Dispatch (ELD) problem. ELD determines the optimal distribution of system load to the generators in order to have minimum generation cost while meeting the load demand. The mathematical formulations of this problem mainly belong to the class of linear programming, goal programming, neural networks and evolutionary algorithms. A survey on the literature of the economic dispatch problem can be found in [5]. Recently, due to the issues above discussed, new formulations have been proposed with the aim of minimizing the environmental impact related to air pollution. The introduction of environmental objectives in the economic optimization model is performed in much the same way as the economic power dispatch with the additional goal to reduce pollutants emissions. The main idea in the new dispatch techniques is based on employing more generation units that give less emission in order to reduce the amount of total emission. This new approach to power generation has led to the Economic/Environmental unit Dispatch problem (EED), which concerns electricity production at the cheapest possible cost with minimum levels of pollution. Since the cost and the pollution objectives are conflicting in nature, (EED) is a multiobjective optimization problem (MOP) with noncommensurable and contradictory objectives. The first approaches to the solution of such problem reduced the MOP to a single objective problem by treating the emissions as a constraint with a permissible limit or by employing a weighted sum approach. Recent researches handle both objectives simultaneously thus maintaining the original multi objective nature of the problem, in what is more properly defined Combined Economic and Emission Dispatch (CEED) problem. In the literature, a multi-objective economic dispatch problem was solved by using various solution methods like linear programming [6], Newton-Raphson algorithm [7], fuzzy linear programming [8]. More recent approaches use multi-objective genetic (or modified genetic) algorithm [9,10,11], fuzzified multi-objective particle swarm optimization algorithm [12].

In order to solve the problem in a multi-objective approach, however, proper objective functions must be established for each objective: the organization must hence be able to calculate and measure its economic and environmental performance. The cost function of the economic dispatch problem can be formulated by using quadratic or cubic functions of generated power. In the Literature, most of the papers consider only second order polynomial function for economic dispatch problem formulation [13]. Similarly, sulphur oxides, carbon oxides, and nitrogen oxides caused by fossil fueled thermal units can be modeled separately as individual mathematical relationships between operational parameters (e.g. fuel flow, load, and ambient air temperature) and emission rates. This approach is generally referred to as Predictive Emission Monitoring System (PEMS). PEMS is a model based environmental performance evaluation, which is considered an alternative to the direct measurement of the pollutant concentrations in exhaust gases, typically performed by a Continuous Emission Monitoring System (CEMS). Both PEMS and CEMS systems are approved for verifying emission compliance by many environmental authorities, however mathematical models are parametric and must be accurately calibrated to the specific diesel generators in order to provide reliable data. For such reason PEMS data are generally fairly approximated, while CEMS is capable of measuring stack gases with higher accuracy and reliability. In general, PEMS have proven to be particularly successful for uniformly operated units, such as gas turbines, and they are a simple and cost-effective option for emission measurement as far as reporting to the supervising authorities is the purpose. In the case here considered, the issue of pollution abatement and control is approached in the broader framework of environmental conscious plant management referring to the

implementation of an EMS able to provide reliable monitoring and reporting functions to the plant management. In such situation, a reliable data monitoring system is required for improved decision-making in operational and strategic management, thus being a part of a broader Decision Support System (DSS) aimed at fulfilling the following objectives:

1. Production related objectives:
 - a. Optimized Unit Commitment considering economic and environmental objectives;
 - b. Optimized Urea injection for maximizing the abatement rate of SCR reactors;
 - c. Early detection of system malfunctioning to avoid increased atmospheric pollution and/or catastrophic failures;
 - d. Generate financial savings through well-managed use of resources and efficient practices;
2. Environmental related objectives:
 - a. Emission Calculation & Reporting;
 - b. Evaluate key environmental performance indicators (EFP, etc..);
 - c. keep for emissions inventories;
 - d. assessing environmental impacts;
 - e. retrieve data for emissions trading programs;
 - f. comply with environmental laws and regulations;
 - g. share data among the stakeholders.

4 POLLUTANT ABATMENT SYSTEM

As stated before, the principal air pollutants resulting from fossil fuel combustion are carbon monoxide, oxides of sulfur (SO_x) oxides of nitrogen, (NO_x) and 'particulates' consisting primarily of very fine soot and ash particles. Air pollution may result also from unburned hydrocarbons which either pass through energy conversion devices without burning or escape into the air by evaporation before they can be burnt. These pollutants can further interact with the environment to generate additional deleterious effects. SO₂ for example has been a cause of acid precipitation, commonly known as "acid rain. Additionally fossil fuel combustion is also responsible of the concentrations of "greenhouse gases" (GHGs) that are in the atmosphere. GHGs influence the planet's ability to retain solar heat, thus being responsible for the Global Warming effect. Power plants fueled by fossil fuels produce large amounts of CO₂ which, at this time, are unregulated in the legislation on air emission, but they generate a cost according to the European Union's Emissions Trading System (ETS).

Due to their emissions of pollutants, operating power plants that burn coal, oil, or natural gas, requires the plant to be fitted with suitable pollution control equipments. This issue is regulated within the European Union under the Integrated Pollution Prevention and Control (IPPC) regulations which provides a detailed guidance on application of Best Available Techniques (BAT). This guidance applies to electricity generating LCPs using conventional fuels. Smaller combustion plants face many of the same environmental issues, although they are subject to less rigorous regulatory attention. However, since national and European regulations are expected to tighten in the immediate future, the issue of reducing pollutant and GHG gas emissions is now gaining consideration in companies running MCPs. Current practices to reduce NO_x emissions in stationary combustion plants make use of two approaches:

1. The control of pollutants formation through combustion modifications, namely "Primary measures";
2. The downstream removal pollutants from flue gas by means of specific treatment technologies namely "Secondary measures";

Primary measures require a high liquid fuel quality, which may not be commercially available, while secondary abatement techniques are more commonly employed since they can be retrofitted into existing plants. In particular we are focusing on the downstream

removal of NO_x, where “post combustion” technologies like Selective Catalytic Reduction (SCR) and Selective Non Catalytic Reduction (SNCR) are identified as the most effective. SCR occurs at temperatures of 300-400°C and it is theoretically capable of a reduction rate of nitrogen oxides of 80-95%. SNCR occurs at temperatures of 900-1000°C in the absence of catalysts, and the rate of reduction of nitrogen oxides is 30-50%. In the MCP plant considered, due to the specific features of the production process based on multiple gensets, the SCR abatement system has been selected as the most appropriate technique. SCR reactors in fact can easily be retrofitted on 4-stroke diesel engines because there is a sufficiently high exhaust temperature to allow efficient catalyst operation after the turbocharger (see fig. 2). The SCR system converts nitrogen oxides into nitrogen and water, by means of a reducing agent (typically Urea) injected into the engine exhaust stream. A proper dosage of the reducing agent allows the reactor to operate efficiently in different load conditions. An SCR system comprises the following main components:

- a pumping unit for transfer of urea solution from storage;
- a urea dosing unit;
- a mixing duct with urea injection point;
- a reactor housing containing replaceable catalyst blocks;
- a control system;
- a soot/ash cleaning system.

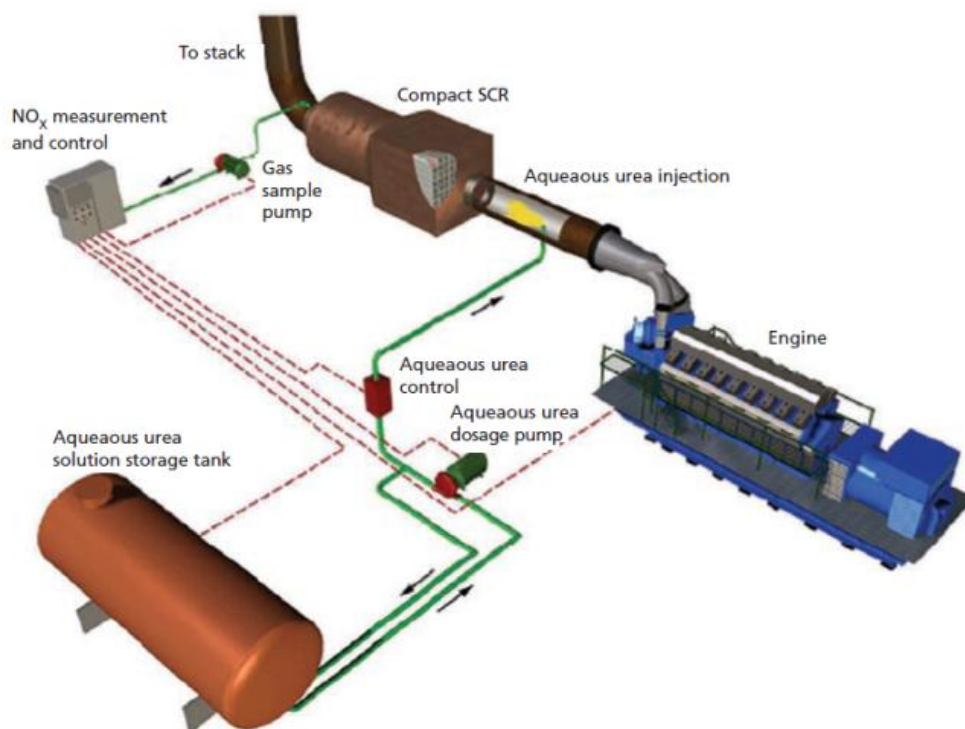

Figure 2 - SCR retrofitting scheme

SCRs are capable of converting a very high percentage of NO_x in steady state, however, transient engine operation creates difficulties in controlling the quantity of urea injected. This issue is particularly significant in the context considered, due to the above mentioned high seasonal variability of the demand, and it dictates the need for a urea dosage controller to maximize NO_x reduction. Insufficient injection rate in fact results in low conversion of NO_x while a too high injection rate results in an undesirable release of unconverted ammonia to the atmosphere (“ammonia slip”). For such reason an NO_x probe is frequently installed after the SCR reactor in order to optimize the urea injection rate for maximum reactor efficiency.

Retrofitting the SCR reactors in the power plant in Favignana required a complete re-design of the exhaust pipes and support structures (see fig 3). The new piping layout involves the exhaust gases coming from the 5 generators to be conveyed to two different emission points. Each generator has its own silencer, diesel particulate filter (DPF), diesel oxidation catalyst (DOC), as well as its SCR unit and urea dosage control unit.

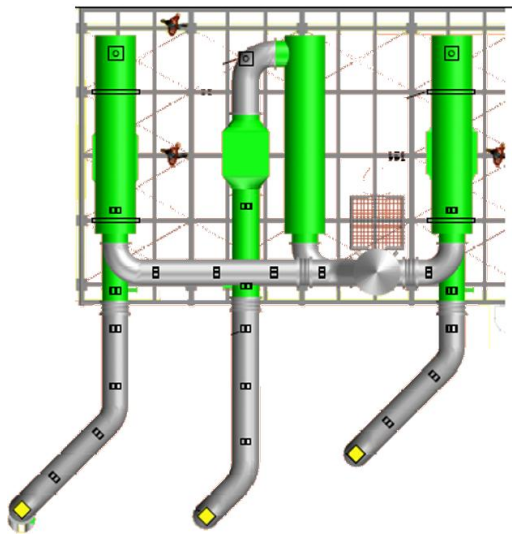

Fig. 3 (a) Exhaust Piping Layout - Platform 1

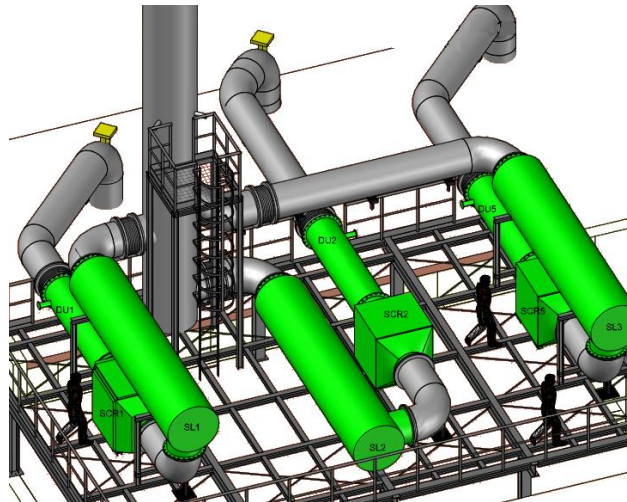

Fig. 3 (b) Perspective view- Platform 1

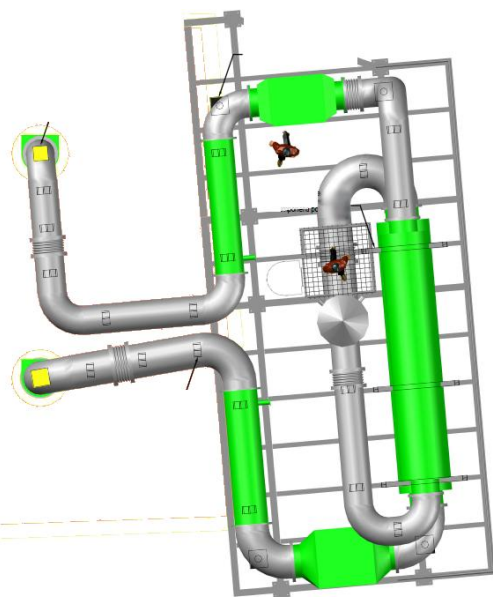

Fig. 3 (c) Exhaust Piping Layout - Platform 2

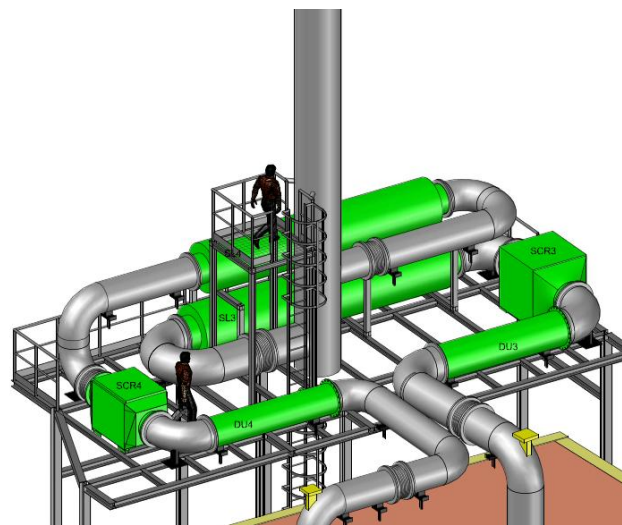

Fig. 3 (d) Perspective view- Platform 2

Figure 3 - Exhaust Piping

5 CONTINUOUS EMISSION MONITORING SYSTEM

As stated before, the implementation of an advanced environmental management system involves the organization to have a clear visibility of its environmental performance. For a MCP the environmental performance is mainly linked to the amount of pollutants released in

the atmosphere. In order to measure the environmental performance of the power plant considered in this study, hence, a CEMS has been installed, capable of sampling the exhaust gases from the generators and measuring the concentration of pollutants. Additionally, the CEMS will allow the organization to continuously acquire measurements of pollutants, keep records of environmental impacts and provide information to the competent authority upon request as required by the forthcoming EU directive for MCPs. The continuous emission monitoring system (CEMS) installed in the power plant belongs to the category of extractive-direct systems where the sample is taken from the stack with a probe and is transported to the analyzer housing. The sample passes through a heated transfer line in order to prevent the moisture from condensing, then it is conditioned, before entering into the analyzer. The sample conditioning phase also removes the moisture, so that the measurement is made on dry basis thus not being affected by changes in the flue gas temperature, pressure or particles. The main features and components of the extractive CEMS installed in the Power Plant of Favignana are depicted in the scheme given in figure 4, and described below.

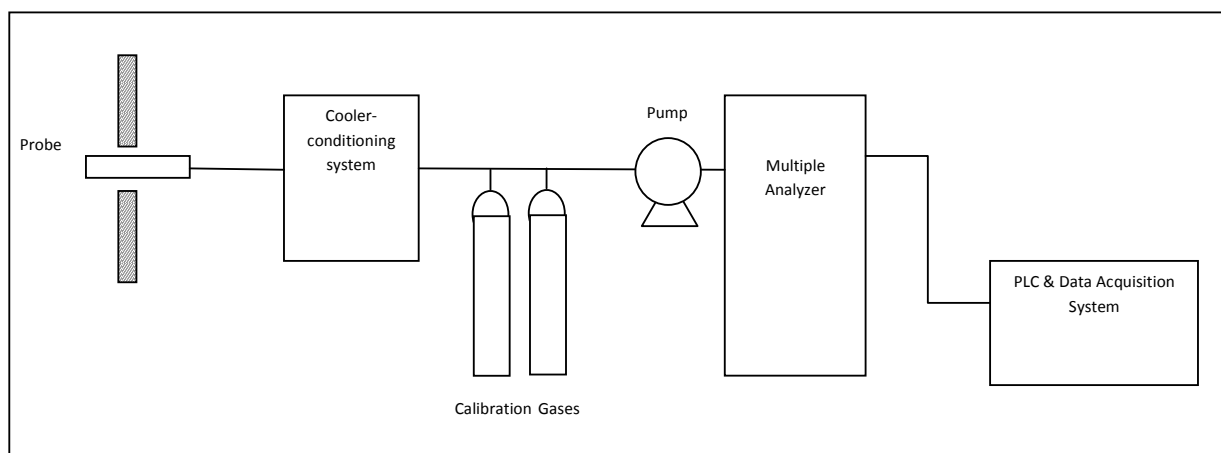

Figure 4 - Extractive CEMS schematic

Effluent/CEM system interface. The effluent/CEM system interface consists of a rigid probe, positioned at a representative location in the effluent. A variety of coarse filtration media, usually located at the probe inlet, is used to remove particulate matter from the gas sample.

Sample transport system. The sample transport system begins at the junction between the probe and the sample transport line, positioned just outside the duct. The sample transport systems consist of sample heated transport line and a pump to move the gas sample from the probe, through the heated line, to the analyzer.

Sample conditioning system. Gas samples generally require some form of conditioning before they are suitable for gas analysis. The sample conditioning system, hence, involves pressure regulators, coolers or heaters, and filters in order to provide a clean, dry, interference-free sample to the analyzers.

Calibration System. The calibration system is constituted by a set test gas cylinders to be fed into the gas analyzer each time a calibration is performed. Periodic calibration is necessary for efficient CEMS operation, in order to ensure reliable measurements.

Pollutant analyzer. The analyzers employed is a manufactured by SICK and is based on Non-Dispersive Infrared (NDIR) technology which and is able to analyze SO_2 , NO_x , CO_2 , CO , and other gases simultaneously. Non-dispersive infrared (NDIR) technology employs a dual-beam (reference and sample) optical system where an Infrared radiation of equal intensity is passed through both the sample and reference cells. The reference cell is filled with a dry gas that does not absorb the infrared radiation while the sample gas flows continuously



through the sample cell thus absorbing part of the light passing through the sample. After the light has passed through the reference and sample cells, it enters the detector section of the analyzer where the difference in intensity of the light is measured. Due to the absorption of infrared energy in the sample cell, the intensity of the two light beams differs. The greater the difference, the greater the amount of target gas in the sample. The analyzer can also distinguish between different gas species, because only infrared radiation in a specific band is absorbed by the detector.

Computerized multi point emission sampling system. The most significant part of the system is constituted by the computerized multi point emission sampling system which has been designed and realized with the aim of measuring with the same analyzer the concentration of pollutants coming from different emission points. The power plant considered, in fact, involves two different emission points where the exhaust gases from different generating units are conveyed to. The computerized multi point emission sampling system is based on a Programmable Logic Controllers (PLC) which executes a sampling loop sequentially on each stream originating from the different measurement points. During the sampling loop the PLC initially switches the position of an electro-valve to the stream to be analyzed, then delays the pollutants analysis until the sample transport line is filled with the new stream, subsequently the analyzer is activated for the measurement phase. After a pre-established measurement period, the analyzer is de-activated and the loop restarts. Finally, a Data Acquisition System (DAS) connected to the analyzer, gathers the data and attributes them to the related emission point. The computerized multi point emission sampling system, hence, allows the employment of a single analyzer for measuring the emission of multiple sources, thus significantly reducing the instrumentation cost as well as the operation cost related to the analyzer's maintenance and calibration. The drawback is represented by the higher cost of the heated sample transport lines.

The final piping and Instrumentation (P&I) diagram of the system is given in figure 5. Note that an additional emission point is considered in the system for possible upgrade of the plant's production capacity.

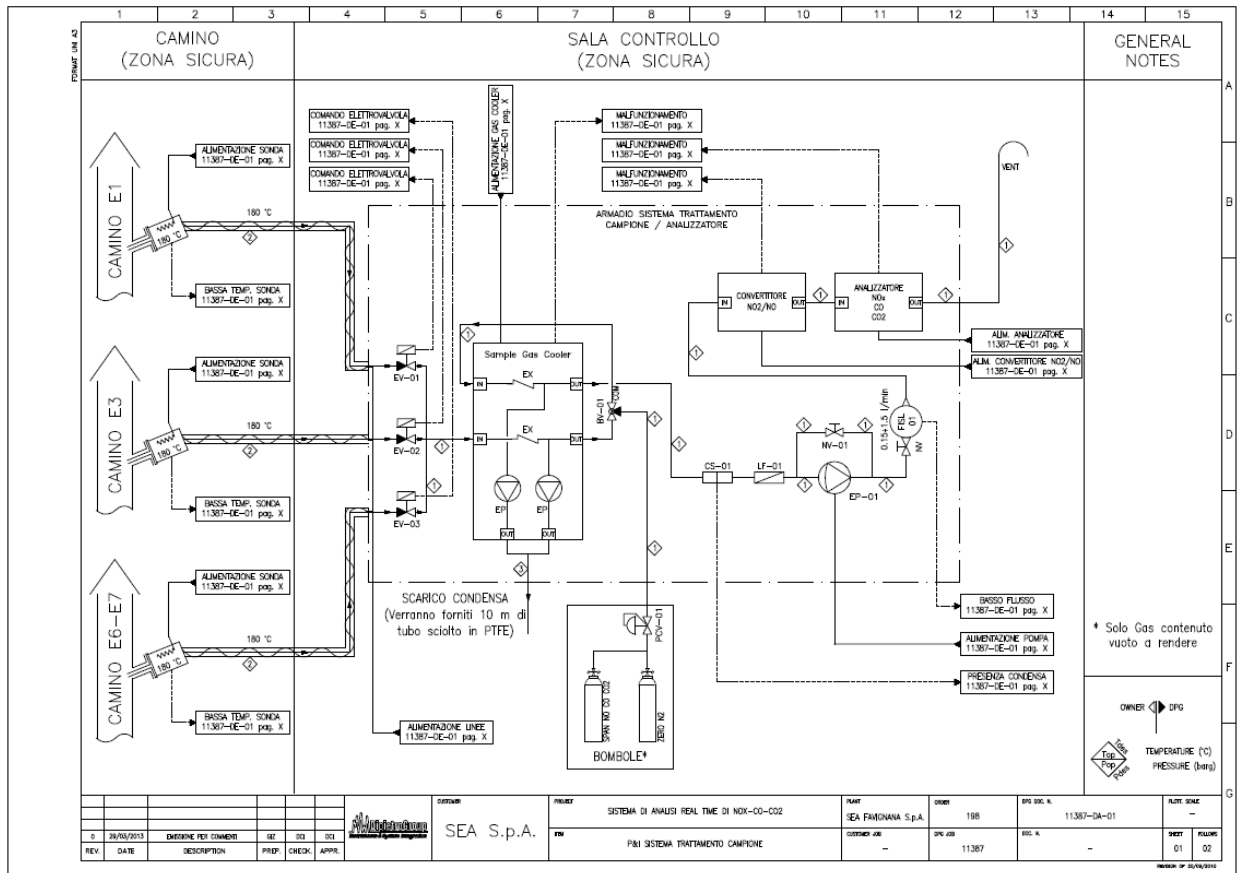

Figure 5: Schematic of the Emission monitoring System (courtesy of Dipietro Group s.r.l.)

6 RESULTS

Computed results for the specified system are presented in figure 6 where the values of the system load and the hourly emissions of NO_x and CO are reported, measured during 6 hours of activity at a similar operating condition (constant power load, aprox. 1100 kW) for the same generator (generator 1). The results show reduction in the NO_x emissions of approx. 50%, as the SCR system is activated, which is far from the expected 80-90% but this is probably due to the non-optimal Urea injection control. On the contrary the CO emission level is similar in the two cases, as it is not affected by the SCR system. The comparison between these two cases in terms of minimum, average and maximum NO_x emissions is given in table 2. The results here presented are preliminary, and detailed statistical data analysis in different loading conditions is currently being performed and mathematical emission models are being developed.

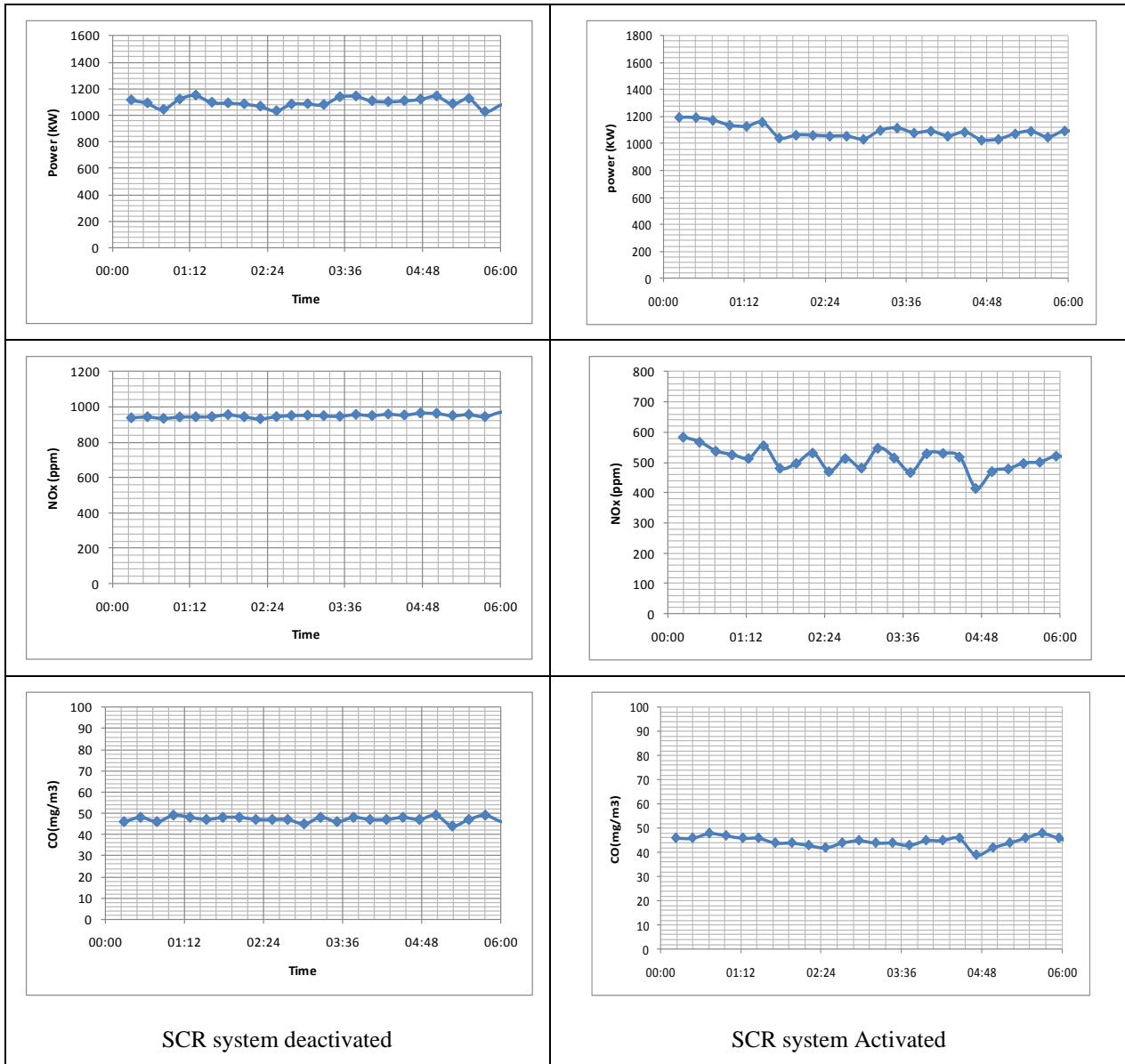

Figure 6: Measured Pollution

	SCR	NO SCR
max	583	1002
avg	510,125	951,2917
min	415	933

Table 2 Measured NOx Concentration (ppm) with and without the SCR system

7 CONCLUSIONS

The research presented focuses on the problem of introducing environmentally conscious practices in the management processes of a small power combustion plant. As stated before, the tightening of environmental regulations and the increased environmental awareness require a revised approach towards the optimization of production processes, which now has to take into account not only economic but also environmental objectives. According to such issues, new organizations must develop new operational and strategic decision making processes, which must be adequately supported by proper information. In this paper such issues are discussed referring to the particular case of a medium combustion plant for power generation located in an isolated grid, where a pollution control and abatement system has been developed and installed to improve and evaluate the environmental performance of the organization. The system developed is based on a SCR reactor for NO_x reduction and a multiple analyzer able to measure the concentration of some pollutants and GHG gases by means of NDIR technology. The emission monitoring system and involves a novel computerized multi point emission sampling system to measure the stream coming from multiple emission points by means of a single analyzer. Such solution allows to significantly reduce the investment cost, which otherwise would be prohibitive for a small company. The results show the comparison between the emission levels before and after the installation of the SCR pollution abatement system, thus demonstrating the increased environmental performance. This preliminary result, however is just the first step towards the development of a database of the environmental performance of the facility, which can be exploited for modeling the relation between the amounts of pollutant released and the power output of the generating units. This, in particular, is a key issue for taking into account the environmental objective in tactical and strategic management decision problems, such as unit dispatch, optimum urea injection control, etc.

8 ACKNOWLEDGEMENTS

the authors are grateful to eng. Domenico Santisi, Saverio Pantaleone, Dipietro Group s.r.l. and Leonardo Engineering s.r.l. for collaborating in the design and development of the emission monitoring system, and to Hugh Engineering for providing information on the SCR pollution abatement system.

9 REFERENCES

- [1] Khiewnavawongsa, S., Schmidt, E.K., 2008. Green Power to the Supply Chain. Proceedings of the Annual Meeting of the Association of Collegiate Marketing Editors: pp.244-251.
- [2] Zwetsloot, G. I., 2003. From Management Systems to Corporate Social Responsibility. *Journal of Business Ethics*, 44: pp.201-207.
- [3] Özen, Ş. and Küskü, F., 2009 Corporate Environmental Citizenship Variation in Developing Countries: An Institutional Framework, *Journal of Business Ethics*, 89(1), pp. 297-313.
- [4] Visser, W., Matten, D., Pohl, M., Tolhurst, N., 2007 *The A to Z of Corporate Social Responsibility*, Wiley, London
- [5] B. H. Chowdhury and S. Rahman, 1990, A review of recent advances in economic dispatch, *IEEE Transactions on Power Systems*, 5 (4), pp. 1248-1259,
- [6] Farag A., Al-Baiyat S., Cheng T.C., 1995, Economic Load Dispatch Multi-objective Optimization Procedures Using Linear Programming Techniques", *IEEE Transactions on Power Systems*, 10(2), pp.731-738
- [7] Chen J.F., Chen S.D., 1997, Multiobjective Power Dispatch with line Flow Constraints Using The Fast Newton-Raphson Method, *IEEE Transactions on Energy Conversion*, Vol. 12, No.1, pp. 86-93.



- [8] Yang H.T., Huang C.M., Lee H.M., Huang C.L., 1997, Multi-objective Power Dispatch Using Fuzzy Linear Programming, *IEEE Transactions on Energy Conversion*, 12 (1) pp. 86-93.
- [9] Younes M. Benhamida F., 2011, *Genetic Algorithm-Particle Swarm Optimization for economic load dispatch* ISSN 0033-2097
- [10] Rughooputh H.C.S., Ah King R.T.F., Environmental /Economic Dispatch of thermal units using an elitist multi-objective evolutionary algorithm, *IEEE int. Conf. Tech.* pp 48-53, 2003
- [11] M.A. Abido, 2003 niched Pareto genetic algorithm for multiobjective environmental/economic dispatch, *International Journal of Electrical Power & Energy Systems* 25 (2), Pages 97-105
- [12] Niknam T., 2010 A new fuzzy adaptive hybrid particle swarm optimization algorithm for non-linear, non-smooth and non-convex economic dispatch problem, *Applied Energy Volume 87(1)*, Pages 327-339
- [13] A.J. Wood, B.F. Wollenberg, *Power Generation, Operation and Control*, 2nd ed., John Wiley & Sons, Inc., New York, NY, 1996