



University of HUDDERSFIELD

University of Huddersfield Repository

Fieldhouse, John D., Bryant, David and Talbot, Chris J.

Investigation of brake squeal and the influence of the abutment faces.

Original Citation

Fieldhouse, John D., Bryant, David and Talbot, Chris J. (2010) Investigation of brake squeal and the influence of the abutment faces. In: Proceedings of 6th European Conference on Braking, JEF 2010. European Conference on Braking . Groupement Regional Nord/Pas-de-Calais pour la Recherche dans les Transports, Universite de Lille 1, France, pp. 255-262.

This version is available at <http://eprints.hud.ac.uk/9179/>

The University Repository is a digital collection of the research output of the University, available on Open Access. Copyright and Moral Rights for the items on this site are retained by the individual author and/or other copyright owners. Users may access full items free of charge; copies of full text items generally can be reproduced, displayed or performed and given to third parties in any format or medium for personal research or study, educational or not-for-profit purposes without prior permission or charge, provided:

- The authors, title and full bibliographic details is credited in any copy;
- A hyperlink and/or URL is included for the original metadata page; and
- The content is not changed in any way.

For more information, including our policy and submission procedure, please contact the Repository Team at: E.mailbox@hud.ac.uk.

<http://eprints.hud.ac.uk/>

Investigation of brake squeal and the influence of the abutment faces

JD Fieldhouse, D Bryant, CJ Talbot.

The University of Huddersfield, UK

j.d.fieldhouse@hud.ac.uk

Abstract:

This paper demonstrates the influence of the trailing end of the piston, or inboard, pad on the propensity of a brake to generate audible squeal. The unique technique was employed to measure the dynamic centre of pressure at the pad/disc interface during a normal braking operation. This novel technique uses an embedded pressure sensitive film within the pad. The paper also presents the co-planar analysis of the pad/caliper contact regions and its influence on the position of the disk/pad “Centre of Pressure” (CoP). The analysis shows how the trailing end of the piston pad influences the position of the CoP and goes on to explain why the centre moves as the pad abutment vibrates against the abutment. The paper includes additional work with a 12 piston opposed caliper where the initial CoP may be varied both along the pad and radially. Results show a very definite movement of the centre of pressure as the brake pressure is increased.

Key words: Pad abutment, Centre of Pressure, Spragging.

1. INTRODUCTION

Over 20 years ago brake noise was described as fugitive in nature – it was unpredictable. That statement is as true today as it was then which gives some idea of our advances in understanding the problem. Noise may be “fixed” in a number of ways but the term “fix” means repair, mend or patch-up. The solution is not applicable to another system and possibly not another frequency on the same brake. The “fix” is often derived from many tried and tested “fixes” and once found the industry moves on to the next problem, not questioning why the “fix” worked.

Most brake noise researchers will have inserted a screwdriver into the brake to see if they can stop the noise – and often they can.

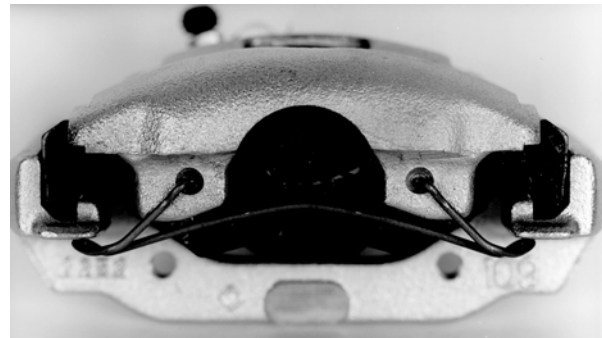

Figure 1 – Caliper with spring connecting caliper and carrier bracket.

Levering the caliper against the carrier bracket often makes a difference and springs are introduced to give the same effect. Such a spring is shown in Figure 1. Pushing the screwdriver between the pad abutments also has some effect but transposing this to a practical and economical design modification can prove difficult. Using some low friction grease at the pad abutments and the cylinder/pad interface also has some effect but may cause issues if it transfers to the braking faces. Noise fix shims also provide a solution at the high frequencies, their introduction being to damp out the system vibrations. Added mass to the pad backplates and the carrier fingers also prove useful in some cases but once introduced the modification remains as part of the design, forever. It takes a brave designer to remove a “fix”.

Other characteristics of brake noise are that it occurs at the lower speeds, when the car is cruising to a stop, but the frequency is independent of speed. Noise is most predominant at the lower pressures, under light braking conditions. It also tends to occur more as the braking force is being reduced – as the driver eases off the brake. In addition the frequency will alter slightly as the pressure increases or decreases and will eventually cease if the braking force is increased too high. All these are observable by the driver, and researcher.

Most fixes are implemented around the pad area, and not only because that area is most easy to change, it's because the greatest effect is found there.

It may be shown [1] that in all cases of disc brake noise, the dynamic noise frequency may be related directly to the out-of-plane free mode vibration characteristic of the disc – the diametrical modes. In addition it will be shown that in all cases of brake noise the pad also vibrates. In general noise is related to the friction pair of disc and pad. What one must remember is that in the case of the sliding fist type caliper the carrier bracket needs also to be considered.

It is generally accepted that the higher the coefficient of friction at the pad/disc interface, the greater the tendency will be for the brake to promote noise, hence the saying “a noisy brake is a good brake”. This increase in friction coefficient increases the pad/disc interface force for a given pressure, which in turn results in a greater braking torque. What it does not explain is why there is a greater tendency for the disc to be excited in an out-of-plane mode as a result of this increased braking torque; or that the disc will tend to vibrate with a diametrical mode order. The many experiments of pin on disc [2] and similar work by Earles et. al. [3-5] showed that a spragging affect could cause instability resulting in a variable lateral

force on the disc, if the sprag angle equated to the interface friction coefficient [6]. The mechanism was represented by a semi-rigid strut which was inclined to a rubbing surface and pushed horizontal to the surface. When the inclination angle was set at the “sprag angle” of $\tan^{-1} \mu$ or greater the strut would “dig-in”.

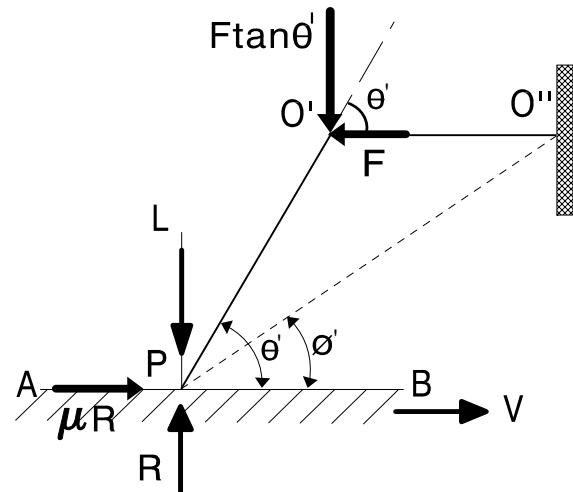

Figure 2 – Sprag-slip model as proposed by Spur.

The normal force to the rubbing surface would then increase until flexure of the system allowed a secondary strut arrangement to be established whereby the sprag angle was reduced, the normal force would reduce and the strut would then continue to slide. Clearly because of the construction of the test rig, and the in-built flexibility of the members, the system was able to establish more than one sprag angle for it to work. The caliper is a similar system with a multiple of “sprag angles” and it is this mechanism in relation to the coefficient of friction at the pad/disc interface which this paper examines.

2. MAIN SECTION

2.1 Historical

It is known that a brake disc will vibrate with a diametrical mode of vibration as shown in Figure 3, whereas a pad will exhibit either a bending or torsional mode as shown in Figure 4.

When a brake system generates noise the disc will exhibit a diametrical mode of vibration and the pad will also vibrate at the abutment faces as shown in Figure 5. The disc may also exhibit a coupled in-plane mode and this should not be disregarded in any investigation/analysis as such coupling is often related to noise.

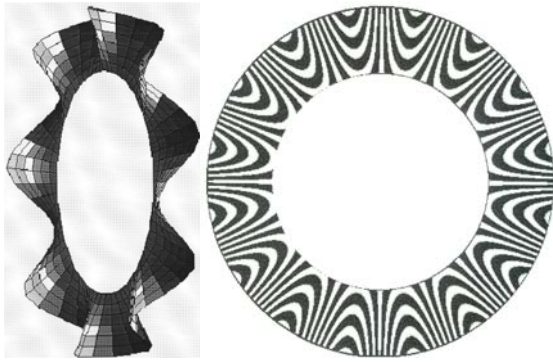

Figure 3 – Left, a disc vibrating in a diametrical mode of vibration. Right, a holographic reconstruction showing the fringe pattern.

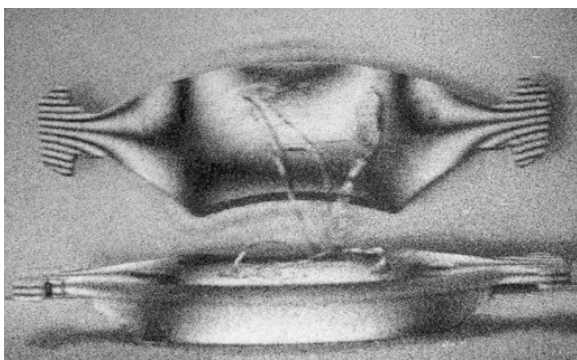
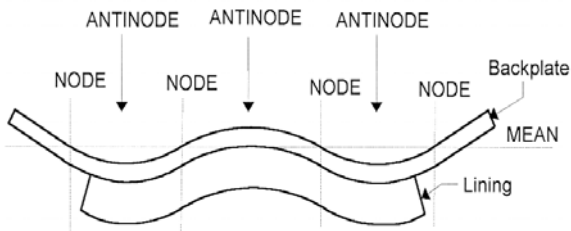
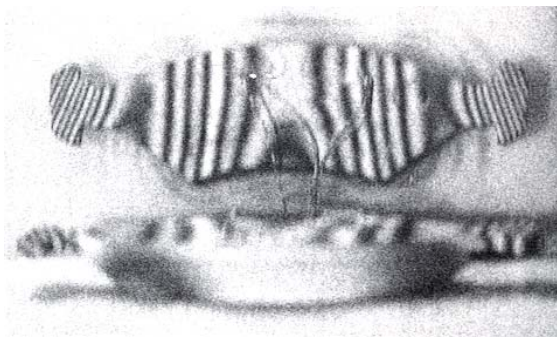

Figure 4 – Top, Holographic reconstruction of a pad bending mode of vibration.
Middle, Diagrammatic representation of the bending mode
Bottom, Holographic reconstruction of a pad torsional mode of vibration.

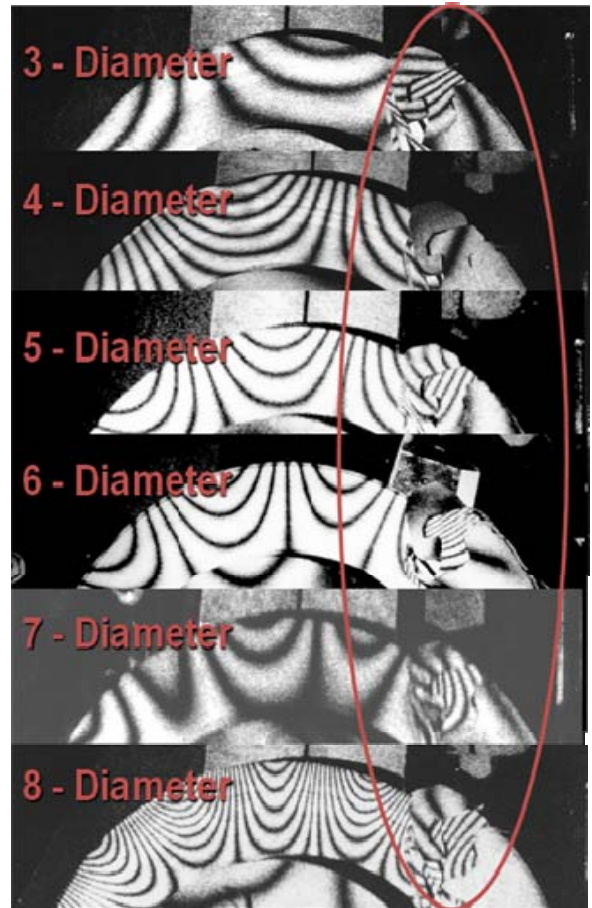

Figure 5 – Modes of vibration and associated trailing end of the pad vibrations.

The arrangement and vibration characteristics are such that the abutment face(s) experience(s) two forces, a normal force due to the disc/pad interface braking load and a lateral force due to the pad vibration. It must be noted that disc in-plane vibration may effect the pad abutment force. The force arrangement may vary dependant on the type/design of pad. For a combined abutment, the temperature and braking load may be important – a single abutment being established before the temperatures and braking force (causing the system to flex) before the second abutment makes contact. Such detail may account for noise occuring during light braking and only on a cold morning.

3.0 ANALYSIS

3.1 Co-Planar Analysis

Figure 6 shows a trailing pad abutment arrangement and Figure 7 the variation in the abutment force over a full cycle, starting at minimum pad displacement. This force will be influenced by the μ /velocity interface friction coefficient characteristic and as such only a nominal gradient is shown in the graph. The least

abutment force will be at maximum velocity which is at minimum pad displacement. The extreme of pad displacement will be maximum force as abutment velocity differential is zero. The interface force then reverses direction. If a co-planar analysis is performed, and considering the reaction force "R" to be varying due to the pad cyclical and reversing abutment force.

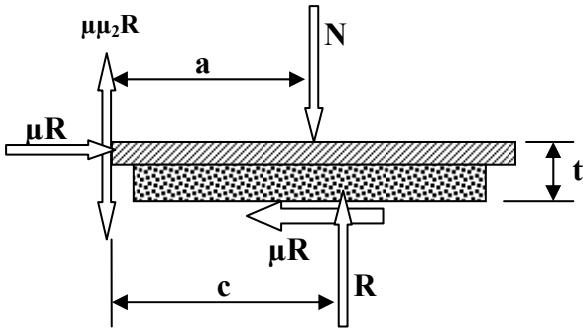

Figure 6 - Free body diagram of brake pad assuming coplanar frictional forces and differing abutment arrangements.

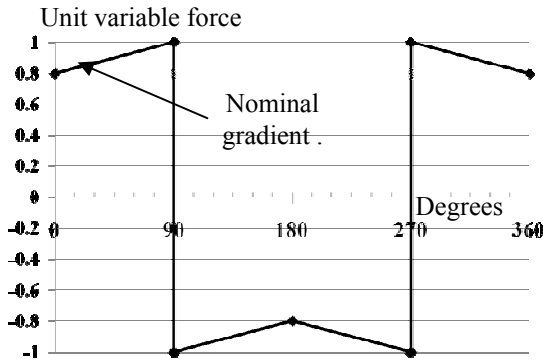

Figure 7 – Representation of variable abutment force at trailing end of pad. The gradients of the graph are due to the μ /velocity characteristics of the interface friction coefficient. At maximum speed differential between pad and abutment the force is at its minimum.

In this case the system is not balanced as "N" is not equal to "R" and the relationship between the two may be determined by resolving forces vertically to give,

If a co-planar analysis of the trailing abutment is performed, with reaction force "R" and abutment force μR and varying force due to the pad vibration abutment force " $\pm R\mu\mu_2$ ",

then

$$R = N \pm \mu \mu_2 R$$

Or

$$\frac{N}{R} = (1 \pm \mu \mu_2) \quad (1)$$

Furthermore, by taking moments about the abutment face "A", equilibrium will be attained if:

$$\mu R t + N a = R c$$

that is

$$\frac{N}{R} = \frac{(c - \mu t)}{a}$$

or

$$c = a \frac{N}{R} + \mu t$$

Substituting for N/R from equation (1) gives

$$c = a(1 \pm \mu \mu_2) + \mu t \quad (2)$$

where

μ = Disc/pad interface friction coefficient.

μ_2 = Pad abutment friction coefficient

t = thickness of pad

and

If the offset of the resultant force "R" to the piston force "N" (c minus a) is δ then from equation (2):

$$\delta = (c - a) = [a(1 \pm \mu \mu_2) + \mu t] - a$$

$$\delta = \mu t \pm a \mu \mu_2 \quad (3)$$

Such analysis is supported by other researchers who have observed that noise propensity reduces as the pad wears [7].

Typically for a high aspect ratio pad

$$a = 70\text{mm}$$

$$\mu = 0.4$$

$$\mu_2 = 0.25 \text{ (Steel on steel)}$$

$$t = 15\text{mm}$$

$$\delta = 6.8 \pm 7$$

$$\delta = + 13.8\text{mm to } -0.2\text{mm}$$

and as μ_2 tends to zero the offset tends to + 6.8mm (μt), leading.

If $\mu = 0.5$ and all other parameters remain the same

$$\delta = 7.5 \pm 8.75$$

$$\delta = + 16.25\text{mm to } -1.25\text{mm}$$

With reference to Figure 8

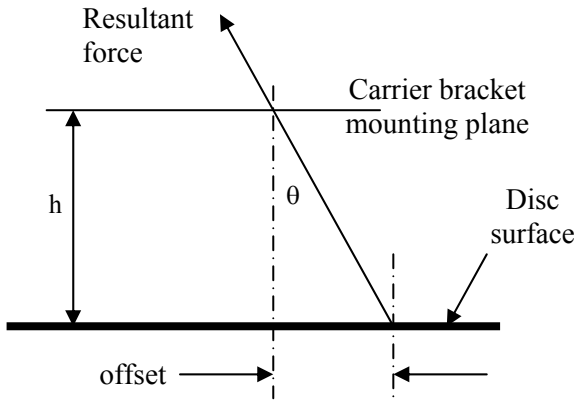

Figure 8 – Sprag angle (θ) relates to the disc/pad friction coefficient where $\theta = \tan^{-1}\mu$.

$$\tan \theta = \mu = \text{offset} / h$$

giving

$$h = \text{offset} / \mu$$

from equation (2) this gives

$$h = t \pm a \mu_2$$

so for the given parameters with $\mu_2 = 0.25$ and considering only the positive as possible:

$$h = 32.5\text{mm}$$

If this height “h” can be related to the brake geometry (for this size of pad), and it is known that noise is an issue, then spragging effect may be the source of noise and may be avoided at the design stage.

3.2 Experimental Investigation of Imposed Offset Centre of Pressure

Earlier experimental investigations on the caliper shown in Figure 1 [8] were carried out to examine the noise propensity of the brake to generate noise with a varying centre of pressure offset. This was undertaken by varying the contact position between the piston and piston pad by using a 0.75mm diameter silver steel wire inserted between the piston face and pad backplate as shown in Figure 9. The offset of the wire was varied 18mm either side of the piston centre, generally in increments of 6mm but in increments of 3mm at critical points. The noise magnitude was recorded at each setting over a range of temperatures and pressures. The test variable parameters were therefore the wire offset, the disc surface temperature and the system pressure with the measured results being the frequency of noise generated, the amplitude and the duration.

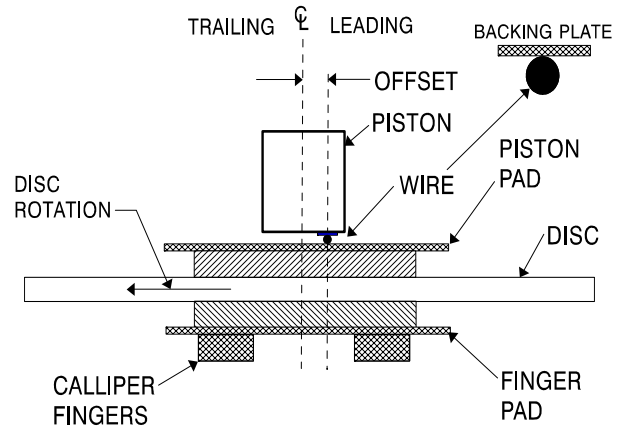

Figure 9 - Diagram showing position of wire to offset contact between piston and pad

A typical set of results from such a test is shown in Figure 10 as a 3D representation and Figure 11 as a 2D. The noise level equivalent ($L_{eq(tot)}$) was calculated to overcome issues of intermittent noise and to provide a single value for one position, for all pressures. It may be seen that with a leading offset of between 12mm and 15mm the system generally generated noise regardless of temperature, the more stable situations being obtained with a zero or trailing offset arrangement. It was further observed that as the temperature reduced, with a resulting increase in coefficient of friction, the critical offset changes from 12mm at 120°C ($\mu = 0.5$ to 0.6) towards 15mm at 60° C ($\mu = 0.6$ to 0.7).

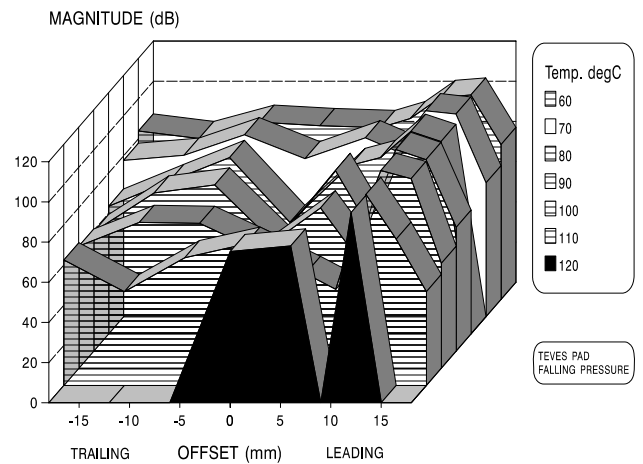

Figure 10 – Offset/ Noise Magnitude ($L_{eq(tot)}$) for a Range of Temperatures

These values compare favourably with the above analyses where the offset “ δ ” was calculated to be from 13.8 ($\mu = 0.4$) to 16mm ($\mu = 0.5$).

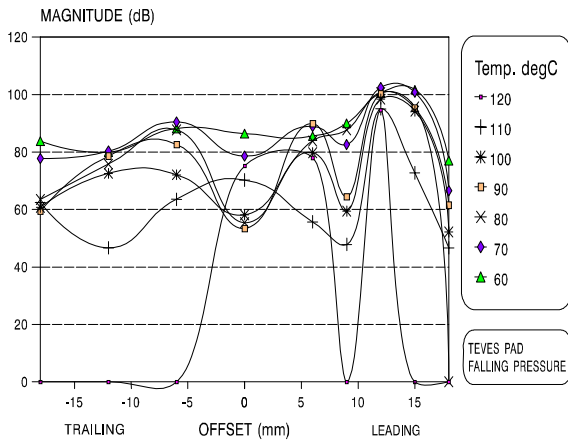

Figure 11 – Offset/Noise Magnitude ($L_{eq(tot)}$) for a Range of Temperatures.

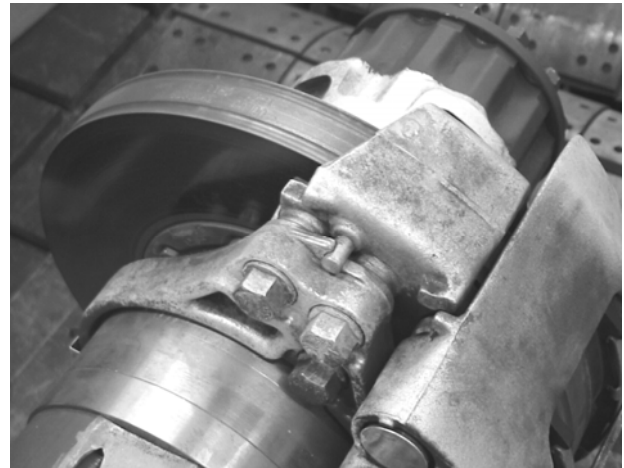

Figure 13 – General view of commercial disc brake

3.3 Case Study

Test Rig Validation - This relation between sprag angle and observation center of pressure (as determined by pad wear) was evaluated against a commercial disc brake as indicated in Figures 12 and 13. The coefficient of friction, μ , for these tests is quoted by the brake manufacturers as 0.34.

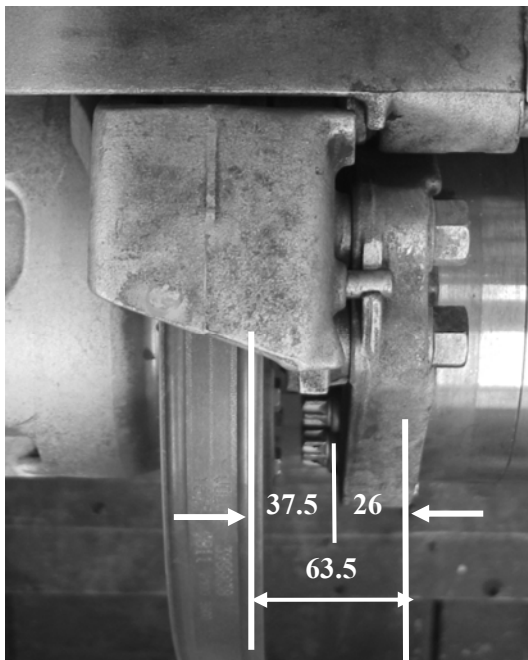
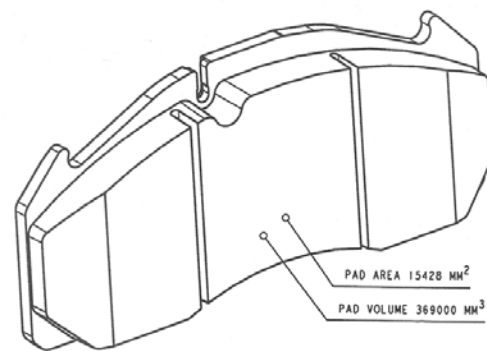

Figure 12 – Side view of commercial disc brake and relevant dimensions.

The distance from the disc face to the caliper mounting bracket face is 37.5mm. This is mounted to an adaptor 26mm thick as shown in Figure 12. The pad is shown in figure 14 with the wear pattern in Figure 15. The pad length was about 200mm and thickness 40mm.



showing mounting bracket.

Figure 14 – General view of pad. Note grooves evident on wear pattern.

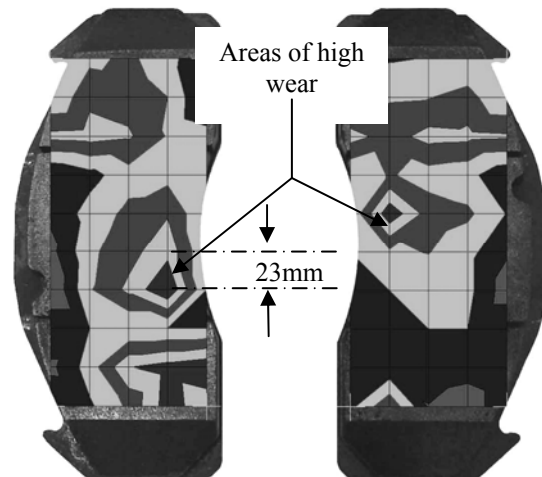

Figure 15 – Wear pattern on surface of pad indicates centre of pressure.

Based on the equation (3)

$$\delta = \mu t \pm a \mu \mu_2$$

then for this pad and friction (assuming μ_2)

$$\delta = (0.34 \times 40) + 100 \times 0.25 \times 0.34$$

$$\delta = 22.1\text{mm}$$

Compare to wear pattern in Figure 15 where offset was 23mm.

and from

$$h = t \pm a \mu_2$$

then in this case

$$h = 40 \pm 100 \times 0.25$$

$$h = 62.5\text{mm}$$

Compare to distance shown in Figure 12 where combined offset was 63.5mm.

3.4 In-plane considerations

If the resultant disc/pad interface force varies according to the equation, $R = N \pm \mu \mu_2 R$, then the braking force and pad abutment force will also vary according to the equation $\mu R = \mu (N \pm \mu \mu_2 R)$. If this is the case then there will be an in-plane cyclical braking/abutment force at the same frequency as the pad vibration. This may result in an in-plane movement of the pad and its abutment face.

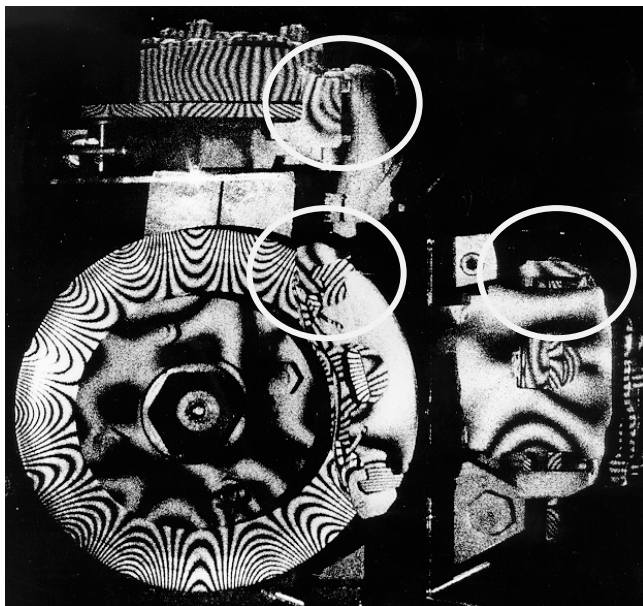

Figure 16 – Reconstructed hologram showing modes of vibration of a brake generating noise at 10,750Hz. Note trailing end of pad vibration and the displacement of the abutment finger (circled). Mirrors show top and side view of brake head. Disc mode 8 diamtrical.

Such a displacement is shown in Figure 16 which indicates pad vibration and abutment finger vibration (circled). In this case the brake was modified with shims to give a trailing abutment only – disc rotation is counter clockwise. It will be noted that the leading

finger shows no displacement as it is not loaded.

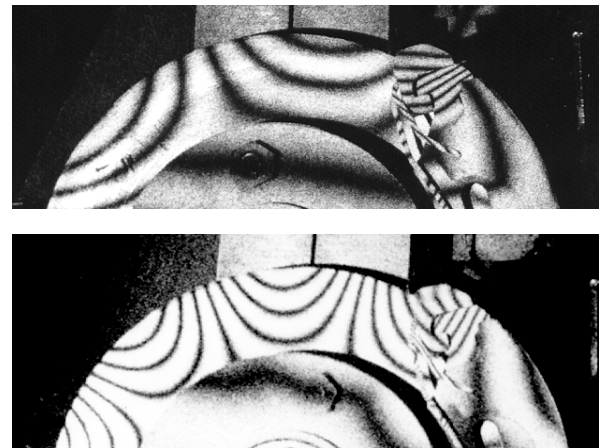

Figure 17 – Similar trailing finger displacement shown with 3 and 5 diametrical modes of vibration.

Using a time series of holograms of the 10,750 Hz mode of vibration, as shown in Figure 16, it was possible to analyse the displacement of the edge of the disc (as seen in the top and right hand images). This allowed the in-plane vibration of the disc to be establish, as shown in Figure 18.

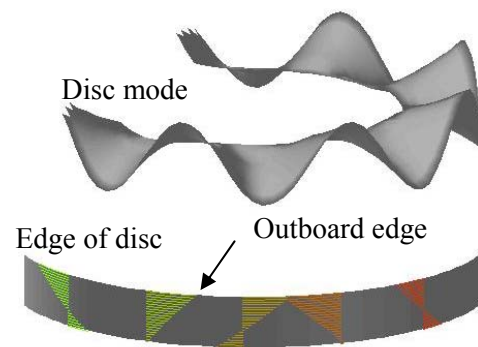

Figure 18 – In-plane vibration of the edge of the disc as shown in Figure 16. Note the upper (outboard edge) displaces more than the lower (inboard) edge. Probably due to finger stiffness.

Figure 18 shows the outboard edge of the disc moving more than the inboard edge. As such the “neutral axis” is off centre as shown. This asymmetry is probably due to the flexure of the trailing finger.

4.0 DISCUSSION

The work has shown that it is possible to calculate the anticipated offset of the reaction “R” from the calliper piston force “N” using a basic co-planar analysis. The analysis demonstrates that if the pad vibrates then the reaction force will need to oscillate along the pad if equilibrium is to be maintained. Two case studies confirm the calculations but many more would be needed to fully understand the relationship between the various friction parameters, pad dimensions and the calliper mounting geometry.

The philosophy and analysis does answer many of the observed noise characteristics:

- Noise disappears as pressure is increased.
Reason is because the pad ceases to vibrate.
- Lubrication on the abutment tends to cure noise.
Reason, the variable abutment oscillating force goes to zero and the resulting offset does not give a spragging angle.
- Nose fix shims work (at high frequencies).
Reason for noise reduction, the pad ceases to vibrate.
- Screwdriver inserted at pad abutment stops noise.
Reason is because pad is prevented from vibrating.
- A high disc/pad interface coefficient of friction is more likely to cause noise.
Reason, it will increase the basic offset and increase the range of reaction force movement along the pad.
- As pad wears there is less propensity to generate noise [4].
Reason, the equation $\delta = \mu t \pm a \mu \mu_2$ indicates that offset "δ" reduces at the pad wears.

The pad vibration induces an in-plane motion of the disc which can be related to the modes of vibration of the disc. Structural integrity of the abutment fingers may reduce the in-plane vibration but the periodic oscillatory reaction force will still be present.

5.0 Conclusions and Recommendations

A noisy brake will have a disc that will exhibit a diametrical mode of vibration and be accompanied by a vibrating pad.

The pad abutment vibration will cause an oscillatory reaction force that will vary between limits about the centre of the pad. The limits are dependant on the pad length and thickness, the disc/pad interface friction coefficient and the pad abutment interface friction coefficient as follows:

$$\delta = \mu t \pm a \mu \mu_2$$

The tendency is for the reaction force offset to be leading.

A high coefficient of friction will increase the basic offset and increase the range of reaction force movement along the pad. This will tend to allow the sprag angle to be more readily established. For this reason a lower disc/pad interface friction coefficient is preferable. A very high friction level may provide for a large leading offset and the associated abutment force may suppress pad vibration and reduce noise propensity. In such cases the braking will be harsh and result in light braking by the driver with a tendency to increase the propensity to generate noise.

The calliper mounting geometry, and indeed the calliper mounting plane, may be a significant feature on allowing a sprag angle to be established. The distance "h" that needs to be avoided from the disc face to the mounting plane is given by the following equation. It is independent of the disc/pad interface friction coefficient:

$$h = t \pm a \mu_2$$

Having a low abutment interface coefficient of friction will tend to reduce noise propensity because the resulting offset will not allow a sprag angle to be established.

Structural integrity of the brake head is important but not at the expense of weight gain. It is required that pad vibration be avoided as this is considered to be the source of noise initiation and noise propensity.

2.1. References

- [1]. Fieldhouse J.D. and Newcomb T.P. "The Techniques of Double Pulsed Holographic Interferometry Applied to the Problems of Noisy Disc brakes" - Vibration and Noise '95 pp 453-457. An international conference on vibration and noise. April 1995, Venice, Italy.
- [2]. Jarvis, R.T. and Mills, B. "Vibrations induced by dry friction." Proceedings of I.Mech.E. 1963-64. Vol. 178 pt 1 No.32, pp 846 – 866
- [3]. Earles, S.W.E. SAE "A mechanism of disc brake squeal." Paper No. 770181, Detroit, 1977.
- [4]. Earles, S.W.E. and Badi, M.N.M."On the interaction of a Two-Pin-Disc System with reference to disc Brake Squeal" SAE Paper No.780331, Detroit 1978.
- [5]. Earles, S.W.E. and Chambers, P.W. "Disc brake squeal noise generation: predicting its dependency on system parameters including damping." International Journal of vehicle Design, vol. 8, nos 4/5/6, pp 538 - 552, 1987.
- [6]. Spurr, R.T.Paper "Brake squeal." No. C95/71, Symposium on Vibration and Noise in Motor Vehicles, I.Mech.E. 1971, pp 13 – 16
- [7]. Liles, G. "An analysis of disc brake squeal using finite element methods." SAE Paper No. 891150, 1989.
- [8]. Fieldhouse JD "A Study of the Interface Pressure Distribution Between Pad and Rotor, the Coefficient of Friction and Caliper Mounting Geometry with Regard to Brake Noise" Brakes 2000 International Conference on Automotive Braking. July 2000 ISBN: 1-86058-261-3, pp 3-18 Pub. MEP.