



Italian Association of Aeronautics and Astronautics

XXII Conference

Napoli, 9-12 September 2013

FLIGHT CONTROL RESEARCH LABORATORY UNMANNED AERIAL SYSTEM WIND SHEAR ON-LINE IDENTIFICATION

C. Grillo^{1*}, D. Murgia and M. Patti

¹DICGIM Department, University of Palermo, 90128 Palermo Italy

*caterina.grillo@unipa.it

1 INTRODUCTION

This work addresses the on line identification of wind shear components which interact with the aircraft, changing both the attitude and the flight path (especially during the critical phases of take off and landing).

Wind shear consists essentially in a spatial and temporal abrupt change of both wind speed and direction. This general definition, groups a set of atmospheric phenomena that give rise to the phenomenon as Microburst, Gust front, Sea breeze and Flow past terrain.

The state of the art, in research and identification of wind shear, is related to the instrumental measurements carried out by land based locations near airports or on board the aircraft, such as doppler radar. However, the use of these detection techniques, is severely limited, as they are related to the morphology of the territory and to the precision of the instrumentation. Therefore only the average speeds of the components of the wind are measured.

To determine the wind speed with increasing height, there are two main techniques the Log law and the Power law. Both of these laws have derived by using semi-empirical relations since they come from solution of simplified cases of Navier-Stokes equations and from field experiences. Both laws, however, are dependent by the coefficient of roughness of the ground. Usually [1], the wind shear is assumed to be same as the atmospheric planetary boundary layer. This method is based on a prior knowledge of the velocity profile and intensity of the wind. The wind shear, instead, is a phenomenon in which the velocity components of the wind, have got strong gradients in the time and space and then the behavior is characterized by the accelerations.

In [2], the effects of wind shear on aircraft motion and aerodynamics are modeled using the techniques described in Frost and Bowles [3](1984), Stengel [4](1990) and Oseguera and Bowles,[5] (1988).

In [6], to design the longitudinal guidance and control system for an aircraft, able to compensate wind shear effects, an Adaptive Back Stepping control law is implemented. The wind shear model is based on an available set of experimental data collected during a real situation in presence of wind shear [7].

In this paper, the mathematical model of aircraft and wind shear in the augmented state space is built taking into account the acceleration components of the wind, without any restrictive assumption on the dynamic of the wind shear.

Because of the strong velocity gradients characterize the wind shear it was decided to study only the components of acceleration of the wind. Since either longitudinal, normal or angular

accelerations due to wind shear have been included into the equations of motion. So the space state dimensions is increased by the number of wind shear components.

The identification problem addressed in this work has been solved by using the Filter error method approach. Actually ,such a stochastic processes, based on the use of the Extended Kalman Filter for both state estimation and output variables reconstruction, seeks to minimize the error between instrumental measurements and estimated outputs [2],[8].

An algorithm has been implemented to reconstruct the evolution of turbulence starting from instrumental measurements. In order to reconstruct the interference signals onboard, an Extended Kalman Filter has developed. This one, by using the parameters which have been determined by solving the identification problem, affords to estimate onboard either aircraft state or turbulence , with significant savings in terms of time and computing resources.

2 AIRCRAFT DYNAMIC MODEL

In the classical equations for longitudinal dynamics of aircraft, the state space vector is

$$x = [V \ \alpha \ q \ \theta]^T \quad (1)$$

where the elements are the airspeed, the angle of attack, the pitch rate and the flight attitude respectively.

The classical equations consider the aircraft in still air [9]. To describe the problem of an aircraft in the turbulent air, we need an additional set of equations. Because of the strong velocity gradients in space and time typical of wind shear induce accelerations on the aircraft such equations are obtained by modeling wind shear effects as external force and moments applied on the aircraft

$$F_e = \begin{bmatrix} m \dot{u}_g \\ m \dot{w}_g \\ I_y \dot{q}_g \end{bmatrix} \quad (2)$$

Where $\dot{V}_g = [\dot{u}_g \ \dot{w}_g \ \dot{\omega}_g]^T$ are the linear acceleration (along x and z) and the rotational acceleration respectively. In this way no assumptions about the dynamics of the wind shear has been made, but only on the effects that this induces on the aircraft.

With this assumption, the aircraft equations of motion are defined in the form:

$$\dot{\xi}(t) = [\dot{x}, \dot{V}_g]^T = f[x(t), u(t), \beta] + \dot{V}_g \quad (3)$$

$$y(t) = g[x(t), u(t), \beta] + \dot{V}_g \quad (4)$$

The above equations are defined as:

$$\dot{V} = -\frac{\bar{q} * S}{m} * C_D + g \sin(\alpha - \theta) + \frac{T}{m} \cos \alpha + \dot{u}_g \cos \alpha + \dot{w}_g \sin \alpha \quad (5)$$

$$\dot{\alpha} = -\frac{\bar{q} * S}{m * V} * C_L + q + \frac{g}{V} * \cos(\alpha - \theta) - \frac{T}{m * V} \sin(\alpha + \alpha_t) - \frac{\dot{u}_g \sin \alpha}{V} + \frac{\dot{w}_g \cos \alpha}{V} \quad (6)$$

$$\dot{q} = \frac{\bar{q} * S * c}{I_y} * C_m + \dot{q}_g \quad (7)$$

$$\dot{\theta} = q \quad (8)$$

$$\ddot{q}_g = 0 \quad (9)$$

$$\ddot{V}_{gx} = 0 \quad (10)$$

$$\ddot{V}_{gz} = 0 \quad (11)$$

where:

$$\bar{q} = \frac{1}{2} \rho * V^2 \quad (12)$$

$$C_D = C_{D0} + C_{DV} * V + C_{D\alpha} * \alpha + C_{D\delta_e} * \delta_e \quad (13)$$

$$C_L = C_{LV} * V + C_{L\alpha} * \alpha + C_{L\dot{\alpha}} * \dot{\alpha} + C_{Lq} * q + C_{L\delta_e} * \delta_e \quad (14)$$

$$C_m = C_{m0} + C_{mV} * V + C_{m\alpha} * \alpha + C_{m\dot{\alpha}} * \dot{\alpha} + C_{mq} * q + C_{m\delta_e} * \delta_e \quad (15)$$

Moreover T is the thrust.

Notice that derivatives like C_{DV} are defined by $\frac{\partial C_D}{\partial V} \left[\frac{\text{second}}{\text{meter}} \right]$.

The on board instruments measure the outputs vector $Y = [V \alpha q \theta \dot{q} a_x a_z]_m$. In the output equations, which describe analytically the outputs of the system, $[V \alpha q \theta]$ is equal to the state vector and $\dot{q} a_x a_z$ are defined as:

$$\dot{q}_m = \frac{\bar{q} * S * c}{I_y} * C_m + \dot{q}_g \quad (16)$$

$$a_{xm} = \frac{\bar{q} * S}{m} * C_x + \frac{F_e}{m} + \dot{u}_g \quad (17)$$

$$a_{zm} = \frac{\bar{q} * S}{m} * C_z + \dot{w}_g \quad (18)$$

where C_x and C_z are referred to the body reference frame.

Taking into account the above equations, the state vector is inclusive of both the state variables of the aircraft and of the wind shear components. The expanded state is defined as:

$$x = [V \alpha q \theta \dot{u}_g \dot{w}_g \dot{q}_g]^T \quad (19)$$

3 IDENTIFICATION PROCEDURE

As it is known, real processes and experimental data are affected by measurement noise in the sensors and modeling errors, therefore unmodeled dynamics have to take into account. So to solve the identification problem, addressed in the present work, a procedure of estimation based on statistical criteria has to be used. The Filter Error Method [10] approach have been used to estimate unknown parameters, because of such a method takes into account both the measurement noise and the system noise.

In the theory of parameter estimation it is required to deduce the values of the unknown parameter vector, using a database of measurements, that are taken from the same data sample.

A likelihood function, in this theory, is defined as:

$$p(z|\theta) = \prod_{k=1}^N p(z_k|\theta) \quad (20)$$

where

- z is the measurement sampled
- $\theta = [\beta, F]$ is the unknown parameter vector, it includes the parameters of the aircraft β and the components of the process noise covariance matrix (Q).
- N is the number of samples analyzed
- $p(z|\theta)$ is the probability of z given θ .

In such a theory, the cost function is defined as:

$$J(z|\theta, R) = -\ln p(z|\theta) \quad (21)$$

The Maximum Likelihood try to select, in a permissible range, the value of θ which minimizes $J(z|\theta, R)$. Equation (21) features a non-linear optimization problem, usually solved by using the Gauss-Newton method, which leads to a system of linear equations, which can be represented in general form as follows:

$$\theta_{i+1} = \theta_i - F^{-1}G \quad (22)$$

where F is the Fisher information matrix and G is the gradient vector, defined as:

$$F = \sum_{k=1}^N \left[\frac{\partial y(t_k)}{\partial \theta} \right]^T R^{-1} \left[\frac{\partial y(t_k)}{\partial \theta} \right] \quad (23)$$

$$G = -\sum_{k=1}^N \left[\frac{\partial y(t_k)}{\partial \theta} \right]^T R^{-1} [z(t_k) - y(t_k)] \quad (24)$$

with R the measurement noise covariance matrix.

Noise with zero mean and diagonal matrix R , has been considered (i.e. the components of noise vector are uncorrelated).

As previous stated, equations (5-18) describe an non-linear dynamic model of the aircraft, moreover the process under examination contains stochastic inputs not directly measurable (i.e. wind shear). An Extended Kalman Filter (EKF), through knowledge of the outputs, is implemented to propagate the state of the system.

Because of the characteristics of the on board instrumentation are known, the measurement noise covariance matrix (R) is considered to be known and constant. The tuning of the filter is made through the identification of the process noise covariance matrix (Q).

The Extended Kalman filter equations are:

$$\tilde{y}(k) = g[\tilde{x}(k), u(k), \beta] \quad (25)$$

$$K(k) = \tilde{P}(k)C^T [C\tilde{P}(k)C^T + R(k)]^{-1} \quad (26)$$

$$\hat{x}(k) = \tilde{x}(k) + K(k)[z_k - \tilde{y}(k)] \quad (27)$$

$$\hat{P}(k) = [I - K(k)C]\tilde{P}(k)[I - K(k)C]^T + K(k)R(k)K^T(k) \quad (28)$$

where:

- \tilde{y} is the predicted output variables
- g is a nonlinear function
- \tilde{x} and \hat{x} denote the predicted and corrected state vector
- u the average of the control input
- $[z_k - \tilde{y}(k)]$ is the residuals

- K is the Kalman filter gain matrix
- \hat{P} is the covariance matrix of the state-predictions error

Since in Kalman Filtering theory, the process noise covariance matrix (Q) is usually chosen as diagonal matrix, the hypothesis that the components of the noise vector are statistically mutually independent, has been adopted.

With the above introduced hypothesis, the parameters vector θ is constituted through the aircraft parameters

$$\beta = [c_{DO} \ c_{D\alpha} \ c_{D\delta_e} \ c_{L\alpha} \ c_{L\dot{\alpha}} \ c_{Lq} \ c_{L\delta_e} \ c_{M0} \ c_{M\alpha} \ c_{M\dot{\alpha}} \ c_{Mq} \ c_{M\delta_e} \ c_{DV} \ c_{LV} \ c_{MV}]^T \quad (29)$$

and the diagonal terms of Q

$$diag(Q) = [F_{11} \ F_{22} \ F_{33} \ F_{44} \ F_{55} \ F_{66} \ F_{77}]^T \quad (30)$$

So it is defined as:

$$\theta = [\beta, \ diag(Q)] \quad (31)$$

Because the parameter vector β of the aircraft is known, the identification algorithm allows to estimate the process noise covariance matrix components.

So, the update parameters vector is:

$$\begin{bmatrix} c_{DO} \\ c_{D\alpha} \\ c_{D\delta_e} \\ c_{L\alpha} \\ c_{L\dot{\alpha}} \\ c_{Lq} \\ c_{L\delta_e} \\ c_{M0} \\ c_{M\alpha} \\ c_{M\dot{\alpha}} \\ c_{Mq} \\ c_{M\delta_e} \\ c_{DV} \\ c_{LV} \\ c_{MV} \\ F_{11} \\ F_{22} \\ F_{33} \\ F_{44} \\ F_{55} \\ F_{66} \end{bmatrix}_{i+1} = \begin{bmatrix} c_{DO} \\ c_{D\alpha} \\ c_{D\delta_e} \\ c_{L\alpha} \\ c_{L\dot{\alpha}} \\ c_{Lq} \\ c_{L\delta_e} \\ c_{M0} \\ c_{M\alpha} \\ c_{M\dot{\alpha}} \\ c_{Mq} \\ c_{M\delta_e} \\ c_{DV} \\ c_{LV} \\ c_{MV} \\ F_{11} \\ F_{22} \\ F_{33} \\ F_{44} \\ F_{55} \\ F_{66} \end{bmatrix}_i + \begin{bmatrix} 0 \\ 0 \\ 0 \\ 0 \\ 0 \\ 0 \\ 0 \\ 0 \\ 0 \\ 0 \\ 0 \\ 0 \\ 0 \\ 0 \\ 0 \\ \Delta_{11} \\ \Delta_{22} \\ \Delta_{33} \\ \Delta_{44} \\ \Delta_{55} \\ \Delta_{66-i} \end{bmatrix} \quad (32)$$

As explained above, the algorithm reduces errors between the estimated and measured outputs by manipulating only the values of Q .

The identification process is performed by the following items:

- Choose suitable initial values for the unknown parameters
- Computation of Kalman gain matrix

- Estimation and propagation of the state through the EKF
- Updating θ by the Gauss-Newton method
- Computation of a new Kalman gain matrix with the updated parameters θ

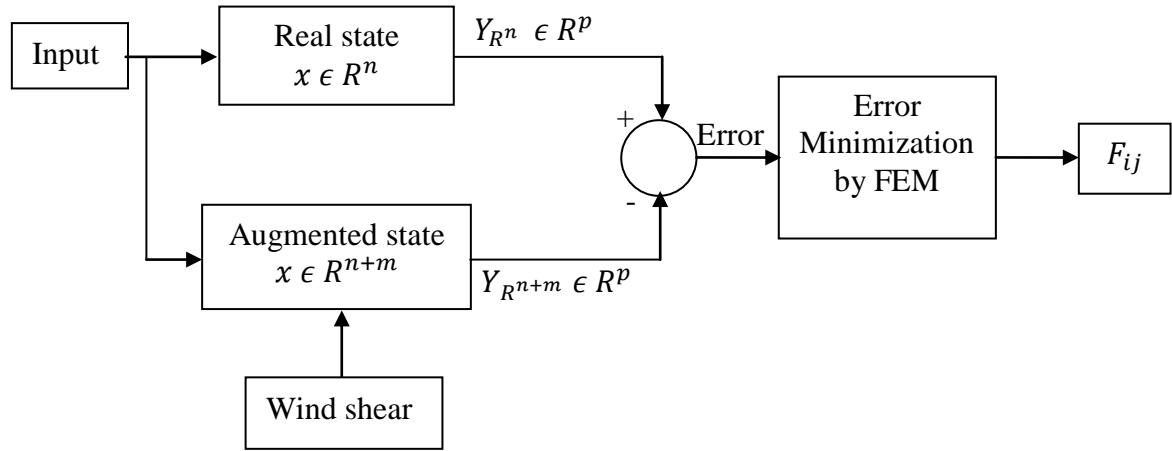

Figure 1: Block schematic of identification algorithm

where n is the state vector dimension, $n+m$ is the augmented state vector dimension and p is the output vector dimension.

Once the off-line identification of the process noise covariance matrix Q is performed, known the measurement noise covariance matrix (R), the Extended Kalman Filter is tuned and the online identification wind shear is achieved.

4 RESULTS

As previous stated the implemented on line Wind Shear identification algorithm has been performed by means of the research aircraft FCRL (Flight Control Research Laboratory) used for the Italian National Research Project PRIN2008 .The studied vehicle, a Preceptor N3-Ultra-PUP, is an unpressurized 2 seats, 427 Kg maximum take of weight aircraft. It is equipped with a research avionic system composed by low cost sensors and computers and their relative power supply subsystem

The geometric and aerodynamic characteristics of the aircraft, are summarized in table 1.

$m = 427 [Kg]$	$c_{D0} = 0.0665$	$c_{L\delta_e} = 0.1561$	$c_{DV} = 0$
$I_y = 694.41 [Kg * m^2]$	$c_{D\alpha} = 0.4807$	$c_{M0} = -0.0757$	$c_{LV} = 0$
$S = 11.14 [m^2]$	$c_{D\delta_e} = 0.0082$	$c_{M\alpha} = -1.2833$	$c_{MV} = 0$
$c = 1.20 [m]$	$c_{L\alpha} = 3.9977$	$c_{M\dot{\alpha}} = -0.0816$	
$n_{max} = 3.8$	$c_{L\dot{\alpha}} = 0.0317$	$c_{Mq} = -0.2131$	
	$c_{Lq} = 0.1360$	$c_{M\delta_e} = -0.3983$	

Table 1: The geometric and aerodynamic characteristics of the aircraft

As previous stated, the first step of the online determination of wind shear components is performed by off-line identification of the vector θ . Because of, the parameter vector β of the aircraft is known the identification process performs an estimation of the process noise

covariance matrix components (Eq.32), using a database of measurements. The designed algorithm employees the known measurement noise covariance matrix (R):

$$diag(R) = [0.02; 1 * 10^{-7}; 1 * 10^{-6}; 1 * 10^{-4}; 1 * 10^{-4}; 1 * 10^{-4}; 1 * 10^{-4}]^T$$

Output sensors are characterized by Gaussian white noise, whose standard deviations values are given in table 2

$\sigma_Y^2 = 1 * 10^{-8}$	$\sigma_{x_e}^2 = \sigma_{z_e}^2 = 1$
$\sigma_q^2 = 1 * 10^{-6}$	$\sigma_V^2 = 0.009$
$\sigma_{\dot{q}}^2 = 1 * 10^{-6}$	$\sigma_{a_x}^2 = \sigma_{a_z}^2 = 1 * 10^{-4}$
	$\sigma_{\alpha}^2 = 1 * 10^{-7}$

Table 2: Sensors output variance

The obtained components of process noise covariance matrix are:

$$diag(Q) = [-21.60; -18.62; -26.28; -24.46; 28.67; 13.38; -48.70]^T$$

Once the Q matrix has been determined the online determination of wind shear components is carried out by using the procedure described in paragraph 3.

A flight database was obtained through simulation because no experimental data are available in the presence of wind shear.

For these reasons, a simulator is designed, in which the wind shear has been introduced.

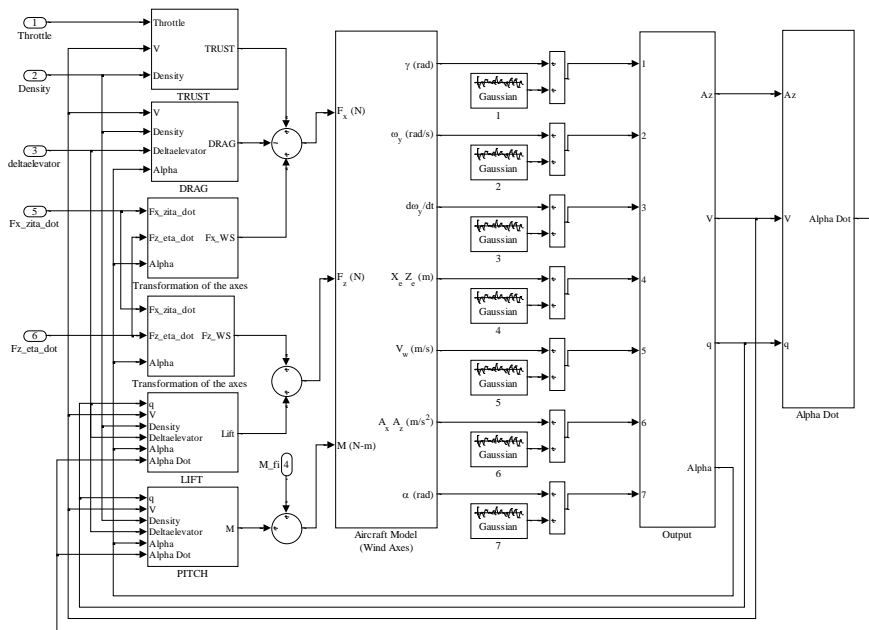

Figure 2 : Simulation Scheme

Simulations have been performed by choosing a flight altitude $h = 500 [m]$ and a rectilinear horizontal flight condition with $V = 27 \frac{[m]}{[s]}$.

To cope with the strong gradient in space and time of the wind shear components, it has been introduced as not handled square pulses wave input having a very short pulse width. Figures (3-5) show the comparison between estimated wind shear components and the noise introduced into the system.

In figure 3 the disturbance is a square waves pulses with 10 seconds period and 1.5 seconds pulse width, in figure 4 this one has 10 seconds period and 0.2 seconds pulse width and in figure 5 this one has 5 seconds period and 0.1 seconds pulse width.

The obtained results show that the designed and tuned identification algorithm, estimates the wind shear components with excellent results. In fact the maximum error is $0.03 \left[\frac{m}{s^2} \right]$ and it affects the gust acceleration along x. The minimum error is $0.004 \left[\frac{rad}{s^2} \right]$ and it affects the gust rotational acceleration.

It is noticeable that the maximum error (negligible) is obtained when the signal to be estimated follow a constant trend, this condition is, as well known, the worst condition for the estimation. Therefore, it is important to note that even if usually, the square wave reconstruction is affected by delays and errors due to the different dynamic between the phenomenon and the filter, the proposed algorithm reproduces the shape of the wave perfectly and the delays are negligible

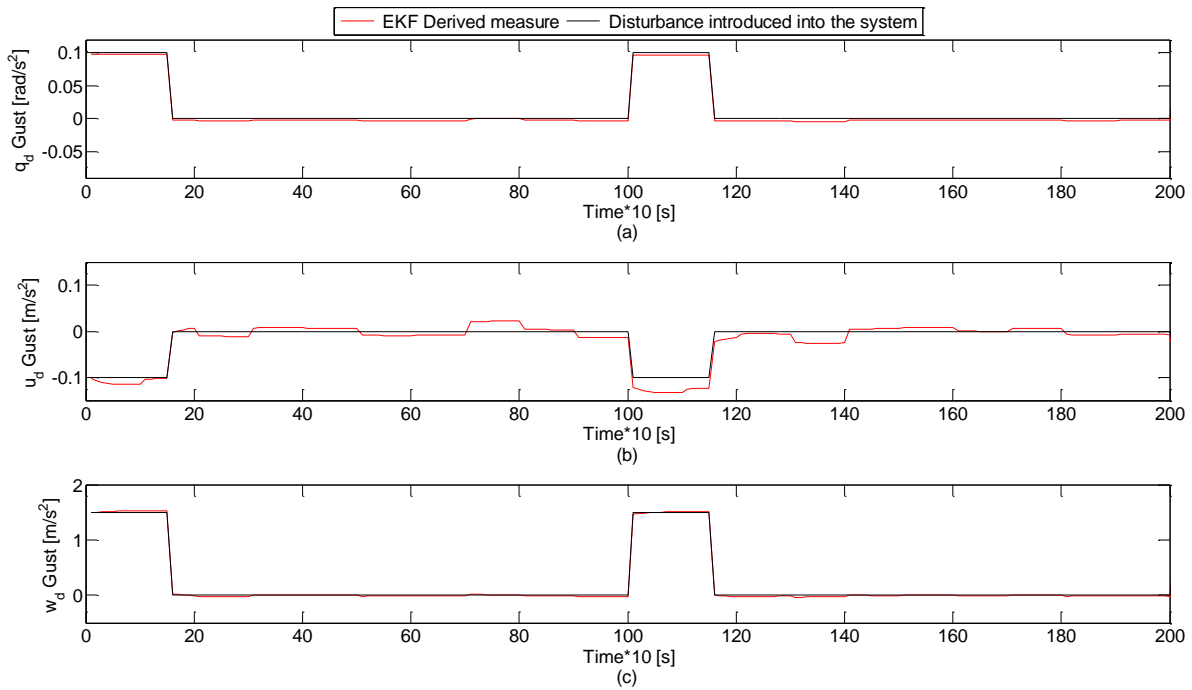

Figure 3: Reconstruction of wind shear components. Square wave pulses with 10 seconds period and 1.5 seconds pulse width. (a) Angular Gust Acceleration, (b) Linear Gust Acceleration along x and (c) Linear Gust Acceleration along z

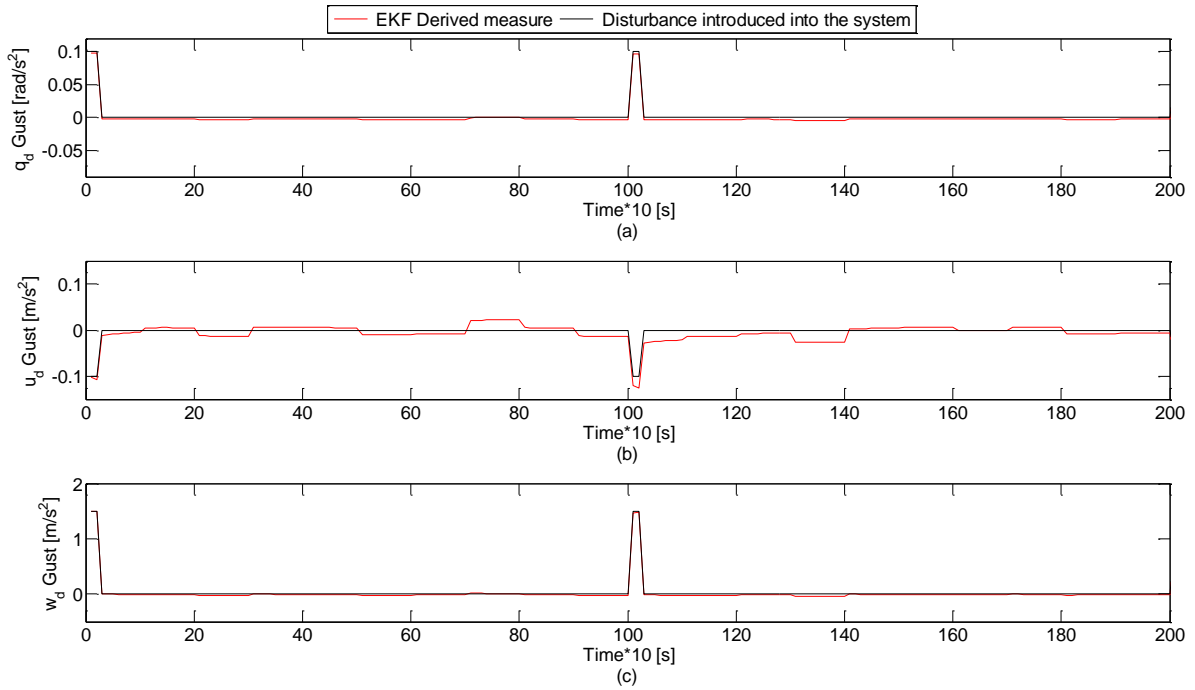

Figure 4: Reconstruction of wind shear components. Square wave pulses with 10 seconds period and 0.2 seconds pulse width. (a) Angular Gust Acceleration, (b) Linear Gust Acceleration along x and (c) Linear Gust Acceleration along z

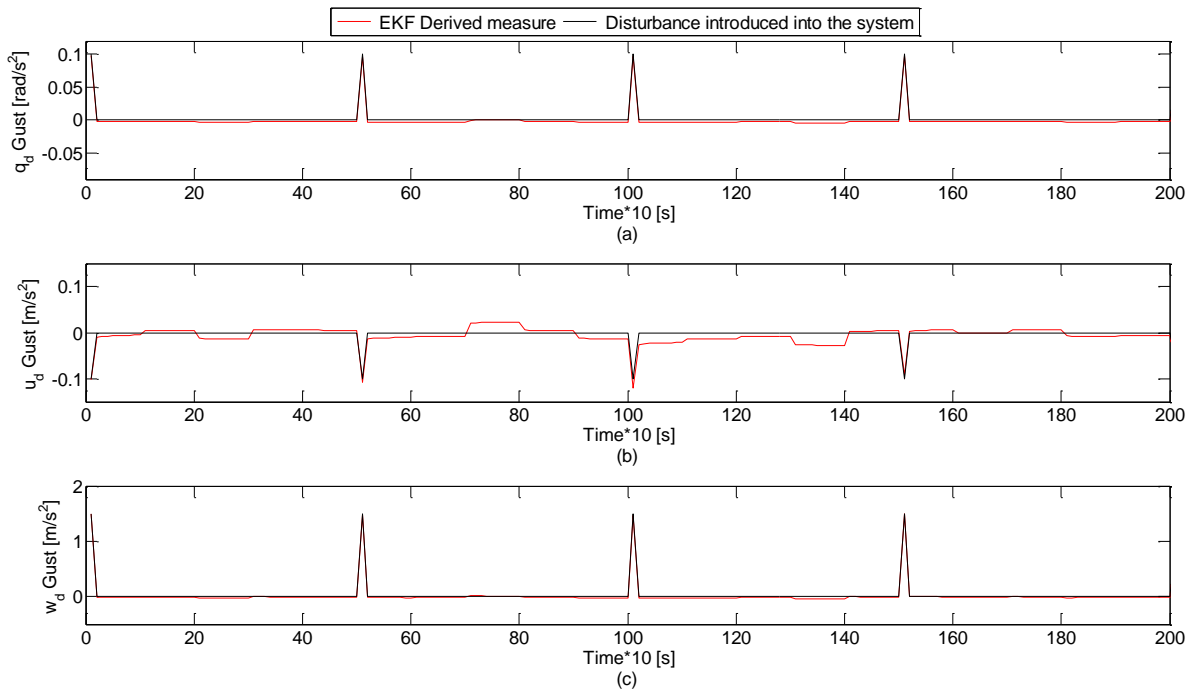

Figure 5: Reconstruction of wind shear components. Square wave pulses with 5 seconds period and 0.1 seconds pulse width. (a) Angular Gust Acceleration, (b) Linear Gust Acceleration along x and (c) Linear Gust Acceleration along z

5 CONCLUSION

The obtained results show that both shape and intensity of the wind shear components are estimated with the utmost precision. Furthermore the aircraft state estimation is performed with negligible errors.

Moreover they attest the feasibility of the tuned up algorithm. In fact it is possible, by using a few numbers of low cost sensors, to estimate with a noticeable accuracy the augmented state vector. Besides a very short computation time is required to perform the augmented state estimation even by using low computation power. Therefore the implemented algorithm is very suitable for the UAS characteristics. The estimated variables may be used to the implementation of the guidance and control algorithms taking into account the atmospheric turbulence. Wind shear detection on-line could contribute to an efficient safe insertion of UAS in the Civil Air Transport System. In fact it is possible an autonomous reactive motion planning where the vehicle's control system detects previously unknown disturbance, designs a new path in real time, and continues the mission.

Besides, by using the tuned up procedure to determine the process noise covariance matrix in case of failure on one or more control devices, it will be possible the reconfiguration of the control system in order to ensure fault-tolerant operations.

Further developments of the present research, will be devoted to the online identification of the full set of wind shear components by using a six degree of freedom model of the studied aircraft.

6 ACKNOWLEDGEMENTS

This paper has been realized with the financial support of the Italian Ministry of University and Scientific Research (MIUR) in the context of PRIN 2008

REFERENCES

- [1] E. Fedorovich, R. Conzemius. Effects of wind shear on the atmospheric convective boundary layer structure and evolution. *Acta Geophysica*, **Volume 56**, issue 1, pp. 114-141 (2008).
- [2] S. S. Mulgund, R.F Stengel. Optimal Non linear Estimation for Aircraft Flight Control in Wind Shear. *Automatica*, **Volume 32 N.1**, pp.3-13 (1996).
- [3] W. Frost, R. L. Bowles. Wind shear terms in the equations of aircraft motion. "*Journal of Aircraft*", **Volume 21, No. 11**, pp. 866-872 (1984).
- [4] R. F. Stengel, Course Notes for MAE 566, Aircraft Dynamics, Princeton University. (1990).
- [5] R. M. Oseguera, R. L. Bowles. A simple, analytic 3-dimensional downburst model based on boundary layer stagnation flow. *NASA TM 100632*, (1988).
- [6] P. Baldi, P. Castaldi, N. Mimmo, A. Torre and S. Simani. A New Longitudinal Flight Path Control with Adaptive Wind Shear Estimation and Compensation in " *Proceeding of 50th IEEE Conference on Decision and Control and European Control Conference (CDC-ECC)*", Orlando, FL, USA, (2011).
- [7] D. Mc Lean. "Automatic Flight Control Systems". Prentice Hall Int., London, (1990).
- [8] C. Grillo, F.P. Vitrano. State Estimation of a Nonlinear Unmanned Aerial Vehicle Model Using an Extended Kalman Filter in " *Proceeding of 15th AIAA International*

Space Planes and Hypersonic Systems and Technologies Conference", Dayton, Ohio (2008).

[9] B. Etkin. "Dynamics of Atmospheric Flight". Dover Publications, (2005).

[10] V. Ravindra, Jategaonkar. " Flight Vehicle System Identification - A Time Domain Methodology". American Institute of Aeronautics and Astronautics, **Volume 216**, (2009).