

Provided for non-commercial research and education use.
Not for reproduction, distribution or commercial use.

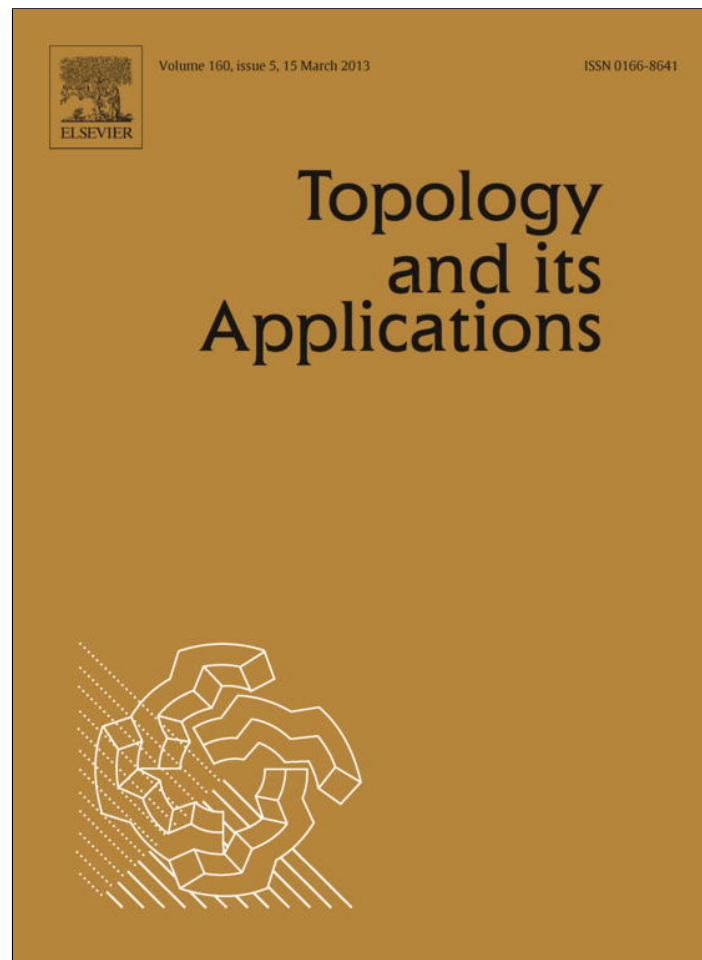

This article appeared in a journal published by Elsevier. The attached copy is furnished to the author for internal non-commercial research and education use, including for instruction at the authors institution and sharing with colleagues.

Other uses, including reproduction and distribution, or selling or licensing copies, or posting to personal, institutional or third party websites are prohibited.

In most cases authors are permitted to post their version of the article (e.g. in Word or Tex form) to their personal website or institutional repository. Authors requiring further information regarding Elsevier's archiving and manuscript policies are encouraged to visit:

<http://www.elsevier.com/copyright>



Contents lists available at SciVerse ScienceDirect

Topology and its Applications

www.elsevier.com/locate/topol



On the 1-handles of the product $V^3 \times B^n$ for a simply connected open 3-manifold V^3



Valentin Poénaru^{a,b,1}, Corrado Tanasi^{a,b,*}

^a Université de Paris Sud Mathématiques, Bât. 425, 91405 Orsay, France

^b Dipartimento di Matematica e Informatica, via Archirafi 34, 90123 Palermo, Italy

ARTICLE INFO

Article history:

Received 14 December 2011

Received in revised form 28 January 2013

Accepted 30 January 2013

MSC:

57M07

57M60

57N65

Keywords:

Dehn exhaustibility

Geometrically simply connection

Quasi-simply filtered

O(i) movements

ABSTRACT

Although $\pi_1^\infty V^3$ is an obstruction for killing stably the 1-handles of an open simply connected 3-manifold V^3 , one can always get rid of the 1-handles of $V^3 \times B^n$, for high enough n , at the price of a certain nonmetrizable slackening of the topology.

© 2013 Elsevier B.V. All rights reserved.

1. Introduction

One of the roots for the present work is the first author's paper [8]. It will be helpful to start by giving a modern, up to date version, of what was going on in that old paper. But for that, first we need a definition. A smooth manifold $M^{n \geq 3}$ is said to be **Dehn exhaustible** (DE) if for every compact $k \subset M^n$ there is commutative diagram, with j an inclusion,

$$\begin{array}{ccc}
 k & \xrightarrow{j} & P^n \\
 & \searrow & \swarrow g \\
 & & M^n
 \end{array}
 \tag{1}$$

such that P^n is a compact simply connected smooth n -manifold and g is a (smooth) immersion which satisfy the following Dehn-type condition:

$$jk \cap \{ \text{the set } M_2(g) \subset P^n \text{ of the double points of } g \} = \emptyset.
 \tag{2}$$

With this, what the modern version of [8] says is the following

* Corresponding author at: Dipartimento di Matematica e Informatica, via Archirafi 34, 90123 Palermo, Italy.

E-mail addresses: valpoe@hotmail.com (V. Poénaru), corrado.tanasi@unipa.it (C. Tanasi).

¹ Partially supported by NSF grant DMS-0071852.

Proposition A. *Let M^n be an open smooth n -manifold such that, for some $p \geq 1$, the $M^n \times B^p$ is geometrically simply connected (GSC). Then M^n is DE.*

The notion GSC stems from differential topology, where it means the existence of a handlebody decomposition where the 1-handles and 2-handles are in canceling position. But this same notion also makes sense for cell-complexes, in general, see [7].

Corollary B. *Under the conditions of Proposition A, if $n = 3$, then*

$$\pi_1^\infty M^3 = 0.$$

This is actually what [8] proves, but between the lines, the proof of Proposition A should be readable there too. Having these things in the background, we will describe next what the present paper does.

Theorem C. *Let V^3 be any open simply-connected 3-manifold, and let also $m \in \mathbb{Z}_+$ be large enough. There is then an infinite collection of smooth $(m + 3)$ -manifolds, all of them non-compact, with very large boundary, connected by a sequence of smooth embeddings*

$$X_1 \subset X_2 \subset X_3 \subset \dots \tag{3}$$

such that

- 1) X_1 is GSC and each of inclusion in (3) is either an elementary Whitehead dilatation or the addition of a handle of index $\lambda > 1$.
- 2) When one considers the union of the objects in (3), endowed with the **weak topology**, call this new space $\varinjlim X_i$, then there is a continuous bijection

$$\varinjlim X_i \xrightarrow{\psi} V^3 \times B^m. \tag{4}$$

Notice also there in the context of Theorem C there is no reasonable topology which is usable other than weak one. The reader is reminded that in the weak topology, a set $F \subset \varinjlim X_i$ is closed iff all the $F \cap X_i$ are closed. Also, the inverse of ψ is not continuous here; would it be, this would certainly contradict [8], since V^3 may well be the Whitehead manifold Wh^3 . This, *via* Brouwer, also means that $\varinjlim X_i$ cannot be a manifold (which would automatically be then GSC coming in conflict with Proposition A). Also, exactly for the same reasons why $\varinjlim X_i$ is not a manifold, it is **not a metrizable space** either.

In the context of formula (4) the only place where things go wrong, i.e. where the inverse map of ψ fails to be continuous and where $\varinjlim X_m$ is not a manifold, is a codimension one smooth PROPER $\Sigma(\infty) \subset V^3 \times \partial B^m$. This BAD LOCUS $\Sigma(\infty)$ is quite well defined in terms of Theorem I from [15].

Actually, in the main body of the present paper, it is not V^3 which occurs but a variant of it V_h^3 , the “ V^3 with very many holes”, but this is a rather irrelevant technically which we will skip over in this introduction.

In order to explain the interest of Theorem C, let us go back to the context of DE. From this concept, S. Brick, M. Mihalik and J. Stallings [1,16] have abstracted the notion QSF (quasi-simply filtered). Here is the change from DE to QSF. In the context of (1) M^n becomes a locally compact simplicial complex X and, most importantly, g becomes just a simplicial map f satisfying the Dehn Property. One of the interesting features of the QSF is that, contrary to DE as such, it is a group theoretical notion too. More explicitly the following happens.

If K_1, K_2 are two finite simplicial complexes such that $\pi_1 K_1 = \pi_1 K_2 = \Gamma$ then

$$\tilde{K}_1 \in \text{QSF} \iff \tilde{K}_2 \in \text{QSF}, \tag{5}$$

hence it makes sense, in this case, to say that Γ is QSF. Nothing like (5) holds for DE. The QSF is also quite deeply connected with GSC. Quite trivially GSC implies QSF but, at least in the groups theoretical context, there is a weak kind of converse to this, see here [6].

By now the first author has proved that all finitely presented groups are QSF. An outline of the proof is to be found in [6]. The complete details are object of a trilogy, the first of which should be out in print soon [7]. The last two parts, recently completely revised and rewritten, are in the process of being typed at IHES. Reference [4] should be useful too.

The bad locus $\Sigma(\infty)$ already mentioned above is one of the main dramatis personae in the trilogy. Incidentally too, the present paper relies heavily on [6] the companion paper [14] of which shows that the bad locus $\Sigma(\infty)$ could become chaotically wild instead of being smooth. This pathology if we would not control it, would be disastrous for the trilogy.

As explained in [6], one of the difficulties in proving that all the Γ 's are QSF, is to manage to stay safely away from two “barriers” which play against each other, the so-called Stallings barrier (see [6]) and the nonmetrizability barrier, which is epitomized by our Theorem C above. What that theorem exhibits is what happens when one actually hits the nonmetrizability barrier. Although coming very close to it, the proof the all Γ 's are QSF has to stay safely away from it. In the same sense, this should be seen as the “negative” virtue of Theorem C, while its contrast to Proposition A should be seen as its “positive” virtue.

2. The main theorem

After this more general kind of an introduction, we will start making things precise. So we fix from now on an arbitrary open simply connected 3-manifold V^3 . We consider an appropriately chosen $V_h^3 \stackrel{\text{def}}{=} \{V^3 \text{ “with very many holes”}\}$ and also an almost arborescent representation

$$X = X^2 \xrightarrow{f} V_h^3 \subset V^3$$

like the (1.15) from Theorem I of the same [15]. The theorem in question provides us with a PROPER (stratified) smooth submanifold of V_h^3

$$V_h^3 \supset \Sigma_2(\infty) = r^{-1}(f(\text{LIM}M_2(f))) \xrightarrow{r} f(\text{LIM}M_2(f))$$

where $M_2(f)$ denotes the set of double points of f and r the canonical retraction $\text{Nbd} \searrow^r f X^2$.

In (2.87) from [15] this $\Sigma_2(\infty)$ was actually called $\Sigma(\infty)$, but we reserve now this later notation for (6) below.

Under the conditions above we consider the standard smooth ball B^n of dimension $n \geq 3$ and the non-compact manifold with non-empty boundary

$$V_h^3 \times B^n \supset \partial(V_h^3 \times B^n) = V_h^3 \times S^{n-1}.$$

The PROPER (stratified) smooth submanifold of codimension one (with only strata of codimension 1 and 2)

$$\Sigma(\infty) \stackrel{\text{def}}{=} \Sigma_2(\infty) \times S^{n-1} \subset V_h^3 \times S^{n-1} \tag{6}$$

will be called the **bad locus**; the reason for this terminology will become clear quite soon. Our main result is the following theorem, where for an **arbitrary** open simply-connected V^3 an appropriate version “with holes”, V_h^3 , has to be picked up.

Theorem 2.1. *For any given $n \geq 2$, there exists a sequence of smooth non-compact $(n + 3)$ -dimensional manifolds with non-empty boundaries*

$$X_0^{n+3} \xrightarrow{g_1} X_1^{n+3} \xrightarrow{g_2} X_2^{n+3} \xrightarrow{g_3} \dots$$

with the following list of properties.

- 0) The manifold X_0^{n+3} has a handlebody decomposition without handles of index one.
- 1) All the maps g_i are smooth PROPER embeddings. Moreover each g_i is either a Whitehead dilatation or the addition of handle of index $\lambda = 2$.
- 2) We also have smooth, but not necessarily PROPER embeddings $X_j^{n+3} \xrightarrow{I(j)} V_h^3 \times B^n$, giving rise to commutative diagrams

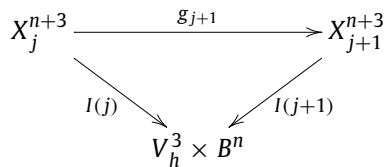

The $I(j)X_j^{n+3}$'s exhaust $V_h^3 \times B^n$. If we consider $\varinjlim X_j^{n+3} \stackrel{\text{def}}{=} \{\bigcup_j X_j^{n+3} \text{ endowed with the topology of INDUCTIVE LIMIT (= the WEAK TOPOLOGY)}\}$, then the natural map (“the identity”)

$$\boxed{\varinjlim X_j^{n+3} \xrightarrow{I(\infty) \stackrel{\text{def}}{=} \varinjlim I(j)} V_h^3 \times B^n}$$

is a CONTINUOUS BIJECTION. [Caution, $\varinjlim X_j^{n+3}$ is, generally speaking, NOT a manifold, actually not even a metrizable space.]

- 3) The space

$$W^{n+3} \stackrel{\text{def}}{=} \varinjlim X_j^{n+3} - I(\infty)^{-1}(\Sigma(\infty))$$

has a natural structure of smooth manifold with non-empty boundary, compatible with the weak topology of $\varinjlim X_j^{n+3}$. Moreover $\text{int } W^{n+3} = \bigcup_j \text{int } X_j^{n+3}$.

- 4) The map

$$W^{n+3} \xrightarrow{I(\infty)|_{W^{n+3}}} V_h^3 \times B^n - \Sigma(\infty)$$

is a diffeomorphism, while the map

$$\varinjlim X_j^{n+3} \xleftarrow{I(\infty)^{-1}} V_h^3 \times B^n$$

fails to be continuous **exactly** along the bad locus $\Sigma(\infty)$.

Complement to Theorem.

- I. There exists an infinite, locally finite, PROPERLY embedded 2-dimensional subcomplex $K_0^2 \subset X_0^{n+3}$, such that “ X_0^{n+3} is **compact in the direction transversal to** K_0^2 ”, in the sense that X_0^{n+3} is a smooth bona fide regular neighborhood of K_0 .
- II. When we restrict $I(\infty)$ to $I(\infty)^{-1}\Sigma(\infty) \subset \varinjlim(X_j^{n+3})$ endowed with its induced topology

$$I(\infty)^{-1}\Sigma(\infty) = \varinjlim(X_j^{n+3} \cap I(\infty)^{-1}\Sigma(\infty)),$$

then we get a homeomorphism

$$I(\infty)^{-1}\Sigma(\infty) \approx \Sigma(\infty) \subset V_h^3 \times B^n.$$

So we have a uniquely well-defined topological space $\Sigma(\infty)$ endowed not only with its natural embedding into $V_h^3 \times B^n$ but also with an embedding $\Sigma(\infty) \subset \varinjlim_{\beta} X_j^{n+3}$, such that the following diagram commutes

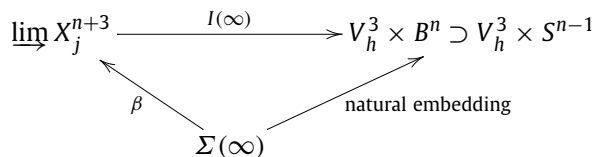

Our Theorem 2.1 above is part of the circle of ideas which are involved in the first author’s work [6] and one should also see here [3].

3. Higher-dimensional thickenings

The aim of this section is to give a number of very explicit pictures which will be useful later on. The apparent pedantry of the discussions which follows is due to the fact that, eventually, the elementary steps which we describe here will be part of an INFINITE ITERATION; and if we want this infinite iteration to converge in any reasonable sense, then some more of extra precision is required, as far as the elementary steps to be iterated are concerned. We will start by reviewing very briefly the elementary facts concerning the 4-dimensional thickening functor from [12]. In [12] we had worked with a compact 2-dimensional singular polyhedron $X \xrightarrow{f} M^3$ and/or with the **singular** compact 3-dimensional manifolds $\Theta^3(X)$ ’s obtained by thickening X 3-dimensionally, via the recipe f . But that whole story extends immediately to locally compact X ’s which are **singular locally finite generalized polyhedra**, in the sense of [15], and to their obviously defined $\Theta^3(X)$ ’s. Remember that such an $X \xrightarrow{f} M^3$ continues to be completely standard (i.e. a locally finite simplicial complex) **at the source**, and that it is only the map f which can become more exotic, leading to an $fX \subset M^3$ which is a bona fide **generalized** polyhedron (in the sense of [15]) and hence fails to be a simplicial complex, not even one which is not locally finite. But we will never talk about objects like $\Theta^3(fX)$, $\Theta^4(fX, \varphi)$ (which do not make any sense) ..., and only about the OPEN regular neighborhoods $\text{Nbd}(fX) \subset M^3$ and their product with B^n .

In [13] we have introduced desingularizations φ for X and/or for $\Theta^3(X)$ denoted by $\Theta^4(X, \varphi)$ and/or $\Theta^4(\Theta^3(X), \varphi)$, giving rise to smooth blow-ups

$$\check{\Theta}^3(X) = \check{\Theta}(X)(\varphi) \xrightarrow{\pi(\varphi)} \Theta^3(X).$$

For each φ we have a canonical 4-dimensional regular neighborhood of X and /or of $\Theta^3(X)$; moreover, there is a canonical embedding

$$\check{\Theta}^3(X) \hookrightarrow \partial\Theta^4(X, \varphi).$$

This **thickening functor** $\Theta^4(\dots)$, which is just the product by I in the case of a smooth $\Theta^3(X)$, has good gluing properties and it is invariant under acyclic $O(i)$ -moves. Finally, our 4-dimensional thickening $\Theta^4(\dots)$ also has the following two properties where the desingularization φ plays a key role.

- i) Consider an acyclic $O(i)$ -move $X \xrightarrow{p} X_1$ and a subset $E \subset X - \text{Sing } X$ which is such that $p|_X$ injects and that $pE \subset X_1 - \text{Sing } X_1$. Then we have a diagram

$$\begin{array}{ccc}
 \Theta^4(X, \varphi) & \xrightarrow{\approx} & \Theta^4(X_1, \varphi) \\
 \uparrow & & \uparrow \\
 \check{\Theta}^3(X) & & \check{\Theta}^3(X_1) \\
 & \swarrow E \searrow & \\
 & &
 \end{array} \tag{7}$$

where the upper horizontal arrow is the canonical diffeomorphism and where the other maps are the obvious inclusions.

If for every $x \in E \cap M_2(p)$ we have $\varphi(x) = N$ (and NOT $\varphi(x) = S$), then the diagram (7) COMMUTES.

- ii) To a COHERENT $O(3)$ -move $X_1 \xrightarrow{p} X_2$ there corresponds an embedding

$$\Theta^4(X_1, \varphi) \hookrightarrow \text{int } \Theta^4(X_2, \varphi)$$

such that the associated cobordism $\Theta^4(X_2, \varphi) - \text{int } \Theta^4(X_1, \varphi)$ means just addition of a handle of index two, in other words we find that

$$\Theta^4(X_2, \varphi) = \Theta^4(X_1, \varphi) + \{\text{a handle of index } \lambda = 2\}.$$

We fix now once and for all an integer $n > 4$. We have the following elementary fact

Lemma 3.1. *Let φ_1, φ_2 be two desingularizations of X . There is a canonical diffeomorphism*

$$\Theta(X, \varphi_1) \times B^{n-4} \xrightarrow[\approx]{d} \Theta(X, \varphi_2) \times B^{n-4}. \tag{8}$$

So, for each $n > 4$ there is a uniquely well-defined n -manifold

$$\Theta^n(X) \stackrel{\text{def}}{=} \Theta^4(X, \varphi) \times B^{n-4}. \tag{9}$$

Of course, this is a triviality; but it will be useful to have a very explicit description of (8). We will start by reviewing the construction of $\Theta^4(X, \varphi)$, as it is given in [11]. For $X^3 \stackrel{\text{def}}{=} \check{\Theta}^3(X)$ having as singularities the little squares $\sigma_1, \sigma_2, \dots, \sigma_r$, we have the canonical decomposition (2.6) from [11], which we rewrite here as

$$X^3 = X^3(\text{smooth}) \cup \sum_1^r K(\sigma_i)$$

where each $K(\sigma_i)$ is split from the rest of X^3 by the punctured torus $\delta K(\sigma_i)$. When we give ourselves a desingularization φ of X , each σ_i comes equipped with an embedding (leading to a Heegard splitting of S^3)

$$\check{K}(\sigma_i) = \check{K}(\sigma_i, \varphi) \subset S^3 = \partial B^4(\sigma_i); \tag{10}$$

there are exactly two embeddings (10) possible, for a given σ_i , corresponding to the possible desingularizations and each comes equipped with another embedding

$$\delta \check{K}(\sigma_i) \times [0, 1] \subset \partial B^4(\sigma_i); \tag{11}$$

here $\delta \check{K}(\sigma_i) \times 0 = \delta \check{K}(\sigma_i) \subset \partial \check{K}(\sigma_i)$ and the factor $[0, 1]$ is outgoing with respect to $\check{K}(\sigma_i)$. With this, we have

$$\Theta^4(X, \varphi) \stackrel{\text{def}}{=} (X^3(\text{smooth}) \times [0, 1]) \cup \sum_1^r B^4(\sigma_i),$$

the two pieces being glued together along $\sum_1^r \delta K(\sigma_i) \times [0, 1]$. Now, the crucial point is that (unless we are willing to reverse the parametrization of the $[0, 1]$ factor) the two possible embeddings (11) coming from the two distinct φ_{σ_i} 's are NOT ISOTOPIC.

For $n > 4$, all this gives us a unique canonical isotopy class for the embedding

$$\delta K(\sigma_i) \times [0, 1] \times B^{n-4} \subset \partial(B^4(\sigma_i) \times B^{n-4})$$

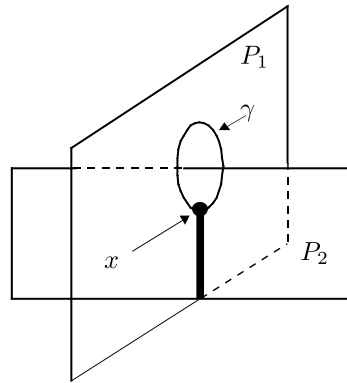

Fig. 1. We see here $\check{X}^2(\varphi) \subset \partial\Theta^4(X, \varphi)$.

which makes

$$(X^3(\text{smooth}) \times [0, 1] \times B^{n-4}) \cup \underbrace{\sum_1^r (B^4(\sigma_i) \times B^{n-4})}_{\delta K(\sigma_i) \times [0, 1] \times B^{n-4}} \tag{12}$$

independent of φ . The manifold (12) is our (9). \square

When we replace $\Theta^4(X, \varphi), \Theta^4(X_1, f)$ in (8) by $\Theta^n(X), \Theta^n(X_1)$ respectively, then we get COMMUTATIVITY, whatever φ might have been. Also every O(3)-move functions now like a COHERENT one: for any O(3)-move $X_1 \rightarrow X_2$, independently of any φ considerations, we get now an embedding

$$\Theta^n(X) \rightarrow \text{int } \Theta^n(X_1) \tag{13}$$

where

$$\Theta^n(X_1) - \text{int } \Theta^n(X) = \{n\text{-dimensional cobordism corresponding to a unique handle of index } \lambda = 2\}.$$

So **four dimensions** and the unstable COHERENCE property (the impact of which is null as soon as we move to dimensions five or more) were an indispensable ingredient for the theory from [2] and [8–11].

The rest of this section develops the elementary properties of the $\Theta^n(\dots)$ thickening functor ($n > 4$), which will be useful later on.

Let φ be a desingularization of the singular 3-manifold $X^3 = \Theta^3(X^2)$ and let $\check{X}^3 = \check{X}^3(\varphi)$ be the corresponding desingularized X^3 . We have, by definition, a projection map $\check{X}^3 \xrightarrow{\pi} X^3$ which blows up the singularities, and which is the identity on X^3 (smooth). But there is also an obvious inclusion map

$$\begin{array}{ccc} \check{X}^3(\varphi) = \check{X}^3 & \xrightarrow{i} & X^3 \\ & \swarrow \quad \searrow & \\ & X^3(\text{smooth}) & \end{array} \tag{14}$$

Except in a neighborhood of π^{-1} (singularities), where it is only well-defined up to isotopy, the map i (by definition) is rigidly equal to the identity. We will pick up, once and for all, a **base point** $\star \in \partial B^{n-4}$, which allows us to define unambiguously the embedding

$$\begin{aligned} \Theta^4(X^4, \varphi) &= \Theta^4(X^3, \varphi) \times (\star) \subset \partial\Theta^n(X^3) \\ &= (\Theta^4(X^3, \varphi) \times \partial B^{n-4}) \cup (\partial\Theta^4(X^3, \varphi) \times B^{n-4}). \end{aligned} \tag{15}$$

The induced embedding $\check{X}^3(\varphi) \subset \partial\Theta^n(X^3)$ can be extended (see (14)) to an embedding $X^3 \subset \partial\Theta^n(X^3)$.

In term of Fig. 1, the embedding $\check{X}^2(\varphi) \subset X^2$ is obtained by adding a 2-cell along the circle γ . Because of the point $x \in \gamma$ (Fig. 1) which is buried deep inside $\check{X}^2(\varphi)$, this cannot be achieved inside the 3-dimensional $\partial\Theta^4(X, \varphi)$. But as soon as an extra dimension is available there are no more problems.

At least if n is high enough, this embedding of the singular X^3 is also uniquely defined up to isotopy (irrespective of φ).

We consider next a surface $\Sigma \subset X^3$ with the following properties.

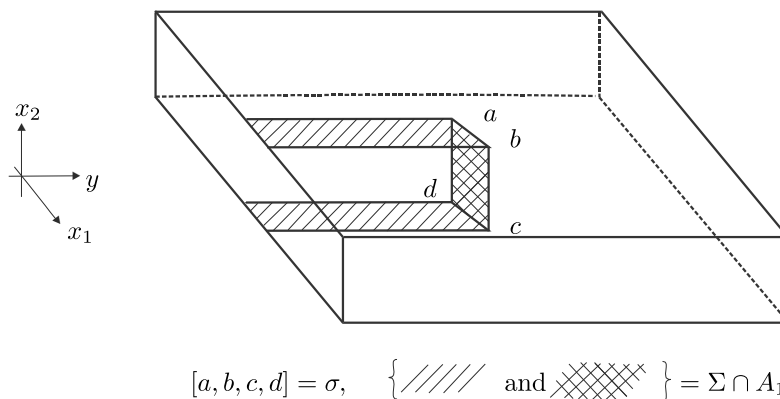

Fig. 2. A_1 and $\Sigma \cap A_1 \supset \sigma$ (doubly hatched). This σ is burred inside A_1 .

- a) If σ is singularity of X^3 , then either $\sigma \subset \Sigma$ or $\sigma \cap \Sigma = \emptyset$.
- b) If $\sigma \subset \Sigma$, then the local situation of the pair (X^3, Σ) , in the neighborhood of σ , can be described as follows. We start by considering the following two pieces of $R^3 = (y, x_1, x_2)$ which, in a first stage, will be thought of as being completely disjointed objects (see also Fig. 2)

$$A_1 = (y \in [-M, M], x_1 \in [-M, M], x_2 \in [-\varepsilon_2, \varepsilon_2]),$$

$$A_2 = \{y \in [-M, M], x_1 \in [-\varepsilon_1, \varepsilon_1], x_2 \in [-M, M]\} - \{y \in [-M, 0], x_2 \in [-\varepsilon_1, \varepsilon_1], x_1 \in (-\varepsilon_2, \varepsilon_2)\}.$$

Let also

$$\Sigma \cap A_1 \stackrel{\text{def}}{=} \{(y \in [-M, 0], x_1 \in [-\varepsilon_1, \varepsilon_1], x_2 = \pm \varepsilon_2) \cup (y = 0, x_1 \in [-\varepsilon_1, \varepsilon_1], x_2 \in [-\varepsilon_2, \varepsilon_2])\} \subset A_1.$$

The boundary of A_2 contains an obvious isomorphic copy of $\Sigma \cap A_1$ which we will call $\Sigma \cap A_2$. Let $B = A_1 + A_2$ be the two pieces being glued together along the identified $\Sigma \cap A_1 = \Sigma \cap A_2$ and let

$$\delta B = \{(y = \pm M, x_1 \in [-M, M], x_2 \in [-\varepsilon_2, \varepsilon_2]) \cup (y \in [-M, M], x_1 \in \pm M, x_2 \in [-\varepsilon_2, \varepsilon_2])\} + \{(y = \pm M, x_1 \in [-\varepsilon_1, \varepsilon_1], x_2 \in [-M, M]) \cup (y \in [-M, M], x_1 \in [-\varepsilon_1, \varepsilon_1], x_2 = \pm M)\},$$

the two pieces being glued together along the little square

$$(y = -M, x_1 \in [-\varepsilon_1, \varepsilon_1], x_2 \in [-\varepsilon_2, \varepsilon_2]).$$

This B is a neighborhood of the singularity $\sigma = (y = 0, x_1 \in [-\varepsilon_1, \varepsilon_1], x_2 \in [-\varepsilon_2, \varepsilon_2])$ in X^3 , separated from the rest of X^3 by δB .

- c) When we are far from the singularities, Σ is a proper submanifold of X^3 (with $(\Sigma, \partial \Sigma) \subset (X^3, \partial X^3)$).
- d) We have a **splitting** of X^3 along Σ into two pieces X_1^3 and X_2^3

$$X^3 = X_1^3 \cup_{\Sigma} X_2^3, \tag{16}$$

where

- d-i) in the context of b) we always have $A_1 \subset X_1^3, A_2 \subset X_2^3$ (i.e. for the singularities contained in Σ we have $\sigma \cap \text{int } X_1^3 \neq \emptyset = \sigma \cap \text{int } X_2^3$).
- d-ii) Each of the X_j^3 ($j = 1, 2$) is a singular 3-dimensional manifold and (obviously)

$$\text{Sing } X_j^3 = (\text{Sing } X^3) \cap X_j - (\text{Sing } X^3) \cap \Sigma.$$

We will call Σ a **splitting surface** for X^3 . It will be noticed that in the splitting (16) which is induced by such a Σ , the two halves do not play a symmetrical role. Let us also consider a desingularization φ for X^3 . Since $\Sigma \subset X_j^3 - \text{Sing } X_j^3$; (with $j = 1, 2$) we have embeddings $\Sigma \subset \check{X}_j^3 = \check{X}_j^3(\varphi) \subset \partial \Theta^4(X_j, \varphi|X_j)$ and $\Sigma \times [0, 1] \subset \partial \Theta^4(X_j, \varphi|X_j)$ with $\Sigma \times 0 = \Sigma$ and where the $[0, 1]$ factor is outgoing with respect to \check{X}_j^3 .

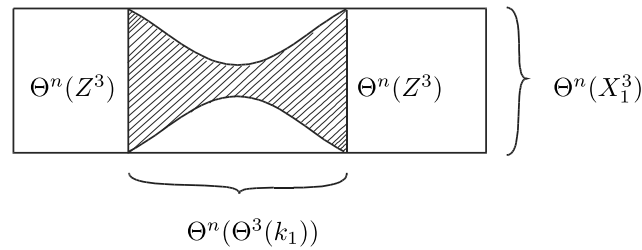

Fig. 3. Here the hatched part is $g(\Theta^n(\Theta^3(k)))$.

Lemma 3.2.

1) If for every singularity $\sigma \subset \Sigma$ we have

$$\varphi_\sigma(A_1) = N, \quad \varphi_\sigma(A_2) = S \tag{17}$$

then we have the **reconstruction formula**

$$\Theta^4(X^3, \varphi) = \Theta^4(X_1^3, \varphi|_{X_1^3}) \cup \underbrace{\Theta^4(X_2^3, \varphi|_{X_2^3})}_{\Sigma \times [0,1]}. \tag{18}$$

[One should remember here that $A_j \subset X_j^3$; if we reverse (17), even at a single σ , then the reconstruction formula (18) will, generally speaking, become false.]

2) For $n > 4$ we have the **unrestricted reconstruction formula**

$$\Theta^n(X^3) = \underbrace{\Theta^n(X_1^3) \cup \Theta^n(X_2^3)}_{\Sigma \times [0,1] \times B^{n-4}}. \tag{19}$$

Here the two halves from the right-hand side are glued via the two canonical embeddings $\Sigma \times [0, 1] \times B^{n-4} \subset \partial\Theta(X_j^3)$. [The canonical embeddings mentioned above come from

$$\Sigma \times [0, 1] \subset \partial\Theta^4(X_j^3, \varphi) = \partial\Theta^4(X_j^3, \varphi) \times (\star) \subset \partial\Theta^4(X^3, \varphi) \times B^{n-4} \subset \partial\Theta^n(X^3)$$

(see (15)) the first of these embeddings being induced by $\Sigma \subset \check{X}_j^3 \subset \partial\Theta^4(X_j^3, \varphi)$ with the $[0, 1]$ -factor outgoing with respect to \check{X}_j^3 .]

We consider now an elementary move of type O(0), O(1) or O(3) (the O(2)'s will never occur in our present context) $X \xrightarrow{G} X_1^3$, which is localized in a region $\Theta^3(k) \subset X^3$, like in the formula (2.13) from [5], formula which we rewrite here for the convenience of the reader as

$$X^3 = \underbrace{Z^3 \cup \Theta^3(k)}_{\delta\Theta^3(k)} \xrightarrow{\text{Id}(Z) \cup G} \underbrace{Z^3 \cup \Theta^3(k_1)}_{\delta\Theta^3(k_1)} = X_1^3. \tag{20}$$

Here one should remember, of course, that $\delta\Theta^3(k) = \delta\Theta^3(k_1)$.

We consider a desingularization φ accompanying (20) and if (20) is of type O(3) we assume that we are in a COHERENT situation. As it was already explained in [5] we have then an embedding

$$\begin{aligned} \Theta^4(X^3, \varphi) &= \Theta^4(Z^3, \varphi) \cup \underbrace{\Theta^4(\Theta^3(k), \varphi)}_{\delta\Theta^3(k) \times [0,1]} \\ &\xrightarrow{g} \Theta^4(Z^3, \varphi) \cup \underbrace{\Theta^4(\Theta^3(k_1), \varphi)}_{\delta\Theta^3(k) \times [0,1]} = \Theta^4(X_1^3, \varphi) \end{aligned} \tag{21}$$

which is such that $g|_{\Theta^4(Z^3, \varphi)} = \text{id}$ and $g(\Theta^4(\Theta^3(k), \varphi)) \subset \text{int}(\text{target})$ (see Fig. 3). Hence we will also have similar embeddings, which we will denote with the same letter g , for $n \geq 5$

$$\Theta^n(X^3) \xrightarrow{g} \Theta^n(X_1^3). \tag{22}$$

THE O(0) CASE. We will start by discussing the case of a **trivial** O(0)-move, where no triple points are actually involved. Once this will be understood, the rest will just follow.

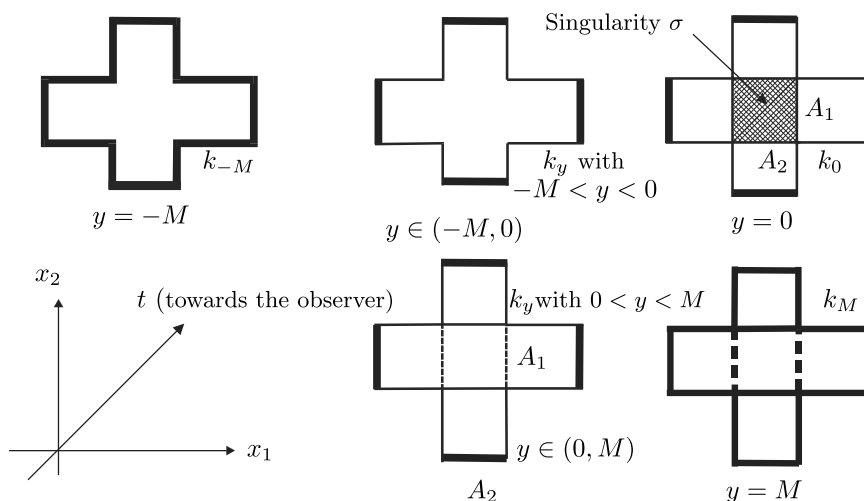

Fig. 4. A movie: at the moment $y = 0$ the two rectangles are glued together along the (doubly hatched) singularity σ . For $y > 0$ we pull the A_1 ($\varphi = S$) part towards the positive t direction, which looks towards the observer. The fat lines are in $\delta\Theta^3(k)$, except that at the extreme moments $y = \pm M$ everything is in $\delta\Theta^3(k)$ (in particular both the fat contour rectangles at $y = M$).

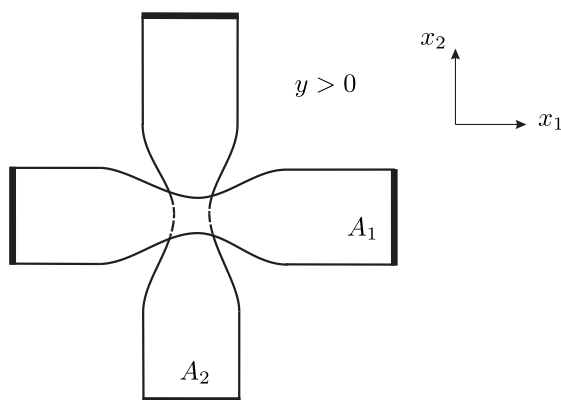

Fig. 5. The two rectangles become much slimmer along their waists.

We can as well consider that k is our

$$\underbrace{A_1 \cup A_2}_{A_1 \cap \Sigma = A_2 \cap \Sigma}$$

(see Fig. 2), where any reference to Σ is now forgotten (and hence also the asymmetry of the splitting (16); these things were only necessary in the context of the reconstruction formulae). It is understood that G performs the obvious identifications in the region $y \in [0, M/2]$, zipping away from the singularity σ , which is changed into the new k_1 -singularity

$$\sigma_1 = \{y = M/2, x_1 \in [-\varepsilon, \varepsilon], x_2 \in [-\varepsilon, \varepsilon]\}.$$

Also, once it is understood that A_1, A_2 really play now a symmetrical role, we just set conventionally $\varphi_\sigma(A_1) = S$, $\varphi_\sigma(A_2) = N$ (the other case being completely similar). We have an obvious map (which is not injective)

$$\Theta^3(k) \xrightarrow{j} R^3 = R^3 \times 0 \subset R^4(y, x_1, x_2, t).$$

Now we change the map j into an injection

$$\Theta^3(k) \xrightarrow{\mathcal{J}} R^4$$

by pulling the specified branch (A_1 in our case) towards the positive t -direction, and the corresponding regular neighborhood will be our $\Theta^4(\Theta^3(k), \varphi)$; the $[0 \leq t \leq 1]$ arc appearing in the parametrization of R^4 is the $[0, 1]$ -factor appearing in the definition of $\Theta^4(X^3, \varphi)$. Fig. 4 gives an idea of what \mathcal{J} is supposed to do.

This figure presents $\mathcal{J}\Theta^3(k) \subset R^4$ as a **movie**, with the arrow of time running in the y -direction, while the t -direction sticks out from the plane of the page, towards the observer. It will be convenient, for later pedagogical purposes, to change any of the $y > 0$ pictures into something like in Fig. 5, where the two rectangles become much slimmer along their waists. We will denote our various $\mathcal{J}\Theta^3(k)|_y$ by k_y and we will use the notation $\delta k_y = k_y \cap \delta\Theta^3(k)$. So, for all $y \leq 0$ the k_y 's

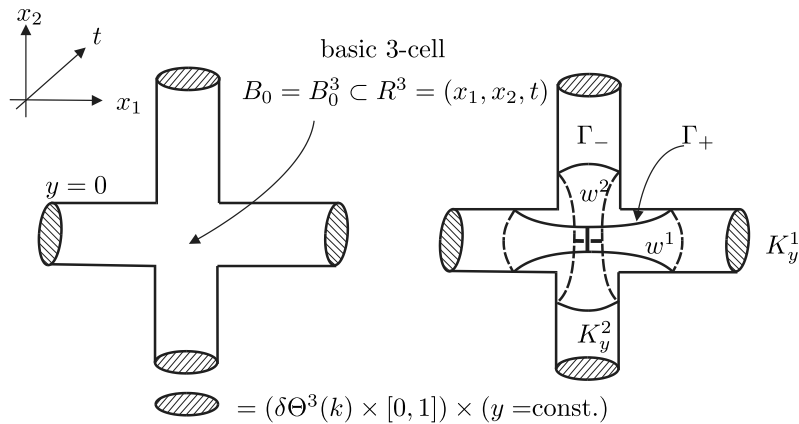

Fig. 6. In the right hand side we see $K_y = K_y^1 + K_y^2$ which is obtained by deleting the region intermediary between Δ_\pm (= the disks cobounding Γ_\pm) and then letting each K_y^ϵ become thin along the waist w^ϵ .

are connected (and isomorphic) while for $y > 0$ they are again isomorphic, but now they have two connected components instead of one. Also, the singularity σ is contained in k_0 and we have $k_{\pm M} \subset \delta\Theta^3(k)$. On the left side of Fig. 6 we see the “basic 3-cell” $B_0 = B_0^3 \subset (0, x_1, x_2, t)$, which presents itself as a thickened cross, and which is supposed to be a regular neighborhood of k_0 . For typographical convenience, the B_0^3 in Fig. 6 has been rounded up, but strictly speaking it is supposed to be exactly (i.e. metrical speaking),

$$B_0^3 = ([-M \leq x_1 \leq M, -\epsilon_2 \leq x_2 \leq \epsilon_2] \cup [-\epsilon_1 \leq x_1 \leq \epsilon_1, -M \leq x_2 \leq M]) \times [0 \leq t \leq 1], \tag{23}$$

with $k_0 = B_0^3 \cap (t = \frac{1}{2})$.

It should be stressed that $\delta k_0 \subset \partial B_0^3$. We will denote by B_y the isomorphic copy of the $B_0 = B_0^3$ (see Fig. 6 and formula (23)), obtained via translation from the moment $y = 0$ to the moment y ; we will denote this operation by T_y . When $y \leq 0$ we have $k_y = T_y k_0 \subset B_y$ but when $y > 0$, then $k_y \neq T_y k_0$. It will be nevertheless understood that $k_y \subset B_y$; the purpose of the waist-thinning from Fig. 5 was just to make this embedding possible, in the context of the “round” B_y (i.e. $\{B_0$ at the time $t = y\}$) from Fig. 6.

[In the more realistic context where (23) will be used to define B_0 and B_y , the thinning of the waist will take place **only in the vertical B^n -direction**, and no longer in the (x_1, x_2) -plane.] In our present context, the pair (D^4, D^3) from Lemma 2.0 of [5] is

$$(D^4, D^3) = \left(\bigcup_{y \in [-M, M]} B_y, \bigcup_{y \in [-M, M]} (B_y \cap (t = 0)) \right).$$

In the context of [5] we had worked under the assumption that $\partial\Theta^3(k) \cap \partial D^4 = \delta\Theta^3(k)$, but for the purpose of the present paper we work with a larger $\Theta^3(k)$, since now $\Theta^3(k) = \bigcup_y k_y$ and $k_0 \cap \partial B_0 = \partial k_0, \dots$. It will be only along the waists, IN THE VERTICAL B^n DIRECTION that things will be buried inside our present D^4 (we will come back to this later). But before this, we will describe now, in similar terms, the regular neighborhood

$$\Theta^4(k, \varphi) = \Theta^4(\Theta^3(k), \varphi) = \text{Nbd}(\mathcal{J}\Theta^3(k)) \subset R^4.$$

This time, at moment y we will find a 3-dimensional thickening K_y of k_y and the union of the K_y 's will be our $\Theta^4(\Theta^3(k), \varphi)$. For $y \leq 0$ we will have $K_y = T_y B_0$ (see (23) and Fig. 6). As already said $\partial B_0 \cap k_0 = \partial k_0 \supset \delta k_0$, and the four hatched disks which we can see on ∂B_0 are $(\delta\Theta^3(k) \times [0, 1]) \cap (y = 0)$. We denote their union by δB_0 , and completely isomorphic objects $\delta B_y \subset \partial B_y$ will appear for all $y \in (-M, M)$. For $y \in [-M, 0]$ we have $K_y = B_y$. But for $y > 0$ we get K_y from $B_y \supsetneq K_y$ via the following operations. Remembering that we are discussing for the moment the case when $\varphi(A_1) = S = \varphi(A_2)^*$ we consider to begin with, the two curves $\Gamma_\pm \subset \partial B_y - \delta B_y$ which we can see in Fig. 6. These curves bound two parallel, disjoint and properly embedding disks $\Delta_\pm \subset B_y$. We start by deleting from B_y the region intermediary between Δ_- and Δ_+ and afterwards one lets each piece become very thin along its waist. So $K_y = K_y^1 + K_y^2$ with the waist w^ϵ being a tubular neighborhood of a properly embedded disk which we call again $w^\epsilon \subset K_y^\epsilon$. The right hand side of Fig. 6 and Fig. 9 can give a complete idea of the situation. The right hand side of Fig. 6 corresponds exactly to the right hand side of Fig. 9. Anyway, isotopically speaking, what we are doing is to split $B_{y>0}$ along Δ_+ or along $\Delta_- \approx \Delta_+$ (see Fig. 8.) In the same vein, if $\varphi(A_1) = N = \varphi(A_2)^*$, then the splitting would have to be done along the two disks D_+ or D_- from Fig. 8. This K_y -movie is a complete description of $\Theta^4((\Theta^3/k), \varphi)$, up to isotopy, and one should notice that in $\partial B_y - \delta B_y$ the curve Γ_+ (respectively Λ_+), is homotopic (i.e. isotopic too) to Γ_- (respectively to Λ_-), while the curves Γ_\pm respectively Λ_\pm are **not** homotopic.

We go from $\Theta^4(\Theta^3(k), \varphi)$ to $\Theta^4(\Theta^3(k_1), \varphi)$ by replacing, for $y \in (0, \frac{M}{2}]$ each K_y by B_y .

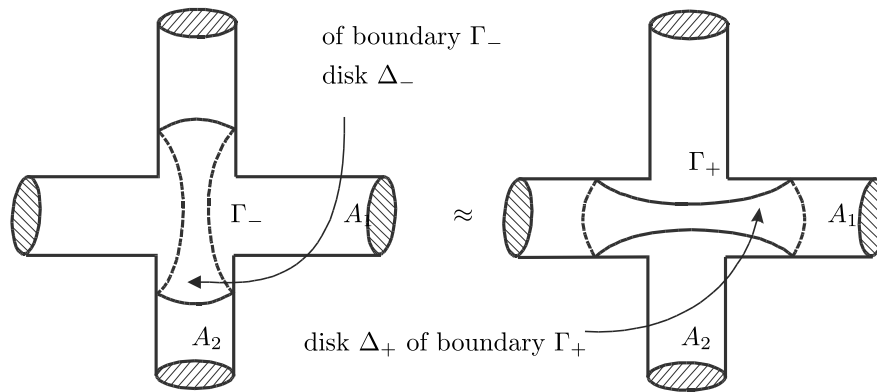

Fig. 7. Here $\varphi(A_1) = S, \varphi(A_2) = N$.

It will be understood that inside $B_{y>0}$ the two pieces of K_y are very slim along their waists. It is convenient to think of the waists as being properly embedded 2-disks. We pass from the (21) so defined to (22) simply by multiplying with a B^{n-4} factor, so that in a first approximation we have now an $(n - 1)$ -dimensional movie (with $n \geq 5$) running in the y -direction, with K_y replaced by $K_y \times B^{n-4}$. But in a slightly more precise version, for each $y > 0$ each of the $K_y^\varepsilon \times B^{n-4} \subset B_y^3 \times B^{n-4}$ has to be thinned, afterwards along its full $(n - 2)$ -dimensional waist $w^\varepsilon \times B^{n-4}$. For pedagogical reasons, we will start by describing first this process of “waist-thinning” in the not so precise context of Fig. 8, and go to the **metrically correct** (23) context only afterwards. In terms of Fig. 9, what happens can be described as follows: one starts with the $A_1 = B_y \cap (x_2 = 0)$, one rotates it along the transversal (t_1, \dots, t_{n-4}) factor and then one slims it along the waist, so that in the neighborhood of $x_1 = 0$ the new “ $K_y^1 \times B^{n-4}$ ” lives completely in the interior of $B_y^3 \times B^{n-4}$. As far as the real “ $K_y^2 \times B^{n-4}$ ” what we see for $x_2 = 0, y = y_{\text{fixed}} > 0$ is {the disk w^2 from Fig. 9} \times {a ball concentric to B^{n-4} , but of much smaller radius}. The point is that, with this, because $n - 4 > 0$ the asymmetry between the two halves of Fig. 9 has vanished.

Now $(B_y^3 \times B^{n-4} - K_y^1 \times B^{n-4}) \cap (x_2 = 0)$ is connected and $(K_y^2 \times B^{n-4}) \cap (x_2 = 0) \sim w^2 \times B^{n-4}$ is a small $(n - 2)$ -ball centered at $*(y) \in \text{int}(B_y^3 \times B^{n-4} - K_y^1 \times B^{n-4}) \cap (x_2 = 0)$. When x_2 varies from $x_2 = 0$ to $x_2 = \pm \varepsilon_2$, our $(n - 2)$ -ball continues to stay centered at $*(y)$ but increase its size. For later convenience we state the following trivial fact.

Lemma 3.3. *If $n \geq 6$, then for any fixed boundary conditions the map*

$$y \in [-\mu, \mu] \longrightarrow \underbrace{(B_y^3 \times B^{n-4} - K_y^1 \times B^{n-4}) \cap (x_2 = 0)}_{\text{this is INDEPENDENT of } y}$$

given by $y \mapsto *(y)$ is unique, up to homotopy.

This is an immediate consequence of the fact that $(B_y^3 \times B^{n-4} - K_y^1 \times B^{n-4}) \cap (x_2 = 0)$ can be retracted onto S^{n-4} , which is simply connected as soon as $n \geq 6$.

There is another way to look at the disappearance of the φ -dependence when $n \geq 5$. One can observe, to begin with, that the (K_y^1, K_y^2) pairs corresponding to Figs. 7, 8 respectively, are connected by a regular homotopy (see also Fig. 4) which crosses K_y^1 with K_y^2 . After multiplying with B^{n-4} this can be changed into an isotopy, giving us a uniquely well-defined embedding (22).

4. The operation of slackening the topology

We will begin with some abstract nonsense, and for the purpose of clarity, we will not try to avoid certain redundancies in what follows next. But, on the other hand, we will not attempt either, to expand our abstract nonsense in a more general form than the one which is really needed for our later purposes in this paper.

We will consider a smooth non-compact n -manifold Y with $\partial Y \neq \emptyset$ and an infinite exhaustion of Y by smooth, not necessarily compact n -manifolds

$$X'_0 \subset X'_1 \subset \dots \subset X'_m \subset X'_{m+1} \subset \dots \subset X'_\infty \stackrel{\text{def}}{=} Y. \tag{24}$$

We make the following assumptions.

- 1) Each of the inclusions $X'_i \subset X'_j$, where $i < j \leq \infty$, is a smooth embedding which is PROPER in the sense of general topology, i.e. the inverse image of a compact subset is compact. [We will also need to consider, later on, the case when things get improper.]
We have $Y = \bigcup_0^\infty X'_m$ and $\text{int } Y = \bigcup_0^\infty \text{int } X'_m$.

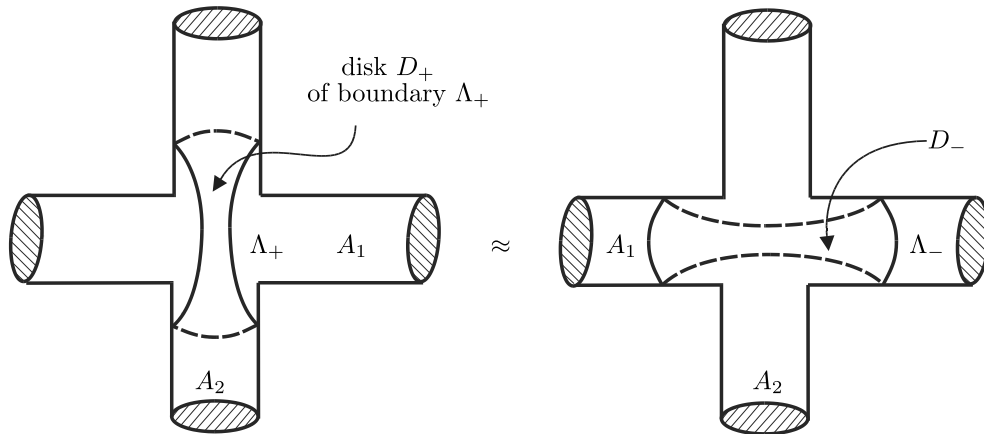

Fig. 8. Here $\varphi(A_1) = N, \varphi(A_2) = S$.

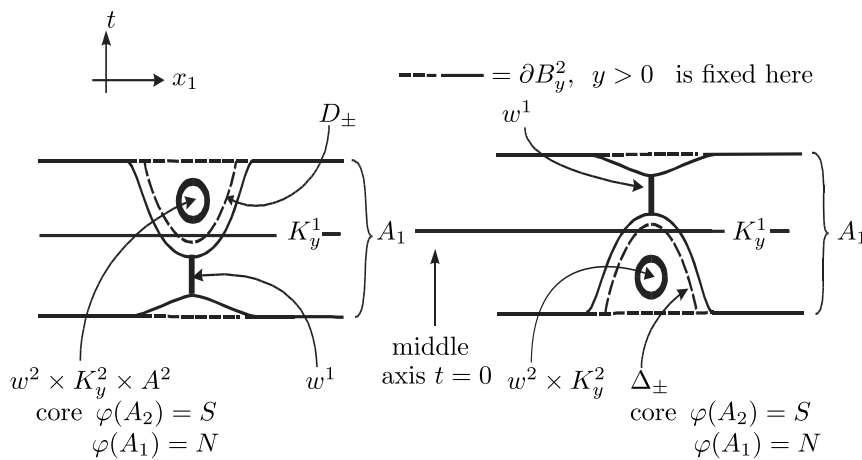

Fig. 9. We see here a section of the right hand side of Fig. 2 through the plane $x_2 = 0$. We have $A_1 \subset B_y^3$. If we make a section through $x_1 = 0$ we get completely similar figures (with the obvious $S \leftrightarrow N$ change). The waists w^1, w^2 are (essentially) 2-dimensional. The w^2 -disks are centered on the line $x_1 = 0$.

- 2) For each $m \in \mathbb{Z}^+$ there exists a codimension zero submanifold $M = M_m^{n-1} \subset \partial X'_m$ such that for the natural inclusion $X'_m \hookrightarrow X'_{m+1}$ we have $i^{-1}(\partial X'_{m+1}) = M$. Moreover $\partial X'_m$ and $\partial X'_{m+1}$ are tangent along ∂M .
- 3) For each point $p \in \partial M_m$ there is a neighborhood $p \in U_0 \subset M$ which is touched only by finitely many $(X'_\ell - X'_{\ell-1})$'s. [We do not require anything like this for points $p \in \text{int } M_m$ and this will eventually lead to what we will call **the bad locus**; (see also Fig. 10).] It is a priori clear that a point $q \in Y$ which possesses arbitrarily small neighborhoods $q \in U \subset Y$ such that U meets an infinity of distinct $(X'_\ell - X'_{\ell-1})$'s, must be of the form $q \in M_m \cap M_{m+1} \cap \dots$. What we are assuming here is that this is never the case when q is of the more special form

$$q \in \partial M_m \cap M_{m+1} \cap \dots \tag{25}$$

- 4) For a point q which is of the form (25), there is a neighborhood $q \in U_1 \subset Y$ such that if we consider the sequence

$$U_1 \cap M_m \supset U_1 \cap M_m \cap M_{m+1} \supset \dots,$$

then the following things happens:

- 3.i) Each $U_1 \cap M_m \cap M_{m+1} \cap \dots \cap M_{m+k+1}$ is a codimension zero submanifold of $U_1 \cap M_m \cap M_{m+1} \cap \dots \cap M_{m+k}$ and after finitely many steps our sequence stabilizes at some

$$U_1 \cap M_m \cap \dots \cap M_{m+\ell} = U_1 \cap M_m \cap M_{m+1} \cap \dots \cap M_{m+\ell} \cap M_{m+\ell+1} = \dots$$

- 3.ii) We also have $U_1 \cap \partial Y \cap \partial X'_m = U_1 \cap M_m \cap \dots \cap M_{m+\ell}$. For the point $q \in \partial M_m \cap M_{m+1} \cap M_{m+2} \cap \dots$ from Fig. 10, this region is suggested as a fat interval starting at q and going towards the left side of the figure.

In the concrete situations which will be of interest for us, the local situation around the q 's which verify (25) will actually be particularly simple, as we shall see later. It should be stressed that 3.i), 3.ii) are really **local statements**. In general, the sequence

$$M_m \supset M_m \cap M_{m+1} \supset \dots$$

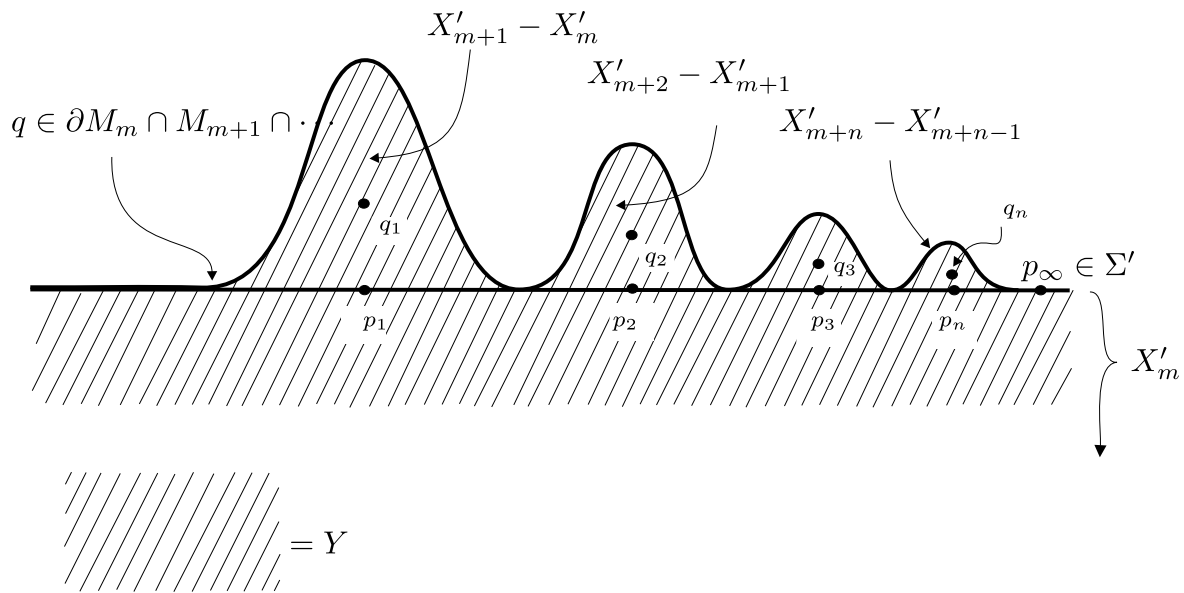

Fig. 10. We see here a piece of Y (which is hatched). In passing from the topological space Y to the topological space given from the **inductive limit** of the X'_m 's (which as a set is just Y), a sequence of the type $q_1 \in X'_{m+1} - X'_m, q_2 \in X'_{m+2} - X'_{m+1}, \dots$ like in the figure, which from the standpoint of Y converges to $p_\infty \in \Sigma'$ does not converge any longer from the viewpoint of **inductive limit** of the X'_m 's. But in the **inductive limit** of the X'_m 's as well as in Y we still find that p_1, p_2, \dots converges to p_∞ . The bumps $X'_{m+1} - X'_m, X'_{m+2} - X'_{m+1}, \dots$ from our figure become smaller and smaller from the viewpoint of Y (where they converge to p_∞) while they stay “large” (i.e. with a “size bounded from below”) from the viewpoint of the **inductive limit** of the X'_m 's; any sufficiently small neighborhood of $p_\infty \in \Sigma'$ in the **inductive limit** of the X'_m 's avoids them all. Of course, since the **inductive limit** of the X'_m 's is not metrizable, talking of sizes of its parts is only a metaphor.

does not stabilize and $\partial Y \cap \partial X'_m = \bigcap_{i=m}^\infty M_i$ is NOT a submanifold of ∂Y and/or of $\partial X'_m$ (see in particular the fat points labeled by $p_\infty \in \Sigma'$ in our Fig. 10, which serve as an accumulation point both for $\bigcap_{i=m}^\infty M_i$ and for $\partial X'_m - \bigcap_{i=m}^\infty M_i$). We define the **BAD LOCUS** $\Sigma' \subset Y$, of the exhaustion (24) as follows. A point p belongs to Σ' iff any neighborhood $p \in N \subset Y$ meets infinitely many $(X'_m - X'_{m-1})$'s. It is obvious that Σ' is a **closed** subset of ∂Y and by our assumptions $\Sigma' \cap \partial M_m = \emptyset$ for any m . The point p_∞ from Fig. 10 belongs to the bad locus.

We will consider now the **inductive limit** of the X'_m 's, denoted by $\varinjlim X'_m$ and which is endowed with the **weak topology**. This means, to begin with, that setwise $\varinjlim X'_m = \bigcup_0^\infty X'_m$, i.e. as a set $\varinjlim X'_m$ is just Y , but the topology of $\varinjlim X'_m$ is different from the topology of Y . As far as $\varinjlim X'_m$ is concerned, a set $F \subset \bigcup_0^\infty X'_m$ is closed (respectively open) iff for every $m \in \mathbb{Z}^+$ the intersection $F \cap X'_m$ is closed (respectively open). The obvious continuous bijection (i.e. the “identity map”)

$$\varinjlim X'_m \xrightarrow{I'(\infty)} Y \tag{26}$$

will be called the **slackening map** associated to the filtration (24).

[The reason for this terminology is obvious: we go from Y to $\varinjlim X'_m$ just by deciding that some sequences of points of Y which converge (in Y) are no longer convergent in $\varinjlim X'_m$.]

The space $\varinjlim X'_m$ associated to (24) is, by definition, a “**PROPER**” and **global** slackening of Y . [Here the adjective “**PROPER**” refers to the one appearing in 1) above while “**global**” refers to the fact that Y is a global manifold and not just a coordinate chart.] Fig. 10 is supposed to give an idea of the slackening operation (26). One should notice that if $\Sigma' \neq \emptyset$, which we will constantly assume to be the case, then we can find sequences $p_1, p_2, \dots, p_n, \dots$ of $\varinjlim X'_m$ converging to some $p_\infty \in \varinjlim X'_m$ but which are such that for arbitrarily chosen neighborhoods $p_i \in U_i$ we can find sequences

$$q_1 \in U_1, q_2 \in U_2, \dots, q_n \in U_n, \dots$$

which do not converge in $\varinjlim X'_m$. This also means that $\varinjlim X'_m$ is not a metrizable space and hence not a manifold either; of course the map $I'(\infty)^{-1}$ is not continuous either, but just bijective. The topology of $\varinjlim X'_m$ depends on the whole data (24) and not just on the pair (Y, Σ') . Here are a number of easy but useful properties.

- 5) The set of discontinuity points of the map $I'(\infty)^{-1}$ is exactly the bad locus $\Sigma' \subset Y$.
- 6) Let us consider the subset $I'(\infty)^{-1} \Sigma' \subset \varinjlim X'_m$ with its induced topology, i.e. $\varinjlim (I'(\infty)^{-1} \Sigma' \cap X'_m)$. The subspace $\varinjlim X'_m - I'(\infty)^{-1} \Sigma' \subset \varinjlim X'_m$ has a natural smooth n -manifold structure, compatible with its topology inherited from $\varinjlim X'_m$ and, moreover, the restriction map

$$\varinjlim X'_m - I'(\infty)^{-1} \Sigma' \xrightarrow{I'(\infty)|(\varinjlim X'_m - I'(\infty)^{-1} \Sigma')} Y - \Sigma'$$

is a diffeomorphism.

7) Assume now that the following condition is also fulfilled.

A) For any $p \in \Sigma'$ there are a neighborhood U of p in Y and an $m \in \mathbb{Z}^+$ such that $\Sigma' \cap U \subset X'_m$.
Under the assumption below, the map

$$I'(\infty)^{-1} \Sigma' = \varinjlim (I'(\infty)^{-1} \Sigma' \cap X'_m) \xrightarrow{I'(\infty)|_{I'(\infty)^{-1} \Sigma'}} \Sigma' \subset Y \tag{27}$$

is a homeomorphism onto its image. Under such conditions, we will simply write Σ' for left hand side of (27) and we will not make any distinctions between the two sides of (27). In all the cases of interest for us, the condition **A)** will always be fulfilled.

- 8) The **PROPER** global slackening operation has good gluing properties which are obvious; we leave it to the reader to make them explicit.
- 9) Two **PROPER** and global slackening

$$\varinjlim X'_p \longrightarrow Y \longleftarrow \varinjlim X''_q$$

will be called **equivalent** if the filtration $\{X'_p\}, \{X''_q\}$ are cofinal; i.e. if for every p there are an N with $X'_p \subset X''_N$ and for every q an M with $X''_q \subset X'_M$.

Examples.

- a) Assume that there is a sequence of n -manifolds X'_0, Y_1, Y_2, \dots such that our filtration takes the form $X'_m = X'_0 + \sum_i^m Y_i$ (closed decomposition). Then any permutation of the Y_i 's gives an equivalent slackening.
- b) On the other hand, if in the context of Fig. 10 we add to X'_m a small “hill” in each of the larger hills $X'_N - X'_{N-1}$ ($N > m$) so as to include in the new X'_m something like a sequence q_1, q_2, \dots (see Fig. 10) converging to p_∞ (in the new X'_m), then we get a new slackening which is not equivalent to the original one any longer; the “identity map” which connects the two slackening in question is no longer a homeomorphism.

In passing from one slackening to an equivalent one nothing changes, as far as the space $\varinjlim X'_m$, the map $I'(\infty)$ and the bad locus Σ' are concerned. In other words one gets a commutative diagram where the vertical arrows are homeomorphisms

$$\begin{array}{ccc} \Sigma' \subset \varinjlim X'_p & \xrightarrow{I'(\infty)} & Y \\ \approx \downarrow & & \downarrow \approx \\ \Sigma'' \subset \varinjlim X''_q & \xrightarrow{I''(\infty)} & Y \end{array} \tag{28}$$

We reserve the name **weak equivalence** for the existence of diagram like (28); the distinction between the two definitions of equivalence will become relevant when we will talk about **IMPROPER** slackening.

- 10) Let us define $\delta X'_\ell = \partial X'_\ell - \partial Y$. Then any neighborhood of a point $p \in \Sigma$ meets infinitely many distinct $\delta X'_\ell$, in regions where $\delta X'_\ell$ separates $X'_{\ell+1} - X'_\ell$ from X'_ℓ , and conversely.

We define now a **local PROPER** slackening of Y , as follows. We start with an open covering $Y = \bigcup U^i$ and then, for each U^i individually we give a filtration like (24)

$$X_0^i \subset X_1^i \subset \dots \subset X_m^i \subset X_{m+1}^i \subset \dots \subset X_\infty^i \stackrel{\text{def}}{=} U^i \tag{29}$$

which is a **PROPER** slackening of U^i . The filtration (29) gives rise to a slackening map for U^i

$$\varinjlim X_m^i \xrightarrow{I^i(\infty)} U^i,$$

with a bad locus which we denote by Σ^i . It is assumed that **up to equivalence** the slackening (29)|(Uⁱ ∩ U^j) and (29)|(Uⁱ ∩ U^j) (where now in (29) is $i = j$) are the same. This allows us to define the continuous bijection

$$\bigcup_i \varinjlim X_m^i \xrightarrow{I(\infty) = \bigcup_i I^i(\infty)} Y \tag{30}$$

and its bad locus $\Sigma = \bigcup \Sigma^i$. Mutatis-mutandis, the various properties of the **global PROPER slackening** remains true for the present **local PROPER slackening** (30).

We pass now to global **IMPROPER** slackening. We will never bother to consider local improper slackening, which we do not need. We start by giving ourselves a commutative diagram of smooth injective immersions between manifolds of dimension n

$$\begin{array}{c}
 X \\
 \begin{array}{l} \nearrow I(0) \\ \uparrow I(1) \\ \searrow I(m) \\ \swarrow I(m+1) \end{array} \\
 X_0 \xrightarrow{g_1} X_1 \xrightarrow{g_2} \dots \xrightarrow{g_m} X_m \xrightarrow{g_{m+1}} X_{m+1} \longrightarrow \dots
 \end{array} \tag{31}$$

where the g_i 's are PROPER, but not necessarily the $I(m)$'s. We will actually assume from now, in the context of something like (31), that all the $I(m)$'s are indeed IMPROPER. It is assumed that the subsets $I(m)X_m$ exhaust Y and also that the $I(m) \text{int } X_m$'s exhaust $\text{int } Y$. We will assume constantly that the conditions **2**), **3**), **4**) from the definition of the PROPER slackening remain true for our (31); one should notice here that the **2**), **3**), **4**) in question are just **local** conditions. In the same spirit we will define the BAD LOCUS $\Sigma \subset Y$ as the set of points $p \in Y$ possessing arbitrary small neighborhoods which meet infinitely many $(I(m)X_m - I(m-1)X_{m-1})$'s.

The obvious continuous bijection

$$\varinjlim X_m \xrightarrow{I(\infty)} Y \tag{32}$$

is, by definition, a global and IMPROPER slackening of Y attached to (31). In order to simplify the notations we will write, from now on, just $X_m \subset X_{m+1}$ in lieu of $X_m \xrightarrow{g_{m+1}} X_{m+1}$. The preceding set-up (31) is much too general for our purpose and we will only use the special case described below in this present paper. The special feature which we will eventually describe is the possibility to “reduce”, locally, the global IMPROPER slackening to a local PROPER one.

We assume now that there is a clopen decomposition for each X_m

$$X_m = X_m(1) + X_m(2) + \dots$$

which is such that:

- i) Each $I(m)|X_m(\ell)$ is PROPER, for all m 's and ℓ 's.
- ii) We have $X_m(1) \subset X_{m+1}(1)$ and for each $X_m(\ell)$ there exists an $M = M(m, \ell) > m$ which is such that

$$X_m(\ell) \subset \text{int } X_M(1) - X_{M-1}(1) \subset X_M(1).$$

Notice that the inclusion $X_m(\ell) \subset X_M(1)$ is always PROPER. It is understood here that for fixed m we have $\lim_{\ell \rightarrow \infty} M(m, \ell) = \infty$. This clearly implies that if

$$p \in \overline{I(m)X_m} - I(m)X_m \subset Y,$$

then p possesses arbitrarily small neighborhoods which meet infinitely many $(X_{\ell+1}(1) - X_\ell(1))$'s.

- iii) It is also understood that for fixed $\ell > 1$ we have

$$\lim_{m \rightarrow \infty} \{ \inf_{\lambda \geq \ell} M(m, \lambda) \} = \infty.$$

- iv) Let $\delta X_m(1) = \partial X_m(1) - \partial Y$, be like in **10**) above. For each m there is a tubular neighborhood $N(\delta X_m(1)) \subset Y$ which is such that $N(\delta X_m(1))$ is not touched by any $X_a(b)$ with $b > 1$. It follows that we have

$$\{ N(\delta X_m(1)) \cap (X_{m+1}(1) - X_m(1)) \} \cap X_m = \emptyset. \tag{33}$$

(Actually **iv**) follows from the previous conditions.) For the simplicity's sake, whenever there is no danger of confusion, we will write $X_m(1)$ in lieu of $I(m)X_m(1)$.

We will denote by φ_m the inclusion $X_m(1) \subset X_m$ and consider the obvious bijective map

$$\varinjlim X_m(1) \xrightarrow{\varphi \stackrel{\text{def}}{=} \varinjlim \varphi_m} \varinjlim X_m. \tag{34}$$

[Here is our typical example of an IMPROPER slackening.] We start with Fig. 10 which is redrawn as Fig. 11. With this, we introduce

$$\begin{aligned}
 X_m &= X'_m + \sum_1^\infty B_i, & \text{with } X_m(1) &= X'_m, \\
 X_{m+1} &= X'_{m+1} + \sum_2^\infty B_i, & \text{with } X_{m+1}(1) &= X'_{m+1}, \\
 &\vdots
 \end{aligned}$$

The point here is that, although $q_1, q_2, \dots, p_\infty$ are now all in X_m , the sequence q_1, q_2, \dots does NOT converge to p_∞ in X_m (but only in Y). This is unlike what would have happened in the counterexample **b**) from **9**) above.

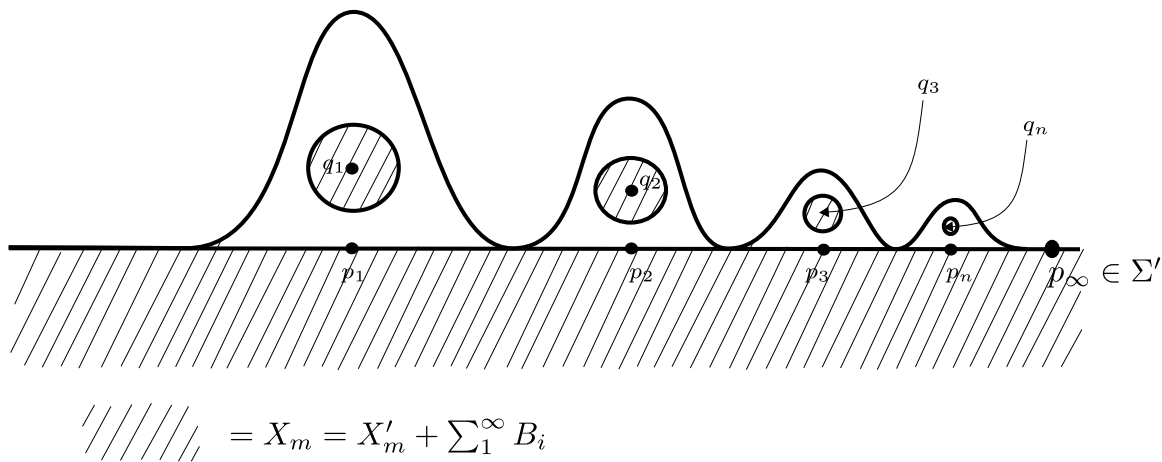

Fig. 11. Here the Y is exactly the same as in Fig. 10. For each q_i (see also Fig. 10) we consider now a “ball” B_i contained in the interior $X'_{m+1} - X'_{m+i-1}$ from Fig. 10, with center in q_i .

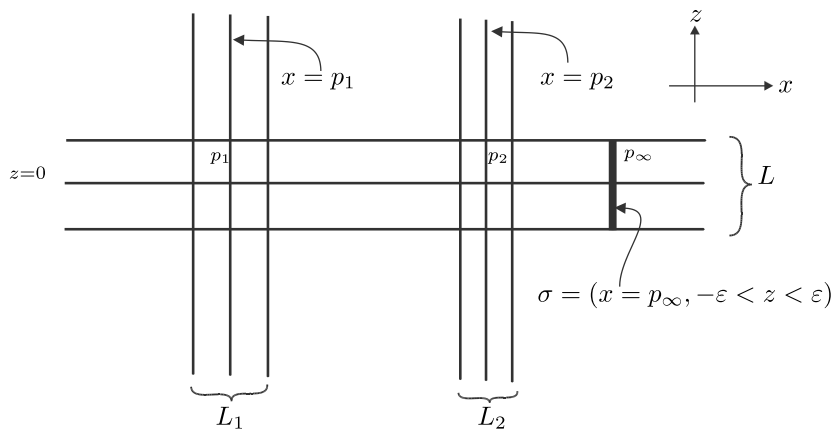

Fig. 12. The open 2-manifold. The point $x = p, z = 0$ denoted here by p .

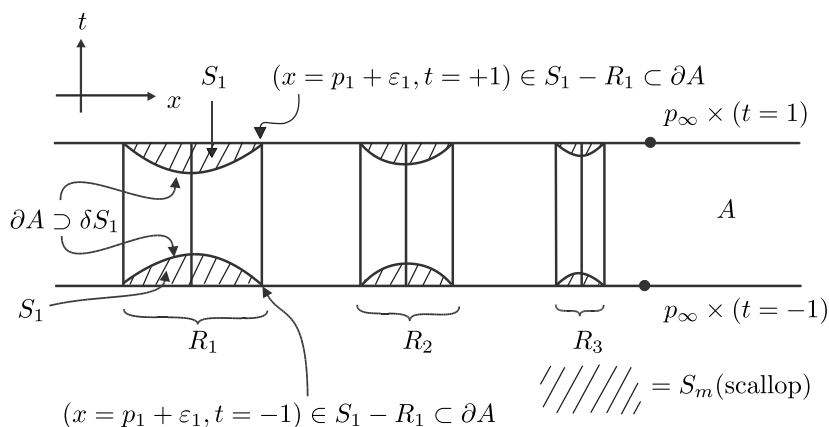

Fig. 13. $(-\infty < x < \infty) \times (-1 \leq t \leq 1) \supset A$ (white).

This makes possible the following fact: although the filtration $\{X_m\}$, $\{X'_m = X_m(1)\}$ are not cofinal, they do define nevertheless “weakly equivalent” slackening. Here is a small refinement of this construction which will be useful. Let us consider instead of just $B_i \subset X'_{m+1} - X'_{m+i-1}$ a sequence of concentric balls of increasing radii, but with a limit radius still staying very small

$$B_i \subset 2B_i \subset 3B_i \subset \dots \subset X'_{m+i} - X'_{m+i-1}.$$

With this we define, in lieu of the improper slackening from above

$$\begin{aligned} X_m &= X'_m + \sum_1^\infty B_i, \\ X_{m+1} &= X'_{m+1} + \sum_2^\infty 2B_i, \\ &\vdots \\ X_{m+\lambda} &= X'_{m+\lambda} + \sum_\lambda^\infty \lambda B_i. \end{aligned}$$

Lemma 4.1. Under the conditions above, the following things happen:

1) The filtration (which because of **ii**) above exhausts Y

$$X_0(1) \subset X_2(1) \subset \dots \subset X_m(1) \subset X_{m+1}(1) \subset \dots \subset Y$$

is a **PROPER** global slackening of Y which we denote by

$$\varinjlim X_m(1) \xrightarrow{I_1(\infty)} Y. \tag{35}$$

2) The map φ (see (34)) is a homeomorphism and the following diagram is commutative

$$\begin{array}{ccc} \varinjlim X_m(1) & & \\ \downarrow \approx \varphi & \searrow^{I_1(\infty)} & Y \\ \varinjlim X_m & \nearrow^{I(\infty)} & \end{array} \tag{36}$$

3) The bad locus $\Sigma \subset Y$ of (32) coincides with the bad locus of (35). We will say that (35) is a **PROPER global equivalent reduction** of the **IMPROPER** slackening (32) and the properties **5**), **6**) from the beginning of this section hold not only for (35), but also for (32).

4) We also make from now on the assumption that for every $p \in \Sigma$ there are a neighborhood $p \in U \subset Y$ and an $m \in \mathbb{Z}^+$ such that $\Sigma \cap U \subset X_m(1)$. Then all the arrows in the following commutative triangle are homeomorphisms

$$\begin{array}{ccc} I_1(\infty)^{-1} \Sigma = \varinjlim (I_1(\infty)^{-1} \Sigma \cap X_m(1)) & & \\ \downarrow \varphi|_{I_1(\infty)^{-1} \Sigma} & \searrow^{I_1(\infty)|_{I_1(\infty)^{-1} \Sigma}} & \Sigma \subset Y \\ I(\infty)^{-1} \Sigma = \varinjlim (I(\infty)^{-1} \Sigma \cap X_m) & \nearrow^{I(\infty)|_{I(\infty)^{-1} \Sigma}} & \end{array} \tag{37}$$

which will allow us to talk about a uniquely well-defined object Σ . It follows among other things, from everything we have said, that the slackening $\varinjlim X_m(1)$, $\varinjlim X_m$ are like in the definition of “weak equivalence” (which strictly speaking was introduced only in the context of the **PROPER** slackening).

Proof. By definition, a set $F \subset \varinjlim X_m$ is closed iff each $F \cap X_m$ is closed. But then each $F \cap X_m(1)$ is also closed, and so $\varphi^{-1}F$ is closed as a subset of $\varinjlim X_m(1)$. Conversely a set $G \subset \varinjlim X_m(1)$ is closed iff each $G \cap X_m(1)$ is closed. Hence, in view of the fact that for each $X_m(\ell)$ we have a **PROPER** inclusion $X_m(\ell) \subset X_{M(m,\ell)}(1)$, the set $G \cap X_m(\ell)$ is also closed for all (m, ℓ) 's. Since $X_m(1) + X_m(2) + \dots$ is a clopen decomposition of X_m , it follows that every $G \cap X_m$ is closed. This implies that φG is closed in $\varinjlim X_m$, and all these things prove point **2**) from our lemma.

We will denote now by $\Sigma \subset Y$ the bad locus of (32) and by $\Sigma_1 \subset Y$ the bad locus of (35). If $p \in \Sigma$ then any neighborhood $p \in U \subset Y$ is touched by infinitely many $(X_m - X_{m-1})$'s. But clearly $U = U \cap (X_0(1) + \sum_1^\infty (X_{i+1}(1) - X_i(1)))$ and so, if only finitely many $(X_{i+1}(1) - X_i(1))$'s touch U then $U \subset X_j(1)$ for some j , which is in contradiction with $p \in \Sigma$; so $p \in \Sigma_1$ too. Conversely assume now that $q \in \Sigma_1$ i.e. that an arbitrary neighborhood $q \in V \subset Y$ is touched by infinitely many $(X_{m+1}(1) - X_m(1))$'s and hence also by infinitely many $\delta X_m(1) = \partial X_m(1) - \partial Y$ in regions where $\delta X_m(1)$ effectively separates $X_{m+1}(1) - X_m(1)$ from $X_m(1)$. But then (33) tells us that V meets infinitely many $(X_{m+1} - X_m)$'s, and hence $q \in \Sigma$.

As far as **4**) is concerned, our hypothesis makes $I_1(\infty)|I_1(\infty)^{-1}\Sigma$ a homeomorphism (see condition **A**) and (27)). On the other hand, the vertical arrow in (37) is a homeomorphism since the same is true for φ in (36). Finally, since (37) is commutative, $I(\infty)|I(\infty)^{-1}\Sigma$ has to be a homeomorphism too.

Under the conditions of Lemma 4.1 (see in particular point **3**)) we can allow slightly more general reductions, in particular of the following type. We consider a **local** PROPER slackening (30) such that for each U^i the (global) PROPER slackening $\varinjlim_{m \rightarrow \infty} X_m^i$ and $\varinjlim X_m(1)|U^i$ are equivalent.

We will still call (30) a PROPER (but this time, local) equivalent reduction of (32), and the content of Lemma 4.1 remains essentially valid in this slightly more general context. \square

Definition 1. We consider an IMPROPER slackening (31), (32) of Y . We will say that the slackening is **locally reducible** if there exists an open covering $Y = \bigcup U^i$ such that the following things happen:

- a) We have a local PROPER slackening (29), (30) of Y based on the covering U^i .
- b) Each $\varinjlim X_m \xrightarrow{I^i(\infty)} U^i$ (see (29), (30)) is a PROPER equivalent reduction of the restriction $(\varinjlim X_m \xrightarrow{I(\infty)} Y)|U^i$.

Under the conditions of the definition above, we can extend Lemma 4.1 as follows

Lemma 4.2. *The obvious map*

$$\bigcup_i \varinjlim X_m^i \xrightarrow{\psi} \varinjlim X_m$$

is a homeomorphism and the following diagram is commutative

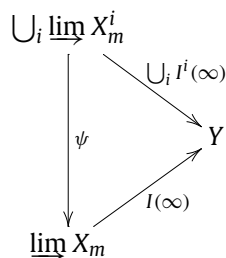

The bad locus Σ of the improper slackening coincides with the bad locus of its PROPER local reduction.

So, apart from the filtration (31) itself, the improper slackening (as far as the change of topology of Y is concerned, a.s.o.) is undistinguishable from its proper local reduction.

References

[1] S. Brick, M. Mihalik, The QSF property for groups and spaces, *Math. Z.* 220 (1995) 207–217.
 [2] D. Gabai, Valentin Poénaru's program for the Poincaré conjecture, in: S.T. Yau (Ed.), *Geometry, Topology and Physics for Raoul Bott*, International Press, 1994, pp. 139–169.
 [3] D.E. Otera, On the proper homotopy invariance of the Tucker property, *Acta Math. Sin.* 23 (3) (March 2007).
 [4] D.E. Otera, V. Poénaru, Easy representations and the QSF property for groups, *Bull. Belg. Math. Soc. Simon Stevin* 19 (2012) 1–14.
 [5] V. Poénaru, Almost convex groups, Lipschitz combing and π_1^∞ for universal covering spaces of closed 3-manifolds, *J. Differential Geom.* 35 (1992) 103–130.
 [6] V. Poénaru, Discrete symmetry with compact fundamental domain and geometric simple connectivity, preprint, Univ. Paris-Sud, Orsay, 2007-16, 2007, arXiv:0711.3579 [org/als].
 [7] V. Poénaru, Equivariant, locally finite inverse representations with uniformly bounded zipping length for arbitrary finitely presented groups, *Geom. Dedicata* (2013), in press, arXiv:0907.1738.
 [8] V. Poénaru, Killing handles of index one stably and π_1^∞ , *Duke Math. J.* 63 (2) (1991) 431–449.
 [9] V. Poénaru, Geometry “à la Gromov” for the fundamental group of a closed 3-manifold M^3 and the simple connectivity at infinity of \tilde{M}^3 , *Topology* 33 (1) (1994) 181–196.
 [10] V. Poénaru, Infinite process and the 3-dimensional Poincaré conjecture, I: The collapsible pseudo-spine representation theorem, *Topology* 31 (3) (1992) 625–656.
 [11] V. Poénaru, Infinite process and the 3-dimensional Poincaré conjecture, II: The Honeycomb representation theorem and its attached dynamical structure (second, revised version), *Prépub. d'Orsay* 93-14, 1993.
 [12] V. Poénaru, Infinite process and the 3-dimensional Poincaré conjecture, III: The algorithm, *Prépub. d'Orsay* 92-10, 1992.
 [13] V. Poénaru, Processus infinis et conjecture de Poincaré en dimension trois, IV: Le théorème de non-sauvagerie lisse (The smooth tameness theorem), *Partie A, Prépub. d'Orsay* 92-83, *Partie B, Prépub. d'Orsay* 95-33, 1995.
 [14] V. Poénaru, C. Tanasi, Representations of the Whitehead manifold Wh^3 and Julia sets, *Ann. Toulouse* 4 (3) (1995) 655–694.
 [15] V. Poénaru, C. Tanasi, Equivariant, almost-arborescent representations of open simply-connected 3-manifolds; A finiteness result, *Mem. Amer. Math. Soc.* 169 (800) (May 2004).
 [16] J. Stallings, Brick's quasi-simple filtrations for groups and 3-manifolds, in: *Geometric Group Theory*, vol. 1, in: London Math. Soc. Lecture Note Ser., vol. 181, 1993, pp. 188–203.