

DESIGN AND DEVELOPEMENT OF AN AUTOMATED PAINT MIXING MACHINE

A Thesis Submitted to

National Institute of Technology, Rourkela

In Partial fulfillment of the requirement for the degree of
Bachelor of Technology,
In

INDUSTRIAL DESIGN

By

**TAPAS RAJ
ASHIRVAD JENA**

Under the guidance of
Prof. MOHAMMAD RAJIK KHAN



**Department of INDUSTRIAL DESIGN
National Institute of Technology
Rourkela -769 008 (India)**



**National Institute of Technology
Rourkela**

CERTIFICATE

This is to certify that the thesis entitled “**DESIGN AND DEVELOPEMENT OF AN AUTOMATED PAINT MIXING MACHINE**” submitted to the National Institute of Technology, Rourkela by **TAPAS RAJ**, Roll No. **110ID0273** and **ASHIRVAD JENA**, Roll no. **110ID0262** for the award of the Degree of **Bachelor of Technology** in **INDUSTRIAL DESIGN** is a record of bona fide research work carried out by him under my supervision and guidance. The results presented in this thesis has not been, to the best of my knowledge, submitted to any other University or Institute for the award of any degree or diploma. The thesis, in my opinion, has reached the standards fulfilling the requirement for the award of the degree of **Bachelor of technology** in accordance with regulations of the Institute.

Supervisor

Dr. Mohammad Rajik Khan

ACKNOWLEDGEMENT

We take this opportunity to express our profound gratitude and deep regards to our guide Dr. Mohammad Rajik Khan, Assistant Professor, Department of Industrial Design, for his exemplary guidance, monitoring and constant encouragement throughout the course of this project. His invaluable guidance, immense help, hearted cooperation and fruitful discussions throughout the semester are embodied in this dissertation. We also express our sincere gratitude to Prof. Bibhuti Bhusan Biswal, Head of Department, Department of Industrial Design, for his keen interest and unfailing inspiration throughout the course of the project.

We are obliged to the faculty members of the Industrial Design Department of National Institute of Technology, Rourkela, for the valuable information provided by them in their respective fields and acknowledge them for their cooperation during the period of our assignment. We are extremely grateful to all lab maintenance staff for providing us assistance in various hardware and software problems encountered during the course of our project. Finally, we thank all those who are involved, directly or indirectly, throughout the course of the project.

Ashirvad Jena

Tapas Raj

ABSTRACT

Detection of desired colour and its automated generation can be very useful. Each colour has specific wavelength in visible spectrum ranging from 400nm-700nm. Based on its wavelength and other properties a machine could be developed that could utilize the principle of robotics to automatically mix the primary colors viz. red, blue and green (RGB) in required proportions to obtain the similar color as required. The automated system can be further developed to spray-paint a given area with the help of robotic arm. This fully automated system will definitely have the following benefits.

Improved quality: with an automated robotic spray painting arm, we can expect to create a more reliable, high quality end product. The robotic spray gun always remains at the proper distance away from target object hence provide accessibility in hard to reach areas with ease.

Conserve paint: it can cut down the material cost as it is precise and does not overspray.

Play-it-safe: avoid exposure to harmful toxins.

Save energy: Robotic spray allow for more compact and precise painting which requires less physical effort.

CONTENTS

1. INTRODUCTION	1
1.1 Background	2
1.2 Motivation	4
1.3 Problem definition	4
1.4 Literature review	5
1.5 Methodology	6
1.6 Layout of the thesis	7
2. DESIGN OF THE PAINT MIXING MACHINE	8
2.1 Introduction	8
2.2 Concept design	8
2.3 Detailed design	10
2.3.1 Color sensor	10
2.3.2 Controller	12
2.3.3 Interfacing	12
2.3.4 Mechanisms	14
3. FABRICATION	17
3.1 Introduction	17
3.2 Development of the prototype	17
4. CONCLUSION AND FUTURE WORKS	21
4.1 Conclusion	21
4.2 Future works	21
REFERENCES	22
APPENDIX A	

LIST OF FIGURES

Figure no.	Title	Page No
1.	Concepts for movement of color holders	8
2.	Concepts for movement of the sub-assembly	9
3.	Suction system	9
4.	Interfacing with a single stepper	13
5.	Block diagram of the setup	13
6.	The color compartments	14
7.	The base	14
8.	Rack and pinion	15
9.	Spur gear	15
10.	Syringe head	15
11.	Syringe handle	15
12.	Rack holder	16
13.	Slider	16
14.	Making of the base	17
15.	Filing the holes	17
16.	Making of the U shaped holder	18
17.	Making of the base holder	19
18.	Gear profiles	20
19.	Final assembly	20

CHAPTER 1

Introduction

Colour mixing is an important process which has a wide application in several fields. There are various kinds of colour mixing that can be done. It can either be additive colour mixing or subtractive colour mixing. Additive colour blending of shades includes blending colors of light. In added substance blending of shades there are three essential colors: red, green, and blue. Without shade or, when no colors are indicating, the outcome is dark. In the event that each of the three essential colors are indicating, the outcome is white. At the point when red and green join, the effect is yellow. At the point when red and blue join, the consequence is maroon. At the point when blue and green consolidate, the outcome is cyan. Added substance blending is utilized as a part of TV and workstation screens to generate an extensive variety of shades utilizing just three essential colors. Subtractive colour mixing is carried out by specifically evacuating certain shades, case in point with optical channels. The three essential colors in subtractive blending are yellow, maroon, and cyan. In subtractive blending of color, the unlucky deficiency of shade is white and the vicinity of every one of the three essential colors is dark. In subtractive blending of colors, the auxiliary shades are the same as the essential colors from added substance blending, and the other way around. Subtractive blending is utilized to make a mixture of colors when printing on paper by consolidating a little number of ink shades, and additionally when painting. The blending of colors does not handle immaculate subtractive color blending on the grounds that some light from the subtracted shade is even now being reflected. This outcomes in a darker and desaturated shade contrasted with the color that might be accomplished with perfect channels. This chapter develops the background for the present work and discusses the need to take up this work. It presents a review of available relevant literature. Objectives of the present work along with methodology adopted to accomplish them are also discussed here.

1.1 Background

Detection of desired colour and its automated generation can be very useful. Each colour has specific wavelength in visible spectrum ranging from 400nm-700nm. Based on its wavelength and other properties a machine could be developed that could utilize the principle of robotics to automatically mix the primary colors viz. red, blue and green (RGB) in required proportions to obtain the similar color as required. The automated system can be further developed to spray-paint a given area with the help of robotic arm. This fully automated system will definitely have the following benefits. Improved quality: with an automated robotic spray painting arm, we can expect to create a more reliable, high quality end product. The robotic spray gun always remains at the proper distance away from target object hence provide accessibility in hard to reach areas with ease. Conserve paint: it can cut down the material cost as it is precise and does not overspray. Play-it-safe: avoid exposure to harmful toxins. Save energy: Robotic spray allow for more compact and precise painting which requires less physical effort. Regarding the mixers, there are various kinds of mixers that are available now a days. These can be described below.

1.1.1 Types of paint mixing machines available

Generally there are various kinds of paint mixing machines available in the market. They vary in their size, shape, technology and methodologies. Some of the common types of machines are listed below.

Laboratory mixers

These are lab grade machines which are commonly used in laboratories now a days. It depends on high shear lab mixing ideal for research and developmental works. These are used for various kinds of applications such as mixing, emulsifying and dissolving with great precision. Their capacity can vary from 1 ml to 12 liters and offer excellent reproducibility. These are used where process validation is required.

Ultramix mixers

These are designed for applications which are beyond the capabilities of conventional mixers. They also require a lower shear. These are designed for clean in place and sterilize in place options. The dynamic mixing head provides excellent in tank movement. The large volume of materials is incorporated by a large vortex. This requires low maintenance with robust control process. The design suits excellent chemical services and sanitary requirements.

Inline mixers

These mixers are highly efficient and capable of reducing the mixing time up to a great extent. These can be modified by rapidly interchangeable work heads. This helps to mix, emulsify, homogenize and disperse the colors. The features include aeration free, self-pumping, no bypass and rapid dissolving.

Flashband mixers

These disperse powders into liquids and create a near-perfect consistent homogeneous mixture. This has one of the complex applications. It is a high shear system. It incorporates a wide range of powders. This design helps to incorporate powders on a continuous and semi-continuous basis. This system can also handle a wide range of viscosities. This design is suitable for large production and also is an agglomerate free process.

Bottom entry mixers

These are a series of high shear mixers designed to fit into the bottom of the mixers and sometimes the sides also. These are used coaxially with a slow speed stirrer anchor for high viscous products. The mixer distributes the homogenized output throughout the vessel. This is an ideal option for high viscous products like cosmetics and pharmaceuticals. These can also be used on low viscosity products to wet out powders. It uses a double mechanical shaft for operation.

Dissolver mixers

It uses a powerful and unique mixer present at the bottom of the custom built vessel. The mixer impales a great amount of suction force downwards the liquid surface pulling down the buoyant fluids. These are ripped apart and dissolved throughout the mixture.

1.2 Motivation

Conventional color mixers has a wide range of industrial applications and is used where there is a requirement of variety of colours with diversified applications. However, with the advancement in technology, more and more industries are leaning towards the use of these machines such as dyeing industries, painting industries etc. Conventional color mixing and determination process is a gruesome one and also time taking. It requires a lot of effort and consumes a great amount of time. Currently there are large mixers which are used in industries and can only be used in an industrial level. Our aim here is to design and develop such a system which can be used on the individual user level. It has to be a portable one and easy to be operated on. Similarly the function has to be simplified and should be made more user specific. The handling and operation has to be such that a layman would find no difficulty in using it.

Very limited work has been done on this level and we aim to take this forward by improving the system performance and the process.

1.3 Problem definition

Generally the existing system which are used for paint mixing are mostly industrial one. These are not accurate enough for full-proof use. Hence we aim of developing a system that can be used at personal level, manipulate automatically, can be more accurate and can give the desired output. The Objective of the work can be shown below:

- Detection of color of a given object.
- Mixing of primary color pigments (RGB) in desired proportions to get the exact match of the detected color.

1.4 Literature review

In line of colour mixing technology, few works have been done related to the inkjet printer technology. The work related to an inkjet printer, an ink billing system and to control method for an inkjet printer has been approached by researchers (Koike *et al* [2007]). Research related to the formulation of color ink composition for use in ink jet printing applications was published by Causley and Petersen [1989]. Researches on color sensor for recognizing the hue of articles by sensing rays of light passed through or reflected from the articles was done by Kanazawa *et al* [1987]. Works related to the types of color sensors i.e. contact types and non-contact types were done by DiCarlo *et al* [2010].

1.4.1 Detecting the color of the sample

This product senses the color of an object placed in front of it or the color of light shining onto the sensor device. Four analog outputs are provided, which give intensity of each of the primary color as well as the overall light levels. The output gives a UART-compatible reading for each primary component as well as overall intensity. In order to provide sensing capabilities, LED illuminations have been provided by a boost mode controlled current driver system to attain full brightness with minimum supply voltage. The LED's may be dimmed by means of analogue input, which may be tied to the supply to obtain full brightness to ground to turn them off which is used to sense the color of incoming light and dimmed by means of potentiometer. The sensor samples –all three primary colors components as well as the overall light level. The output of these four parameters is presented in two ways, as a set of analogue outputs and as a UART compatible serial data stream.

1.4.2 Use of spectrophotometer

Visible light is somewhere in the middle of wavelength and this is what the spectrometer analyses to match point. In this, white light is the illumination source, in the form of tungsten bulb or LED. A clip located on the outside of machine holds the sample to be matched, & white light is flooded onto it. The light is reflected off the sample back into the machine and onto a

small wheel. The wheel is highly efficient color analyser constituting of a number of interference filters and powered by stepper motors. Each filter is programmed to allow a specific wavelength of light to pass through it and each wavelength is within particular range of nanometres.

The wavelength representing the correct color match passes through the correct filter and is then picked up with fiber optics and piped to a photo diode. The photo diode converts the information to an electronic signal, which is then send to computer software that formulates the exact amount of pigments needed to make the match.

1.4.3 Use of image sensor and Baeyer filter

The image sensor is a device that connects on optical image into an electronic signal. It is used mostly in digital cameras. The digital cameras use either a CCD image sensor or a CMOS sensor.

A CMOS imaging chip is a type of active pigment sensor and is a semiconductor. The extra circuitry next to each sensor converts the light energy into voltage. Further circuitry converts the voltage to digital data. Baeyer filter mosaic is a filter array for arranging RGB color filter on a square grid of photo sensor. It has color filter array in a mosaic placed over the pixel sensor s. they filter the light by wavelength range, such that separate filtered intensity include information about the color of light. The raw image data captured is converted to a full color image (i.e. intensities of 3 primary colors represented by each pixel) by a demosaicing algorithm which is tailored for each type of color filter.

1.5 Methodology

The various steps involved in the making of the product are as follows:

- Detection of color and deciding its RGB proportion using a colour sensor.
- Positioning and selection of colours.
- Insertion of various mechanisms for the working of model.
- Assembly of the parts used in the prototype.

1.6 The Layout of the Thesis

A brief overview of the work carried out in the thesis and organization of the same are summarized below.

Chapter 1 presents the background, motivation and problem definition of the thesis work. Here, brief information is given for the color mixing processes, color theory and a brief description of the mixers used. It is followed with a brief review of the relevant literature. This chapter concludes with the scope of the work along with the methodology adopted to accomplish the work.

Chapter 2 deals with the design aspects of the developmental process. It includes the concept design and the detailed design of the prototype.

Chapter 3 deals with the fabrication process of the prototype. It includes the methods used to make the prototype and the tools and machineries used for the process. It also includes the materials used in the process.

Chapter 4 summarizes the significant findings of the work performed and provides some recommendations for future work that would be helpful in the further development of the product and its helpfulness.

CHAPTER 2

Design of the paint mixing machine

2.1 Introduction

The design of the paint mixing machine involves the initial stages of concept design and their purposes. Different concepts of color picking mechanisms, use of sensors and microcontroller were decided and finally a specific one was chosen after evaluating them on the basis of complexity, ease of fabrication and simplicity. Then, a detailed design of the same was presented which includes individual features, specifications and CAD model presentation.

2.2 Concept design

In the concept design various mechanisms for the different systems like placing of the container below the color picker, movement of the color picker and sub-assembly were made.

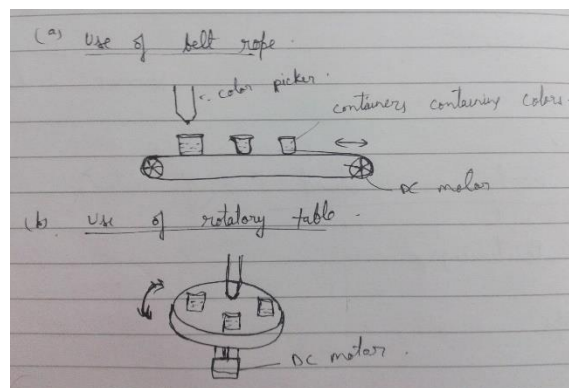

Fig 1: Concepts for movement of color holders.

Chapter 2: Design

For movement of the color holder use of belt mechanism and rotating system were made out of which rotating system was chosen due to its less complexity and simplicity in design.

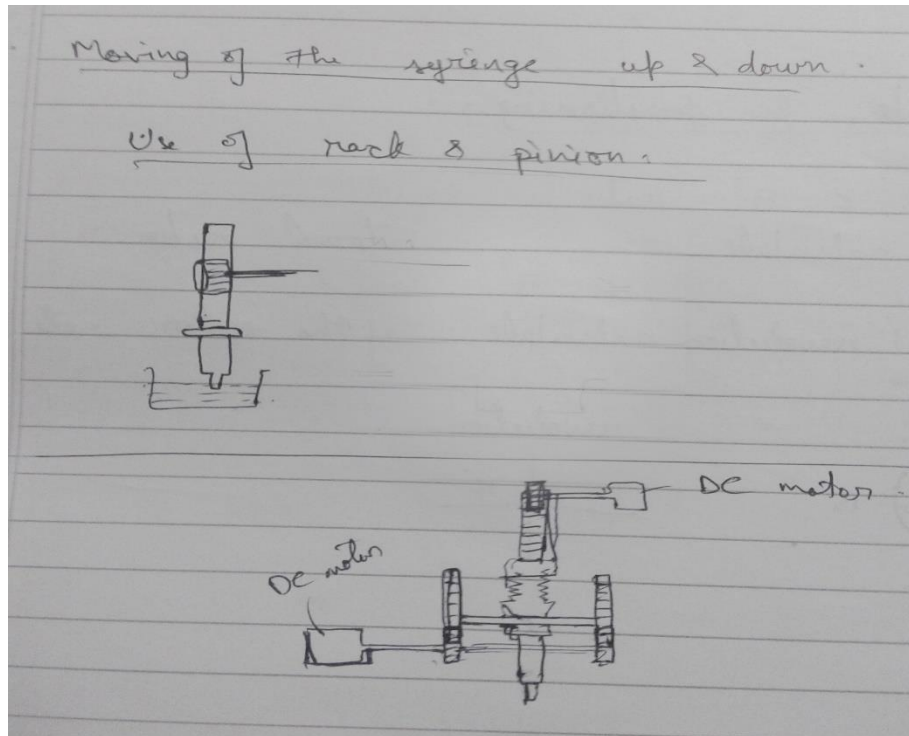

Fig 2: Concepts for movement of the sub-assembly

The movement of the upper sub-assembly was to be hold by the mesh of rack and pinion, so to make the holding strong two rack and pinion were put instead of one as shown below.

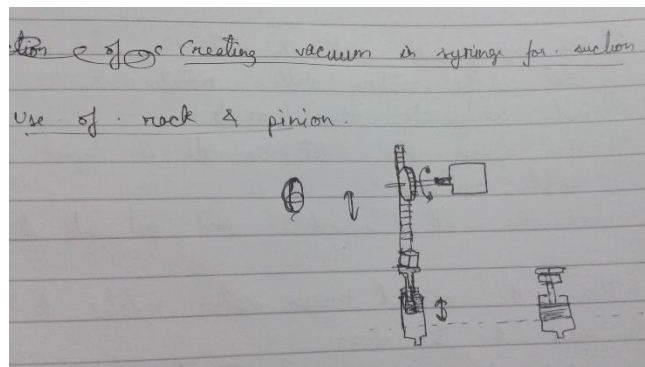

Fig 3: Suction system

2.3 Detailed design

The detailed design includes the electronics parts as well as the mechanical parts and the mechanisms that are used in the development of the prototype. As for the electronics parts, we have used the color sensor and the arduino controller. These parts along with the interfacing is can be described as below.

2.3.1 The color sensor

The Cs0105rs is an advanced color and/ or light sensor intended to precisely infer the shade chromaticity and luminance (power) of surrounding light and furnish a computerized yield with 16-bits of determination.

The module is planned around color sensor Tcs3414cs with advanced yield I2c. In light of the 8*2 show of separated photodiodes and 16-bit simple-to-advanced converters, you can measure the shade chromaticity of encompassing light or the color of articles. Of the 16 photodiodes, 4 have red channels, 4 have green channels, 4 have blue channels and 4 have no channel (clear). With the synchronization data stick, an outside beat light source can give exact synchronous change control.

FEATURES

- Easy to use 8-pin breakout
- 16-Bit Digital Output over I2C at max frequency of 400 kHz
- On-board Regulator
- Operating voltage of 4.5 V to 5.5 V ($\pm 0.2V$ max)
- Programmable Interrupt Function with User-Defined Upper and Lower Threshold Settings
- SYNC Input Synchronizes Integration Cycle to Modulated Light Sources (e.g. PWM)
- Operating Temperature Range: 0C to 60C ($\pm 10\%$)
- Programmable Analog Gain 1,000,000-to-1 Dynamic Range

Chapter 2: Design

APPLICATIONS

- Ambient light sensing
- Object color sensing
- Robotics for distinguishing/identifying colors
- Colored Line sensing
- Industrial Process Control
- Tablets, Laptops, Monitors
- HDTVs.

PIN CONFIGURATIONS:

SIDE A1		SIDE A2	
Pin	signal	pin	signal
1	GND	8	SYNC
2	Vcc	7	INT
3	SDA	6	Vcc
4	SLC	5	GND

ELECTRICAL SPECIFICATIONS:

Vcc: 4.5 to 5.0V (typical)

3.7 V (minimum)

5.5 V (maximum)

Current drawn: 16 mA

Temperature: 0 to 60 degree Celsius (ambient)

2.3.2 Controller

We have utilized the ARDUINO ADK controller for our work. The Arduino ADK is a microcontroller board focused around the Atmega2560. It has a USB host interface to join with Android based telephones, taking into account the Max3421e IC. It has 54 advanced information/yield pins (of which 15 could be utilized as PWM yields), 16 simple inputs, 4 Uarts (equipment serial ports), a 16 Mhz gem oscillator, a USB association, a force jack, an ICSP header, and a reset catch.

Power: The Arduino ADK could be fueled by means of the USB association or with an outer power supply. The force source is chosen consequently. The board can work on an outside supply of 5.5 to 16 volts. The ADK has 256 KB of glimmer memory for putting away code (of which 8 KB is utilized for the boot loader), 8 KB of SRAM and 4 KB of EEPROM. The Arduino ADK could be modified with the Arduino programming. Each of the 50 computerized sticks on the ADK could be utilized as an info or yield, utilizing pinmode(), digitalwrite(), and digitalread() capacities. They work at 5 volts. Each one pin can give or get a most extreme of 40 mama and has an inner force-up resistor (detached of course) of 20-50 Kohms.

2.3.3 Interfacing

The interfacing includes connecting all the individual parts together to form the functional unit. Here we need to connect the colour sensor to the micro controller and the robotic arm to the controller. The robotic arm generally consists of several joints and the end effector. The joints can be controlled by the means of stepper motors. So we have used several bipolar stepper motors for this purpose which are connected to the controller. The microcontroller takes the digital input while the stepper motor takes the analogue input. So it is necessary to use a motor drive through which we can control several motors at a time. Connection of a single stepper motor to the controller can be shown as follows:

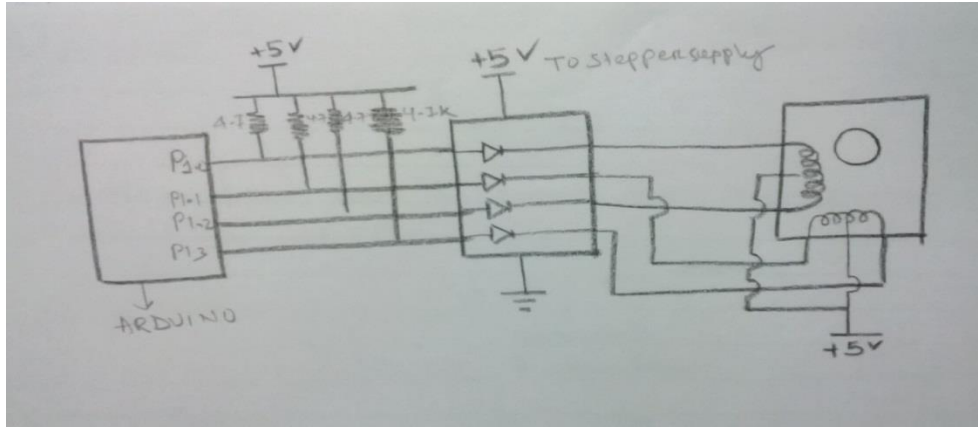

Fig 4: Interfacing with a single stepper

The whole system can be shown in the form of block diagrams as follows:

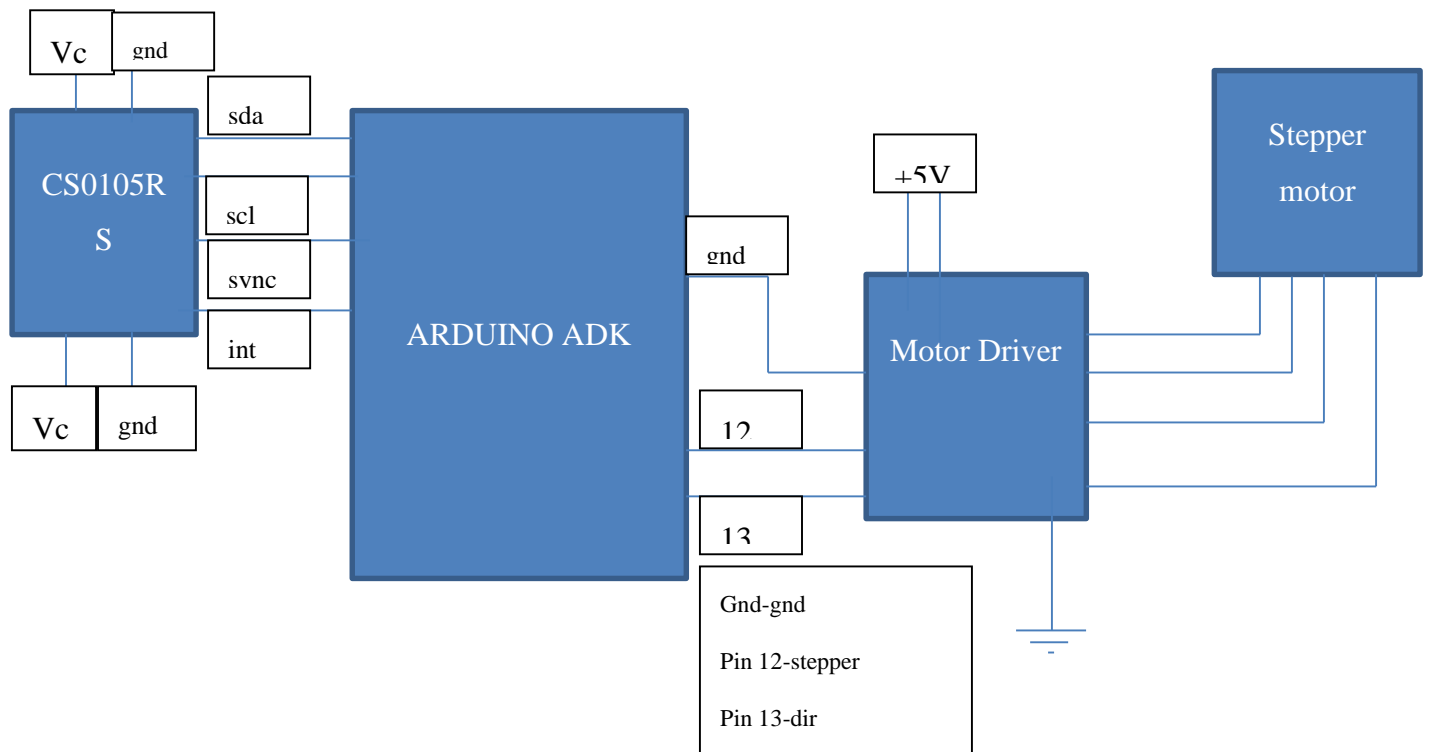

Fig 5: Block diagram of the setup

2.3.4 Mechanisms

The mechanisms involved in the equipment are for the following functions:

Suction and pouring of colors

This mechanism is used to select the appropriate amount of color into the syringe and pouring it into the mixing vessel. This uses a rack and pinion arrangement of gears attached to it at the end of the syringe. The accuracy of the derived color depends on the number of steps or gear present. More the number of teeth more is the accuracy.

Lifting and dipping of colors

This is used to lift up or down the syringe in the appropriate colored container. This also uses a rack and pinion arrangement. This does not depend upon the number of teeth present in the gear.

Mixing of colors

This is used to select the color and mixing time by agitating. This uses a high torque motor for fast agitation and precise rotation.

Parts used

A number of parts have been used to derive the given mechanisms and the setup. These are as follows:

- 1) **The base:** It consists of a flattened structure on which the primary color compartments are kept. This is rotated by using a high torque motor. It can be rotated for selecting the color and for shaking the fourth compartment for mixing of the color. It is shown as follows.

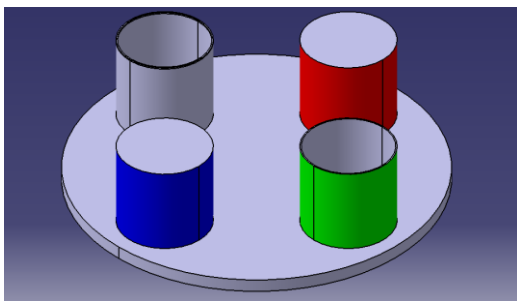

Fig 6. The color compartments

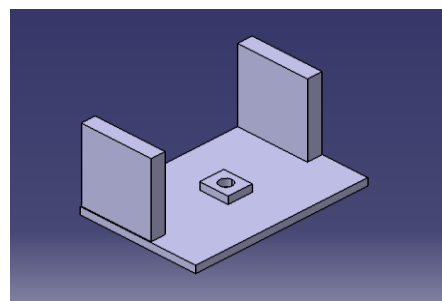

Fig 7. The base

- 2) **Rack and pinion:** This gear type is used to combine linear and rotary motion. Here these gears are mainly used to control the linear motions that are used for various purposes such as lifting and dipping of the syringe and sucking in and out of the colors.

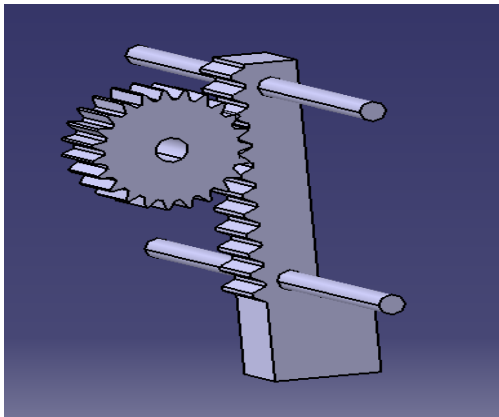

Fig 8. Rack and pinion

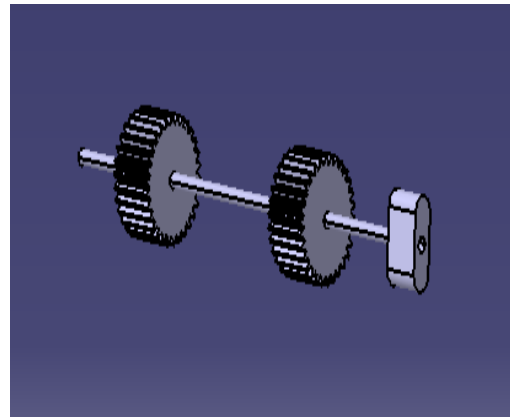

Fig 9. Spur gear

- 3) **Syringe:** A plastic syringe is used to create the suction for the color to take it from the container. It requires a larger load on the operator to work on the syringe so a high torque motor is attached to the tail of this syringe which can be pushed or pulled out.

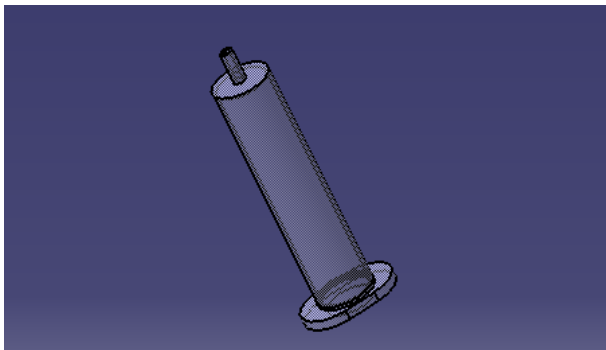

Fig 10. Syringe head

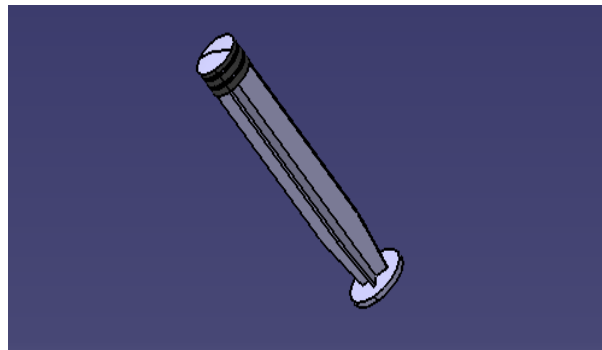

Fig 11. Syringe handle

- 4) **Rack holder and slider:** This is a frame to hold the slider for the rack and pinion. It supports the rack when the torque is applied to it. The small structure at the base supports the syringe when force is applied to its base.

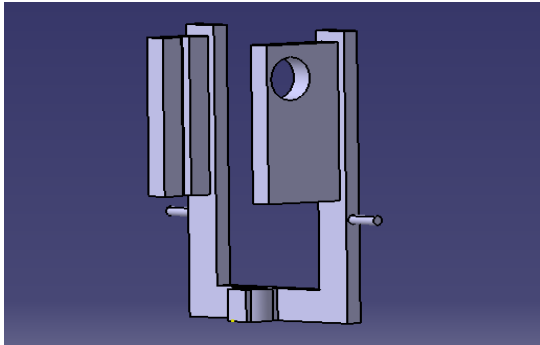

Fig 12. Rack holder

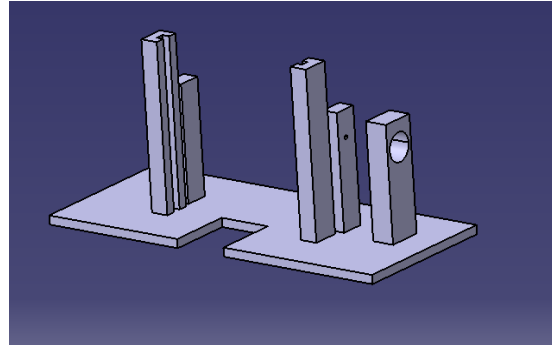

Fig 13. Slider

CHAPTER 3

Fabrication

3.1 Introduction

Fabrication involves giving a physical form to the prepared model. Fabrication was mostly done using the wooden parts. Some parts which were difficult to make using wooden structures, were made using the FDM machine. The base and the support structures were made using the wooden parts and the rack and pinion gears were made in the FDM machine. The fabrication of each part and mechanism are described in the following section.

3.2 Development of the Prototype

Rotating holder

It was made using plywood. Two circular plywood of 300 mm diameter was cut using engraving machine and was filed to give the shape. On one of the plate 4 circular holes were made of 70mm diameter aligned at 90° to each other, for holding the color containers. Then, both the plates were sandwiched together.

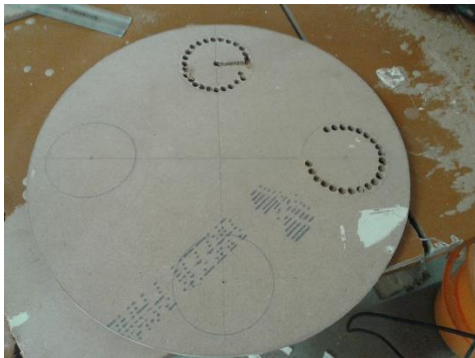

Fig 14: Making of the base



Fig 15: Filing the holes

Middle Rack Holder

A U-shaped block was cut to mount rack and color picker. On separate blocks slots were made using chain drilling followed by finishing for holding and keeping the racks in vertical position. Then, all the parts were assembled as shown in the figure.

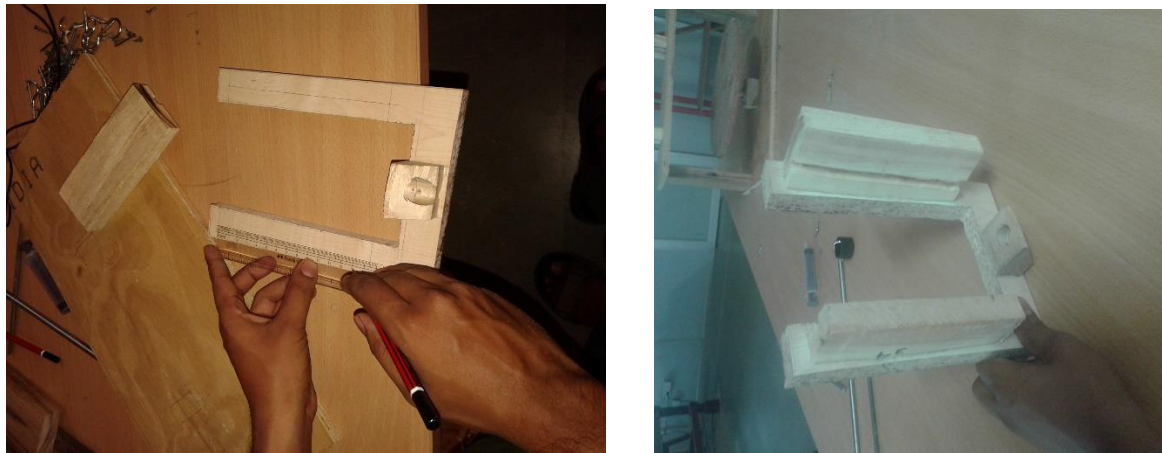

Fig 16: Making of the U shaped holder.

Rotating base support

A block of wood was taken and a slot was made using a vertical drill and then the engraving machine. A ball bearing was placed in the slot and the wooden base for color holder was suspended using a small piece of vertical stick so that it could rotate freely on applying a slight force. The assembly is shown as below.

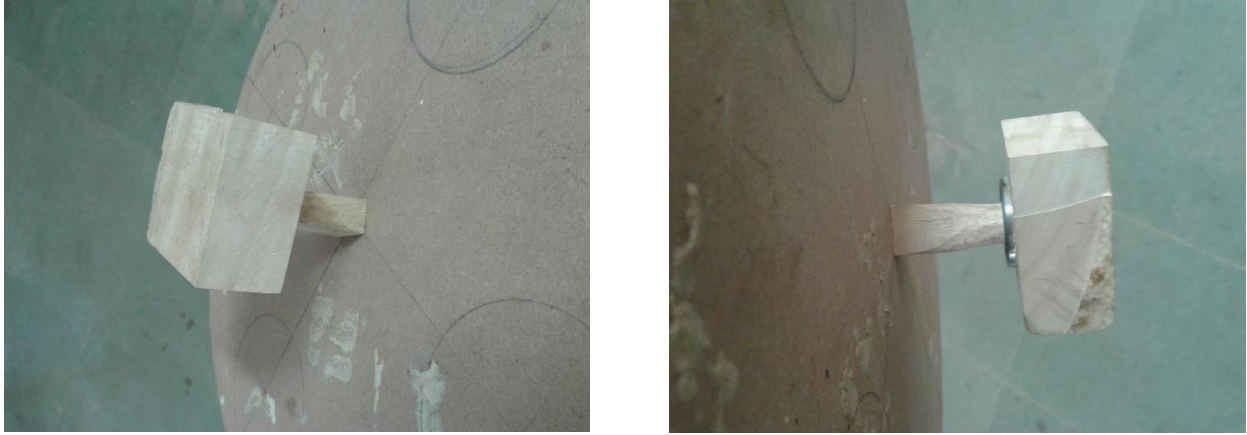

Fig 17: Making of the base holder.

Middle rack and pinion

The rack and pinions are made by using the FDM machine. First the 3d CAD model was developed and then modelled. The gear parameters are given below.

GEAR FORMULAE

The following gear parameters were used.

1. Z : number of teeth
2. D : reference diameter
3. M : gear module
4. R_o : pitch radius
5. R_t : addendum circle radius
6. R_d : dedendum circle radii
7. M_r : module of the rack

Now,

$$M = D/Z$$

$$R_t = R_o * 0.99 * M$$

$$R_t = R_o + 1.24M$$

$$R_d = R_o - 1.24M$$

For the design of the rack, the module of the spur and the rack teeth are matched

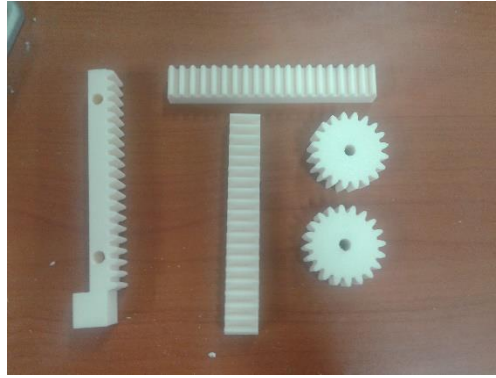

Fig 18: gear profiles

Color picker

The color picker picks up the required color and drops it in the mixing vessel. We have used a vacuum syringe as the picker. When the handle of the syringe is pulled upwards it picks up the color and when pushed, it releases the color. This is attached with the top holder with the help of a solid hollow block. The arrangements and the gears are shown as below.

The assembly

The final assembly is shown below.

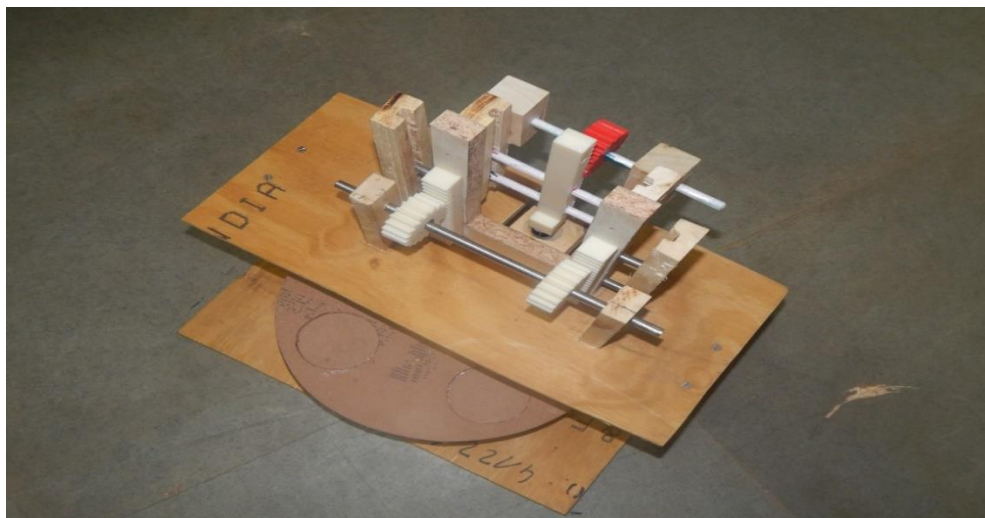

Fig 19: Final assembly

CHAPTER 4

Conclusion and Future works

4.1 Conclusion

By this setup we can determine the exact RGB proportions of any sample color except black as it is derived by subtractive color mixing. The mechanical model of the product was completed and all the mechanisms were checked for working.

4.2 Future works

The product can be fully automated by using a microcontroller and servo motors.

The product can be further have applications on robotic arms and industrial setups.

References

Bhachech *et al*, non-contact and contact type color sensor devices, US 8422016 B2, 2013

Koike T, Motoyama H & Murahash K, Inkjet printer, ink billing system, and inkjet printer control method, 2013

Murray R, printer ink cartridge with drive logic integrated circuit, US 5646660 A, 1997

Petersen M & Causley G, ink jet printer ink composition and process for producing same, US4818285 A, 1989

Websites

[1] Capturing Color, <http://www.howstuffworks.com/cameras-photography/digital/digital-camera4.htm>, 2014

[2] Cs0105rs sensor, www.robosoftsystems.co.in/roboshop/media/catalog/CS0105RS.htm, 2012

[3] Paint mixers, <http://www.silverson.com/us/paints-and-pigments.html>, 2010

Appendix

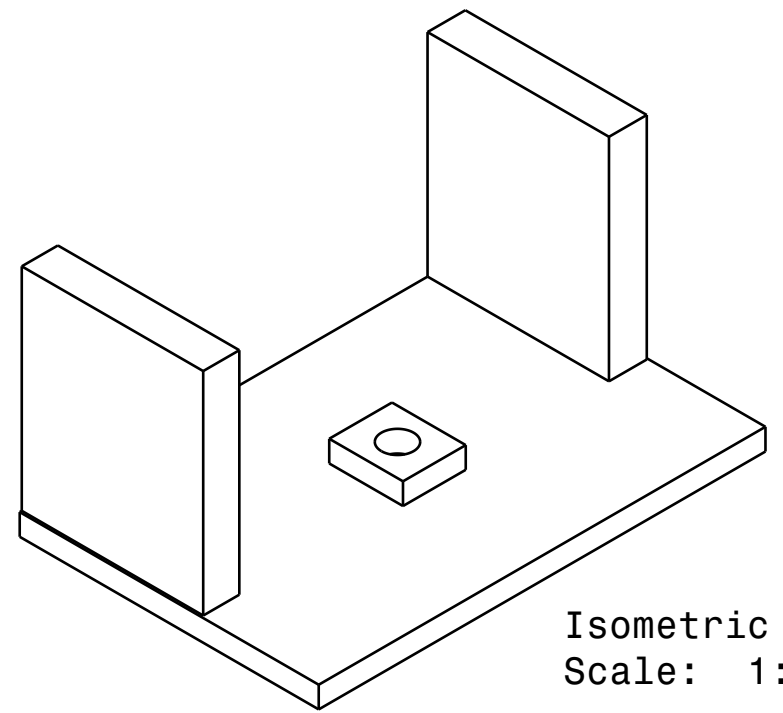
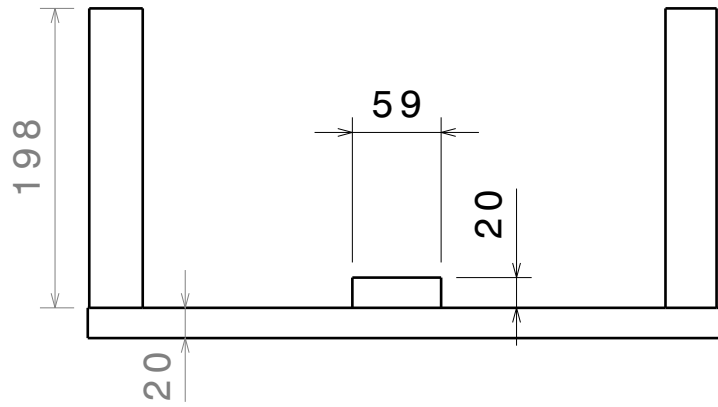

Isometric view
Scale: 1:5

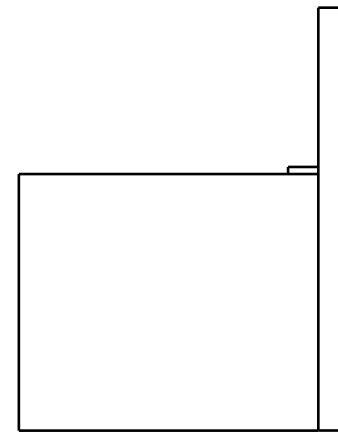
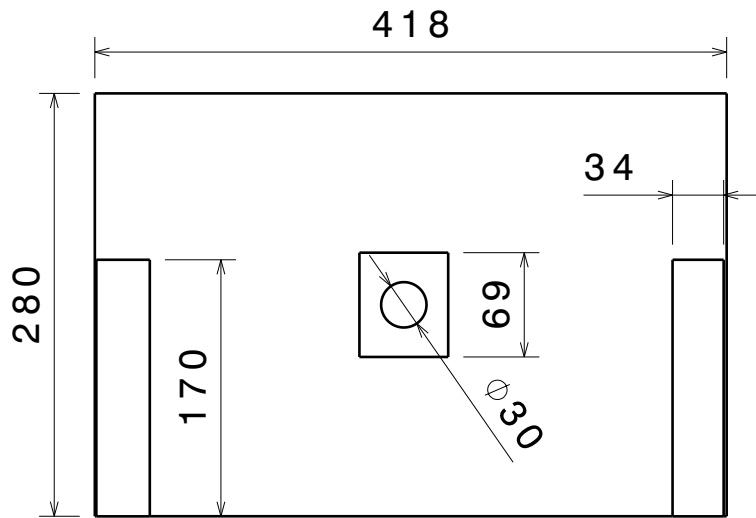

Base

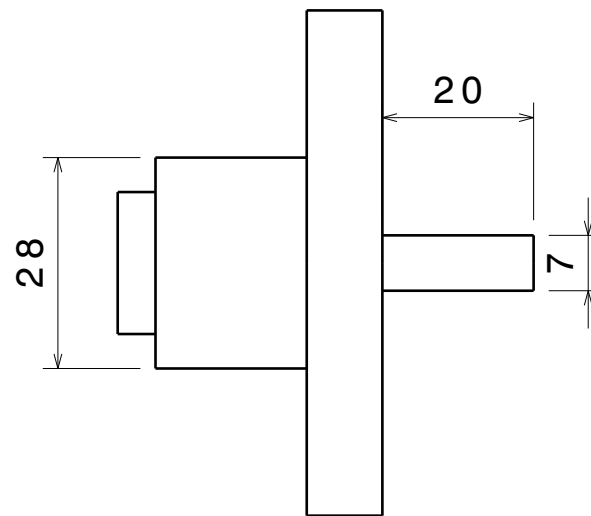
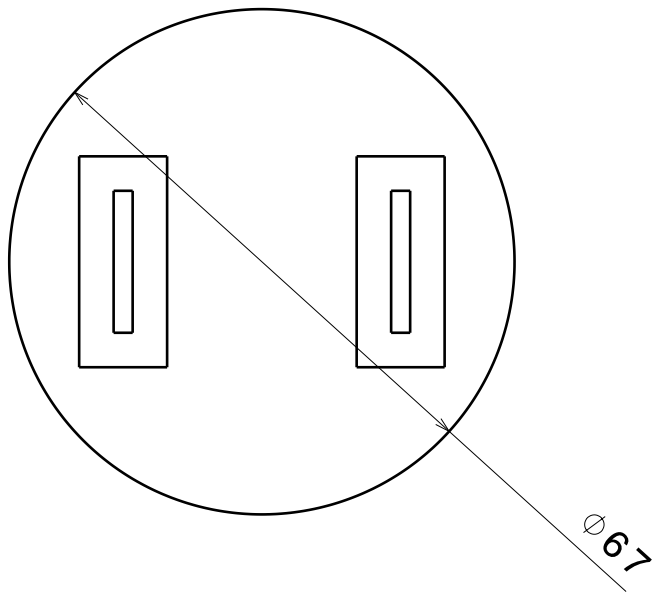
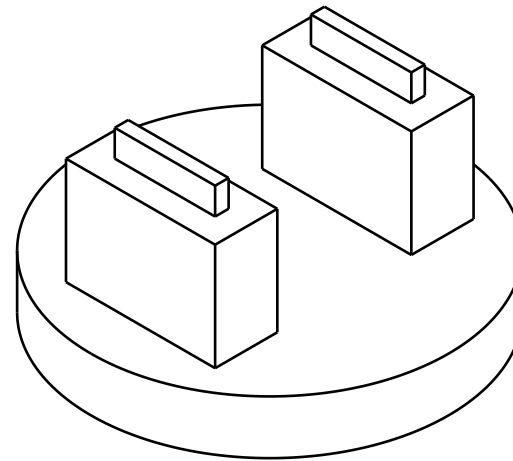
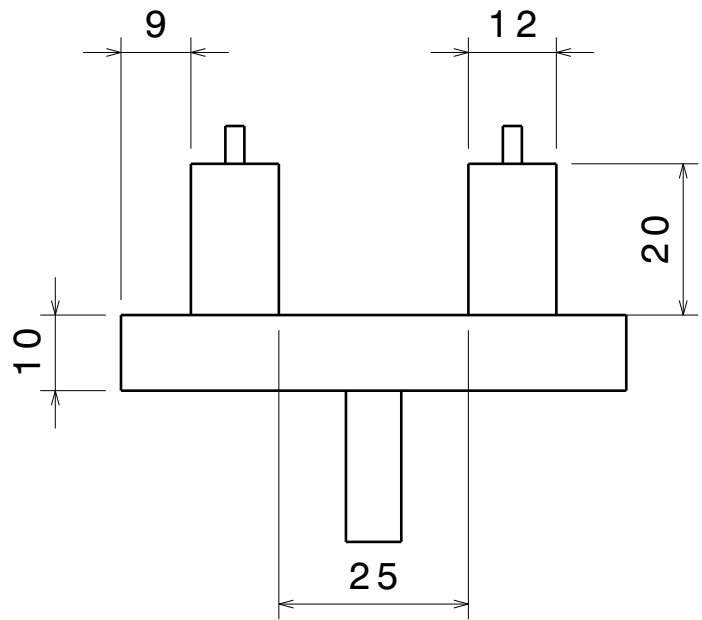

Base Support

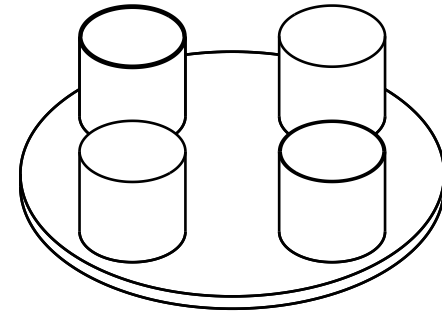
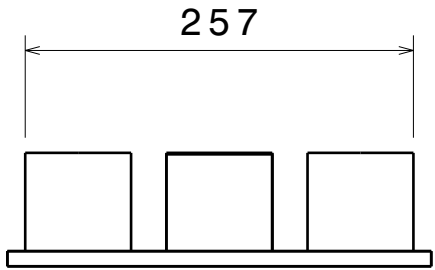

Isometric view
Scale: 1:5

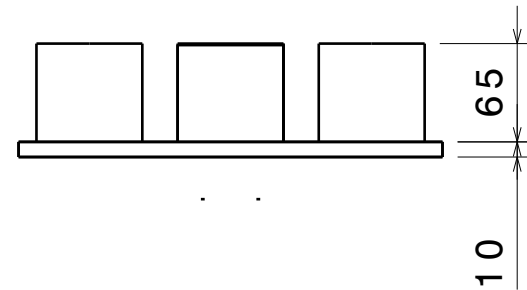
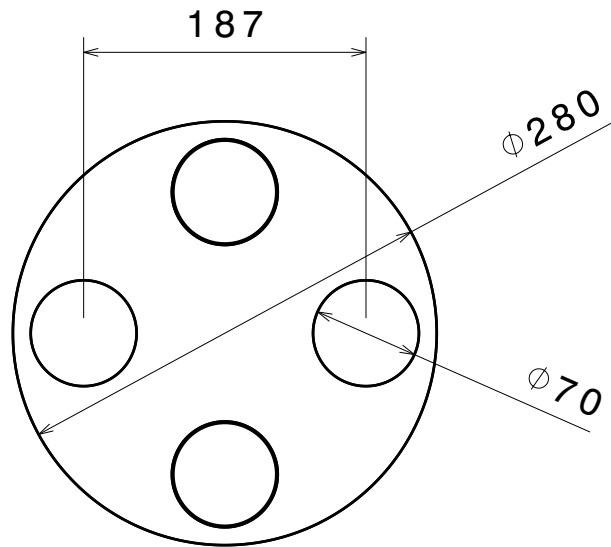

Rotating Holder

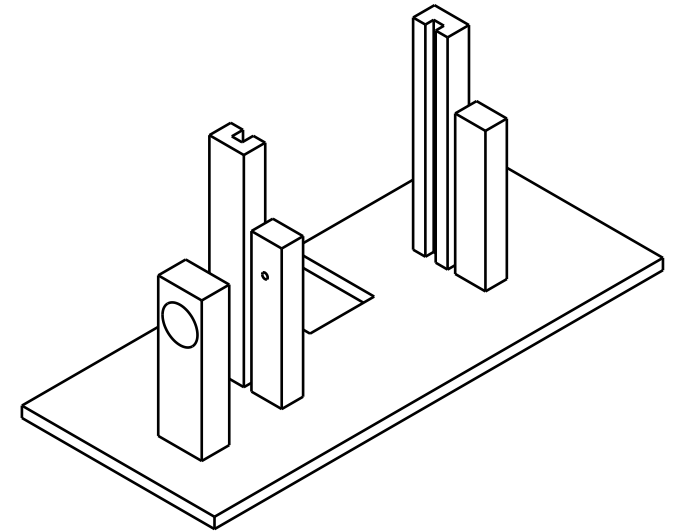
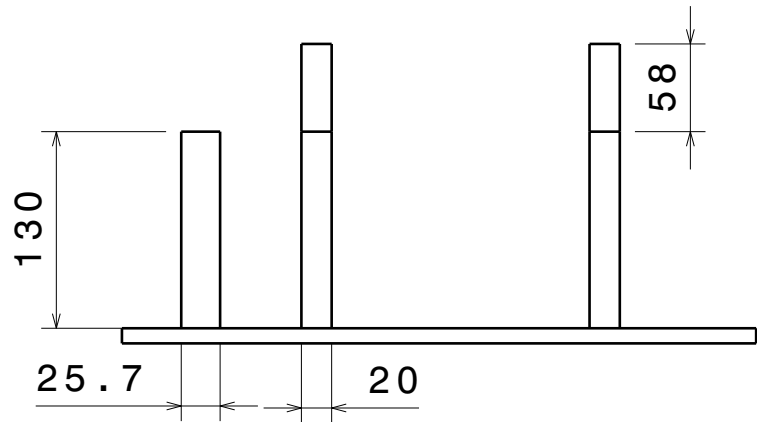

Isometric view
Scale: 1:5

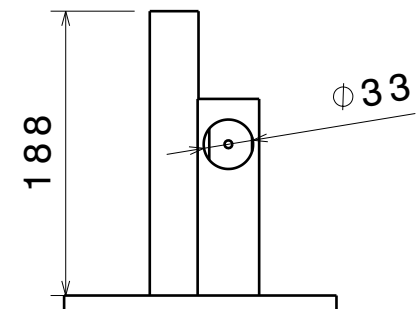
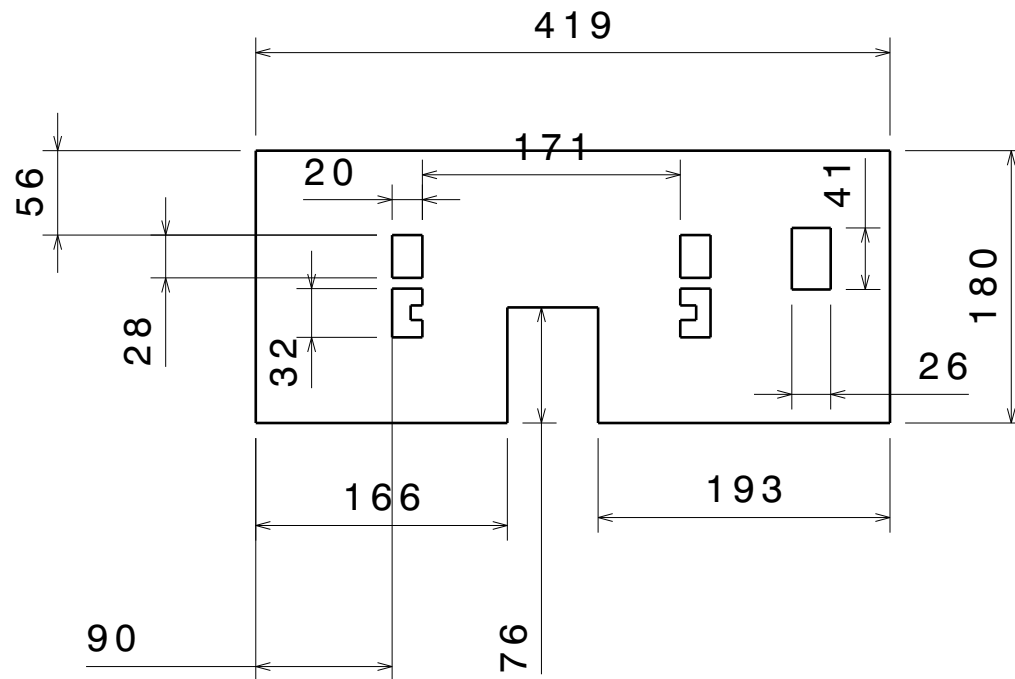

Top Base

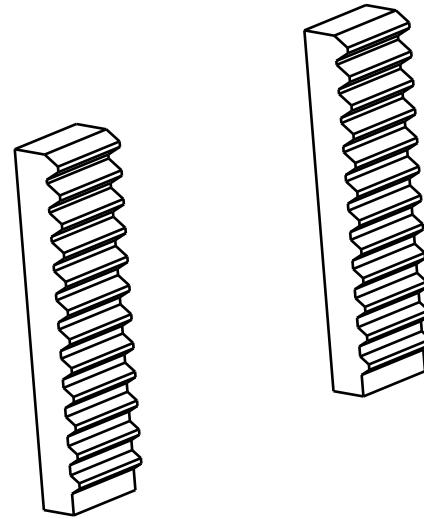
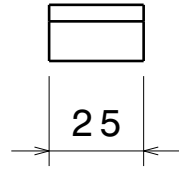
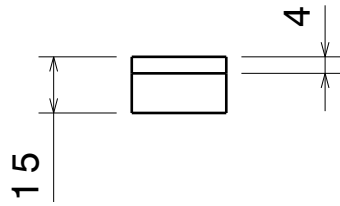

Isometric view
Scale: 1:2

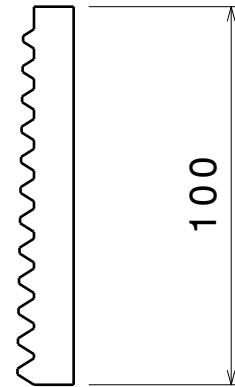
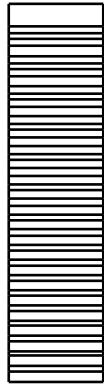
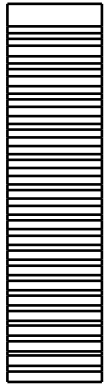

Middle Rack

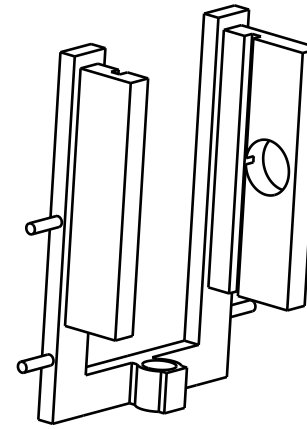
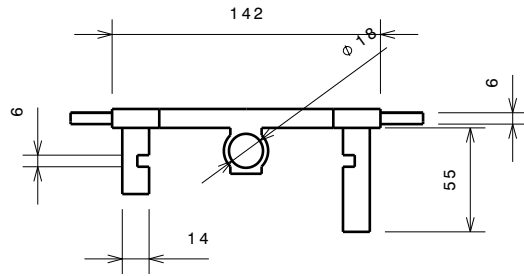

Isometric view
Scale: 1:4

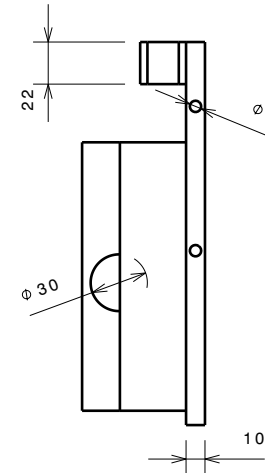
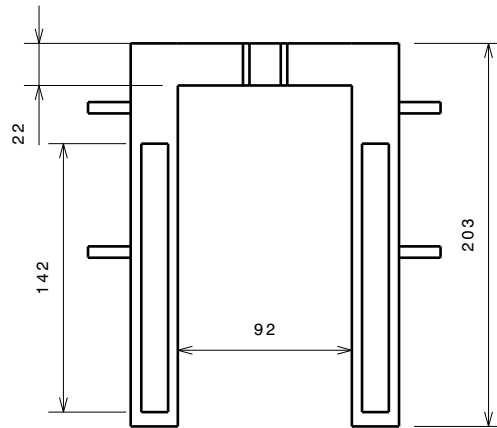

Middle Rack Holder

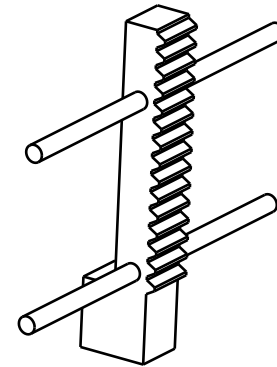
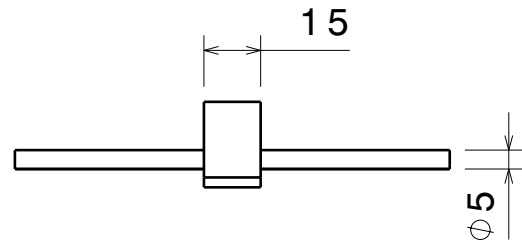

Isometric view
Scale: 1:2

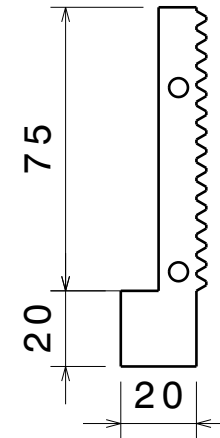
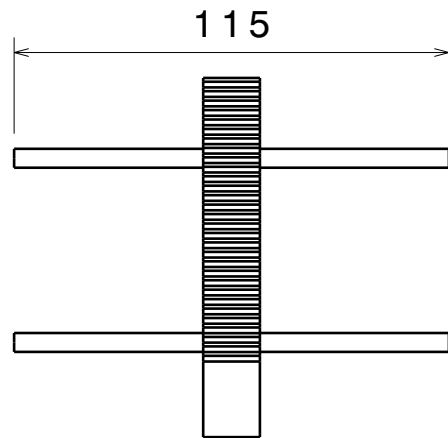

Top Rack

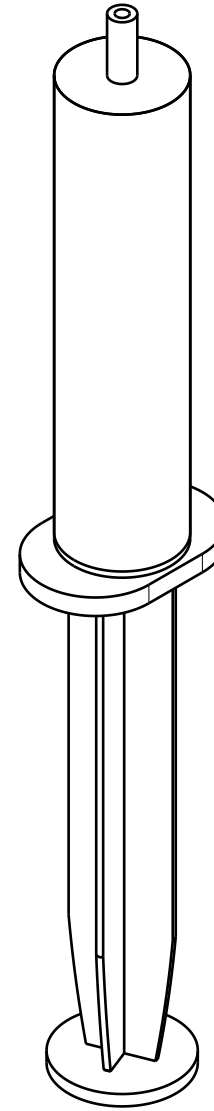
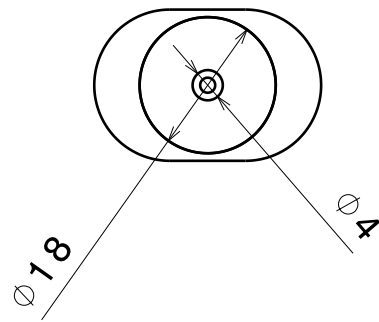
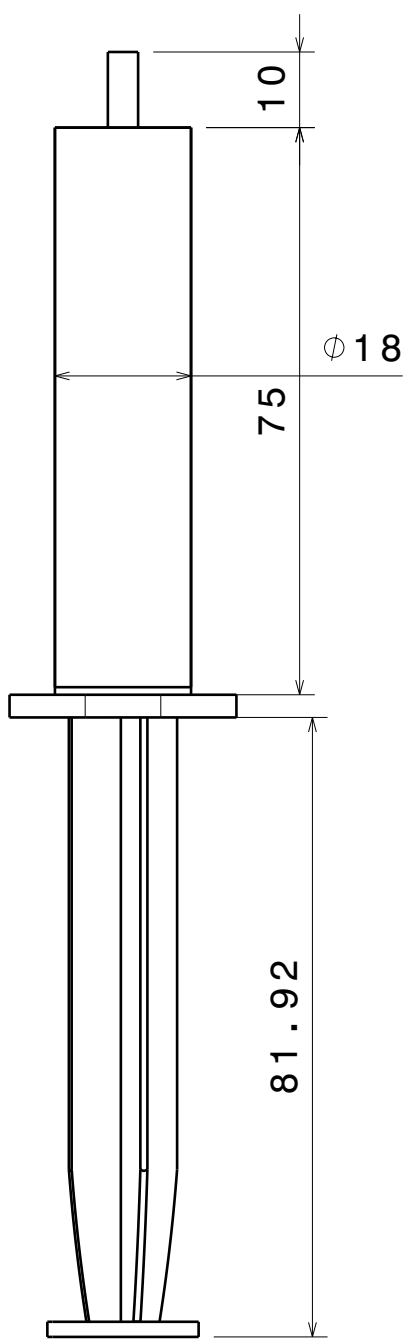

Isometric view
Scale: 1:1

Color Picker

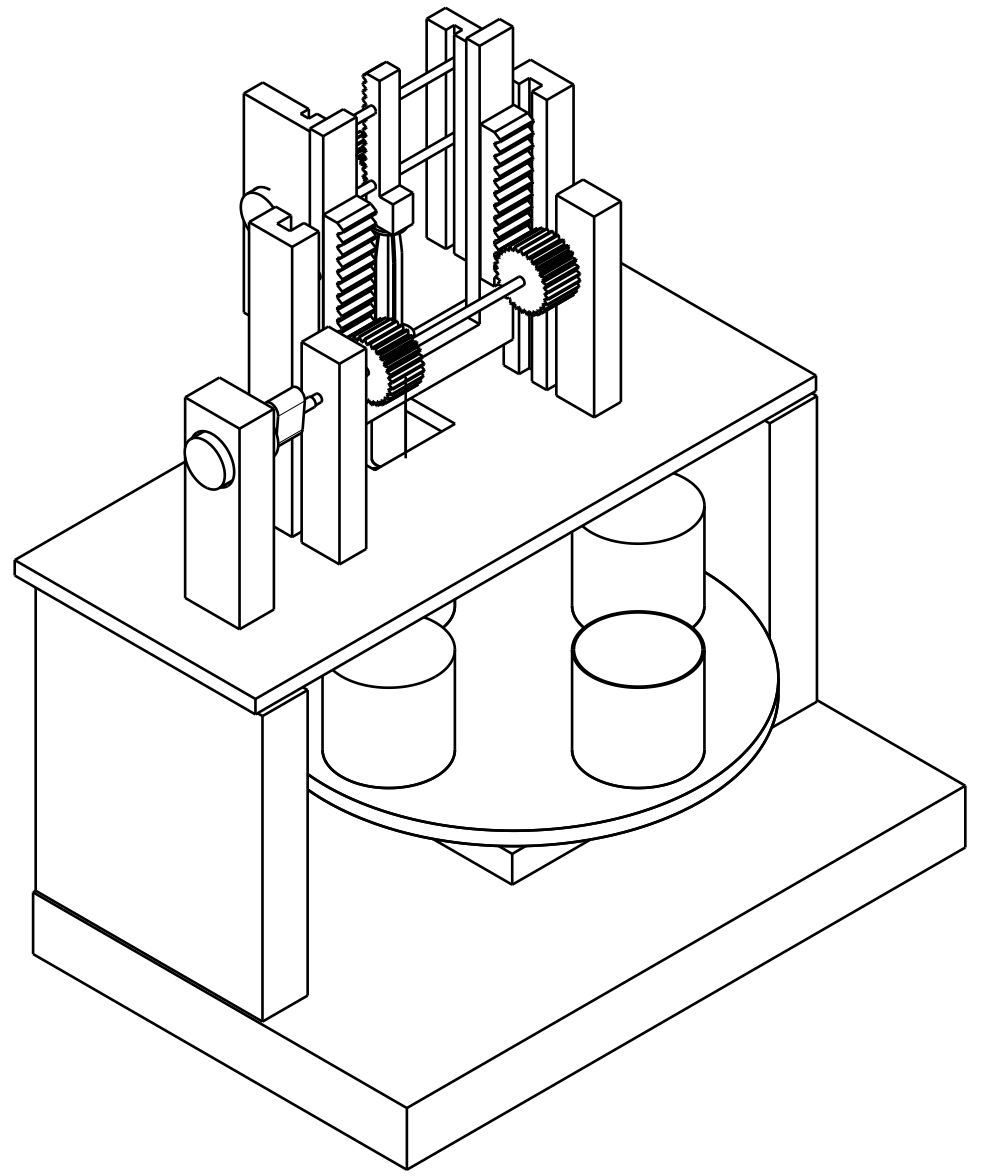
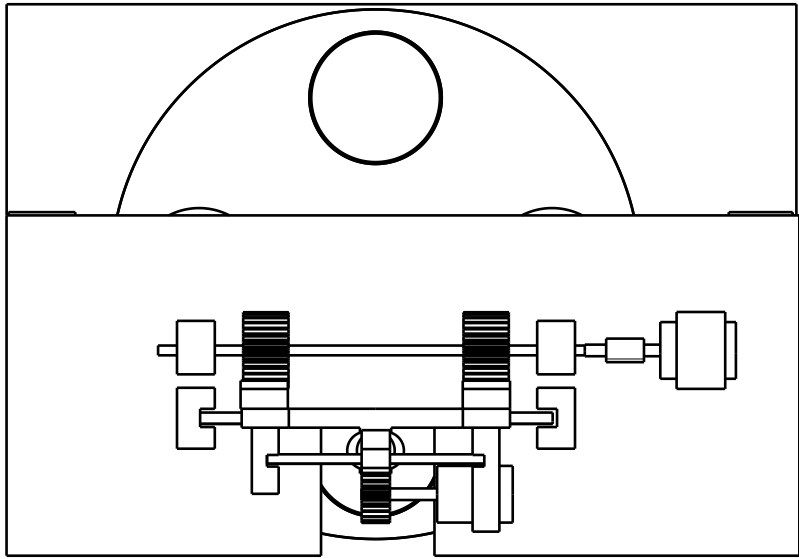

Isometric view
Scale: 1:4

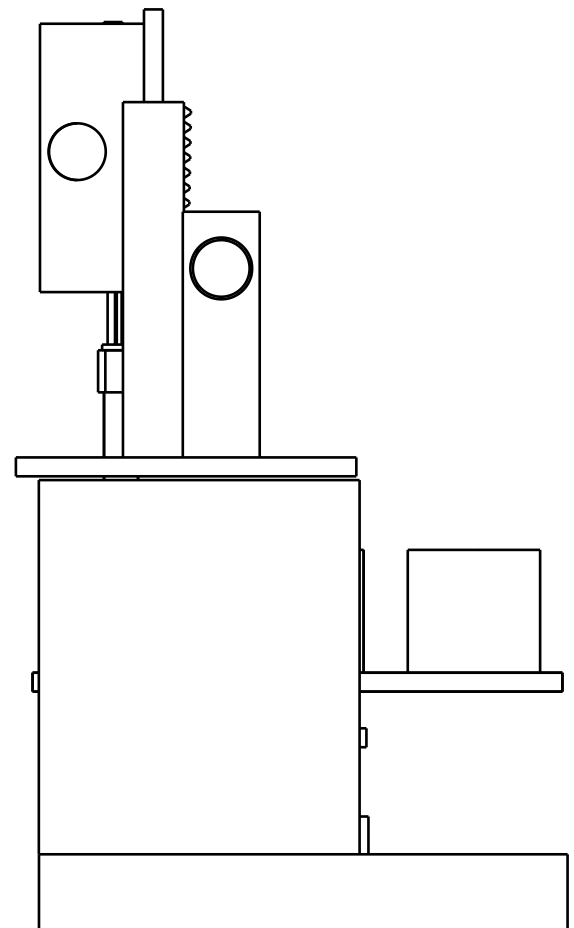
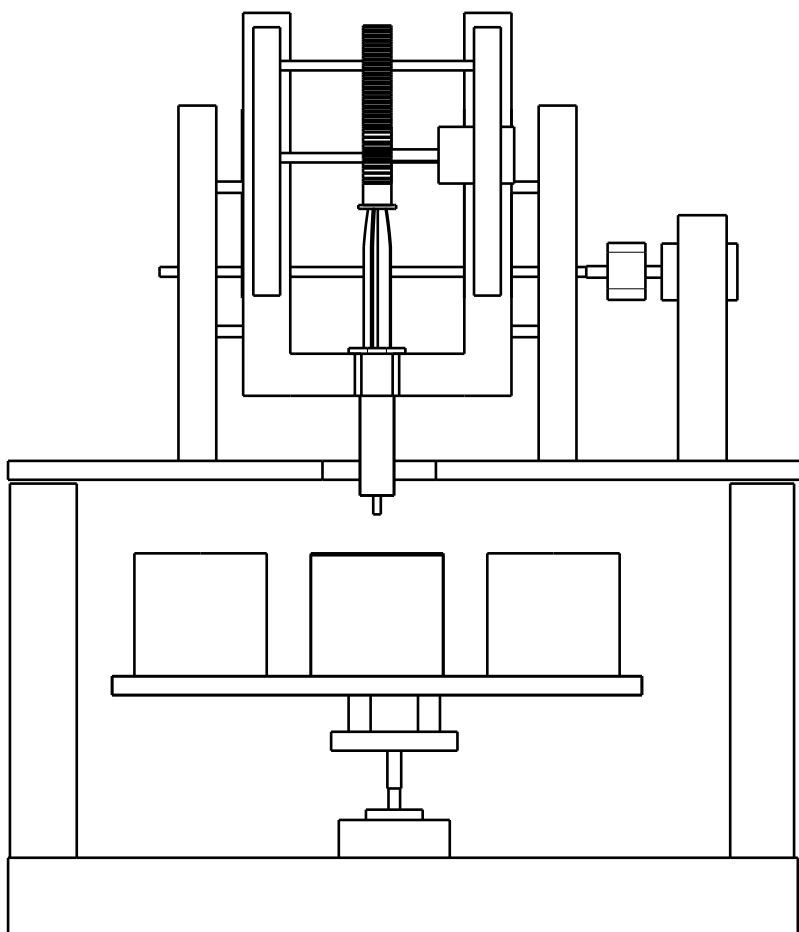

Assembly Drawing