

CHANNEL ESTIMATION IN MIMO WIRELESS ENVIRONMENT

Khatendra Yadav

Roll No: 212EC6198



Department of Electronics & Communication Engineering

National Institute of Technology

Rourkela

2014

CHANNEL ESTIMATION IN MIMO WIRELESS ENVIRONMENT

A THESIS SUBMITTED IN PARTIAL FULFILLMENT
OF THE REQUIREMENTS FOR THE DEGREE OF

Master of Technology

In

Signal and Image Processing

By

Khatendra Yadav

Roll No: 212EC6198

under the guidance of

Prof. L.P Roy



Department of Electronics & Communication Engineering

National Institute of Technology

Rourkela

2014

Declaration

I hereby declare that

- 1) The work presented in this paper is original and has been done by myself under the guidance of my supervisor.
- 2) The work has not been submitted to any other Institute for any degree or diploma.
- 3) The data used in this work is taken from only free sources and its credit has been cited in references.
- 4) The materials (data, theoretical analysis, and text) used for this work has been given credit by citing them in the text of the thesis and their details in the references.
- 5) I have followed the thesis guidelines provided by the Institute.

Khatendra Yadav

30th may 2014



NATIONAL INSTITUTE OF TECHNOLOGY ROURKELA
CERTIFICATE

This is to certify that the thesis entitled, “CHANNEL ESTIMATION IN MIMO WIRELESS ENVIRONMENT” submitted by Khatendra Yadav (212EC6198) in partial fulfillment of the requirements for the award of Master of Technology degree in Electronics and Communication Engineering with specialization in “Signal and Image Processing” at National Institute of Technology, Rourkela (Deemed University) and is an authentic work by her under my supervision and guidance.

To the best of my knowledge, the matter embodied in the thesis has not been submitted to any other university/institute for the award of any Degree or Diploma.

Date:

Prof. L. P. Roy
Dept. of E.C.E
National Institute of Technology
Rourkela-769008

ACKNOWLEDGEMENT

I am overwhelmed when I recall all the people who have helped me get this far. This thesis has been kept on track and been seen through to completion with the support and encouragement of numerous people including my teachers, my well-wishers, my friends and colleagues. I take this opportunity to thank these people who made this thesis possible and an unforgettable experience for me.

I would like to express my gratitude to my thesis guide **Prof. L. P. Roy** for her guidance, advice and constant support throughout my thesis work. I would like to thank her for being my advisor here at National Institute of Technology, Rourkela.

Next, I would like to express my respects to Prof. S. Meher Prof. Samit Ari, Prof. A. K. Sahoo, and Prof. U. K. Sahoo for teaching me and also helping me how to learn. They have been great sources of inspiration to me and I thank them from the bottom of my heart.

I would like to thank all faculty members and staff of the Department of Electronics and Communication Engineering, N.I.T. Rourkela for their generous help in various ways for the completion of this thesis.

I would like to thank all my friends and especially my classmates for all the thoughtful and mind stimulating discussions we had, which prompted us to think beyond the obvious. I've enjoyed their companionship so much during my stay at NIT, Rourkela.

I am especially indebted to my parents for their love, sacrifice, and support. They are my first teachers after I came to this world and have set great examples for me about how to live, study, and work.

Khatendra Yadav

Roll No: 212ec6198

ABSTRACT

Recently the increasing demand for improving channel capacity value attract the researcher to work in this direction and use MIMO wireless communication system. Researchers contribute various algorithms to improve the channel capacity in wireless communication. However, to achieve improved channel capacity we may need to have detailed knowledge of the channel. So in this work our aim is to estimate the channel in an MIMO wireless environment. The overview on basic techniques for channel estimation is given here. In this work, we estimate different channel parameters such as amplitude and phase and the results are compared with the ideal parameters. Here Maximum Likelihood Technique (MLE) is used to estimate the channel parameters.

TABLE OF CONTENTS

| | |
|---|------|
| DECLARATION | i |
| CERTIFICATE | ii |
| ACKNOWLEDGEMENT | iii |
| ABSTRACT | iv |
| TABLE OF CONTENTS | v |
| LIST OF FIGURES | vii |
| ACRONYMS | viii |
| 1.1 Introduction | 2 |
| 1.2 Basic Understanding of MIMO System | 2 |
| 1.3 Mathematical Description of MIMO System | 4 |
| 1.4 Advantages of MIMO | 7 |
| 1.5 Challenges of MIMO | 9 |
| 1.6 Channel State Information | 10 |
| 1.6.1 Introduction | 10 |
| 1.6.2 Mathematical Description of Channel State Information | 11 |
| 1.6.3 Estimation of Channel State Information | 11 |
| 1.7 Literature Review | 11 |
| 1.8 Outline of Thesis | 14 |
| CHAPTER 2 Statistical Estimation Techniques | 15 |
| 2.1 Introduction | 16 |
| 2.2 Brief Overview of various Estimation Techniques | 17 |
| 2.3 Application of Estimation Theory | 19 |
| 2.4 MLE (Maximum Likelihood Techniques) | 19 |
| 2.4.1 Introduction of MLE | 19 |
| 2.4.2 Principal of MLE | 20 |
| 2.4.2.1 Probability Density function | 20 |
| 2.4.2.2 Likelihood function | 21 |
| 2.4.2.3 Maximum Likelihood Estimation | 24 |
| 2.4.2.4 Likelihood equation | 24 |
| 2.5 Application of MLE | 26 |
| CHAPTER 3 Channel Estimation for MIMO System | 27 |
| 3.1 Introduction | 28 |

| | |
|---|-----------|
| 3.2 Channel Estimation by MLE Techniques | 28 |
| 3.3 Analysis of Channel Matrix | 31 |
| 3.3.1 Normalization of Channel Matrix | 31 |
| 3.3.2 Extraction of information from Channel Matrix | 32 |
| 3.3.3 Simultaneous Result | 32 |
| CHAPTER 4 Conclusion and Future work | 35 |
| 4.1 Conclusion | 36 |
| 4.2 Future Work | 36 |
| Bibliography | 37 |

List of Figures

| No. | | Page No. |
|-----|---|----------|
| 1 | MIMO Channel | 4 |
| 2 | Limitation in communication system | 8 |
| 3 | Binomial Probability Distribution where the sample size $n = 10$, probability Parameter $w = 0.2$ (top) and $w = 0.7$ (bottom) | 22 |
| 4 | The likelihood function for given observed data $y = 7$ and Sample size $n = 10$ for one parameter model | 23 |
| 5 | Empirical PDFs for the magnitude of the 10×10 H matrix Elements compared with Rayleigh PDF | 32 |
| 6 | Empirical PDFs for the Phase of the 10×10 H matrix Elements compared with Uniform PDF | 33 |
| 7 | Empirical PDFs for the magnitude of the 10×10 H matrix Elements compared with Rayleigh PDF | 33 |
| | Empirical PDFs for the Phase of the 10×10 H matrix Elements compared with Uniform PDF | 34 |

ACRONYMS

| | |
|------|-------------------------------------|
| MIMO | Multiple-Input-Multiple-Output |
| SISO | Single-Input-Single-Output |
| SIMO | Single-Input- Multiple-Output |
| MISO | Multiple-Input-Single-Output |
| CCI | Co-channel interference |
| ISI | Inter symbol interference |
| LOS | Line-of-Sight |
| CSI | Channel State Information |
| MVUE | Minimum-Variance-Unbiased-Estimator |
| BLUE | Best-Linear-Unbiased-Estimator |
| MLE | Maximum Likelihood Estimator |
| MCMC | Markov chain Monte Carlo |
| CRLB | Cramer-Rao Lower Bound |
| RBLS | Rao-Blackwell-Lehmann-scheffe |
| LSE | Least-square estimation |

CHAPTER 1

INTRODUCTION

1.1 Introduction:

Multiple Input Multiple Output (MIMO) communications techniques have been studied from a long time approximately more than one decade. It has been proved that theoretically that Communication system that use multiple antennas at both the transmitter and receiver have been the subject of much recent research because theoretically they offer improved capacity, coverage, reliability, or combinations compared to systems with a single antenna at either the transmitter or receiver or both [1],[2]. MIMO also offer different benefits, namely beam forming gain, spatial diversity and multiplexing. With beam forming, transmit and receive antenna patterns can be focused into a specific angular direction by the choice of complex baseband antenna weight. Under line-of-sight (LOS) channel conditions, R_x and T_x gains add up, leading to an upper limit of $m \cdot n$ for the beam forming gain of a MIMO system (n and m here the number of antenna elements for the receiver R_x and for the transmitter T_x respectively).

The increasing demand for capacity in wireless systems has motivating research aimed at achieving higher throughput on a given bandwidth. One important finding of this activity is that for an environment sufficiently rich in multipath components, the wireless channel capacity can be increased using multiple antennas on both transmit and receive sides of the link. Detailed performance judgment of space-time coding algorithms in realistic channels is mostly dependent upon accurate knowledge of the wireless channel spatial characteristics. To improve the gain that is possible with such systems which requires detailed knowledge of the MIMO channel transfer matrix. Algorithms that achieve this increased capacity actually use the multipath structure by cleverly coding of the data in both time and space [3].

1.2 Basic Understanding of MIMO System

The very basic first idea about MIMO (Multiple-input-Multiple-output) system found in the work of AR Kaye and DA George (1970), Branderburg and Wyner (1974), and W.van Etten (1975,1976) during the working on beam-forming application. The MIMO system first time introduced at Stanford University in 1994 and later at Lucent in 1996. Various authors purposed a various principal of MIMO system. Richard Roy and Bjorn Ottersten were proposed the SDMA (space division multiple access) concept of MIMO in 1991. While in 1993 arogyaswami

Paulraj proposed SM (spatial multiplexing) concept. In 1996 Greg der Raleigh and Gerard J. Foschini proposed new approach as in the one transmitter for improvise the link in effect we have to use more than one antenna in transmitter side which are co-located.

The function of MIMO can be classified into three different categories which are

1. Precoding
2. Spatial multiplexing
3. Diversity coding

Precoding- in the narrow sense Precoding is multi-stream beamforming. While in the wider sense Precoding consider all spatial processing which occur on transmitter. In single stream beamforming, we send same signal from each transmit transmitter and we take phase and gain of transmitted signals in such a way that it can maximize the signal power at the receiver. Beamforming used to add emitted signal from the transmitted antenna for increasing the gain of the signal which received at receiver. In Line-of-Sight (LOS) propagation, beamforming provide intensive explained direction pattern but for the cellular network conventional beam does not provide a good idea because it characterize by multipath propagation. When we arrange receiver with multiple antennas, transmit beamforming are not able to provide maximum signal strength among all receiver antennas, at this stage Precoding generally favorable. Precoding required the knowledge of channel state information at both end of communication system.

Spatial multiplexing- It require MIMO antenna system. In spatial multiplexing, high rate stream signal split in multiple low rate streams. Each stream transmits from different transmitter in same frequency channel. Spatial multiplexing used to increase the channel capacity at high signal to noise ratio. With the help of number of antennas which used at both and of communication link we can limit the maximum number of spatial stream. We can use spatial multiplexing without CSI at transmitter but if we want to use it with Precoding we have require CSI.

Diversity Coding- we used it when we have no knowledge of channel at transmitter. In this method, we transmit a single stream where we code the signal with the help of space-time coding. Diversity coding exploits independent fading to enhance the diversity of signal in multiple antenna system. If we have some knowledge of channel at transmitter, we can combine diversity coding with spatial multiplexing.

In Different forms of MIMO-

One is multi-antenna type called it as single user type. The special case of MIMO is SISO (single-input-single-output), SIMO (single-input-multiple-output), MISO (multiple -input-multiple -output). In MISO case receiver used only one antenna. While in SIMO case transmitter used only one antenna. The established/former radio system is a perfect example of SISO system. The SISO systems use single antenna at both transmitter and receiver. The some limitation on case is we have to select large physical antenna spacing.

Another is multi-user type. In the recent research, it found that multi-user (also called Network MIMO) can have high potential practically. Cooperative MIMO, multi-user MIMO are some class of multiuser type.

1.3 Mathematical Description of MIMO System

Basically MIMO stands for multiple inputs multiple outputs. It means multiple antennas on both the side of communication system which is transmitter and receiver.

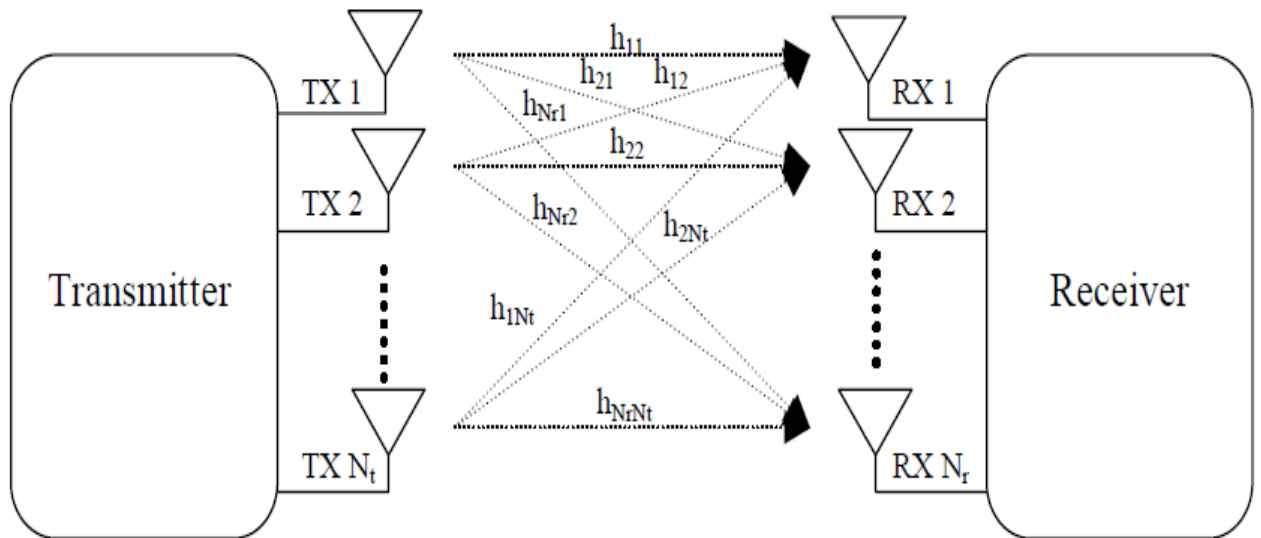

Fig. 1.1 MIMO Channel

Fig. 1.1 show above is the basic MIMO Channel block diagram. It shows multiple transmitters at transmit location and multiple receivers at receive location. The MIMO systems are able to increase the capacity of the communication channel in which the signals propagate. The channel matrix for the MIMO systems can be represents as

$$\mathbf{H} = \begin{bmatrix} h_{11} & \cdots & h_{1N_T} \\ h_{21} & \cdots & h_{2N_T} \\ \vdots & \ddots & \vdots \\ h_{N_R1} & \cdots & h_{N_RN_T} \end{bmatrix} \dots\dots\dots (1.1)$$

The format of channel matrix which is providing in equation (1.1) shows the many elements in between transmitter and receiver. These elements are channel gains or complex fading coefficient between transmitter and receiver. We are assuming here that the gains are independent and identically distributed and based on Gaussian random variable have zero mean and unit variance. We are transmitting frame by frame. In between the frame the channel does not change. When the frame of transmitted signal are change the channel are also change. In between the communication system when the channel travels so many obstacles presents which makes the multipath for input transmission signal. So, the received signal at the receiver is the sum of these entire multipath signals.

From the information theory, we can represent the channel capacity of MIMO System when the transmitter and the receiver kept instant channel state information as

$$\begin{aligned} C_{perfect-CSI} &= E[\max_{q:tr(q) \leq 1} \log_2 \det(I + \rho \mathbf{H} \mathbf{Q} \mathbf{H}^H)] \\ &= E[\log_2 \det(I + \rho \mathbf{D} \mathbf{S} \mathbf{D})] \dots\dots\dots (1.2) \end{aligned}$$

Where $()^H =$ Hermitian transpose

$\rho =$ transmit SNR (ratio between transmit power and noise power)

We can achieve optimal covariance of the signal ($Q = VSV^H$) by singular value decomposition (SVD) of the channel matrix ($UDV^H = H$) and optimal diagonal power allocation matrix ($S = \text{diag}(S_1, \dots, S_{\min(N_t, N_r)}, 0, \dots, 0)$). We can achieve optimal power allocation by waterfilling [24], which is

$$S_i = \left(\mu - \frac{1}{\rho d_i^2} \right)^+ ; i = 1, \dots, \min(N_t, N_r) \dots \dots \dots (1.3)$$

Where $d_1, \dots, d_{\min(N_t, N_r)}$ = Diagonal element of D, $(.)^+$ Is zero if its argument is negative. We select μ in prenominal way that it satisfy $S_1 + \dots + S_{\min(N_t, N_r)} = N_t$

If transmitter kept only statistical channel state information then the channel capacity will decrease. The capacity decreases as signal covariance Q could only optimize in terms of average mutual information.

$$C_{\text{statistical-CSI}} = \max_Q E[\log_2 \det(I + \rho H Q H^H)] \dots \dots \dots (1.4)$$

With the statistical information the correlation affect the channel capacity. if transmitter is no channel state information. It can select signal covariance Q for maximize channel capacity.

This take place under worst-case statistics that means $Q = \frac{1}{N_t} I$

$$C_{\text{no-CSI}} = E \left[\log_2 \det \left(I + \frac{\rho}{N_t} H H^H \right) \right] \dots \dots \dots (1.5)$$

With the statistical properties of channel, channel capacity is no more than $\min(N_t, N_r)$ times greater than of a SISO system.

1.4 Advantages of MIMO antenna system

Wireless channel provide some limitation in communication system which is shown below in Fig 1.2 and explained. In the wireless transmission the major limitations are

1. Noise: Thermal noise create problem in transmission which effect on electronic instruments. By this the efficiency of instruments gets low. Also by the increased noise the noise power increased which reduced the signal to noise ratio and by this effect the signal to noise ratio reach in limited state. By the noise affect the strength of signal increase or decrease in a random manner.
2. CCI: CCI stands for co-channel interference. It is a cross talk on different transmitter on the same radio frequency. During poor weather we can see this effect on cellular communication. It mainly occurs when the radio frequency distribution has some problem and radio spectrum provide adverse effect by crowded scenario. When we allocate the radio spectrum in a right manner than this problem can be decrease.
3. ISI: It stands for inter symbol interference. It occurs mostly in telecommunication. In the communication system when we transmit the signal from the transmitter then in between the signal interface with other signal. This interference occurs in symbols of signals. It produced distortion like noise. It also occurs on multipath propagation and band limited signal. ISI effects on eye pattern. In band-limited signal it can be avoided by pulse shaping. The ISI can be minimizing by making impulse response so smaller. By the minimization of impulse response the transmitted bit are not able to overlap.
4. Fading: In the communication system fading refers the decrease in the signal strength. Fading is a random phenomenon, so it does not depend on time. Either by multipath propagation or by wave propagation it comes. Fading classified into different category like slow and fast fading, selective and frequency selecting fading etc. fading effect changes the amplitude and phase of transmitted signal.

MIMO systems which used at both transmitter and receiver side are capable to reduce all these limitation in a certain extend. Due to gain of spatial multiplexing the communication channel capacity improves. The increased capacity does not take more power as well as bandwidth.

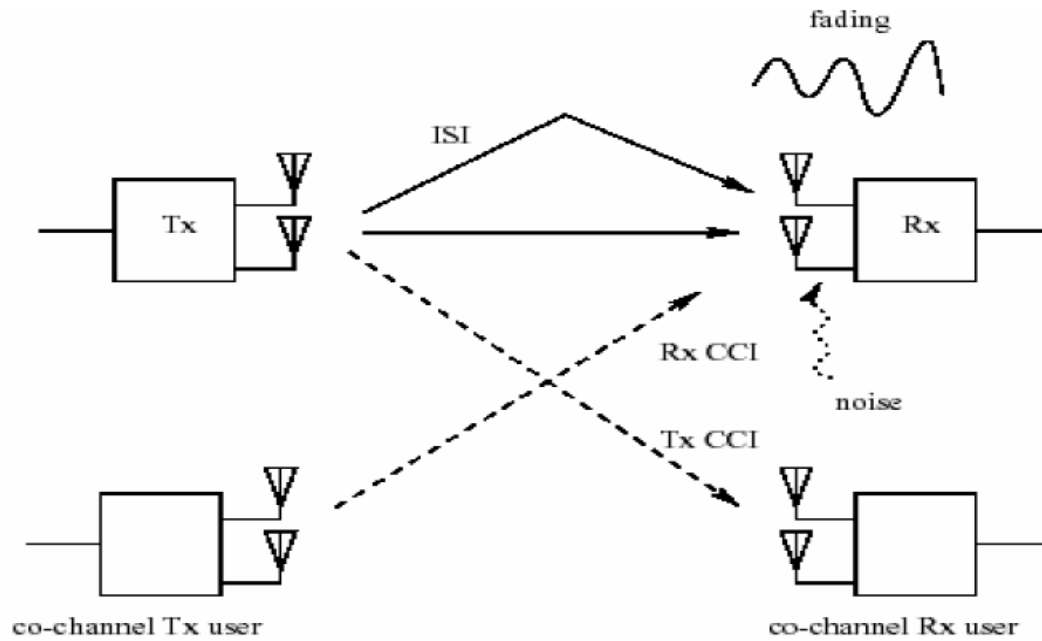

Fig 1.2

While by the diversity gain we can see the improvement in reliability. By the antenna array system the output signal to noise ratio is more than N times input signal while N stands for noise power. So we can see that by these and by many more parameter increases many limitation of wireless communication.

We used MIMO system mostly in wireless communication (WLAN, Wi-Fi, WI-Max). The MIMO system has the capacity in the improvement of data while the distance between antennas, signal strength, noise in the environment are major concern. The channel capacity has some limit. This limit is shown by Shannon in his theorem which is

$$Capacity = BW \log_2(1 + SNR).....(1.6)$$

By this equation it is clear that the channel capacity is ultimate depends upon channel Bandwidth and signal to noise ratio. The signal bandwidth can be increased by bit-rate/symbol rate of modulating signal. The MIMO antennas system used multiple antennas at transmitter as well as receiver. By this increased antennas model not only we can improve our channel capacity but high data rate also. For example the 4 x 4 antenna system produce double spatial stream

compared to 2 x 2 antennas system as well as by four times compared to 1 x 1 antennas system. The 1 x 1 antennas system called the traditional antennas system.

The Benefits of MIMO can be pointed out as

1. It has under water application as sonar communication.
2. It is used in RADAR application, it increase the Beam-forming.
3. It can be used as Broadband.
4. It can be used in multimedia cases alike video and more many.
5. It can also use in home, office, moving object and moving to stationary object.
6. It has the ability to provide multiplexing gain.
7. It can increase the signal to noise ratio by some constant factor.
8. We can get the maximum diversity gain by MIMO system.
9. In the capacity issue the SISO (single input-single output) based on SNR. While in MIMO cases the capacity improved by less antennas. The growth rate of capacity in MIMO is linear compared to SISO.
10. The MIMO use less power for transmission. It removes the interference in the channel and increases the signal strength. By the increased strength of signal the signal provide better efficiency. The users and ranges are also improved.

1.5 Challenges in MIMO system

1. Larger MIMO- more than hundred low power antenna (approximately 1mW) places on a Base station to increase the performance of MIMO system.
2. Estimation of practical impairment- in practical communication system major factor like timing offset, phase shift, frequency offset affect the system performance. The estimation of these several factors as well as the compensation of these factors are a major challenge
3. MIMO relaying network- Combined the cooperative and MIMO technologies to increase the channel capacity, coverage area and channel reliability
4. Reduce the hardware and software complexity, thermal problem due to increase antenna structure on both side of antenna of the MIMO system

5. Reduce the Antenna spacing problem which occur difficulty in MIMO communication.
6. Heterogeneous network- combined the macro-cell, Pico-cell and femto-cell together to increase indoor coverage as well as power efficiency
7. Multicell MIMO- equipped multiple base station with multiple antenna is a main challenge in interference mitigation
8. Reduce the problem of power consumption

1.6 Channel State Information (CSI)

1.6.1 Introduction

In wireless communication, identified channel attributes of a communication link called channel state information. The channel state information gives total knowledge of signal propagation. How the signals transmit from the transmitter and reach to receiver. The phenomenon which face by the signal in communication channel alike scattering, diffraction, power delay and many more are explain by channel state information. The CSI require estimation at the receiver and generally quantization and feedback for transmitter. So, we can conclude that the transmitter have different CSI with respect to receiver. The CSI for the transmitter can be expressed as CSIT and for the receiver CSIR as well.

Basically for CSI two stages are which is

1. Short term CSI-also called as instantaneous CSI. It show current channel circumstance which we know. We can view this by impulse response of a digital filter. It provides possibility to conform the transmitting signal for impulse response. So by this we make optimal receive signal for two things. The first one is spatial multiplexing or the second one low bit error rate.
2. Long term CSI-also called as statistical CSI. It show the statistical characteristics of the channel which we know. This statement can include, for example in the fading distribution we include fading disturbance, line of sight element and correlation.

1.6.2 Mathematical Description of CSI

We can model the MIMO system as

$$y = Hx + n \dots \dots \dots (1.7)$$

Here y = receive vector; x = transmit vector; H = channel matrix; n = noise vector

Frequently noise modeled as complex normal distribution which express as

$$n \sim \text{cN}(0, S), \text{ Here mean} = 0, \text{ noise covariance matrix} = S$$

Short term CSI / instantaneous CSI- in ideal case we know channel matrix H absolutely. So we can express the channel information as

$$\text{vec}(H_{\text{estimate}}) \sim \text{cN}(\text{vec}(H), R_{\text{error}})$$

Here H_{estimate} = channel estimation; R_{error} = estimation error covariance matrix, to mess the column of H we used $\text{vec}()$ because multivariate random variable generally defined as vector.

Long term CSI / statistical CSI- in this CSI case we know the statistics of channel matrix H . In Rayleigh fading channel, this comparable to knowledgeable that

$$\text{vec}(H) \sim \text{cN}(0, R) \text{ For some channel covariance matrix which referred as } R.$$

1.6.3 Estimation of CSI

Because the channel varies with the time so we have to estimate the CSI for a short term. The mostly use overture pilot sequences we used here. We know the transmitting signal and with the full knowledge of transmitter and receiver we estimate channel matrix.

We are denoting pilot sequences as P_1, \dots, P_N

Here P_i = transmitted vector over channel

With the combination of receive pilot sequences total pilot signaling becomes

$$Y = [y_1, \dots, y_N] = HP + N$$

Here pilot matrix $P = [P_1, \dots, P_N]$; Noise matrix $N = [n_1, \dots, n_N]$

From the notations which are showing here mean, channel should estimate from cognition of Y and P. here for the estimation we are using least-square estimation techniques

Here the channel as well as noise dispersion are unknown so we can represented the least-square estimator (or also called minimum variance unbiased estimator) as

$$H_{LS-estimate} = YP^H (PP^H)^{-1}$$

Here $()^H$ show conjugate transpose. The estimation mean square error proportional to $tr(PP^H)^{-1}$, here tr shows the trace. The error will be minimizing when we ordered PP^H to identity matrix. It will be achieve when N is greater than or equal to number of transmitting antenna.

1.7 Literature review:

In this literature review basic idea of several methods for channel estimation are shown. Steven Howard, Hakan Inanoglu and John Ketchurn did an outdoor channel measurement for MIMO system. By using the wideband channel sounder they derive the channel impulse response for each transmitter-receiver pair. They calculated the different Correlation matrix for different times. They consider the fading affect into their experiment and proved that where the signal fading is non-correlated/Rayleigh the channel capacity is more compared to correlated/non-Rayleigh case [1], [5]. Jerry R. Hampton, Manuel A. Cruz and Naim M. Merheb measure the channel for urban military environment. They took two paths between transmitter and receiver ‘LOS (line of sight) path and L shape path’ for channel measurement. They measured data and by the uses of these data they derive channel transfer matrix and channel capacity. The capacity of channel is a function of antenna spacing between transmitter and receiver. This measured capacity is 1.3 or 1.8 times higher than theoretical capacity. The increment on antenna spacing shows no improvement in channel capacity [2].

In both the experiments that explain above it has been prove that fading correlation affects the capacity of MIMO system. It means if the fades between transmitter-receiver antenna pair is i.i.d (independent, identically distributed) the MIMO system offer a large channel capacity between compared to single transmitter-receiver system. There have done much work regarding the fading effect on channel capacity. One is ray-tracing simulation another is construct a scatter model [6], [10]. But the problem with them is that in MIMO antenna system they have not address the model of fading and effect of this on channel capacity. So Da-shan shiu, Member, IEEE and Gerard J. Foschini by extension of “one-ring” model which is first proposed by jakes [5] and have seen the effect of fading on channel capacity.

Matthias Lieberei, Udo Zolzer estimate the MIMO channel with different and environments. They measure the MIMO channel in different environment and see the effect of these channels on spatial correlation, temporal correlation and channel capacity. They used space aircraft carrier in their environment. The delay spread is also explained by the author in their experiment [9]. C. Jandura, R. Fritzsche, G. P. Fettweis, and J. Voigt explain the MIMO channel analysis in urban area. They explained channel characteristics. Authors used the advanced ray tracing simulations method in their experiment and used the 2.53 GHz frequency for their experiment. The experiment was under of EASY-C project and the motive of these to know about multi-point coordination. The author objective of that experiment was to find-out the physical structure on wireless channel. They show that the capacity improvement is good in urban area [10].

In the starting of cellular communication path loss and fades effect are the major parameter to find out channel performance in any environments. But with the spending of time many other parameters used to find-out the performances. The some parameters are polarization, directivity, antenna gain, multi antenna system on both the end of communication. So the authors Nicolai Czink, Alexis Paolo Garcia Ariza in their measurements explained these all things and effects on channel estimation well. They used outdoor, indoor and indoor-outdoor combination for their experiments.

Jon W. Wallace, Michael A. Jenson and Ajay Gummalla time varying MIMO channel are estimate for an outdoor environment. This experiment is done at 2.45 GHz frequency. The resultant data that collected from experiment used to express their behavior in form of channel

temporal variation. Some matrixes are generated so that variation of time on MIMO channel can be easily shown. And also matrixes also used to show system performances in time variation form. This analysis is very useful in in MIMO system mobile communication [11].

1.8 Outline of Thesis

In this chapter introduction of MIMO, Advantages, Challenges, Application of MIMO, Channel state information are discussed.

In chapter 2 Brief overview of various estimation techniques are given. And discussion on Maximum Likelihood techniques (MLE) is also given.

In chapter 3 Channel estimation of MIMO wireless environment by MLE are discussed.

Chapter 4 provided conclusion of present work and future work prediction which will have to done in future.

CHAPTER 2

Statistical Estimation Techniques

2.1 Introduction

Estimation Theory is a one important branch of statistics from various branches. The estimation theory deals with estimate value of parameter which is based on measured data and which has random ingredient. The parameter which we want to identify in estimation theory should be such like that the value of this parameter affect the dispersion of measured data. An estimator is about to approximate the unknown parameter using the measurement.

For example, in the radar system our intention is to find-out or to estimate the range 'R' of an object. To estimate the range 'R' of radar we send an electromagnetic pulse from the transmitter that pulse after reflecting from target produce an echo which received by the antenna after some time delay. The reflected pulses from the object are necessity enclosed in electrical noise. The measured data are distributed in random order so for the calculation of transit time we required estimation.

The main motive of estimation theory is to come on an estimator. This should be implementing in an easy manner. The estimator which we want to implement used evaluate data as an input. This estimator gives an estimate of this parameter with comparable accuracy. We always prefer such kind of estimator which expose optimality and show maximum accuracy. The optimality of an estimators show less amount of average error. Though this error only for some course of estimator. For example - Minimum-Variance-Unbiased-Estimator (MVUE)

In the case of MVUE the division is an exercise of unbiased estimator. While average error criterion is variance (variance quantify that how far the set of data are spread). Nevertheless, the optimal estimator always does not exist. Problem of statistics is not to find estimates of the evaluate data but to find estimators. Estimator is not rejected because one estimator gives bad result for one sample. It is rejected when it gives bad results in a long run i.e. it gives bad result for many, many samples. Estimator is accepted or rejected depending on its sampling properties. Estimator is judged by the properties of the distribution of estimates it gives rise. Mostly the estimator should be efficient and unbiased as well.

2.2 Brief Overview of various Estimation techniques

There is some general step to find out an estimator-

1. To find out a coveted estimator, in the very first step from the measured data we calculate the probability density function. This density function formed from physical model which in an explicit manner show the relation between estimated parameter and measured data and how the noise effect these data.
2. After decided the model of this probability density function, the very basic thing which would be very useful to find out the precision of any one of estimator which is theoretical achievable. We can use Cramer-Rao Lower Bound for this processing.
3. In the next step, we have to develop an estimator or apply an estimator. If anyone estimator which previously known is valid to this model then at this stage we apply the estimator. There are many different methods for deriving the estimator.
4. In the final, experiments or simulation methods can be used to check the performance of an estimator.

Estimation theory can be applied linear model as well as nonlinear model. This theory is in a very close relation to both system designation and nonlinear system designation.

Commonly used estimation techniques or estimators are

1. Minimum variances unbiased estimators (MVUE)
2. General Minimum variances unbiased estimators
3. Best linear unbiased estimators (BLUE)
4. Maximum Likelihood estimators (MLE)
5. Bayes estimators
6. General Bayesian estimators
7. Linear Bayesian estimators
8. Kalman Filters
9. Wiener Filters
10. Markov chain Monte Carlo (MCMC)

In statistical signal processing basically we divide the estimator into two type unbiased estimator and biased estimator. Unbiased estimators give the true value of estimated parameter while the biased estimators provide some error in estimation. So we always try to find out an unbiased estimator for any problem. The various type of unbiased and biased estimator are The Minimum variance unbiased (MVU) estimators is an unbiased estimators which is having lower variance compared to any other unbiased estimators for all existing values of parameter. If any unbiased estimators which gives variance same as Cramer-Rao Lower Bound (CRLB) such kind of estimator called as minimum variance unbiased estimators. Here CRLB show a lower bound. The lower bound is on variance of estimators of a settled parameter. In the rating of CRLB at some time the results efficient. So that estimator is MVU estimators. Nevertheless, effective estimators do not exist. So it is also a one of most interesting thing find out the MVU estimator. For such estimation we have required Rao-Blackwell-Lehmann-scheffe (RBLs) theorem. By use of this theory we can estimate the MUV estimator by only simple examination. In some estimation problem when we find to estimation the linear data. At that time the question comes that which estimator provide estimation for linear function. The answer looks very clear; the functions which make such estimator are best linear unbiased estimator (BLUE). So, BLUE is unbiased, worked as linear function and also having minimum variance. The maximum likelihood estimator or MLE used mostly in practical and based on maximum likelihood principal. Least square estimation or LSE is estimation process when we have no knowledge about probability. So, LSE is wholly deterministic approach. The moment of method is another estimation technique. It uses simple optimizing approach in entity without any optimality property. It uses to work on larger data samples size. With it, we used it in initial estimation for algorithm. For example- iterative searching of MLE

The Kalman filter is a recursive estimator means it estimates form previous time sample and current time sample for computation current state. It is a most simple dynamic Bayesian network. It estimates the true value of state recursively overtime. It uses incoming measurement and mathematical process model. In statistics, Markov chain Monte Carlo (MCMC) method is a class of algorithm for sampling from probability distribution. It is based on constructing a Markov Chain that has desired distribution as its equilibrium distribution.

2.3 Application of Estimation Theory

Numerous fields used the estimation techniques. Some of fields are-

1. Signal processing
2. Adaptive control theory
3. Telecommunication
4. Opinion polls
5. Software engineering
6. Project management
7. Clinic trials
8. Quality control
9. Orbit determination
10. Network intrusion detection system

2.4 Maximum Likelihood Estimation

2.4.1 Introduction of maximum-likelihood estimation (MLE)

In psychology, we seek to uncover general law and principles that govern the behavior under investigation. These general laws and principles calculated and analyzed in terms of hypotheses because they are not directly observable. In mathematical modeling, these hypotheses are the structures and internal working off probability distribution families, that we called models.

Once when we specified model and its parameter and data have been collected from experiment. The very basic problem is this time is how we can fit this data very well. The basic procedure for best fitting of this data is called *parameter estimation*.

There are two general methods of parameter estimation first one is least-squares estimation (LSE) and another is maximum likelihood estimation (MLE). The least-squares estimation (LSE) is a standard choice to find out approximate solution for over-determined system. Over-determined system means the more than three equations set those are unknown. The LSE method minimizes the sum of the squares of the errors which made in the results of

every single equation. It is a very popular choice in psychology. Their uses are in linear regression, sum of squares error, proportion variance accounted, root mean squared deviation etc.

On the other side, MLE is not as much used in psychology as in statistics. MLE is a standard method to find out parameter estimation in statistics. This method is a popular one method in estimation of model parameter. When we applied a given data set and statistical model, the MLE method gives the estimate values of this parameter. MLE has no optimal properties for finite sample but it possesses some limiting properties as consistency, asymptotic normality, efficiency and so more [6]. Application of MLE in statistical area is curve fitting, linear model, generalized linear model, and structure equation modeling etc. while in the other fields are econometrics, psychometrics, communication system, geographical satellite-image classification etc.

2.4.2 Principle of Maximum Likelihood Estimation with Suitable example

2.4.2.1 Probability Density function

From a statistical point of view the data is identified by probability distribution. The models parameter has unique value of each probability distribution. A change in the values of model parameter generates new probability distribution. Let $f(y|m)$ show the probability density functions which represent probabilities of observed data vector y given the parameter w . throughout this principle, we will use for a vector and for a vector element plain letter and letter with subscript respectively (e.g. for vector X , for vector element X_i). The parameter $w = (w_1, w_2, \dots, w_k)$ shows a vector into a multi dimension space. While in the individual observation, y_i 's are statistically independent from another. So by the probability theory, the PDF for $y = (y_1, y_2, \dots, y_n)$ given the parameter vector w can be expressed as a multiplication of PDFs for individual observations.

$$f(y = (y_1, y_2, \dots, y_n) | w) = f_1(y_1 | w)f_2(y_2 | w)\dots\dots f_n(y_n | w)\dots\dots(2.1)$$

To understand the idea of a PDF we are taking into consideration a simplest case. In this case we are taking single observation and single parameter. That means $m=k=1$, assume that the data y here representing the number of success in the succession of 10 Bernoulli trials (for

example-toss a coin 10 times is a Bernoulli trial). And the probability for the succession of 1 trial whatsoever, we represent it by parameter w which is 0.2. So, in this case we can represent the PDF as

$$f(y | n = 10, w = 0.2) = \frac{10!}{y!(10 - y)!} (0.2)^y (0.8)^{(10-y)} \dots\dots\dots(2.2)$$

Where $y = (1,2,\dots,10)$

This Distribution is called as a binomial distribution. Where the parameter are $n = 10, w = 0.2$. Here we are considering the number of trial as a parameter. The shape of PDF which is represented in equation (2.2) given below in figure 2.1. With the change in the parameter value w we can obtain new PDF. In the new parameter case ($w=0.7$) we can represent the PDF as

$$f(y | n = 10, w = 0.7) = \frac{10!}{y!(10 - y)!} (0.7)^y (0.3)^{(10-y)} \dots\dots\dots(2.3)$$

Where $y = (1,2,\dots,10)$

The shape of this PDF is shown into the bottom of figure 2.1. The general formula for the PDF of the binomial distribution for any values of w and n can be represented as

$$f(y | n, w) = \frac{n!}{y!(n - y)!} (w)^y (1 - w)^{(n-y)} \dots\dots\dots(2.4)$$

$(0 \leq w \leq 1; y = 0,1,\dots,n)$

The equation 2.4 is a function of y where the values of n and w are given. If we collect all these PDF which we bring forth to vary the parameter crossway its range $(0 \leq w \leq 1, n \geq 1)$ define a model.

2.4.2.2 Likelihood function

The corresponding PDF for a set of parameter value shows that some data are more probable than other data. From the given observed data and one model we find out one PDF from

all the probability density of which the probability model are prescribe that most likely to produced data. So we faced an inverse problem and to solve this, we defined a likelihood function by reverse the given data vector y and parameter vector w in $f(y | w)$, i.e.

$$L(y | w) = f(y | w) \dots \dots \dots (2.5)$$

So, $L(y | w)$ represents the *likelihood function* of the parameter w and the observed data y which is defined on parameter scale.

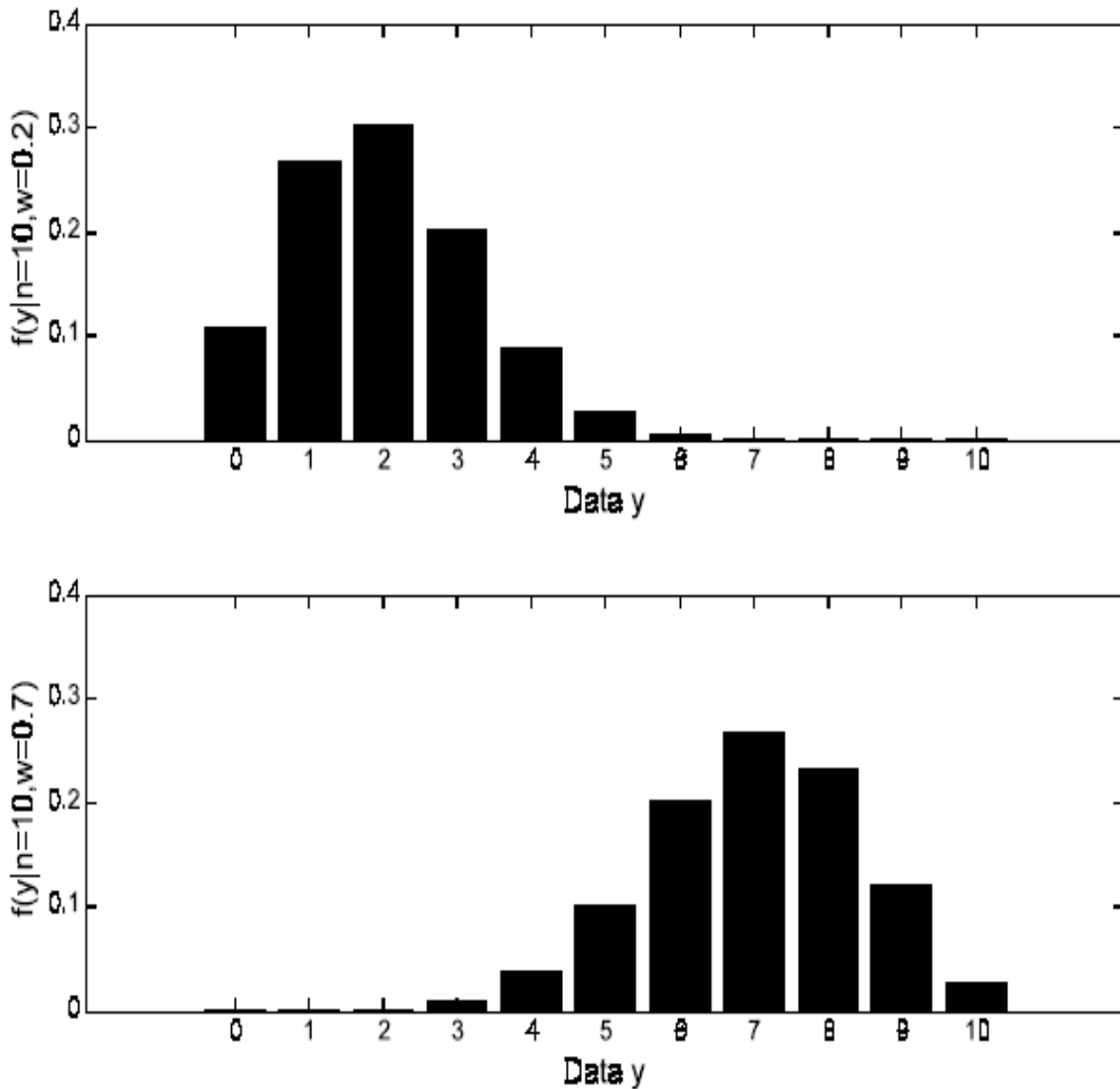

Fig 2.1 Binomial Probability Distribution where the sample size $n = 10$, probability parameter $w = 0.2$ (top) and $w = 0.7$ (bottom)

In the previous example the one-parameter binomial example by the equation 2.4, the likelihood function for $y = 7$ and $n = 10$ can be represented as

$$L(w | n = 10, y = 7) = f(y = 7 | n = 10, w) = \frac{10!}{7!3!} w^7 (1-w)^3 \quad (0 \leq w \leq 1) \dots \dots (2.6)$$

The likelihood function which is represented in equation (2.6) can be shown in figure (2.2) which is given below. There are important differences between the two function $L(y | w)$ and $f(y | w)$. Because these two different functions are defined on different axis so we cannot compare it directly. Fig 1 shows the probability of a specific data while the Fig 2 shows the likelihood of a specific parameter value to a fix data. The likelihood function which is show in Fig 2 is a curve because next to n there only one parameter. If model has kept two parameters than, the likelihood function would a surface which sits above parameter attribute. So in general we can say like this way-

The likelihood function changes according to parameter. If the likelihood function has k -parameters then this function takes shape of k -dimension geometrical surface. This surface is sitting on a k -dimension hyper plane that spanned by parameter vector $w = (w_1, w_2, \dots, w_k)$.

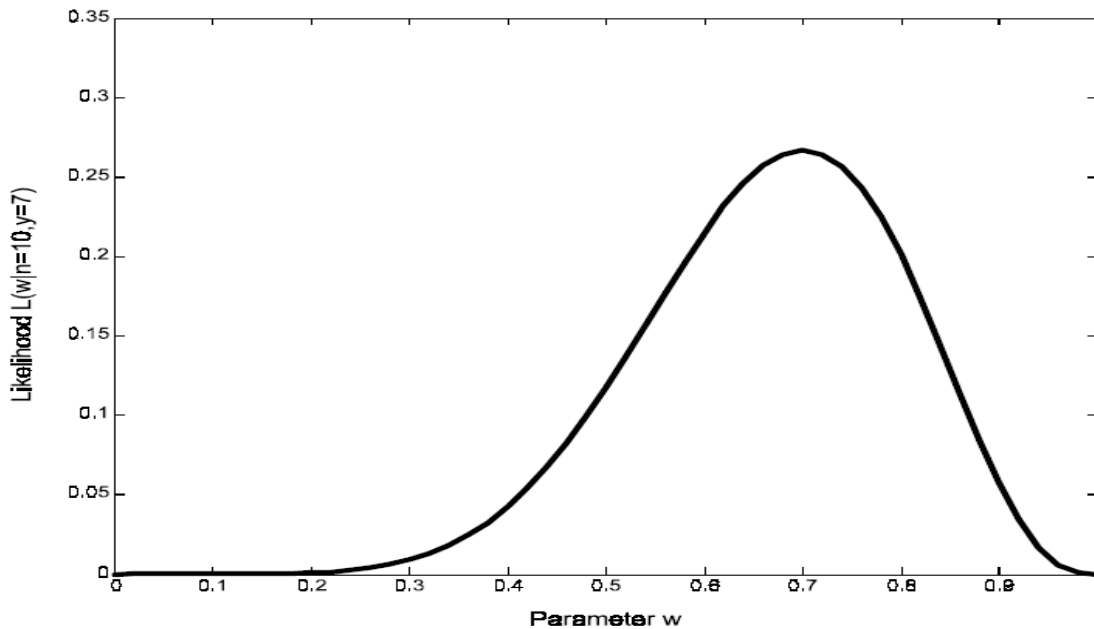

Fig 2.2 The likelihood function for given observed data $y = 7$ and sample size $n = 10$ for one parameter model

2.4.2.3 Maximum likelihood estimation

After collection of data and determine the likelihood function for a model we are interested in finding the parameter value that corresponds to the desired probability distribution. In the Fig 1 different probability distribution are given, from these distributions we are showing interest to find-out the parameter values which match with craved probability distribution.

R.A.Fisher developed the principle of MLE (Maximum Likelihood estimation). This used to make the data most likely, the data are observable data. So, we have to seek the values of the parameters that maximize likelihood function $L(y | w)$. The resulting parameters vectors in the multi-dimensions space, called the MLE estimation. And is denoted by

$$w_{MLE} = (w_{1,MLE}, w_{2,MLE}, \dots, w_{k,MLE})$$

For example, in the Fig 2, the MLE estimator is $w_{MLE} = 0.7$ which maximize the likelihood value of $L(w_{MLE} = 0.7 | n = 10, y = 7) = 0.267$. The PDF with respect to this MLE is shown in the bottom of Fig 1. In the summary we can conclude that MLE is methods for desire to probability distribution which oversimplify observe data maximum likely.

2.4.2.4 Likelihood equation

MLE if they exist, they are unique. For computational convenience, to estimate the MLE we have to maximizing the log-likelihood function which is $\log(L(y | w))$. Because the functions $L(y | w)$ and $\log(L(y | w))$ are monotonically related to each other, so, if we maximize any one, we get same MLE. According to probability theory $\log(L(y | w))$ is differentiable, if w_{MLE} exist. So, it has to satisfy partial differential equation.

$$\frac{\delta(\log(L(w | y)))}{\delta w_i} = 0 \quad \dots \quad (2.7)$$

At $w_i = w_{i,MLE}$ for all $i = 1, 2, \dots, k$

The partial differential equation which is given above partial differential equation knows as *likelihood equation*. The condition “at $w_i = w_{i,MLE}$ for all $i = 1, 2, \dots, k$ ” is given because according to the definition the first derivative of given partial differential equation becomes equal to zero at these point.

The likelihood equation given in equation (2.7) is a necessary condition for the existence of MLE. And one more condition that $\log(L(y | w))$ is maximum or minimum, to find out this

the shape of the function should be convex that means it has to represent a peak not a valley. This can be checked by first derivative of given partial differential equation or second derivative of log-likelihood function. If they are showing negative values at $w_i = w_{i,MLE}$ for all $i = 1, 2, \dots, k$

$$\frac{\delta^2(\log(L(w|y)))}{\delta w_i^2} < 0 \dots\dots\dots (2.8)$$

Here, let us we are again considering the previous one parameter binomial example for a fixed value of n. So, in the first we take the logarithm which gives into equation 2.6, after the logarithm the likelihood function looks like as

$$\ln L(w | n = 10, y = 7) = \ln \frac{10!}{7!3!} + 7 \ln w + 3 \ln(1 - w) \dots\dots\dots (2.9)$$

In the next, we are deriving the log likelihood function which show into equation (2.9) and express the deriving function as

$$\frac{d}{dw} \ln L(w | n = 10, y = 7) = \frac{7}{w} - \frac{3}{1 - w} = \frac{7 - 10w}{w(1 - w)} \dots\dots\dots (2.10)$$

By putting equation 2.10 equal to zero the craved MLE obtain as $w_{MLE} = 0.7$. To show that this desire MLE represent a maximum we are taking again derivative of first derivative of log-likelihood function. After taking the derivative we are calculating this derivative at $w = w_{MLE}$.

$$\frac{d^2}{dw^2} \ln L(w | n = 10, y = 7) = -\frac{7}{w^2} - \frac{3}{(1 - w)^2} = -47.62 < 0 \dots\dots\dots (2.11)$$

The second derivative value of log-likelihood function at $w = w_{MLE}$ show a negative value which sign that the MLE values which we get by equation 2.10 is the desired MLE.

It is not generally possible to find out an optimal solution of MLE estimation in practical, when the estimate model takes so many parameters and the PDF of this parameter are highly non-linear. At those cases MLE should use non-linear optimization algorithms. The basic idea

behind the use of non-linear optimization algorithms is that these algorithms are able to find-out a quickly solution to maximize the log-likelihood function [6], [7], [8].

2.5 Application of MLE

The Maximum likelihood estimation (MLE) used for a wide range of statistical models, including:

1. Linear models and generalized linear model
2. Discrete choice model
3. Many situation in the context of hypothesis testing and confidence interval formation
4. Exploratory and confirmatory factor analysis
5. Curve fitting
6. Structure equation modeling

These uses arise across applications in widespread set of fields, including:

1. communication systems
2. psychometrics
3. econometrics
4. time-delay of arrival (TDOA) in acoustic or electromagnetic detection
5. data modeling in nuclear and particle physics
6. magnetic resonance imaging
7. origin/destination and path-choice modeling in transport networks
8. Geographical satellite-image classification

CHAPTER 3

Channel Estimation for MIMO System

3.1 Introduction

To gain the knowledge about any MIMO wireless channel, the simplest method is to estimate the channel matrix of that MIMO System. This estimation includes the effect of no of antennas at transmitter or receiver side, antenna array system, carrier frequency, transmission path and many more others parameters. The obtained results from the estimation are dependent on channel capacity, correlation between the signal, path loss, and channel matrix order and on so many parameters. To improvement in channel capacity as well as to prevent the multipath delay effect we required the knowledge about the time varying channel. So, here our basic work is to find out the channel matrix and see the characteristics of channel matrix elements.

In our simulation work, our basic aim is to estimate the channel matrix for MIMO wireless communication by MLE techniques. We will develop a channel matrix for MIMO for a different pairs of transmitter-receiver system and afterwards estimate the channel matrix; we will extract the information from channel matrix.

3.2 Channel estimation in MIMO wireless environment using MLE Techniques:

Here we are estimating the MIMO channel matrix in wireless environment. In the maximum likelihood estimation techniques, we have to choose the fixed parameters that can maximize the likelihood function. So, first of all we have to fix the estimated parameters. Here we are assuming that the discrete receive signal which received at m th receive antenna from n th transmit antenna, where $f_n^{(k)}$ represent the k th sample of the code from n th transmit antenna represented as

$$y_m^{(k)} = \sum_{n=1}^{N_T} A_{mn} f_n^{(k)} \cos(\omega_0 + \phi^{(k)} + \phi_{mn}) + \eta_m^{(k)} \dots\dots\dots(3.1)$$

Where

ω_0 = Discrete carrier frequency which is recoverable

A_{mn} = Amplitude of transmitted signal from transmitter antenna n and received at receiver antenna m

ϕ_{mn} = Phase of transmitted signal from transmitter antenna n and received at receiver antenna m

k = number of samples

K = total number of channel matrix

$\phi^{(k)}$ = Carrier phase which is varying randomly

$f_n^{(k)}$ = k th sample of n th transmitter antenna code

$\eta_m^{(k)}$ = Discrete noise which we are assuming Gaussian amplitude distribution with zero-mean

N_T = Total number of transmitted antenna

N_R = Total number of received antenna

For the estimation we will use the amplitude and phase element as a parameter for MLE. We will make channel matrix from the amplitude and phase element for each transmitter-receiver combination. So the size of the channel matrix will be $N_T \times N_R$. We can accommodate the value of total number of transmitter and receiver antenna up to 16 but we will use two cases in our simulation. The first one is 4×4 (4 transmitter and 4 receiver) and another is 10×10 (10 transmitter and 10 receiver). So, in the very first beginning we can define the channel matrix as the channel matrix elements are dependent on amplitude and phase of the received signal. Now we can represent the channel matrix as

$$H_{mn} = A_{mn} e^{j\phi_{mn}} = H_{mn}^R + jH_{mn}^I$$

Here H_{mn}^R and H_{mn}^I are the real and imaginary part of channel transfer matrix. The channel matrix is complex channel matrix and its elements are complex fading coefficient.

Now we have to take a likelihood function which would be the function of our parameters and can gives likelihood of our data. Here we are considering a sequence of $k_2 - k_1 + 1$ sample which based on $K = k_2 - k_1 + 1$. This is the length of the code multiplied by the number of samples per symbol. The observed signal is $y_m^{(k)}$. So here we can represented the likelihood function as

$$T_m = \sum_{K=K_1}^{K_2} (y_m^{(k)} - U_{mk})^2 \dots\dots\dots(3.2)$$

Where
$$U_{mk} = \sum_{n=1}^{N_T} \{H_{mn}^R \cos(\omega_0 + \phi^{(k)}) - H_{mn}^I \sin(\omega_0 + \phi^{(k)})\} f_n^{(k)} \dots\dots\dots(3.3)$$

So the equation (3.2) can be represented as

$$T_m = \sum_{K=K1}^{K2} (y_m^{(k)} - \sum_{n=1}^{N_T} \{H_{mn}^R \cos(\omega_0 + \phi^{(k)}) - H_{mn}^I \sin(\omega_0 + \phi^{(k)})\} f_n^{(k)})^2 \dots\dots\dots(3.4)$$

According the MLE theory, to estimate the parameters we have to take the derivative of Likelihood function with respect to our parameters. So we are taking the derivative of T_m with respect to both H_{ms}^R and H_{ms}^I (real and imaginary part of channel matrix). Here, we are taking s as a variable with the range is in between 1 and N_T means $1 \leq s \leq N_T$.

After taking derivative and puts the result equal to zero. After solve all these mathematical operation we can directly write the results as

$$\sum_{K=K1}^{K2} y_m^{(k)} f_s^{(k)} \cos(\omega_0 + \phi^{(k)}) = \sum_{K=K1}^{K2} \sum_{n=1}^{N_T} f_n^{(k)} f_s^{(k)} \{H_{mn}^R (1 + \alpha_k) - H_{mn}^I \beta_k\} \dots\dots\dots(3.5)$$

$$\sum_{K=K1}^{K2} y_m^{(k)} f_s^{(k)} \sin(\omega_0 + \phi^{(k)}) = \sum_{K=K1}^{K2} \sum_{n=1}^{N_T} f_n^{(k)} f_s^{(k)} \{H_{mn}^I (1 - \alpha_k) - H_{mn}^R \beta_k\} \dots\dots\dots(3.6)$$

Where $1 \leq m \leq N_R$ and we are assuming $\cos[2(\omega_0 k + \phi^{(k)})]$ and $\sin[2(\omega_0 k + \phi^{(k)})]$ as α_k and β_k respectively for our mathematical convinces. Now we can form the equation (3.5) and equation (3.6) into matrix format.

$$\begin{bmatrix} D_m^R \\ D_m^I \end{bmatrix} = \begin{bmatrix} B_{11,m} & B_{12,m} \\ B_{21,m} & B_{22,m} \end{bmatrix} \begin{bmatrix} H_m^R \\ H_m^I \end{bmatrix} \dots\dots\dots(3.7)$$

From this matrix format of equations (3.5) and (3.6) we can find out the values of H_{mn}^R and H_{mn}^I for every single values of m . from the values of values of H_{mn}^R and H_{mn}^I we can written the channel matrix for one time sample as $H_{mn} = H_{mn}^R + jH_{mn}^I$. We have to calculate the channel matrix as the number of time samples are.

3.3 Analysis of Channel Matrix

3.3.1 Normalization of Channel Matrix

Since in the communication, actual receive power is not as same as we transmit from transmitted antenna, because the number of transmitter and receiver antennas, the noise present in the channel reflect the actual result. So it is become so compulsory that in between transmitters and receivers the power transfer must be unity. To be the power transfer between them unity normalization is required of channel transfer matrix H. Let $H_O^{(k)}$ and $H_N^{(k)}$ are the observed and normalize channel matrix respectively. Here we are taking normalization constant A. We have to measure A in such a way that $H_N^{(k)} = A H_O^{(k)}$, so the unity gain power constant may be expressed as

$$\sum_{k=1}^K \sum_{m=1}^M \sum_{n=1}^N \|A H_O^{(k)}\|^2 = 1 \dots \dots \dots (3.7)$$

Here, K= total number of channel matrix samples, after solving equation (3.7) for the normalization constant A is

$$A = \left(\frac{1}{KMN} \sum_{k=1}^K \sum_{m=1}^M \sum_{n=1}^N \|H_O^{(k)}\|^2 \right)^{(-0.5)} \dots \dots \dots (3.8)$$

After performing $H_N^{(k)} = A H_O^{(k)}$, we get the normalize channel transfer matrix.

3.3.2 Extraction of Channel information

From the normalization channel matrix which we estimate by the MLE, we are going to extract the channel information from channel matrix element. For extraction of channel information we have to analysis the characteristics of channel matrix element means characteristics of amplitude and phase one by one. The PDFs (probability density function) of the amplitude and phase of the channel matrix ‘H’ element can be estimated using the histograms functions of amplitude and phase respectively.

$$P_{mag}[x] = \frac{1}{KN_R N_T \Delta x} HIST(|H_{mn}^{(k)}|, \Delta x) \dots \dots \dots (3.9)$$

$$P_{pha}[x] = \frac{1}{KN_R N_T \Delta x} HIST(\angle H_{mn}^{(k)}, \Delta x) \dots \dots \dots (3.10)$$

Here, $HIST(f, \Delta x)$ = Histogram of the function ‘f’ where the size of bins is Δx

K = number of samples of channel transfer matrix

N_R = Total number of receive antennas at the receiver

N_T = Total number of transmit antennas at the transmitter

3.4 Simulation Result

Here, we are considering two cases for channel matrix characteristics. In the first case we take 4×4 data sets means we used 10 transmitter and receiver in simulation work. While in the second case we take 10×10 data sets in simulation work.

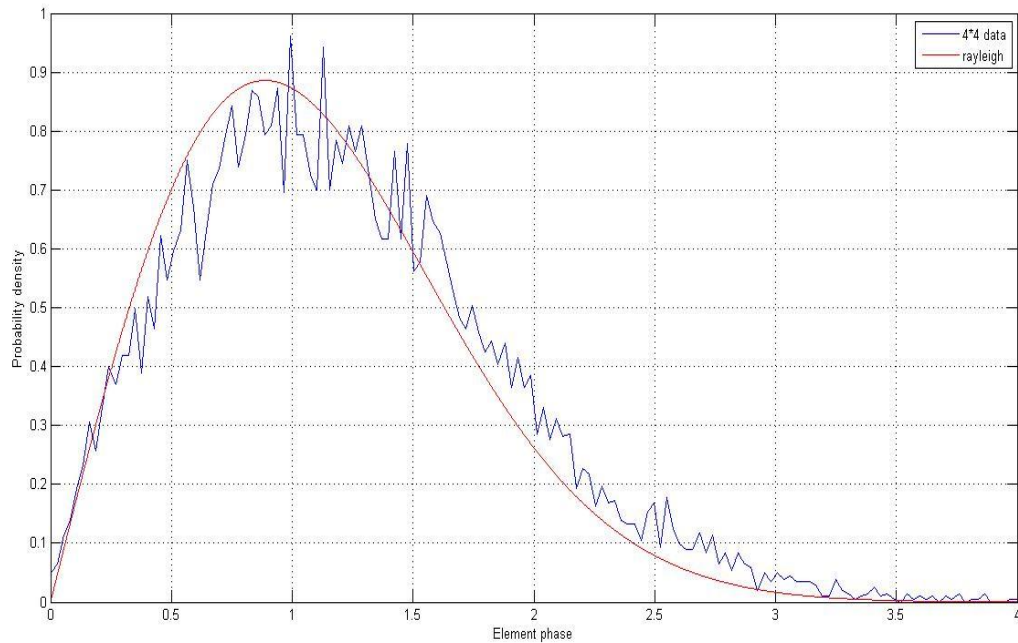

Fig. 5 Empirical PDFs for the magnitude of the 4×4 H matrix elements compared with Rayleigh PDF

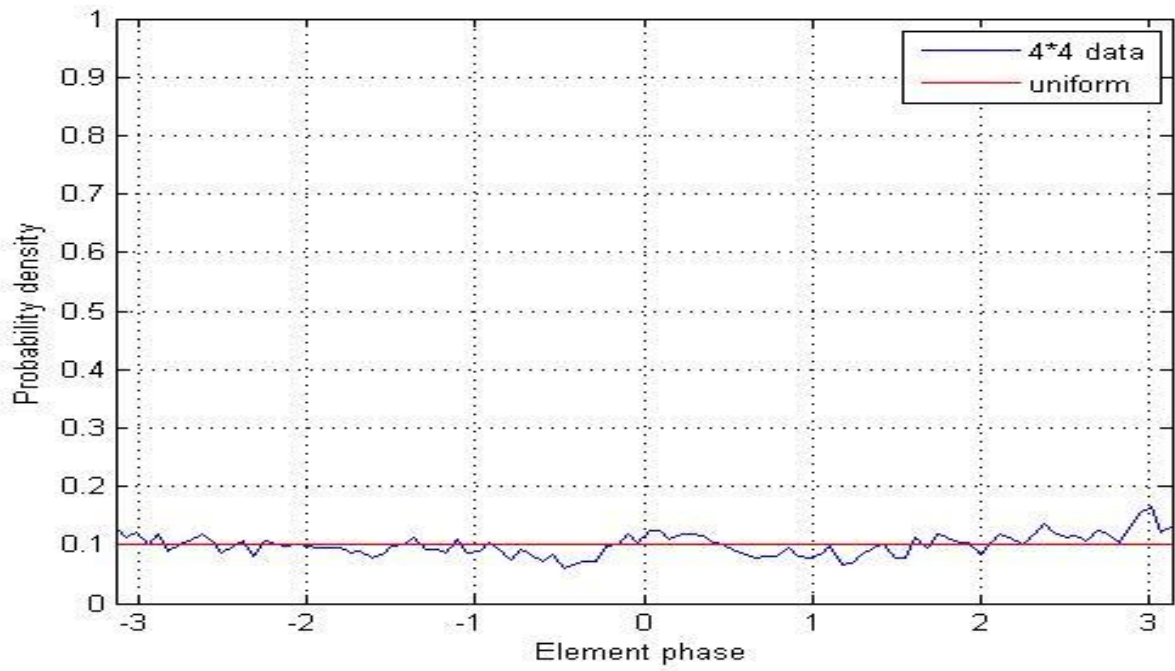

Fig. 6 Empirical PDFs for the magnitude of the 4×4 H matrix elements compared with Uniform PDF

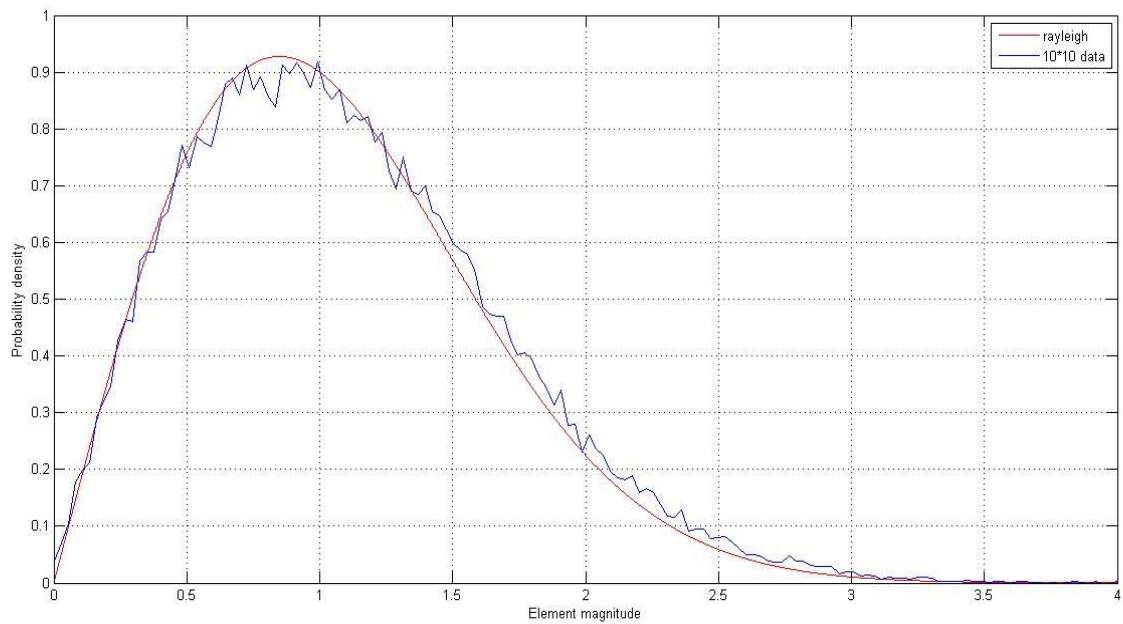

Fig. 7 Empirical PDFs for the magnitude of the 10×10 H matrix elements compared with Rayleigh PDF

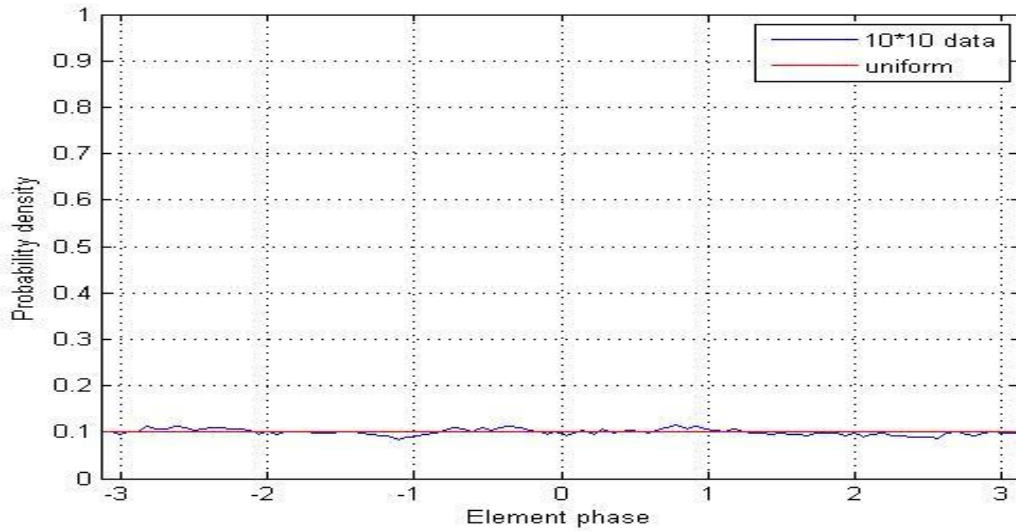

Fig. 8 Empirical PDFs for the magnitude of the 10×10 H matrix elements compared with Uniform PDF

The simulation results of channel matrix element (amplitude and phase) characteristics shown above. Figure 5 and 6 show the empirical PDFs for 4×4 data sets for magnitude and phase of respectively. While Figure 7 and 8 show the empirical PDFs for 10×10 data sets for magnitude and phase of respectively. These simulation results compared with Rayleigh distribution (for magnitude, parameter $\sigma^2 = 0.5$) and uniform distribution (for phase, parameter $\phi = [-\pi, \pi]$). When we compare the obtained result with Rayleigh and uniform parameter we can see that the arrangement between analytical and empirical PDFs is very good. When we increase the number of transmitter and receiver antennas elements the empirical PDFs show more fitness towards analytical PDFs. This shows the consistent property of MLE.

CHAPTER 4

Conclusion and Future work

4.1 Conclusion

In this work, we estimate the communication channel matrix in MIMO wireless environment. The basic understanding of MIMO system with its mathematical description is provided here. In this report brief overviews of various estimation techniques are explained. Here we use maximum likelihood as the estimation technique because, it provide consistent approaches to parameter estimation problem. At the end, the simulation results of estimated MIMO channel matrix parameters are provided. The result is compared with 10 transmitter and receiver antenna elements.

4.2 Future work

- Evaluate the response of the MIMO system by implementing different modulation schemes.
- Calculate the accuracy of the estimated channel by evaluating the bit error rate of the MIMO system.
- Measure the capacity of the MIMO system.

Bibliography

- [1] Steven Howard, Hakan Inanoglu, John Ketchurn “Result from MIMO Channel Measurement”, IEEE International Conference, 2002
- [2] Jerry R. Hampton, Manuel A. Cruz,” MIMO channel Measurement for urban military application”, IEEE International Conference, 2008
- [3] Jon W. Wallace, Member, IEEE, Michael A. Jensen, Senior Member,” Experiment Characterization of the MIMO wireless channel: Data acquisition and analysis” IEEE Transaction on Wireless communication, VOL. 2, NO. 2, MARCH 2003
- [4] C. Xiao, J.Wu, S.-Y. Leong, Y. R. Zheng, and K. B. Letaief, “A discrete-time model for spatial and temporal correlated MIMO WSSUS multipath channel” in Proc. 2003 IEEE Wireless Communication Network. Conference, vol. 1, New Orleans, LA, Mar. 16-20, 2003, pp. 354–358.
- [5] D.3. Shiu, G.J.Foschini, M.J. Gans, and J.M. Kahn, “Fading correlation and its effect on the capacity of multi-element antenna systems” IEEE Trans. Communication, *Mar.*2000.
- [6] Journal of Mathematical Psychology 47 (2003) 90–100 Tutorial on maximum likelihood estimation In Jae Myung Department of Psychology, Ohio State University, 1885 Neil Avenue Mall, Columbus, OH 43210-1222, USA Received 30 November 2001; revised 16 October 2002
- [7] Bickel, P. J., & Doksum, K. A. (1977).Mathematical statistics Oakland, CA: Holden-day, Inc.
- [8] DeGroot, M. H., & Schervish, M. J. (2002). Probability and statistics (3rd edition). Boston, MA: Addison-Wesley
- [9] Matthias Lieberei, Udo Zolzer, “MIMO Channel Measurements with Different Antennas in Different Environments” Department of Signal Processing and Communications, 2010 International ITG Workshop on Smart Antennas
- [10] C. Jandura, R. Fritzsche, G. P. Fettweis, and J. Voigt, “Analysis of MIMO Channel Measurements in Urban Areas”, IEEE International Conference, 2010
- [11] Jon W. Wallace, Michael A. Jensen and Ajay Gummalla, “Experimental Characterization of the Outdoor MIMO Wireless Channel Temporal Variation” IEEE Transaction on Vehicular Technology, May 2007

- [12] Barhumi, Imad, Geert Leus, and Marc Moonen. "Optimal training design for MIMO OFDM systems in mobile wireless channels." *Signal Processing, IEEE Transactions on* 51.6 (2003): 1615-1624.
- [13] Molisch, Andreas F., et al. "Capacity of MIMO systems based on measured wireless channels." *Selected Areas in Communications, IEEE Journal on* 20.3 (2002): 561-569.
- [14] Molisch, Andreas F., and Moe Z. Win. "MIMO systems with antenna selection", *Microwave Magazine, IEEE* 5.1 (2004): 46-56
- [15] Goldsmith, Andrea, et al. "Capacity limits of MIMO channels." *Selected Areas in Communications, IEEE Journal on* 21.5 (2003): 684-702.
- [16] Bölcskei, Helmut, ed. *Space-time wireless systems: from array processing to MIMO communications*. Cambridge University Press, 2006.
- [17] Wallace, Jon W., and Michael A. Jensen. "Modeling the indoor MIMO wireless channel." *Antennas and Propagation, IEEE Transactions on* 50.5 (2002): 591-599.
- [18] Kermaol, Jean Philippe, et al. "A stochastic MIMO radio channel model with experimental validation." *Selected Areas in Communications, IEEE Journal on* 20.6 (2002): 1211-1226.
- [19] Jensen, Michael A., and Jon W. Wallace. "A review of antennas and propagation for MIMO wireless communications." *Antennas and Propagation, IEEE Transactions on* 52.11 (2004): 2810-2824.
- [20] Baum, Daniel S., et al. "Measurement and characterization of broadband MIMO fixed wireless channels at 2.5 GHz." *Personal Wireless Communications, 2000 IEEE International Conference on*. IEEE, 2000.
- [21] Jensen, Michael A., and Jon W. Wallace. *MIMO wireless channel modeling and experimental characterization*. West Sussex, UK: Wiley, 2005.
- [22] D. Tse and P. Viswanath, *Fundamentals of Wireless Communication*, Cambridge University Press, 2005.
- [23] Kildal, P-S., and Kent Rosengren. "Correlation and capacity of MIMO systems and mutual coupling, radiation efficiency, and diversity gain of their antennas: simulations and measurements in a reverberation chamber." *Communications Magazine, IEEE* 42.12 (2004): 104-112