

# Optimized Design of Axially Symmetric Cassegrain Reflector antenna using Iterative Local Search Algorithm

A THESIS SUBMITTED IN PARTIAL FULFILLMENT  
OF THE REQUIREMENTS FOR THE DEGREE OF

**Master of Technology**  
In  
**Electronics Systems and Communication**

By

**OBULESU DANDU**  
**211EE1116**



**Department of Electrical Engineering**  
**National Institute of Technology, Rourkela**  
**Rourkela-769008**

# **Optimized Design of Axially Symmetric Cassegrain Reflector antenna using Iterative Local Search Algorithm**

A THESIS SUBMITTED IN PARTIAL FULFILLMENT  
OF THE REQUIREMENTS FOR THE DEGREE OF

**Master of Technology**  
In  
**Electronics Systems and Communication**

By

**OBULESU DANDU**  
**211EE1116**

Under the Guidance of

**Prof. K.R.SUBHASHINI**



**Department of Electrical Engineering**  
**National Institute of Technology, Rourkela**  
**Rourkela-769008**



**Department of Electrical Engineering  
National Institute of Technology Rourkela**

---

**CERTIFICATE**

This is to certify that the thesis entitled, “**Optimized Design of Axially Symmetric Cassegrain Reflector Antenna using Iterative Local Search Algorithm**” submitted by **Mr. Obulesu Dandu** in partial fulfillment of the requirements for the award of Master of Technology Degree in electrical Engineering with specialization in “**Electronics Systems and Communication**” during session 2011-13 at the National Institute of Technology, Rourkela (Deemed University) is an authentic work carried out by him under my supervision and guidance.

To the best of my knowledge, the matter embodied in the thesis has not been submitted to any other University/ Institute for the award of any degree or diploma.

*Date:*

**Prof. K.R.Subhashini**

Department of Electrical Engineering  
National Institute of Technology  
Rourkela-769008

## ACKNOWLEDGEMENTS

This project is by far the most significant accomplishment in my life and it would be impossible without people who supported me and believed in me.

I would like to extend my gratitude and my sincere thanks to my supervisor **Prof. K.R.Subhashini**, Department of Electrical Engineering. I express my gratitude to faculties Professors P.K.SAHOO, D. PATRA , S.DAS for their advices during inter evaluation.

I am very much thankful to our Head of the Department, **Prof. A.K.Panda**, for providing us with best facilities in the department and his timely suggestions. I am very much thankful for providing valuable suggestions during my thesis work to all my teachers in the Department. They have been great sources of inspiration to me and I thank them from the bottom of my heart.

I would like to thank DONDAPATI.SUNEEL VARMA, BANDARU SRINIVASA RAO and K.VENKATESWARA RAO for their support and suggestions during problem solving.

I would like to thank all my friends and especially my classmates for all the thoughtful and mind stimulating discussions we had, which prompted us to think beyond the obvious. I've enjoyed their companionship so much during my stay at NIT, Rourkela.

I would like to thank all those who made my stay in Rourkela an unforgettable and rewarding experience.

Last but not least I would like to thank my parents, who taught me the value of hard work by their own example. They rendered me enormous support being apart during the whole tenure of my stay in NIT Rourkela.

**Obulesu Dandu**

# TABLE OF CONTENT

1	INTRODUCTION AND SCOPE OF THE PROJECT	1
	1.1 Objective	2
	1.2 Motivation	2
	1.3 Introduction	3
	1.4 Specifications of 18.5 GHz Reflector Antenna	4
	1.5 Aim of the project	4
	1.6 Organization of Thesis	5
2	CASSEGRAIN ANTENNA CONFIGURATION	6
	2.1 Introduction	7
	2.1.1 Advantages	7
	2.2 Cassegrain Antenna Design	8
	2.2.1 Cassegrain Antenna Design Parameters	8
	2.3 Parabolic Reflector	9
	2.4 Parabolic Reflector Design	10
	2.4.1 Geometry	10
	2.4.2 f/D Ratio	11
	2.4.3 Electrical and Mechanical considerations for f/D Ratio	12
	2.5 Dish Illumination	13
	2.6 Advantages of Parabolic Reflectors	13
	2.7 Shroud	13
	2.8 Cassegrain Sub Reflector	14
	2.9 Feed Horn Design	16
	2.9.1 Waveguide Horn	16
	2.10 Radome	19
	2.11 18.5 GHz Main Reflector Design Values	20
	2.12 Main Reflector Contour Co-ordinates	21
	2.13 18 GHz Cassegrain Sub Reflector Design	21
	2.14 Sub Reflector Contour Co-ordinates	23
	2.15 Summary	23

3	ITERATIVE LOCAL SEARCH ALGORITHM	24
	3.1 Iterated Local Search algorithm	25
	3.1.1 Strategy	25
	3.1.2 Pseudo code for Iterated Local Search.	25
	3.1.3 Heuristics	26
4.	ANALYSIS OF CASSEGRAIN ANTENNA USING GRASP SOFTWARE	27
	4.1 Introduction	28
	4.2 Dual Reflector Blockage	29
	4.3 Subreflector Blockage	30
	4.4 Visualizing the Geometry	30
	4.4.1 Visualizing the geometry as an open loop GL plot	31
	4.4.2 Visualizing the geometry as an open loop Object plot	31
	4.4.3 Radiation Pattern	32
	4.5 Summary	36
	4.6 Aluminum alloys-Advantages	36
	4.7 RF Absorber -Advantages	37
5	RESULTS	38-43
6	CONCLUSION AND FUTURE WORK	44
	6.1 Conclusions	45
	6.2 Future Scope of the Project	45
	REFERENCES	46-47

## LIST OF FIGURES

2.1	2-D CAD view of Cassegrain Antenna	8
2.2	Cassegrain Antenna Edge Taper	12
2.3	CAD Parabolic Reflector Contour	13
2.4	Optimum Cassegrain subreflector size	15
4.1	Open GL plot	31
4.2	Radiation pattern at a frequency 17.3 GHz	32
4.3	Radiation pattern at a frequency 18 GHz	33
4.4	Radiation pattern at a frequency 18.5 GHz	34
4.5	Radiation pattern at a frequency 19 GHz	35
4.6	Radiation pattern at a frequency 19.5 GHz	35
5.1	Gain vs. Number of iterations by using Iterative Local Search Algorithm	39
5.2	3-D View of the Cassegrain Reflector Antenna	39
5.3	E-field Radiation pattern at frequency 18.5 GHz with constant $\theta = 0^\circ$	40
5.4	E-field cross polarization at frequency 18.5 GHz with constant $\theta = 45^\circ$	40
5.5	Far field ' $\theta$ ' constant magnitude cuts using ICARA	41
5.6	Near field ' $\theta$ ' constant magnitude cuts using ICARA	41
5.7	Co- polar magnitude plot	42
5.8	Co-polar phase plot	42
5.9	Far field cross polarization phase plot	43
5.10	Far field co-polarization magnitude contours	43

## LIST OF TABLES

2.1	Main Reflector Contour Co-ordinates	21
2.2	Sub Reflector Contour Co-ordinates	23
4.1	Tabular form of radiation values at a frequency 17.3 GHz.	33
4.2	Tabular form of radiation values at a frequency 18 GHz.	33
4.3	Tabular form of radiation values at a frequency 18.5 GHz.	34
4.4	Tabular form of radiation values at a frequency 19 GHz.	35
4.5	Tabular form of radiation values at a frequency 19.7 GHz.	36
4.6	Tabular Form of beam width and gains with varying frequencies	36



**CHAPTER 1**

**INTRODUCTION**  
**AND**  
**SCOPE OF THE PROJECT**

## 1.1 Objective

Dual reflector antennas are considered as pencil beam antennas that can produce radiation identical to searchlight beams. As compared with front-fed configuration, design of dual-reflector geometry is complicated since the parameters like feed location, sub reflector size, required taper on sub reflector, selection of focal length to diameter ratio of the main reflector, amplitude distribution provided by feed etc. are to be adjusted as per the given specifications. Also the side lobe suppression effort requires the antenna to be designed for minimum sub reflector blockage. The design of such a cassegrain reflector is considered for the minimum blockage condition. Along with the parameters like high gain and low cross-polarization; low VSWR is also one of the prenominal parameter that can be achieved. The optimized values of  $\frac{f}{D}$  and angle subtended by the sub reflector is obtained by using Iterative Local Search algorithm. For obtaining the radiation diagrams, 'Induced Current Analysis of Reflector Antenna' and GRASP soft wares are used. This will help us to identify the factors that affect the radiation pattern of the antenna.

## 1.2 Motivation

During the 1980s the need became greater for a lower profile microwave antenna that also exhibited superior pattern performance. Two forces drove this requirement. One was the need to reduce the visual impact of radio communication installations. The other was the need to place more and more microwave links in the same geographic area. Large aperture antennas can be built with reflectors or arrays but reflectors are far simpler than arrays. Array needs an elaborate network but reflector uses simple feed and free space. At microwave frequencies the physical size of a high gain antenna becomes small enough to make the practical use of suitably shaped reflectors to produce the desired directivity. Here reflectors are curved surfaces. Although wire or rod antennas can be and are used either singly or in arrays at UHF and SHF but other types utilizing reflecting or radiating surfaces are generally more practical and hence used extensively. As the frequency increases, the wavelength decreases and thus it becomes easier to construct an antenna system that are large in terms of wavelengths and which therefore can be made to have greater directivity.

Parabolic reflectors are based on the geometric optical principles. Their feed methods are also not by coaxial cable but by optical methods. Reflector antennas in one form or another have been in use since the discovery of electromagnetic wave propagation in 1888 by Hertz. The spectacular progress in the development of sophisticated analytical and experimental techniques in shaping the reflector surfaces and optimizing illumination over their apertures so as

to maximize the gain lead to vital applications resulting in establishing the reflector antenna almost as a household word during the 1960s.

### **1.3 Introduction**

The first comprehensive published analysis of the Cassegrain arrangement as a microwave antenna was done by Hannan. To improve the performance of large ground based microwave reflector antennas for satellite tracking and communication, Cassegrain has proposed a two reflector system. Initial design & experimentation with microwave antennas began more than 100 years ago, reaching back to that key pioneer of well-known fame, Guglielmo Marconi. Microwave system work using parabolic antennas grew significantly during the 1930s. During World War II designs such as pencil beam and shaped beam antennas were developed for radar systems used by Allies. While many advances were made at this time, it was in the 1950s that terrestrial microwave communication systems were deployed and parabolic reflector designs were utilized on these commercial systems. Over time, numerous feed designs have been developed, some more optimum than others.

To achieve the desired collimation characteristics, the larger (Main) reflector must be a paraboloid and the smaller (secondary) a hyperboloid. Cassegrain antennas are widely used in today's world of millimeter wave communications. Due to the high gain and pencil-sharp beam width they are mostly used for point-to-point links and mesh network terminals, but also works well for radar and satellite communication applications. The fact of Cassegrain antennas popularity is based on a general rule, that if the diameter of the main reflector is greater than ten wavelengths, the Cassegrain system is a contending option compare to other antenna types.

Cassegrain antenna is a double reflector system which works on the principle of Cassegrain optical telescope. The initial design was invented in 1672 by the French astronomer Laurent Cassegrain who was working on improvement of classic Newton telescope.

. The advantage of cassegrain sub reflector is that it reduces spillover and beam can be broadened by adjusting one of the reflector surfaces The Cassegrain design employs a parabolic contour for the main dish and a hyperbolic contour for the sub dish. One of the two focuses of the hyperbola is the real focal points of the system and is located at the center of the feed; the other is a virtual focal point which is located at the focus of the parabola. The main advantages of Cassegrain antenna are a reduction in the axial dimensions of the antenna just as in optics and a greater flexibility in the design of the feed system. To achieve good radiation characteristics, the

sub reflector or sub dish must be a several, at least a few wavelengths in diameter and usually it is ten times the main reflector size in wavelengths.

## **1.4 Specifications of 18.5 GHz Reflector Antenna**

### **1.4.1 General**

Antenna Type : High performance, low profile Cassegrain Reflector  
Diameter : 635 mm  
Polarization : Single Linear  
Operative Frequency Range : (17.3 -19.7) GHz

### **1.4.2 Electrical**

**RPE**(Radiation Pattern Envelope) : Class 2, **ETSI** (European Telecommunications Standards Institute)  
Minimum Gain : 38 dBi  
Maximum **XPD** (Cross Polarization Discrimination) : 30 dB  
Maximum VSWR (Voltage Standing Wave Ratio) : 1.3 : 1  
Front to Back Ratio : 58 dB

## **1.5 Aim of the project**

The aim of the project is to “**Optimized Design of Axially Symmetric Cassegrain Reflector Antenna using Iterative Local Search Algorithm**”

A reflector antenna with a Cassegrain sub reflector can be used to obtain high gains. In many professional applications this can be used for satellite as well as for astronomy, microwave data links and other new emerging modes of personal and business communications. It is often being seen on radio relay towers and mobile phone antenna masts.

## **1.6 Organization of Thesis**

The following paragraphs summarize the content of each chapter.

- Chapter-1** Gives an introduction and aim of the project
- Chapter-2** Highlights the basic nature of Cassegrain Reflector antenna theory and gives the step by step design approach.
- Chapter-3** Gives the optimized values of variables using Iterative Local Search.
- Chapter-4** Analysis of Cassegrain Antenna using GRASP software.
- Chapter-5** Results.
- Chapter-6** Gives the conclusion and the future scope of the project

**CHAPTER 2**  
**CASSEGRAIN ANTENNA**  
**CONFIGURATION**

## **2.1 Introduction**

A typical parabolic antenna consists of a parabolic reflector with a small feed antenna at its focus. The reflector is a metallic surface formed into a paraboloid of revolution and (usually) truncated in a circular rim that forms the diameter of the antenna. This paraboloid possesses a distinct focal point by virtue of having the reflective property of parabolas in that a point light source at this focus produces a parallel light beam aligned with the axis of revolution. The feed antenna at the reflector's focus is typically a low gain type such as a small waveguide horn. In more complex designs, such as the cassegrain antenna, a sub-reflector is used to direct the energy into the parabolic reflector from a feed antenna located away from the primary focal point. The feed antenna is connected to the associated radio-frequency (RF) transmitting or receiving equipment by means of coaxial cable transmission line or hollow waveguide. Sometimes it becomes important to minimize the length of transmission line or waveguide connecting the feed radiator with receiver or transmitter. This is needed specially to avoid losses. Although there could be a solution of this problem by placing RF amplifier stage of receiver near the focus which minimizes the losses on reception. But this is not practicable for transmission, as the RF amplifier of a transmitter is bulky, heavy and having enough power so it is not possible to place at feed point. Hence the practical solution in such case is cassegrain configuration when the transmission line or waveguide length between feed and transmitter and receiver is required to be short.

### **2.1.1 Advantages**

- Spillover and minor lobe radiation is less.
- It is possible to scan the beam or to broaden the beam by moving the reflecting surfaces.
- High gain can be achieved

## 2.2 Cassegrain Antenna Design

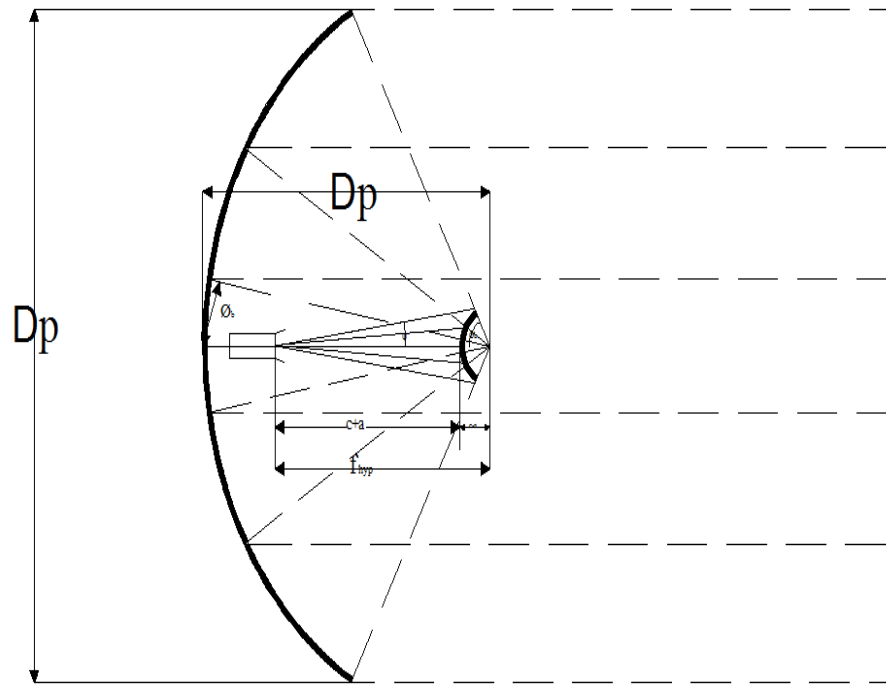

Figure 2.1: 2-D CAD view of Cassegrain Antenna

### 2.2.1 Cassegrain Antenna Design Parameters

$D_p$  = Parabolic dish diameter

$f_p$  = Parabolic dish focal length

$d_{sub}$  = Sub reflector diameter

$f_{hyp}$  = focal length of hyperbola – between foci

$a$  = parameter of hyperbola

$c = \frac{f_{hyp}}{2}$  = parameter of hyperbola

$\theta_0$  = angle subtended by parabola

$\psi$  = angle subtended by sub reflector

$\theta_b$  = angle blocked by sub reflector

$\alpha$  = angle blocked by feed horn



## 2.3 Parabolic Reflector

A Parabola is a two dimensional plane wave. A practical reflector is a three dimensional curved surface. Therefore, a practical reflector is formed by rotating a parabola about its axis. The surface so generated is known as PARABOLOID which is often called as “MICROWAVE DISH” or “PARABOLIC REFLECTOR”.

Parabolic produces a parallel beam of circular cross section because the mouth of the parabola is circular. If a third Cartesian co-ordinate z has its axis perpendicular to both X axis and Y axis.

$$y^2 + z^2 = 4fx \dots\dots\dots (2.3.1)$$

Narrow major beam is in the direction of paraboloid axis. If the feed or primary antenna is isotropic then the paraboloid will produce a beam of radiation. Assuming circular aperture is large, the BWFN (Beam Width between First Nulls)

$$BWFN = \frac{140\lambda}{D} \dots\dots\dots (2.3.2)$$

Where

$\lambda$ = free space wavelength in meters.

D= Diameter of aperture in meters.

For rectangular aperture,

$$BWFN = \frac{115\lambda}{L} \dots\dots\dots (2.3.3)$$

Where L = Length of aperture ( $\lambda$ )

Width between half power points for a large circular aperture is given by

$$HPBW = \frac{58\lambda}{D} \dots\dots\dots (2.3.4)$$

Further the directivity D of a large uniform illuminated aperture,

$$D = \frac{4\pi A}{\lambda^2} \dots\dots\dots (2.3.5)$$

For circular aperture

$$D = \frac{4\pi A}{\lambda^2} \dots\dots\dots (2.3.6)$$

$$D = 9.87 \left(\frac{D}{\lambda}\right)^2 \dots\dots\dots (2.3.7)$$

In practice, the primary (or feed) antenna is not isotropic and thus does not radiate uniformly which introduces distortion. Besides, the surface of paraboloid is not uniformly illuminated as there is gradual tapering towards the edge. This results in less capture area which is smaller than the actual area i.e.,

$$A_0 = kA \quad \dots\dots\dots (2.3.8)$$

Where

$A_0$  = Capture area

$A$  =Actual area of mouth

$k$  = Constant depends on type of antenna used for feed =0.65(for dipole antenna)

Effective radiated power (ERP) = Input power fed to antenna x power gain

$$G_p = 6 \left(\frac{D}{\lambda}\right)^2 \quad \dots\dots\dots (2.3.9)$$

If actual power fed to a parabolic reflector is 1W then ERP will be 9600 W.

With the help of paraboloid reflector, extremely large gain and narrow beam widths can be achieved. For effective and useful use, a paraboloid reflector must have an open circular mouth aperture of minimum  $10 \lambda$ . At very low frequency, mouth is large, heavy and bulky, hence avoided at TV broadcast band.

## 2.4 Parabolic Reflector Design

### 2.4.1 Geometry

The basic property of paraboloid reflector is that it converts a spherical wave irradiating from a point source places at the focus into a plane wave. Conversely, all the energy received by the dish from a distant source is reflected to a single point at the focus of the dish. The position of the focus or focal length is given by

$$f = \frac{D^2}{16d} \quad \dots\dots\dots (2.4.1)$$

### 2.4.2 f/D Ratio

Paraboloid reflector can be designed by keeping the mouth diameter fixed and varying the focal length(f) also .In designing a reflector antenna , the antenna needs to properly illuminate the reflector i.e., the beam width of the antenna needs to match the f/D ratio of the parabolic reflector. Otherwise the antenna of an over illuminated reflector would receive a noise from behind the parabolic reflector. Likewise, an under illuminated reflector does not use its total surface area to focus a signal on its antenna.

Size of the dish is the most important factor since it determines the maximum gain that can be achieved at the given frequency and the resulting beam width.

$$\text{Gain } G = \left(\frac{\pi D}{\lambda}\right)^2 * \eta \dots\dots\dots (2.4.2)$$

Efficiency is determined mainly by the effectiveness of illumination of the dish by the feed. Each time the diameter of a dish is doubled the gain is four times or 6 dB greater. The lower the f/d ratio, the lower the side lobes because the feed is more protected from stray rays. Side lobes can also be reduced by means of additional shielding on the rim of the parabolic reflector.

$$\text{Half subtended angle of the main reflector } \phi = 2 \tan^{-1} \left( \frac{1}{4 \left( \frac{f}{D_p} \right)} \right) \dots\dots\dots (2.4.3)$$

$$\text{Effective focal length of the main reflector } f_e = \frac{D}{4 \tan \left( \frac{\psi}{2} \right)} \dots\dots\dots (2.4.4)$$

$$\text{Space attenuation of the main reflector } (S.A)_{Main} = 20 \log \left( \frac{2}{1 + \cos(\phi)} \right) \dots\dots\dots (2.4.5)$$

Optimum value of the illumination taper is given by the graph or formula

$$taper = 0.72(\log D_p)^2 - 4.16(\log D_p) + 17.7 \text{ When } D_p < 500\lambda \dots (2.4.6)$$

Milligan includes approximations for the losses in smaller dishes, based on the work of Kidal. Diffraction is a major contributor to losses in small dishes. Kidal found that the illumination edge taper in a Cassegrain antennas should be greater than the nominal 10 dB edge taper for prime focus dish, to reduce diffraction loss. Since diffraction occurs near the edge of a reflector, reducing the edge illumination should reduce the diffracted energy, while the illumination loss increases slightly. The plot which gives the relation between optimum illumination taper vs. dish diameter is

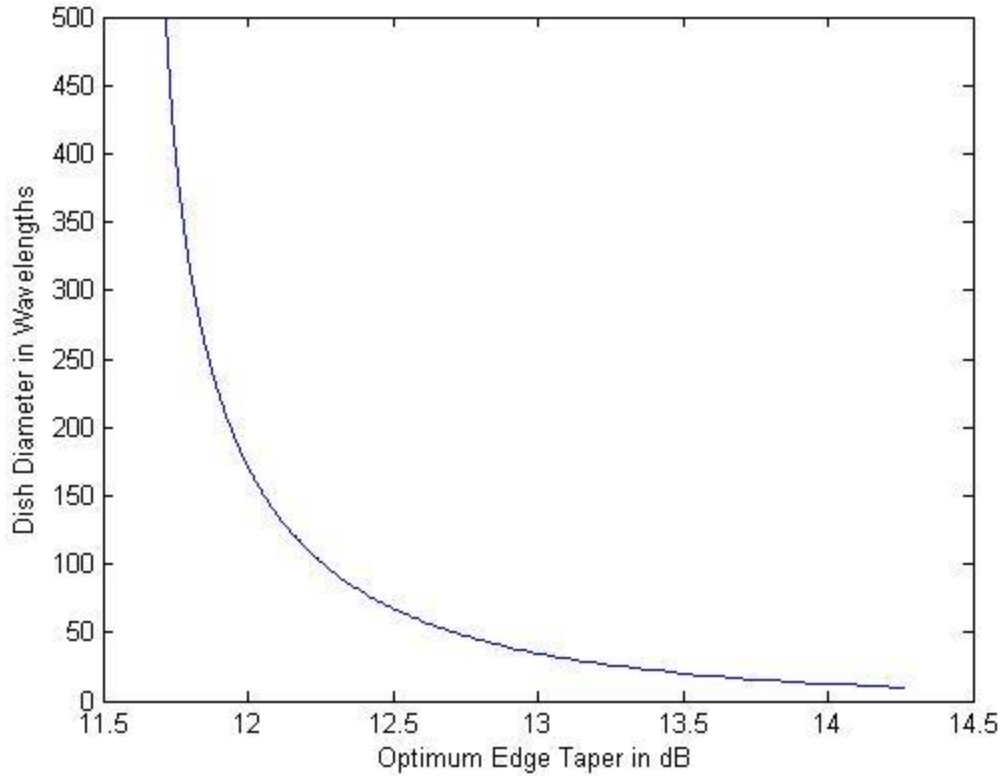

Figure 2.2: Cassegrain Antenna Edge Taper

Adjusted illumination taper of the feed w.r.t. sub reflector to get the desired taper is

$$\psi^1 = \psi \sqrt{\left(\frac{\text{taper in dB} - S.A_{Dish}}{10 - S.A_{Sub}}\right)} \dots\dots\dots (2.4.7)$$

Adjusted effective focal length  $f_e^1 = \frac{D_p}{4 \tan\left(\frac{\psi^1}{2}\right)} \dots\dots\dots (2.4.8)$

**2.4.3 Electrical and Mechanical considerations for f/D Ratio**

- Small f/D ratio for deep-dish reflectors
- Large f/D ratio for shallow dish reflectors
- Shallow dishes are easier to support and move mechanically
- Feed has to be farther from reflector
- Farther feed results in narrow primary pattern
- Feed has to be larger also
- f/D ranges from 0.3-0.5 in general and 0.5 -1.0 for mono-pulse tracking radar antennas

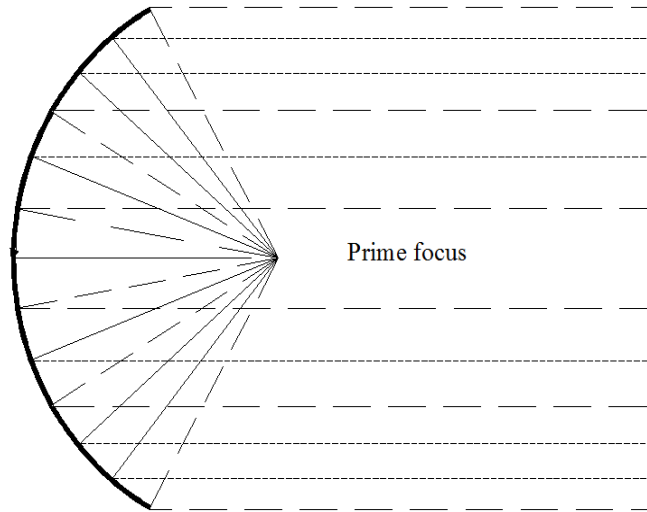

Figure 2.3: CAD view of Parabolic Reflector Contour

## 2.5 Dish Illumination

Illuminate as much as the reflecting surface as possible as well as avoiding spillover. Best results are obtained with a tapered illumination that will progressively diminish the illumination of the edges thus reducing side lobes and spillover. Two dishes of the same diameter but different focal lengths require different designs of feed if both are illuminated efficiently.

## 2.6 Advantages of Parabolic Reflectors

- Parabolic reflectors can provide high gain.
- Ease of fabrication in quantities.
- Small gain antennas can be used as feed to obtain high gain.
- Complete transceiver can be located at the focus of a very cost effective long distance communication system.

## 2.7 Shroud

Shrouds are added to parabolic microwave antennas to reduce the side lobe level being radiated to reduce the side lobe level being radiated. They appear to look like drums or a tunnel that has a diameter about the same as the parabolic reflector and is bolted on the surface. The shroud is also lined with flat absorber material to enhance pattern performance.

## 2.8 Cassegrain SubReflector

The Cassegrain antenna adds a hyperbolic subreflector, acting as a mirror to reflect the feed position back toward the main reflector. . To minimize loss from diffraction and spillover, the subreflector should be electrically large, greater than 10 wavelengths in diameter, or about 1 foot at 10 GHz. The subreflector diameter should be less than 20% of the dish diameter to minimize blockage by the subreflector, so the dish should be larger than 50 wavelengths diameter. Antenna efficiency decreasing rapidly for subreflectors smaller than ten wavelengths and for diameter ratios greater than 0.1. For very deep dishes where available feeds can only provide poor efficiency, a Cassegrain system with a good feed horn might achieve better overall efficiency. At the higher microwave frequencies, feed line loss can be high enough to significantly reduce overall efficiency, so the more accessible feed location of the Cassegrain system is a good alternative.

Hyperbola dimensions for the subreflector are necessary to reshape the feed horn pattern to properly illuminate the dish, as well as the desired hyperbola focal length, the distance between the two foci of the hyperbola. One focus of the hyperbola is at the focal point of the dish which is called as the virtual focus. No RF ever reaches it, but the RF from the feed reflected by the subreflector appears to originate from the virtual focus. The feed horn phase center is at the other focus of the hyperbola. The feed horn illuminates the sub reflector, which subtends the angle  $\Psi$ . Diffraction is a major contribution to losses in small dishes. Diffraction occurs near the edge of a reflector, reducing the edge illumination should reduce the diffracted energy. The optimum sub reflector size to minimize the combination of blockage and diffraction losses is given by

$$\left(\frac{d_{sub}}{D_p}\right) = \left[ \frac{\cos^4\left(\frac{\psi^1}{2}\right) E \lambda}{(4\pi)^2 \sin\phi D_p} \right]^{1/5} \dots\dots\dots (2.8.1)$$

Where E is the edge taper

$$E = 10^{(-taper \text{ in dB}/10)}$$

The optimum value of d/D, the ratio of subreflector diameter to dish diameter, for any size dish and edge taper is given by the plot

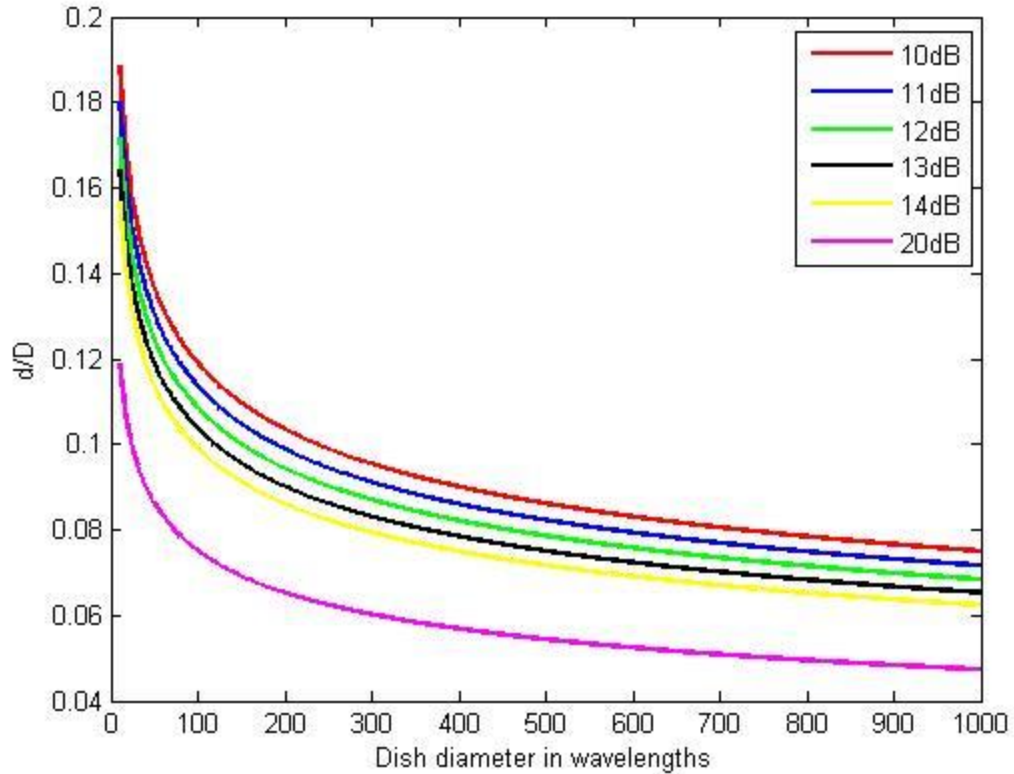

Figure 2.4: Optimum Cassegrain Subreflector size

Approximate efficiency for the combination of blockage and diffraction losses,

$$\eta_{sub} = \left[ 1 - C_b \left( 1 + 4 \left( 1 - \left( \frac{d_{sub}}{D} \right)^{1/2} \right) \left( \frac{d_{sub}}{D} \right) \right) \right]^2 \dots\dots\dots (2.8.2)$$

Where  $C_b = \frac{-\ln\sqrt{(E)}}{1-\sqrt{(E)}}$

A feed horn with a wide beam would be closer to the sub reflector than a feed horn with a narrow beam .The f/D for maximum efficiency is the dish best illuminated by that feed. The total edge taper is the sum of the feed taper, radiation pattern of the feed at the edge of the dish, and the space attenuation. For example, a dish with an f/D of 0.35 has 3.6 dB of space attenuation and an illumination angle of 142 ° .To provide an edge taper of 10 dB, a feed must have a pattern that is 6.4 dB down at the edge, 90° from the axis, so that the sum of the pattern and the 3.6 dB space attenuation is 10 dB Since the feed pattern is only 6.4 dB down at the edge, some spillover is inevitable.

## 2.9 Feed Horn Design

A feed is the main point of contact between the dish and the coaxial cable or a waveguide. In short feed is a medium of communication for the dish i.e., waves are transmitted and received with the help of the dish. Horn is an impedance transformer, gradually transitioning from the constrained impedance of a waveguide to the impedance of free space. A horn antenna is a useful and simple radiator excited by waveguide. If the waveguide size is slowly expanded or tapered then more gain can be achieved preventing undesired modes from reaching the waveguide. Horn antenna is used as focal point feed in many reflector antennas. The losses in the horn are negligible. The function of the horn is to produce a uniform phase front with a larger aperture than that of the guide and hence greater directivity.

### 2.9.1 Waveguide Horn

- More Directivity
- Acts as point source with large reflectors
- For uniform radiation pattern across parabolic aperture only a small angular portion of the pattern should be used
- The ratio of  $f/D$  should be large for uniform illumination
- A part of energy radiated by the feed and not intercepted by the paraboloid amounts to loss. This loss or spillover results in lowering the overall efficiency and defeats the purpose of uniform illumination.
- If the ratio  $f/D$  is increased further, spillover is less, intercepted energy and thus efficiency increases. But since illumination is more tapered the aperture efficiency decreases.

Corrugated horn was described by Simmons and Kay and it is called as Scalar Feed. The aperture diameter plus the length completely defines the horn. Corrugated horns exhibit a combination of highly desirable characteristics such as high beam symmetry, low cross polarization, low level of side lobes, good return loss and low attenuation.

The idea is to eliminate the E plane edge currents in the rim of the horn by adding slots or grooves perpendicular to the length of the horn. The grooves are made deep enough so that the surface reactance is capacitive, surface waves cannot be supported. The required depth is greater than  $\lambda/4$ .

Conical horns are simpler. The aperture diameter is chosen analytically to give the desired co-planar pattern beam width. For the linear design, the diameter has been evaluated by means of



simulations carried out by calculating the radiation pattern under the pure HE<sub>11</sub> mode propagation in circular waveguide with a phase distribution given by a spherical phase front with center in the apex of the horn. Since the depth and shape of corrugations determine the cross-polarization radiation characteristic, their geometry was selected to give the minimum level of cross-polarization at the center frequency.

The corrugations are about a quarter wavelengths deep and there are at least three corrugations per wavelength in order to well approximate a continuous impedance surface. The junction and throat region were designed to optimize the impedance match to the smooth wall waveguide. For this purpose the first slot seen but the smooth wall waveguide is approximately half a wavelength deep with the following few slots (about 5) constituting a transition region to the quarter wavelength steady state depth of the remaining part.. Also the teeth and groove length need to be varied continuously between the first corrugations and the steady state region; a good input matching require thick teeth and thin grooves which are used at the beginning, while on the contrary , HE<sub>11</sub> propagation is well supported by thick grooves and thin teeth.

One focus of the hyperbola is at the focal point of the dish; which is referred to as virtual focus. No RF ever reaches it, but the RF from the feed reflected by the sub reflector appears to originate from the virtual focus. The feed horn phase center is at the other focus of the hyperbola.

The feed horn illuminates the sub reflector, which subtends the angle  $\psi$ . A feed horn with a wide beam would be closer to the sub reflector than a feed horn with a narrow beam.

The subtended half-angle to illuminate a given  $f/D$  is

$$\psi = 2 \operatorname{Tan}^{-1} \left( \frac{1}{4 \left( \frac{f}{D} \right)} \right) \dots\dots\dots (2.9.1)$$

To adjust this for the edge taper, we use Kelleher's universal horn equation to correct the illumination angle for the desired edge taper.

$$\psi^1 = \psi \sqrt{\left( \frac{\text{taper in dB}}{10} \right)} \dots\dots\dots (2.9.2)$$

The adjusted illumination angle for desired taper can be calculated from feed horn

$$\psi^1 = \psi \sqrt{\left( \frac{\text{taper in dB} - S.A_{Dish}}{10 - S.A_{Sub}} \right)} \dots\dots\dots (2.9.3)$$

The feed must be positioned such that the angle subtended by the sub reflector is  $\psi^1$ , placing the feed at one focus of the hyperbola and the dish prime focus at the other as shown in Fig 2.1.

Thus, the hyperbola focal length, the distance between the two foci is

$$f_{hyp} = 0.5d_{sub}(cot(\psi^1) + cot(\psi)) \dots\dots\dots (2.9.4)$$

Rays near the center of the beam that reflect from the sub reflector at angles less than  $\varphi_b$  are eventually blocked by the sub reflector. If  $\alpha > \varphi_b$  then the angle shadowed by the feed horn is larger than the angle shadowed by the sub reflector, so the feed will cause additional blockage loss.

$$\varphi_b = \sin^{-1}\left(\frac{d_{sub}}{2f_p}\right) \dots\dots\dots (2.9.5)$$

$$\alpha = \tan^{-1}\left(\frac{d_{feed}}{2f_{hyp}}\right) \dots\dots\dots (2.9.6)$$

The effective  $f/D$  for the feed is given by

$$Effective\ Feed\ f/D = \frac{1}{4\tan(\frac{\psi}{2})} \dots\dots\dots (2.9.7)$$

The sub reflector must reshape the illumination from the effective feed  $\frac{f}{D}$  to  $\frac{f_p}{D_p}$  for the dish

The magnification factor is given by

$$M = \frac{Effective\ Feed\ (\frac{f}{D})}{(\frac{f_p}{D_p})} \dots\dots\dots (2.9.8)$$

The amount of curvature is called Eccentricity,

$$Eccentricity\ e = \frac{M+1}{M-1} \dots\dots\dots (2.9.9)$$

Hyperbola parameters can be calculated as

$$c = \frac{f_{hyp}}{2} \dots\dots\dots (2.9.10)$$

$$a = \frac{c}{e} \dots\dots\dots (2.9.11)$$

$$b = \sqrt{(c^2 - a^2)} \dots\dots\dots (2.9.12)$$

The distance from the apex of the sub reflector to the virtual focus (focus of the main parabola) behind the sub reflector is  $c - a$ .

The distance from the apex of the sub reflector to the phase center of the feed horn is  $c + a$ .

To eliminate feed horn blockage, the feed horn must be moved farther away from the sub reflector. There are two ways to move the feed horn without upsetting the geometry. One choice is a feed horn with a narrower beam, reducing angle  $\psi$  (recalculate  $f_{hyp}$ ); narrower beams require larger horn apertures. The other choice is a larger sub reflector, which increases the focal distance without changing angle  $\psi$ . This will increase blockage loss only, so the efficiency will decrease slightly and should be recalculated. The minimum sub reflector diameter to avoid feed horn blockage is

$$d_{sub} > d_{feed} \left( \frac{f_p}{f_{hyp}} \right) \dots\dots\dots (2.9.13)$$

The sub reflector must be in the far field of the feed horn which can be checked by Rayleigh Distance,

$$c + a > 2 \left( \frac{d_{feed}^2}{\lambda} \right) \dots\dots\dots (2.9.14)$$

If the sub reflector is in the near field of the feed, there will be significant phase error. The error decreases as the spacing approaches the Rayleigh Distance.

## 2.10 Radome

A **radome** is a structural, weatherproof enclosure that protects a microwave or radar antenna. The radome is constructed of material that minimally attenuates the electromagnetic signal transmitted or received by the antenna.

In other words, the radome is transparent to radar or radio waves. Radomes protect the antenna surfaces from the environment (e.g., wind, rain, ice, sand, ultraviolet rays etc.) and or conceal antenna electronic equipment from public view. They also protect nearby personnel from being accidentally struck by quickly-rotating antennas.

Radomes can be constructed in several shapes (spherical, geodesic, planar, etc.) depending upon the particular application using various construction materials (fiberglass, PTFE -coated fabric, etc.). When used on UAVs or other aircraft in addition to such protection, the radome also streamlines the antenna system, thus reducing drag. A radome is often used to prevent ice and freezing rain from accumulating directly onto the metal surface of the antennas as in the case of a spinning radar dish antenna. The radome also protects the antenna from debris and rotational irregularities due to wind.

For stationary antennas, excessive amounts of ice can de-tune the antenna to the point where its impedance at the input frequency rises drastically, causing voltage standing wave ratio (VSWR) to rise as well. This reflected power goes back to the transmitter, where it can cause overheating. A fold back circuit can act to prevent this; however, one drawback of its use is that it causes the station's output power to drop dramatically, reducing its range.

A radome prevents that by covering the antenna's exposed parts with a sturdy, weatherproof material, typically fiberglass, which keeps debris or ice away from the antenna to prevent any

serious issues. It is interesting to note that one of the main driving forces behind the development of fiberglass as a structural material was the need during World War II for radomes. When considering structural load, the use of a radome greatly reduces wind load in both normal and iced conditions. Many tower sites require or prefer the use of radomes for wind loading benefits and for protection from falling ice or debris.

## 2.11 18.5 GHz Main Reflector Design Values

Frequency band: K- band

Operative Frequency range: (17.3 – 19.7) GHz

$$\text{Centre Frequency } F_c = \frac{F_H + F_L}{2} = \frac{(17.3 + 19.7)}{2} = 18.5 \text{ GHz}$$

$$\text{Diameter : } D = 635 \text{ mm}$$

$$\frac{f}{D} = 0.3995$$

$$\text{Focal length of the Main Reflector } f = 253.6825 \text{ mm}$$

$$\text{Wavelength } \lambda = \frac{c}{F_c} = \frac{300}{18.5} = 16.216 \text{ mm}$$

$$\text{Depth of Dish, } d = \frac{D^2}{16f} = 99.3429 \text{ mm}$$

$A$  = physical area of the reflector

$$A = \frac{\pi D^2}{4} = 316692 \text{ mm}^2$$

$\eta$  = aperture efficiency /illumination efficiency

$$\text{Gain } G = 10 \log * \eta * \left( \frac{4\pi A}{\lambda^2} \right) = 41.799 \text{ dB}$$

$$\text{Parabola equation } y^2 = 4fx$$

$$\text{Then } x = \frac{y^2}{4f}$$

## 2.12 Main Reflector Contour Co-ordinates

Y (mm)	X (mm)
25	0.6159
50	2.4637
75	5.5433
100	9.8548
125	15.398
150	22.173
175	30.180
200	39.419
225	49.890
250	61.592
275	74.527
300	88.693
317.5	99.342

Table 2.1: Main Reflector Contour Co-ordinates

## 2.13 18 GHz Cassegrain Sub Reflector Design

### Design Values

$$D_p = \text{Parabolic Dish diameter} = 635 \text{ mm}$$

$$f_p = \text{Parabolic Dish Focal Length} = 253.6825 \text{ mm}$$

$$\frac{f}{D} \text{ Of Main Dish} = 0.3995$$

### Sub Reflector Geometry

$$\text{Magnification Factor } M = \frac{\text{Effective Feed } \left(\frac{f}{D}\right)}{\left(\frac{f_p}{D_p}\right)} = 4.7494$$

$$d_{sub} = \text{Sub Reflector Diameter} = 66.0123 \text{ mm}$$

$$f_{hyp} = \text{Focal length of hyperbola between foci} = 141.6341 \text{ mm}$$

$$\text{Dish illumination Half Angle } \psi = 2 \tan^{-1} \left( \frac{1}{4 \left(\frac{f}{D}\right)} \right) = 64.0752$$

$$\text{Angle blocked by sub reflector } \varphi_b = \sin^{-1} \left( \frac{d_{sub}}{2f_p} \right)$$

$$\text{Angle blocked by feed horn } \alpha = \tan^{-1} \left( \frac{d_{feed}}{2f_{hyp}} \right)$$

### Hyperbola Parameters :

$$a = 46.1824 \text{ mm}$$

$$b = 53.6865 \text{ mm}$$

$$c = 70.8171 \text{ mm}$$

Eccentricity

$$e = \frac{M + 1}{M - 1} = 1.5334$$
$$c = \frac{f_{hyp}}{2} = 70.8171 \text{ mm}$$
$$a = \frac{c}{e} = 46.1824 \text{ mm}$$

Space Attenuation of Parabolic Dish

$$(S.A)_{Dish} = 20 * \log \left( \frac{2}{1 + \cos(\psi)} \right) = 2.8703 \text{ dB}$$

Space Attenuation of Feed

$$(S.A)_{sub} = 20 * \log \left( \frac{2}{1 + \cos(\theta)} \right) = 0.1495 \text{ dB}$$

Adjusted illumination angle to get the desired taper  $\psi^1 = \psi \sqrt{\left( \frac{\text{taper in dB} - S.A_{Dish}}{10 - S.A_{sub}} \right)} = 60.6522$

Keheller's Universal Horn Equation,  $\psi^1 = \psi \sqrt{\text{Taper in dB}}$

Edge Taper  $E = 10^{\left( \frac{\text{Taper in dB}}{10} \right)} = 0.0677$

Approximate Sub-Reflector Efficiency

$$\eta_{sub} = \left[ 1 - C_b \left( 1 + 4 \left( 1 - \left( \frac{d_{sub}}{D} \right)^{1/2} \right) \right) \left( \frac{d_{sub}}{D} \right) \right]^2 = 0.8206$$

$$C_b = \frac{-\ln \sqrt{(E)}}{1 - \sqrt{(E)}}$$

Minimum Sub Reflector Diameter to avoid feed horn blockage = 66.0123 mm

### Sub Reflector Position:

Apex to Dish Focal point = 24.6347 mm

Apex to Feed Phase Center = 1116.9995 mm

Equation of the Hyperbola is  $\frac{x^2}{a^2} - \frac{y^2}{b^2} = 1$

Then  $x = \sqrt{a^2 \left( 1 + \frac{y^2}{b^2} \right)}$

## 2.14 Sub Reflector Contour Co-ordinates

Radius Y (mm)	X (mm)
0	8.86
4.01	7.84
8.05	7.77
12.08	7.38
16.11	6.91
20.13	6.44
24.17	5.97
28.20	5.50
32.23	4.98

Table 2.2: Sub Reflector Contour Co-ordinates

## 2.15 Summary

This chapter concludes with the design of main reflector, sub reflector and feed horn with relevant procedure and calculations.

**CHAPTER 3**  
**ITERATIVE LOCAL SEARCH**  
**ALGORITHM**



## 3.1 Iterated Local Search algorithm

Iterated Local Search is a Meta heuristic and Global Optimization technique. It is an extension of Multi Start Search and may be considered a parent of many two-phase search approaches such as the Greedy Randomized Adaptive Procedure and Variable Neighborhood Search.

### 3.1.1 Strategy

The objective of Iterated Local Search is to improve upon stochastic Multi-Restart Search by sampling in the broader neighborhood of candidate solutions and using a Local Search technique to refine solutions to their local optima. Iterated Local Search explores a sequence of solutions created as perturbations of the current best solution, the result of which is refined using an embedded heuristic.

### 3.1.2 Pseudo code for Iterated Local Search.

Input:

Output:  $S_{best}$

$S_{best} \leftarrow$  Construct Initial Solution ();

$S_{best} \leftarrow$  Local Search ();

Search History  $\leftarrow S_{best}$ ;

While  $\neg$  Stop Condition () do

$S_{candidate} \leftarrow$  Perturbation ( $S_{best}$ , SearchHistory);

$S_{candidate} \leftarrow$  Local Search ( $S_{candidate}$ );

Search History  $\leftarrow S_{candidate}$ ;

If Acceptance Criterion ( $S_{best}, S_{candidate}$  SearchHistory) then

$S_{best} \leftarrow S_{candidate}$ ;

End

End

Return  $S_{best}$ ;

### 3.1.3 Heuristics

- Iterated Local Search was designed for and has been predominately applied to discrete domains such as combinatorial optimization problems.
- The perturbation of the current best solution should be in a neighborhood beyond the reach of the embedded heuristic and should not be easily undone.
- Perturbations that are too small make the algorithm too greedy, perturbations that are too large make the algorithm too stochastic.
- The embedded heuristic is most commonly a problem-specific local search technique.
- The starting point for the search may be a randomly constructed candidate solution, or constructed using a problem-specific heuristic (such as nearest neighbor).
- Perturbations can be made deterministically, although stochastic and probabilistic (adaptive based on history) are the most common.
- The procedure may store as much or as little history as needed to be used during perturbation and acceptance criteria. No history represents a random walk in a larger neighborhood of the best solution and is the most common implementation of the approach.
- The simplest and most common acceptance criteria are an improvement in the cost of constructed candidate solutions.

**CHAPTER 4**

**ANALYSIS OF CASSEGRAIN ANTENNA  
USING GRASP SOFTWARE**

# GRASP 10

## (GENERAL REFLECTOR ARRAY SOFTWARE PACKAGE)

### 4.1 Introduction

The radiation of the whole antenna system is analyzed with TICRA's GRASP software. It uses both physical optics (PO) and geometric optics (GO) to compute reflection from surfaces that are electrically large, i.e., at least several wavelengths in some dimension. Both PO and GO methods are very computationally efficient, thus very large systems can be analyzed. For example, single reflector systems that are several tens of wavelengths in size are analyzed within a few minutes using an ordinary personal computer.

Radiation from the equivalent or induced surface currents on a reflector is quite straight forward to calculate. However, determining these currents exactly (e.g., using Method of Moments) is computationally very laborious if the surface is electrically large. In that case induced currents can be approximated using the much simpler PO method. In the PO approximation it is assumed that the surface current on an infinite planar surface being tangential to the scattering surface at that point.

However, this assumption is not valid on the surface edges, and infinite half plane wave models is used there to produce physical theory of diffraction (PTD) currents. Combining PO and PTD yields to very accurate results if a sufficiently dense integration grid for radiation integrals is used. After calculating the scattered field from the reflector, the total radiated field is obtained by adding incident field from the feed.

A GRASP simulation can include multiple reflectors and multiple feeds. Any second degree surface can be defined as a reflector with arbitrary rim shape; however most common reflectors and rims are included as predefined models.

In order to obtain a full radiation pattern, both PO and GO need to be used. If accurate results far from the main beam are needed, PO becomes inefficient due to an extremely large integration grid while GO is still efficient. As a rule of thumb, PO is used within and near the main beam, whereas GO is need elsewhere.

GRASP 10 is a set of tools for analyzing general reflector antennas and antenna farms. It contains three main components:

1. A pre-processor which assists the user in setting up the antenna geometry, in specifying the type of analysis to be performed and in visualizing the system. In addition the pre-processor provides a plotting facility for simple 2D-plots of pattern cuts and contours.
2. An analysis module which performs the electromagnetic analysis and calculates data used for visualization.
3. A post-processor containing several data-processing and plotting facilities for calculated patterns. Plots can be in the form of pattern cuts or in the form of contour plots in various projections.

The electromagnetic methods which may be applied for the analysis are

- Physical Optics (PO) with Physical Theory of Diffraction (PTD)
- Geometrical Optics (GO) and Geometrical Theory of Diffraction (GTD)
- Spherical Wave Expansion (SWE)
- Plane Wave Expansion (PWE)
- Methods of Moments (MoM)

It contains four tabs for analysis of the reflector system

1. **Objects:** In which the geometry of the antenna as well as the methods of calculation are defined.
2. **Command:** In which commands for the analysis are given
3. **Jobs:** In which the analysis is started and previous analyses may be reviewed.
4. **Results:** In which the results of the analysis are shown.

## 4.2 Dual Reflector with Blockage

In this we are designing rotationally symmetric dual reflector antenna system. In such this the blockage due to the sub reflector must be accurately modeled, since this can have significant influence on the gain and side lobes. Moreover, the spillover from the feed must be included in the computations because it can significantly contribute to the radiation pattern.

With the purpose of making the sub reflector blockage and feed spillover effects easily perceived, the dimensions of the antenna are exaggerated relative to the traditional design.

Areal dual reflector would of course need some sort of support for the sub reflector, but this is here neglected.

GRASP 10 Simulation involves

- Navigating in the pre-processor windows
- Defining the geometry of standard, double reflector systems
- Getting an overview of the objects and commands created
- Performing a PO-analysis of the reflector system
- Viewing the calculated radiation pattern

### **4.3 Subreflector Blockage**

Another contribution that needs to be considered is the subreflector blocking the nominal field from the main reflector. There are two approaches for this analysis:

1. The main reflector area behind the subreflector, hence, the area invisible from the boresight direction, is replaced by a hole, i.e. the currents in this area shall not contribute to the field. This is a fast approach but only close to boresight.
2. The current on the subreflector generated by letting the main reflector field illuminated the subreflector are calculated. The fields from these currents are added to the far field. This approach is accurate but time consuming relative to the first approach.

### **4.4 Visualizing the geometry**

GRASP 10 contains two different ways of visualizing 3D-data for the system geometry. The OpenGL Plot, where the plotting is performed using the OpenGL graphics library to generate plots where the geometry is shown as wire-grids or solid surfaces. The Object Plot, where the plots are shown as wire grids.

Select Command list then we get a dialog box click submit. Clicking the submit button now launches the analysis module. Two browser windows prompts the user to give the names of an output file and a log file. Following these definitions the analysis is launched. The progress of the analysis is displayed in a command window as shown in Figure 3.9. The analysis is completed when the message Press Enter to Continue is shown in the command line window. Press Enter to close the window. The result of the analysis is a field calculation in two cuts in the far field. The result is stored in the file named sph\_1cut. We can now plot the result in GRASP 10 by clicking Commands ► Plot commands.

#### 4.4.1 Visualizing the Geometry as an OpenGL Plot

A useful way of viewing the geometry is to use the OpenGL plots available in GRASP 10. The plotting is performed using the OpenGL graphics library. It is possible to rotate, translate and zoom the geometry using a combination of keystrokes and mouse movements.

To visualize the geometry as an OpenGL plot

In the main menu, click Commands. ► Plot Commands ► OpenGL, all objects. The OpenGL plot of objects window opens with a plot of the reflector configuration. The reflector and feed horn are shown in grey which can be seen in Fig 3.10. The red, green and blue lines illustrate the x-, y- and z-axes of the coordinate systems defined.

It is possible to:

- Rotate the configuration by dragging the mouse
- Zoom by holding the Shift-key and dragging the mouse up (zoom in) or down (zoom out)
- Translate the configuration by holding the Ctrl-key and dragging the mouse

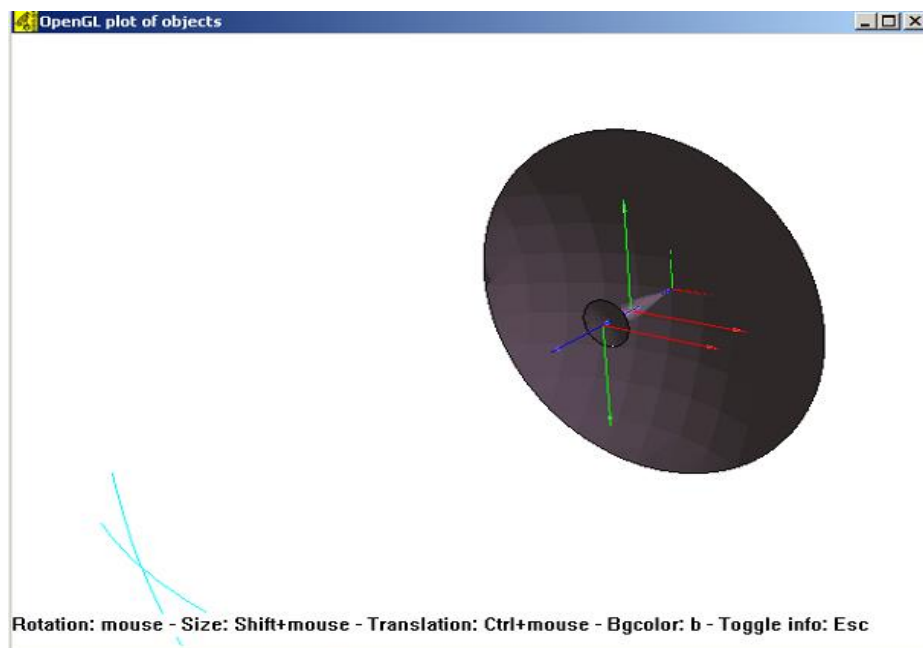

Figure 4.1: Open GL Plot

Using OpenGL in the pre-processor, the geometry is plotted as seen from an observer close to the reflector system. As a consequence, it is not possible to visualize a projection of the geometry onto a plane, e.g. one of the coordinate planes. This can be accomplished using the Object Plot in the pre-processor.

#### 4.4.2 Visualizing the Geometry as an Object Plot

In the Object Plot the 3D geometry is plotted as seen from an observer infinitely far from the reflector system. Hence, this visualization yields projections of the geometry.

To plot the geometry as an object plot

In the main menu, click Commands. ► Plot Commands ► Plot all objects. The Object plot window opens with a plot of the reflector configuration. There is no limit on the number of Object plot windows, which can be opened at a given time.

#### 4.4.3 Radiation Pattern

The GRASP 10 objects define the geometry, the electromagnetic sources and the way to analyze the reflector system. However, we need to specify which electromagnetic computation should be carried out and in which order. This is done using the GRASP10 Commands. The Command list shows a list of commands to be executed by the analysis module. The commands are executed sequentially in the order specified in the Command list. To open the command list. In the main menu bar, click Commands. ► Command list ► Plot 2D cut. This opens the Plot 2D cut window. Click File ► Open to select the sph\_1.cut.

The radiation patterns at different frequencies are observed i.e., at 17.3 GHz, 18 GHz, 18.5 GHz, 19 GHz and 19.7 GHz as shown in Fig , Fig 3.17, Fig 3.19 and Fig 3.20.

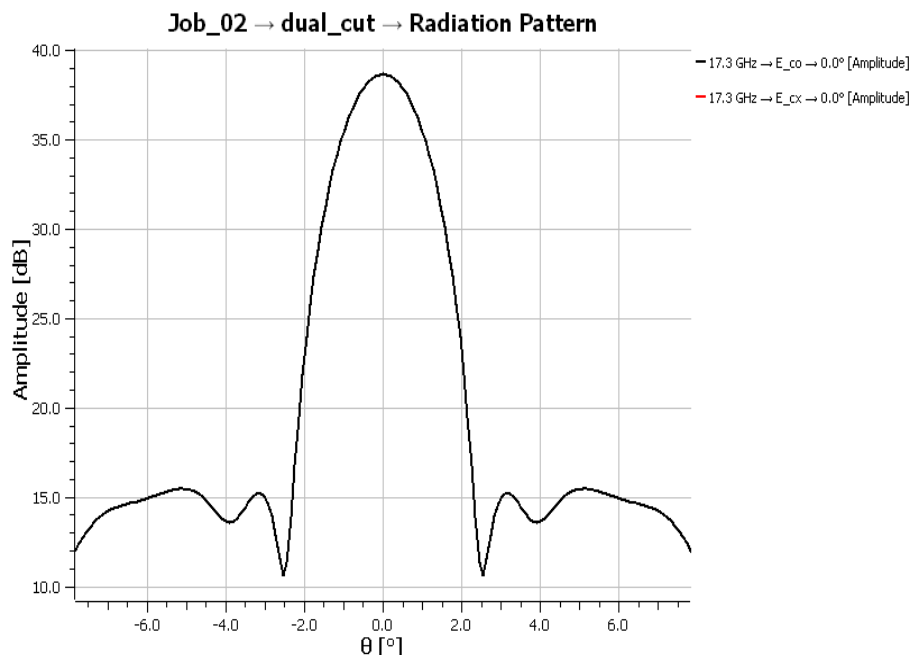

Figure 4.2: Radiation pattern at a frequency 17.3 GHz



Relative Power Scattered by sub reflector (%)	Spillover (dB)	Relative Power Scattered by main reflector (%)	Spillover (dB)	Main lobe Magnitude (dB)	I side lobe Magnitude (dB)	II side lobe Magnitude (dB)
0.7818	1.0689	0.7350	1.3368	38.6273	15.2232	15.4420

Table 4.1: Tabular form of radiation values at a frequency 17.3 GHz.

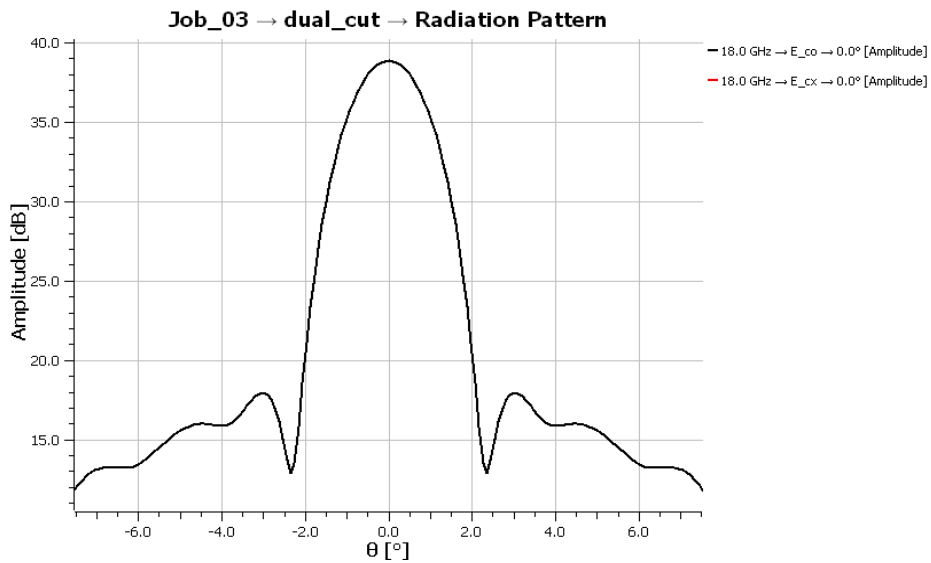

Figure 4.3: Radiation pattern at a frequency 18 GHz

Relative Power Scattered by sub reflector (%)	Spillover (dB)	Relative Power Scattered by main reflector (%)	Spillover (dB)	Main lobe Magnitude (dB)	I side lobe Magnitude (dB)	II side lobe Magnitude (dB)
0.793483	1.004	0.745871	1.2734	38.8184	17.86	15.83

Table 4.2: Tabular form of radiation values at a frequency 18 GHz.

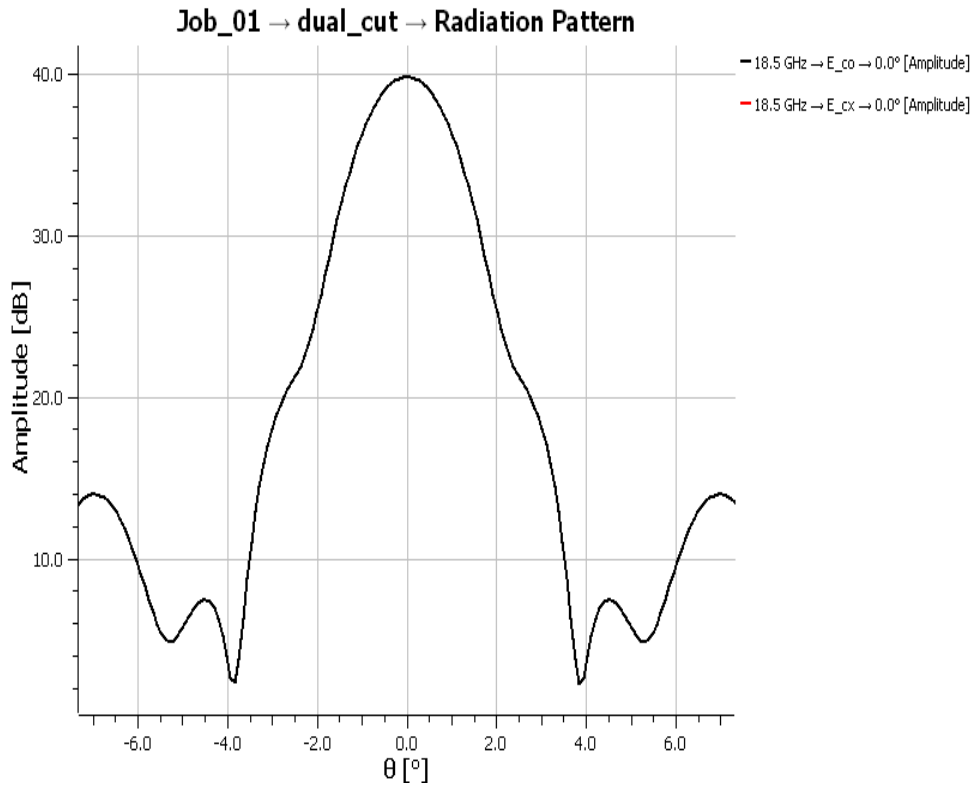

Figure 4.4: Radiation pattern at a frequency 18.5 GHz

Relative Power Scattered by sub reflector (%)	Spillover (dB)	Relative Power Scattered by main reflector (%)	Spillover (dB)	Main lobe Magnitude (dB)	I side lobe Magnitude (dB)	II side lobe Magnitude (dB)
0.813007	0.8991	0.771328	1.276	39.8779	7.4245	13.9346

Table 4.3: Tabular form of radiation values at a frequency 18.5 GHz.

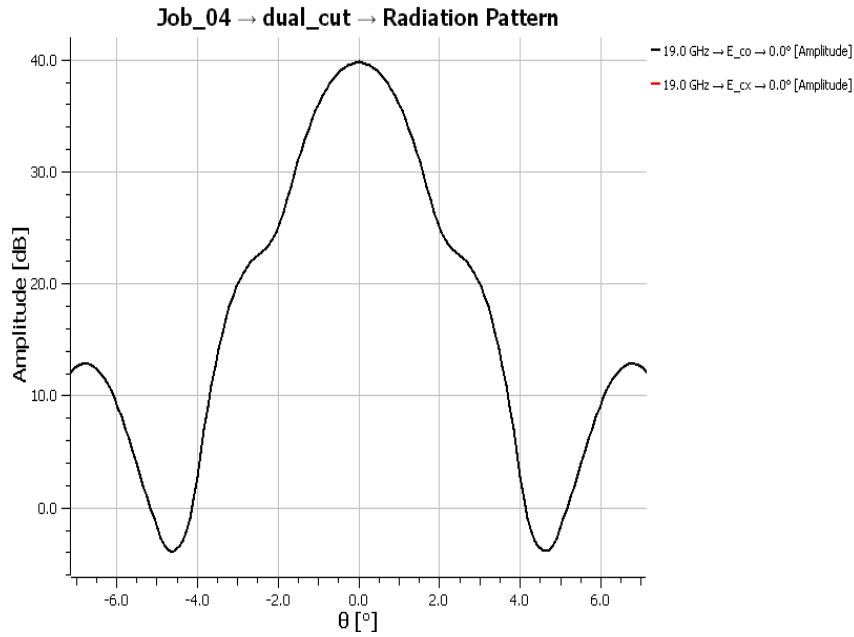

Figure 4.5: Radiation pattern at the frequency 19 GHz

Relative Power Scattered by sub reflector (%)	Spillover (dB)	Relative Power Scattered by main reflector (%)	Spillover (dB)	Main lobe Magnitude (dB)	I side lobe Magnitude (dB)	II side lobe Magnitude (dB)
0.808174	0.9250	0.764207	1.1679	39.84	22.19	12.6938

Table 4.4: Tabular form of radiation values at a frequency 19 GHz.

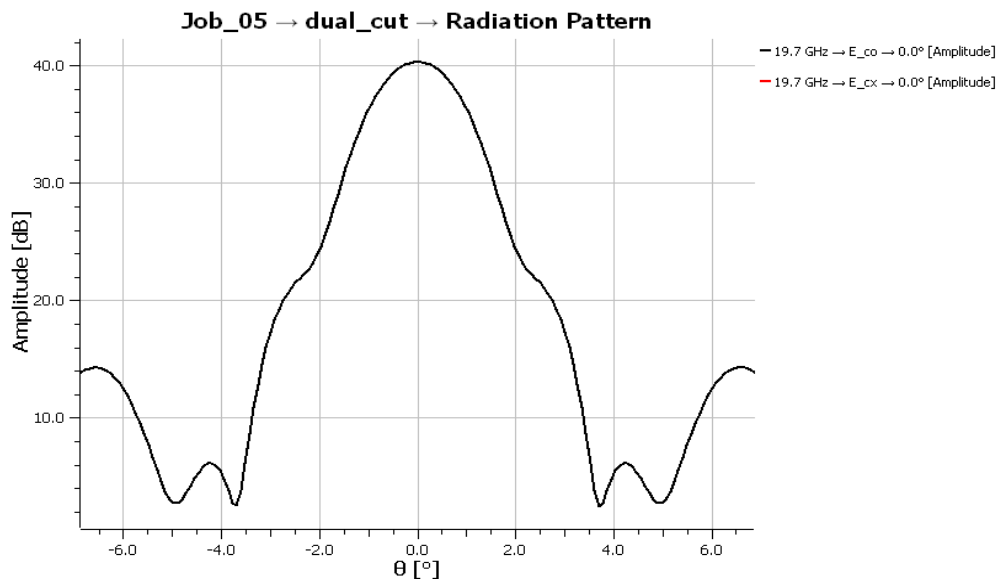

Figure 4.6: Radiation pattern at a frequency 19.5 GHz

Relative Power Scattered by sub reflector (%)	Spillover (dB)	Relative Power Scattered by main reflector (%)	Spillover (dB)	Main lobe Magnitude (dB)	I side lobe Magnitude (dB)	II side lobe Magnitude (dB)
0.817258	0.8764	0.7775	1.0929	40.3962	21.1978	6.0154

Table 4.5: Tabular form of radiation values at the frequency 19.5 GHz.

Frequency (GHz)	3 dB Beam width (°)	Gain (dBi)
17.3	1.7	38.62
18	1.6	38.82
18.5	1.6	39.88
19	1.7	39.84
19.7	1.8	40.39

Table 4.6: Tabular Form of beam width and gains with varying frequencies

## 4.5 Summary

GRASP simulation software is used and Gain versus Frequency, 2D-radiation pattern, side lobe level, Beam width are calculated at a frequency band (17.3 GHz -19.7 GHz).

Different materials used for fabrication of Cassegrain Reflector antenna and their advantages are

## 4.6 Aluminum alloys

### Advantages

- Good mechanical behavior.
- Light Weight
- Good corrosion resistance.
- Low wind pressure
- Easy to fabricate and assemble
- Ability to conform to different shapes

## **4.7 RF Absorber**

### **Advantages**

- Light weight
- Flexible
- Flat sheet broad band absorber
- Electrically conductive
- Reticulated open cell polyurethane foam sheet with a controlled conductivity gradient carbon loading system
- Frequency range from 8-26.5 GHz

The final additional component that is added to create a high performance microwave antenna is the Radome. The radome serves two purposes. One is to protect the inside of the antenna from the elements. The second purpose is to reduce what would otherwise be significant wind loading on the antenna due to the shroud catching if not for the radome. The Radome is made up of Forex material and the radome is fixed by using plastic rivets.

High performance antennas are characterized by low VSWR, high efficiency feed horn and by a tight profile tolerance of the reflector. All High performance antennas are equipped with plane flexible radomes mounted on cylindrical shields whose internal surfaces are covered with absorbing material in order to minimize the spillover loss and hence wide angle and back lobes. High performance antennas are installed in very crowded microwave networks where the use of antennas are characterized by the peculiarity of exceptionally good values of cross-polarization discrimination in a solid angle centered around the antenna axis.

Among the innovative and conventional foundry processes for aluminum alloys, low pressure die casting is characterized by several advantages including high yield excellent control of operative parameters. This type of antenna is used in microwave point to point links and it makes the transmission easy by avoiding cables.

## **5. RESULTS**

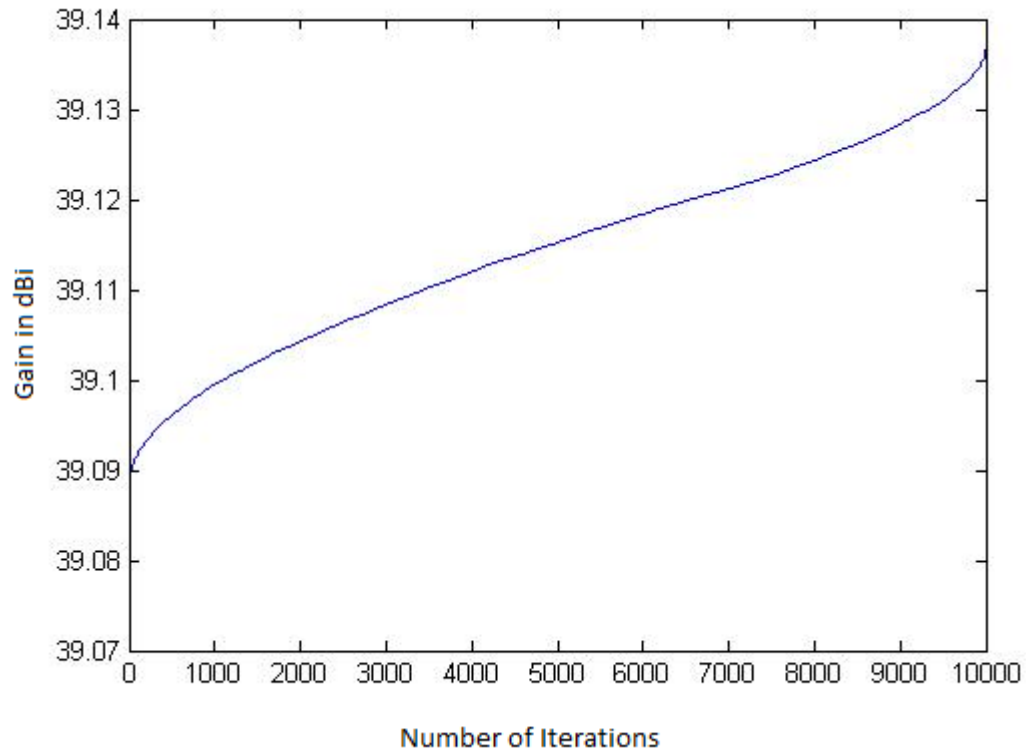

Figure 5.1: Gain vs. Number of iterations by using Iterative Local Search Algorithm

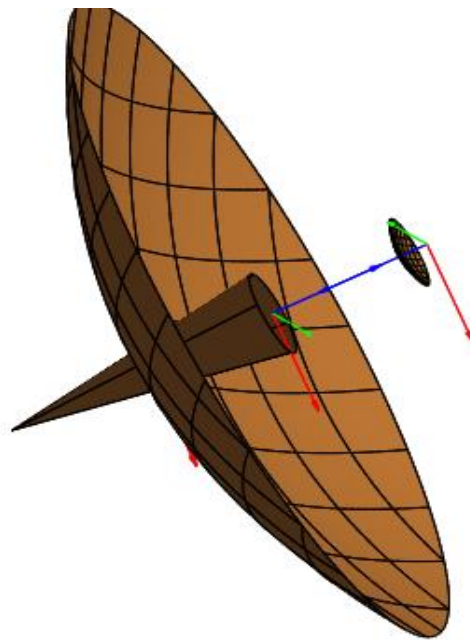

Figure 5.2: 3-D View of the Cassegrain Reflector Antenna

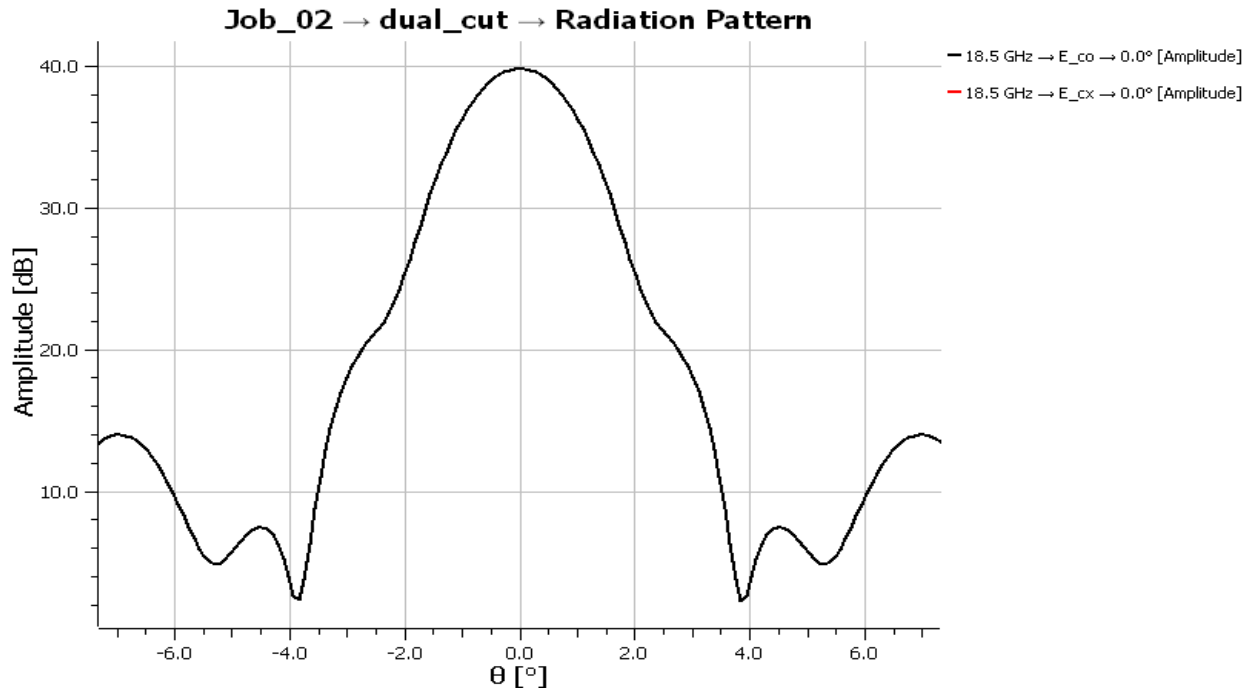

Figure 5.3: E-field Radiation pattern at frequency 18.5 GHz with constant  $\phi = 0^\circ$

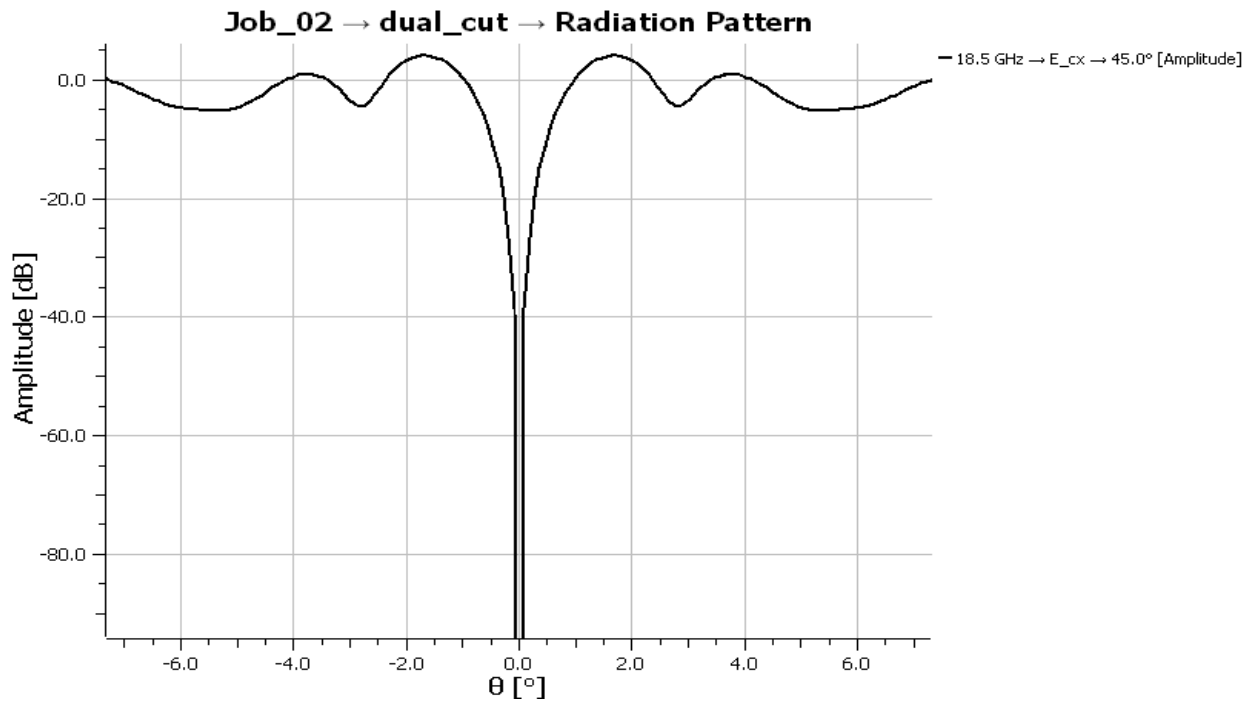

Figure 5.4: E-field cross polarization at frequency 18.5 GHz with constant  $\phi = 45^\circ$



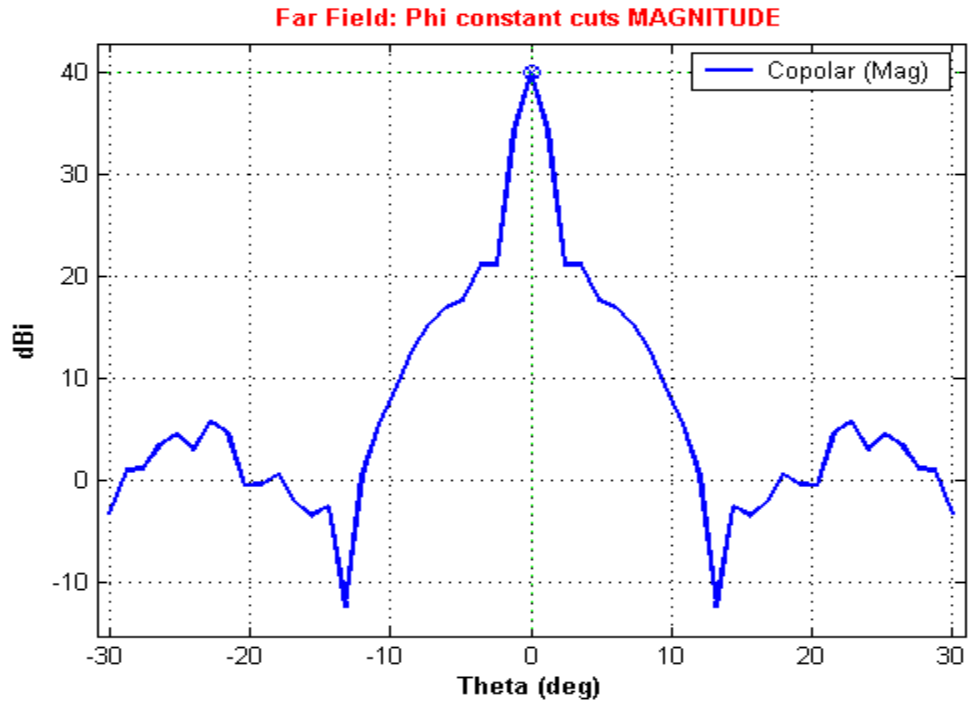

Figure 5.5: Far field ' $\phi$ ' constant magnitude cuts using ICARA

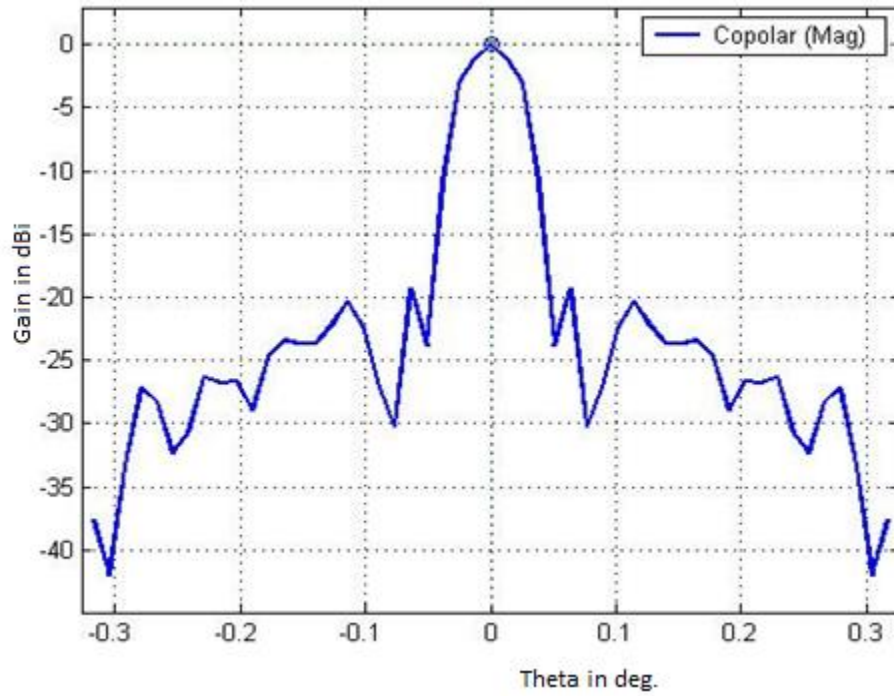

Figure 5.6: Near field ' $\phi$ ' constant magnitude cuts using ICARA

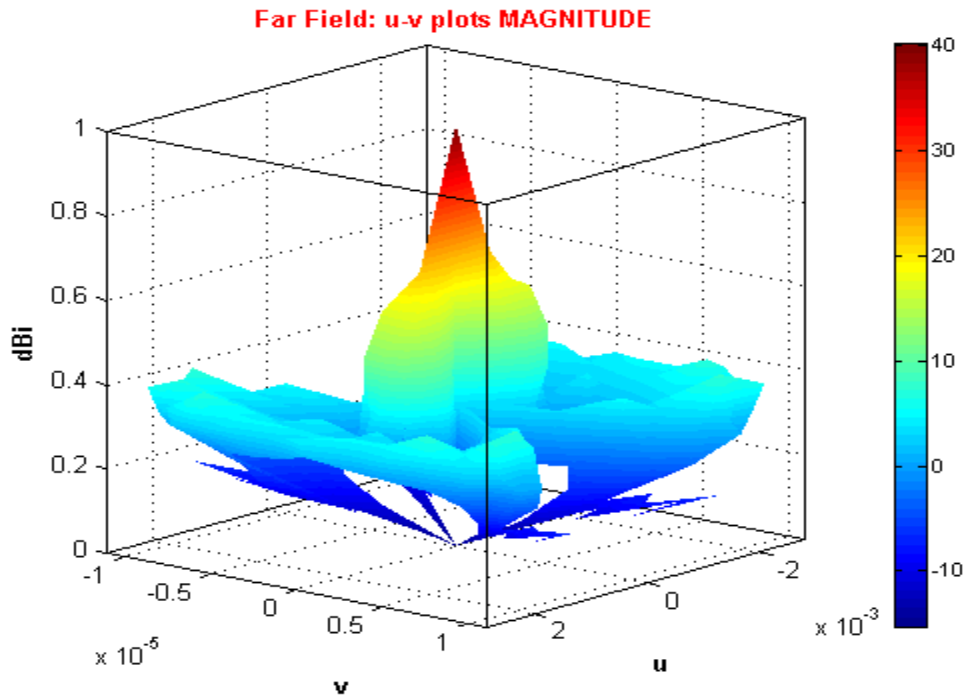

Figure 5.7: Co-polar magnitude plot

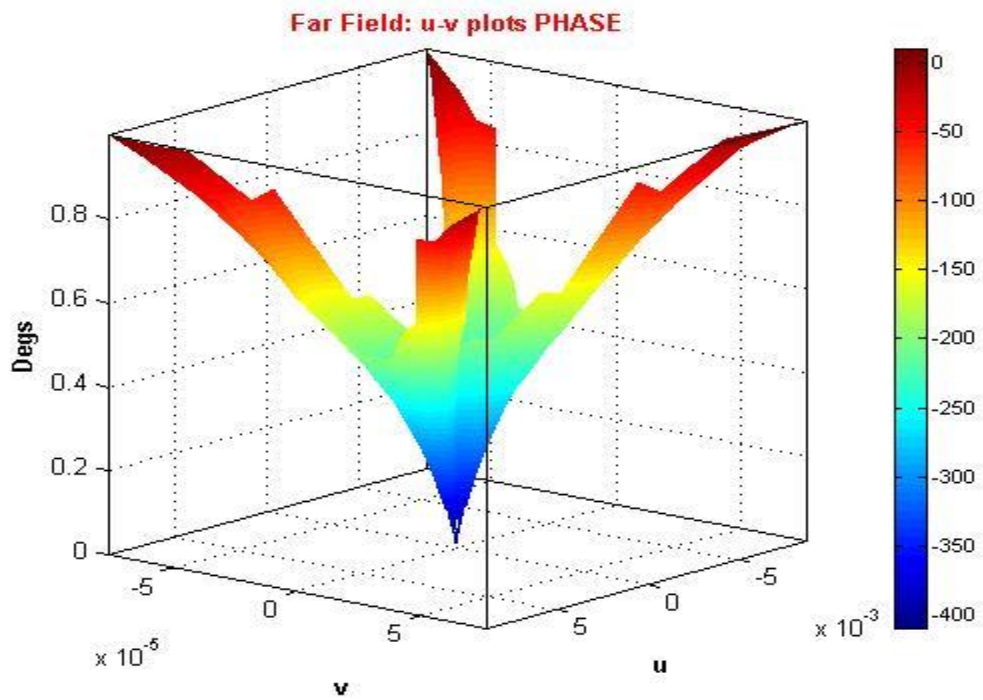

Figure 5.8: Co-polar phase plot

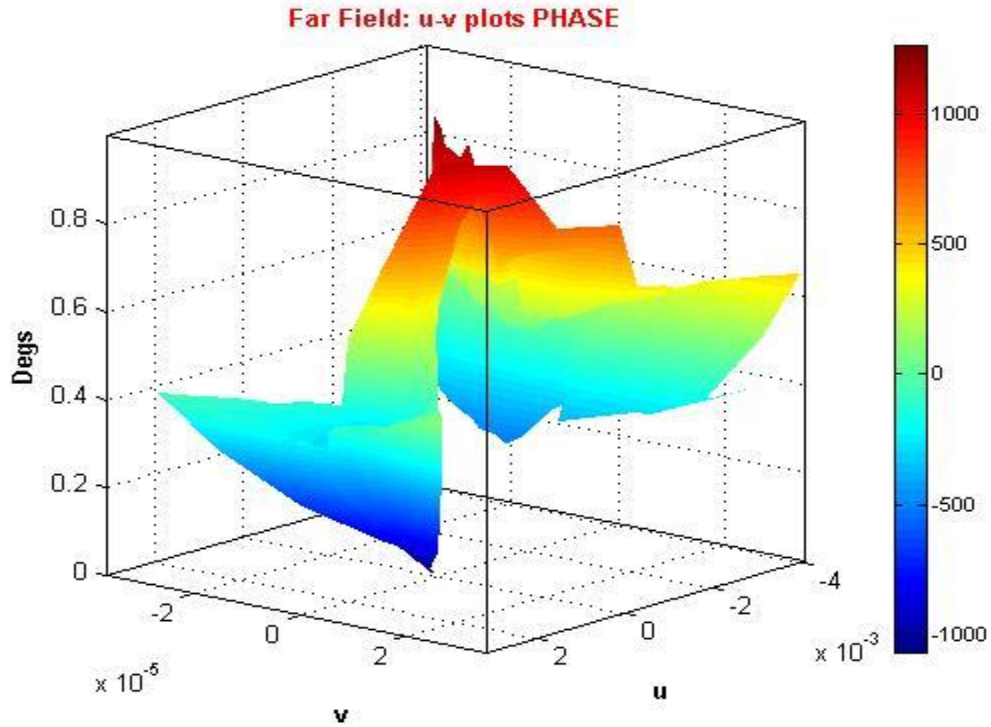

Figure 5.9: Far field cross polarization phase plot

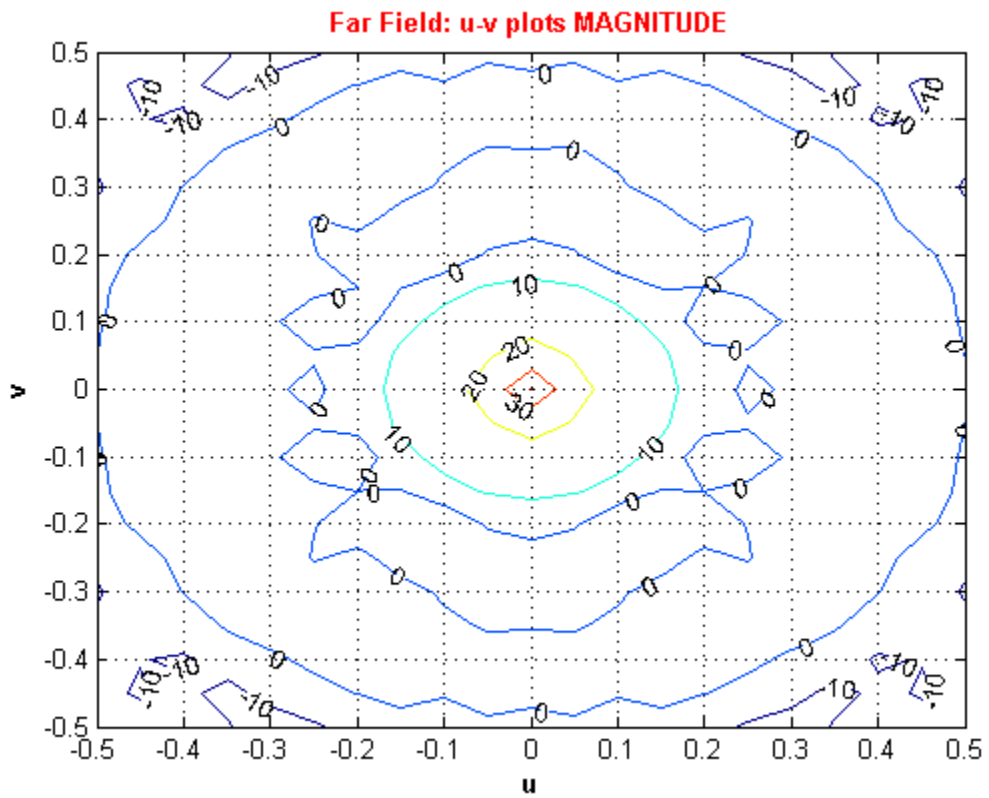

Figure 5.10: Far field co-polarization magnitude contours

**CHAPTER 6**  
**CONCLUSION**  
**&**  
**FUTURE SCOPE**

## 6.1 Conclusions

- The experimental results obtained during this investigation demonstrate a promising new approach to the design of antenna with narrow beam width. The method described provides a means of obtaining linearly polarized antenna having approximately equal and constant principal plane beam widths over bandwidths of 17.3-19.7 GHz. Reflector antenna with good performance from the point of view of gain, bandwidth, beam width, CPD etc., can be designed by optimizing its geometry.
- The side lobes are controlled with the help of the absorbing material. Soft computing is carried out in the frequency band (17.3-19.7 GHz), with the given specifications.

## 6.2 Future Scope of the Project

Modern microwave links are quite prevalent due to the cost effective nature of utilizing microwave point-to-point links to relay traffic compared to wire-line rental rates and fiber usage. Wireless microwave links also serve as excellent backup to fiber-optic links. With the introduction of new and affordable digital technologies, licensed and unlicensed spread spectrum microwave data links, this type of antenna serve many specials markets including in building wireless LANs, point to multipoint internet, regional broadcast subscriber services.

Typical applications

- Microwave data links
- Broadband wireless applications
- Point to point communications

However, for modern high frequency microwave radio systems requiring high efficiency in a smaller package, the cassegrain sub reflector antenna is most applicable. Due to the sophisticated technology, this type of antenna is used for many applications especially for Microwave point to point links and the design at different frequencies can be done due to the overwhelming demand of Network providers. These types of antennas are used up to 220 GHz.

## REFERENCES

- [1] Constantine.A.Balanis,"*Antenna Theory and Design*", Second edition, 1997, John Wiley Publications.
- [2] Thomas Milligan, "*Modern Antenna Design*", McGraw-Hill, 1985, pp. 239-249.
- [3] Krunal Patel, "Designing Optimized Cassegrain with Balanced Feed", *ICWET, International Journal of Computer Applications (IJCA)*, 2011.
- [4] Gorji, B.A.; Zakeri, B., "Design approach for axially symmetric dual-reflector small cassegrain antenna considering mechanical implementation constraints," *Radar (Radar), 2011 IEEE CIE International Conference on* , vol.1, no., pp.304,307, 24-27 Oct. 2011
- [5] Begum, S.R.U.; Ramakrishna, D.; Prameelamma, C.; Pandharipande, V. M., "Design and development of 18 GHz reflector antenna for microwave point to point links," *India Conference (INDICON), 2011 Annual IEEE* , vol., no., pp.1,6, 16-18 Dec. 2011
- [6] Kildal, P- S., "The effects of sub reflector diffraction on the aperture efficiency of a conventional Cassegrain antenna--An analytical approach," *Antennas and Propagation, IEEE Transactions on*, vol.31, no.6, pp.903, 909, Nov 1983.
- [7] Granet, C., "Designing axially symmetric Cassegrain or Gregorian dual-reflector antennas from combinations of prescribed geometric parameters," *Antennas and Propagation Magazine, IEEE* , vol.40, no.2, pp.76,82, Apr 1998
- [8] Christophe Granet, "Designing Axially Symmetric Cassegrain or Gregorian Dual-Reflector Antennas from Combinations of Prescribed Geometric Parameters, Part 2: Minimum Blockage Condition While Taking into Account the Phase Center of the Feed," *IEEE Antennas and Propagation Magazine*, June 1998, pp. 82-85.
- [9] P.J. Wood, "Reflector antenna analysis and design", *Peter Peregrinus*, 1980, pp.156-157.
- [10] Allan W.Love,"*Reflector Antennas*", *IEEE press*, 1978, New York.
- [11] Per-Simon Kidal, "Foundations of Antennas--A unified approach", *Student literature*,2000

- [12] Jeffrey M. Lichtman, "Methods of determining the antenna focal point," *Radio Astronomy Supplies, Application note 8*, October 2002.
- [13] GRASP 10 Manual, TICRA.
- [14] Karimkashi, S.; Rashed-Mohassel, J., "Minimization of blockage in axially symmetric dual-reflector antennas," *Microwave Conference Proceedings, 2005. APMC 2005. Asia-Pacific Conference Proceedings*, vol.4, no., pp.3 pp., 4-7 Dec. 2005
- [15] Paul Wade, "Multiple Reflector Dish Antennas", W1GHZ,2004
- [16] Rathod, J.M.; Kosta, Y. P., "Low cost design & development of conical horn feed for parabolic reflector antenna," *Recent Advances in Microwave Theory and Applications, 2008. MICROWAVE 2008. International Conference on*, vol., no., pp.775,777, 21-24 Nov. 2008
- [17] K.D Prasad, "Antennas and wave propagation" Second Edition, 1999.
- [18] Andy Singer, "High performance antenna design", Mobile Radio Technology, The official magazine of IWCE.
- [19] Moreira, F.J.S.; Prata, A., Jr., "Design of axially-symmetric Cassegrain and Gregorian configurations with reduced spillovers," *Antennas and Propagation Society International Symposium, 1998. IEEE*, vol.2, no., pp.820,823 vol.2, 21-26 June 1998
- [20] Jenn, D.C.; Vered, N.; Ordonez, M., "Small efficient axially symmetric dual reflector antennas," *Antennas and Propagation, IEEE Transactions on*, vol.41, no.1, pp.115,117, Jan 1993
- [21] ICARA Manual, ICARA.