

# Implementation of single phase watt hour meter using LPC2148

Parmanand Nayak



Department of Electronics and Communication Engineering  
National Institute of Technology Rourkela  
Rourkela – 769 008, India

# Implementation of single phase watt hour meter using LPC2148

*Dissertation submitted in*

*May 2013*

*to the department of*

***Electronics and Communication Engineering***

*of*

***National Institute of Technology Rourkela***

*in partial fulfillment of the requirements*

*for the degree of*

***Master of Technology***

*by*

***Parmanand Nayak***

*(Roll 211EC3316)*

*under the supervision of*

***Prof. KamalaKanta Mahapatra***



Department of Electronics and Communication Engineering

National Institute of Technology Rourkela

Rourkela – 769 008, India



Electronics and Communication Engineering  
**National Institute of Technology Rourkela**

Rourkela-769 008, India. [www.nitrkl.ac.in](http://www.nitrkl.ac.in)

**Prof. KamalaKanta Mahapatra**

Professor

May 30, 2013

## Certificate

This is to certify that the work in the thesis entitled *Implementation of single phase watt hour meter using LPC2148* by *Parmanand Nayak*, bearing roll number 211EC3316, is a record of an original research work carried out by him under my supervision and guidance in partial fulfillment of the requirements for the award of the degree of *Master of Technology* in *Electronics and Communication Engineering*. Neither this thesis nor any part of it has been submitted for any degree or academic award elsewhere.

***Prof. Kamala Kanta Mahapatra***

## Acknowledgment

This dissertation, though an individual work, has benefited in various ways from several people. Whilst it would be simple to name them all, it would not be easy to thank them enough.

The enthusiastic guidance and support of *Prof. KamalaKanta Mahapatra* inspired me to stretch beyond my limits. His profound insight has guided my thinking to improve the final product. My solemnest gratefulness to him.

My sincere thanks to *Prof. Ayas Kanta Swain* for their continuous encouragement and invaluable advice.

Many thanks to my comrades and fellow research colleagues. It gives me a sense of happiness to be with you all.

Finally, my heartfelt thanks to my family for their unconditional love and support. Words fail me to express my gratitude to my beloved parents, who sacrificed their comfort for my betterment.

*Parmanand Nayak*

## Abstract

The *LPC2148* device is the latest system-on-chip (SOC), which belongs to the ARM generation of devices. This generation of devices belongs to the powerful 32-bit ARM platform bringing in a lot of new features and flexibility to support robust single, two and 3-phase metrology solutions. This thesis however, discusses the implementation of 1-phase solution only. These devices find their application in energy calculation and have the necessary architecture to support them.

Furthermore, for large scale manufacturing, the costs can become lower than those of the electromechanical meters currently in production. This device presents a totally electronic single phase energy meter for residential use, based on ARM processor. A four digit display is used to show the consumed power. A prototype has been implemented to adequate measurement up to 5A load current from a 230V (phase to neutral) voltage. Higher current capacity can be easily obtained by simply replacing the shunt resistor. And, by changing the transformer tap and the voltage divider ratio, it can be easily manipulated for use in a 220 V supply.

The *LPC2148* has a powerful 60 MHz CPU with ARM architecture. The analog front end consists of up to two channel of 10-bit analog-to-digital converters (ADC) based on a successive approximation architecture that supports differential inputs, with conversion time 2.44 micro second per channel. The ADCs operate independently and are capable to output 10-bit result. They can be grouped together for simultaneous sampling of voltage and currents on the same trigger. A 32-bit x 32-bit hardware on this chip can be used to further accelerate math intensive operations during energy calculation. The software supports calculation of various parameters for single phase energy calculation. The key parameters measured during energy measurements are: RMS current and voltage, energies. Alternatively, the design is ease to fits more computerized applications with features such as remote reading , demand recording, multiple tariffs, checking, and other.

**Keywords:** *LPC2148 processor, step down transformer, Variable load,current transducer, operational amplifier, 16X2 LCD.*

# Contents

<b>Certificate</b>	<b>ii</b>
<b>Acknowledgement</b>	<b>iii</b>
<b>Abstract</b>	<b>iv</b>
<b>List of Figures</b>	<b>viii</b>
<b>List of Tables</b>	<b>x</b>
<b>1 Introduction</b>	<b>1</b>
1.1 Objective . . . . .	2
1.2 Scope of Project . . . . .	2
1.3 Purpose and Description of Project . . . . .	2
1.4 Literature Review . . . . .	3
1.5 Contributions . . . . .	5
<b>2 MEASUREMENT OF ENERGY RELATED QUANTITIES</b>	<b>6</b>
2.1 General Theory and Principles . . . . .	6
2.1.1 Real Power . . . . .	6
2.1.2 Apparent Power . . . . .	7
2.1.3 Power Factor . . . . .	7
2.1.4 Reactive Power . . . . .	8
2.1.5 Power and Impedance triangle . . . . .	14

2.2	Operational Considerations . . . . .	14
2.2.1	Current Sensing . . . . .	16
2.2.2	Hall Effect . . . . .	17
2.2.3	Hall Effect Sensor . . . . .	17
2.2.4	Current Inputs . . . . .	17
2.2.5	Voltage Sensing . . . . .	19
2.2.6	Voltage Division . . . . .	19
2.2.7	Voltage Transformer . . . . .	20
2.2.8	Voltage Inputs . . . . .	21
2.2.9	Data Analysis and Display . . . . .	22
<b>3</b>	<b>DESIGN OF MEASUREMENT SYSTEM AND DATA DISPLAY</b>	<b>24</b>
3.1	General Design Procedure . . . . .	24
3.2	Hardware Design . . . . .	25
3.2.1	ARM processor (LPC2148) . . . . .	26
3.2.2	Hall Effect Sensor . . . . .	30
3.2.3	TL081 Op Amp . . . . .	31
3.2.4	LCD . . . . .	32
3.3	Software Development . . . . .	33
3.3.1	Peripherals Set Up . . . . .	33
3.3.2	The Foreground Process . . . . .	35
3.3.3	The Formulae . . . . .	36
3.3.4	The Background Process . . . . .	38
<b>4</b>	<b>EXPERIMENTAL RESULTS</b>	<b>40</b>
4.1	Testing Voltage and Current sensing Circuit . . . . .	40
4.2	Testing for samples . . . . .	41
4.3	Tests for sag of signal . . . . .	42
4.4	Tests on Current measurement . . . . .	43
4.5	Tests on Voltage measurement . . . . .	44

4.6 Tests on Consumed Energy measurement . . . . .	45
<b>5 Conclusion</b>	<b>47</b>
<b>Bibliography</b>	<b>49</b>



# List of Figures

2.1	The instantaneous power $p(t)$ entering a circuit. . . . .	7
2.2	Real power dissipated in Resistive circuit . . . . .	9
2.3	Inductive circuit and Reactive Power . . . . .	10
2.4	Capacitive circuit and Reactive Power . . . . .	12
2.5	Single phase active and reactive power . . . . .	13
2.6	Power Triangle, Impedance Triangle. . . . .	14
2.7	Power triangle . . . . .	15
2.8	Typical Connections Inside Electronic Meters . . . . .	16
2.9	General Sensor depend on the Hall Effect . . . . .	18
2.10	Analog Front End for Current Inputs . . . . .	18
2.11	Current sensing hardware circuit . . . . .	19
2.12	Voltage Division Circuit . . . . .	20
2.13	Ideal transformer . . . . .	20
2.14	Analog Front End for Voltage Inputs . . . . .	21
2.15	Voltage sensing hardware circuit. . . . .	22
2.16	Input and output waveform . . . . .	22
3.1	1-Phase 2-Wire Star Connection detailed Block Diagram . . . . .	25
3.2	Photo of realized digital energy meter . . . . .	26
3.3	Pinout LPC2148 . . . . .	29
3.4	LA 55P Current Transducer . . . . .	30
3.5	Connection Diagram of TL081 . . . . .	31
3.6	16x2 LCD . . . . .	32

4.1	Input Current signal and Output Current Signal with offset . . . . .	41
4.2	Input Voltage signal and Output Voltage Signal with offset . . . . .	41
4.3	Input Voltage signal and Output Voltage sampled Signal. . . . .	42
4.4	Measurement setup for testing the sag and swell . . . . .	42
4.5	Measured RMS voltage before and after saging the voltage signal . .	43
4.6	Voltage wave form along with sag . . . . .	43

# List of Tables

3.1	LCD command . . . . .	34
4.1	Result of Current measurement in the laboratory with standard multimeter meter & prototype energy meter . . . . .	44
4.2	Result of Voltage measurement in the laboratory with standard multimeter meter & prototype energy meter . . . . .	45
4.3	Result of Energy measurement in the laboratory with standard calculation & prototype energy meter . . . . .	46

# Chapter 1

## Introduction

This application note describes a single-phase power/energy meter. The design measures active power/energy, potential, and current in a single-phase distribution environment. The heart of the meter is an ARM processor. All measurements are taken in the digital domain and measurement results are available in LCD.

Power meters are sometimes mentioned as energy meters and vice versa. According to terminology, (active) power is a measure of what is required (or consumed) in order to perform particular useful work. For example, a bulb with a 100W rating consumes 100 watts of real power in order to create light (and heat). Energy, per definition, is the measure of how much work has been required over a known period of time. In the light bulb example, enlighten the bulb on for an hour it will consume  $100\text{W} \times 3600\text{s} = 360000\text{Ws}$  (watt seconds) =  $100\text{Wh}$  (watt hours) =  $0.1\text{kWh}$  (kilowatt hours) of energy. The energy meter described in this application note can be referred to as an energy meter or a watt-hour meter. All measurement results can be calibrated in the digital domain, eliminating the need for any trimming components. The calibration event can be self-altering, and eliminate the time-consuming manual trimming required in traditional type electromechanical energy meters. The digital calibration is fast and efficient, minimizing the overall calculation time and cost. The brain of the meter is the software firmware code, which is provided open source. In spite of it includes all the functionality required for a single-phase meter,

it can be alter and updated at any time,even in the working mode. The software code is entirely written in C, which makes alteration easy.

## 1.1 Objective

The main aim of this intended project is to implement and construct a digital energy meter for domestic appliances. This energy meter will measure the electrical energy digitally, so user can easily identify how much energy they used at one time.

## 1.2 Scope of Project

Since the energy meter can calculate or determine the energy consumption of household appliances, the data can be used for the following studies:

- Calculate the average electrical energy consumption of selected appliances used in residential sector.
- Examine of the impact of energy efficiency labelling of domestic appliance.
- Forecast of future energy desire in residential sector based on end-use modelling techniques.
- Implementation of special website/programmers that can teach and promote efficient and wise use of energy.

## 1.3 Purpose and Description of Project

The *LPC2148* device is the latest system-on-chip (SOC), which belongs to the ARM generation of devices. This generation of devices belongs to the powerful 32-bit ARM platform bringing in a lot of new features and flexibility to support robust single, two and 3-phase metrology solutions. This thesis however, discusses

the implementation of 1-phase solution only. These devices find their application in energy calculation and have the necessary architecture to support them.

Furthermore, for large scale manufacturing, the costs can become lower than those of the electromechanical meters currently in production. This device presents a totally electronic single phase energy meter for residential use, based on ARM processor. A four digit display is used to show the consumed power. A prototype has been implemented to adequate measurement up to 5A load current from a 230V (phase to neutral) voltage. Higher current capacity can be easily obtained by simply replacing the shunt resistor. And, by changing the transformer tap & voltage divider ratio, and it can be easily manipulated for use in a 220 V supply.

The LPC2148 has a powerful 60 MHz CPU with ARM architecture. The analog front end consists of up to two channel of 10-bit analog-to-digital converters (ADC) based on a successive approximation architecture that supports differential inputs, with conversion time 2.44 micro second per channel. The ADCs operate independently and are capable to output 10-bit result. They can be grouped together for simultaneous sampling of voltage and currents on the same trigger. A 32-bit x 32-bit hardware on this chip can be used to further accelerate math intensive operations during energy calculation. The software supports calculation of various parameters for single phase energy calculation. The key parameters measured during energy measurements are: RMS current and voltage, energies. Alternatively, the design is ease to fits more computerized applications with features such as remote reading , demand recording, multiple tariffs, checking, and other.

## 1.4 Literature Review

In [1], the development of an Energy Meter (EM) this paper help to visualize the setup .It presents a single phase electrical energymeter based on a microcontroller from Microchip TechnologyInc. PIC family.This paper has demonstrated the possibility of calculating the electrical energy consumption with a microcontroller

based electronic meter, as an alternative to the conventional electromechanical meters.

The developed platform consists of two notable components to measure different kinds of the power consumption, voltage and current [2]. The power quantities are sensed and transformed in low level signals using the step down transformer and current transducer.

Voltage and current sensing circuit uses TL-081 [3] op-amp and LA-55P [4] component to make both the voltage and current signal measurable.

The TL-081 JFET-input operational amplifier family is designed to offer a wider selection than any previously developed operational amplifier family. This devices feature high slew rates, low input offset-voltage temperature coefficient and low input bias and offset input currents.

The Current Transducer LA-55P is used for the electronic measurement of currents: DC, AC, pulsed, with galvanic isolation between the primary circuit (high power) and the secondary circuit (electronic circuit).

In [5], an AC Meter development for AC Energy Monitors is described which has four main sections: signal filtering, Energy Metering and processing, power supply.

In [6] an electronic system is described to measure the real, imaginary and apparent energies delivered to a load of an AC circuits. The proposed system is directly connected to a Personal Computer for monitoring the power consumption.

In [7], Explained the design and implementation of Energy Meter, and the interface between a processor, sensing circuit and display can be categorized into two main distinctive portions. The first portion consists of the interface between processor and current/voltage sensing circuit. The second portion comprises the interface between the 16 x 2LCD and the processor; the interfaces in the first portion and second portion are both using the standard cables.

## **1.5 Contributions**

In most of the reviewed related literatures for sensing the voltage and current signal, Energy Meter Sensors are employing. Accordingly in order to control the measured data, calculating and then display, aprocessor should be operated. Data transmission will be possible through a specific device with unique properties.

In this thesis, all related calculation and transmission of the measured data via ADC port to a serial adaptor is done with only ARM Processor.

The objective of this intended project is to implement a digital Energy Meter using ARM processor(LPC2148), measure rms voltage, rms current, consumed energy and display to LCD. LPC2148 is the processor used in this thesis which can measured data through ADC.

The desired Energy Meter (EM) is successfully implemented based on ARM processor(LPC2148).



## Chapter 2

# MEASUREMENT OF ENERGY RELATED QUANTITIES

### 2.1 General Theory and Principles

#### 2.1.1 Real Power

For time varying voltages and currents, the power transfer to a load is also time varying. This time varying power is referred to as instantaneous consumed power. The real power is the average value of the instantaneous consumed power. The Mean Power rely on the rms value of load voltage and load current and the phase angle between them

$$P = \frac{1}{2}V_m I_m \cos(\theta_v - \theta_i) = V_{rms} I_{rms} \cos(\theta_v - \theta_i) \quad (2.1)$$

The real power (P), in watts, dissipated in an AC R-L, R-C, R-L-C circuit is dissipated in the resistance only for AC sinusoidal current and voltage,

$$P = I^2 R \quad (2.2)$$

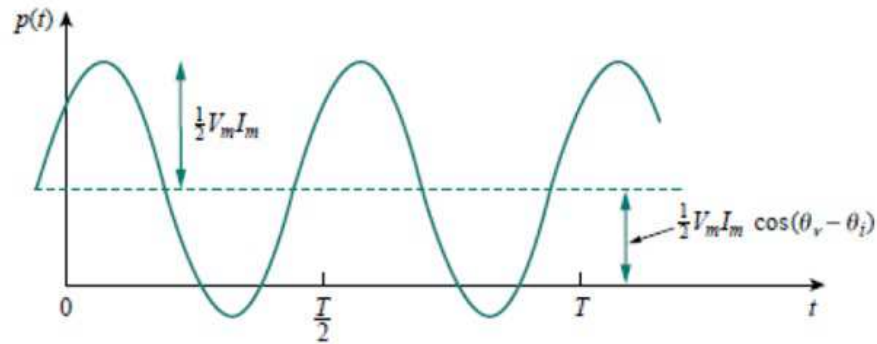

Figure 2.1: The instantaneous power  $p(t)$  entering a circuit.

### 2.1.2 Apparent Power

Apparent power is the combination of reactive power and true power, and it is the multiplication of a circuit's voltage and current, without regards to phase angle. Apparent power is calculated in the unit of Volt-Amps (VA) and is symbolized by the capital letter S.

The Apparent Power (S), in volt amperes (VA), is the product of the rms value of voltage and current.

$$S = \frac{1}{2} V_m I_m = V_{rms} I_{rms} \quad (2.3)$$

### 2.1.3 Power Factor

The Power Factor (pf) is the cosine of the phase difference between voltage and current. Power factor can also be found by dividing real power (P) by apparent power (S); so we have:

$$P.F = \frac{P}{S} = \cos(\theta_v - \theta_i) \quad (2.4)$$

$$P = \text{ApparentPower} \times \text{PowerFactor} = S \times P.F \quad (2.5)$$

### 2.1.4 Reactive Power

Explanation for reactive power says that, In an Alternative Current circuit voltage and current go rise and fall at the same period, only Active power is transmitted in circuit and when there is a time shift between voltage and current both active and reactive power are transmitted. But, when calculated the average in time, the average real power be found causing a net flow of energy from one section to another section, whereas average reactive power is null, regardless of the network or state of the system. In the instance of reactive power(imaginary power), the amount of energy passing in one direction is been equal to the amount of energy passing in the opposite direction (or different parts -capacitors, inductors, etc- of a network, exchange the reactive power). It producing a result that reactive power is neither produced nor consumed.

But, in reality we calculated reactive power losses, introduce so many equipment's for imaginary power compensation to reduce electricity consumption and cost.

The Reactive Power (Q), in volt amperes reactive (VAR), is the power which toggle between the supply and the reactance of the load and can be calculated from following equation;

$$Q = V_{rms}I_{rms} \sin(\theta_v - \theta_i) \quad (2.6)$$

It show that the Reactive Power is imaginary part of the Complex Power S.

$$S = P + jQ = Re \{S\} + j Im \{S\} \quad (2.7)$$

$$S = I_{rms}^2 Z = I_{rms}^2 (R + jX) = P + jQ \quad (2.8)$$

where

$$P = V_{rms}I_{rms} \cos(\theta_v - \theta_i) = Re \{S\} = I_{rms}^2 R \quad (2.9)$$

$$Q = V_{rms}I_{rms} \sin(\theta_v - \theta_i) = Im \{S\} = I_{rms}^2 X \quad (2.10)$$

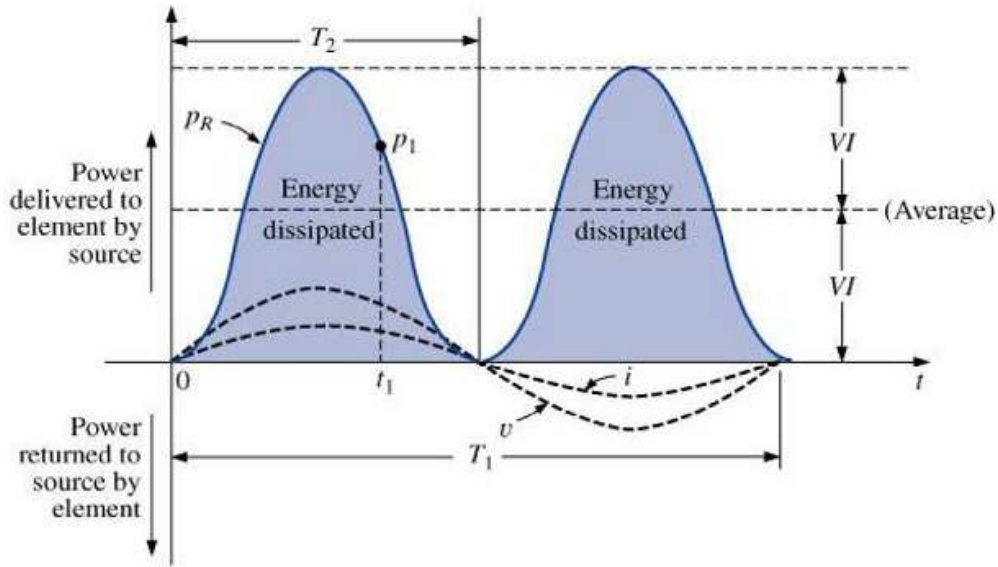

Figure 2.2: Real power dissipated in Resistive circuit

Therefore the equations below can be written as:

$$V(t) = V_m \sin(\omega t - \theta) \quad (2.11)$$

$$I(t) = I_m \sin(\omega t) \quad (2.12)$$

The instantaneous power is given by

$$P(t) = V_m I_m \sin(\omega t) \sin(\omega t - \theta) = \frac{1}{2} \times V_m I_m \times 2 \times \sin(\omega t) \sin(\omega t - \theta) \quad (2.13)$$

$$P(t) = \frac{1}{2} V_m I_m [\{\cos(\omega t) - \cos(\omega t - \theta) + \sin(\omega t) - \sin(\omega t - \theta)\} \\ - \{\cos(\omega t) - \cos(\omega t - \theta) - \sin(\omega t) - \sin(\omega t - \theta)\}] \quad (2.14)$$

$$P(t) = \frac{1}{2} V_m I_m [\cos \{ \omega t - (\omega t - \theta) \} - \cos \{ \omega t + (\omega t - \theta) \}] \quad (2.15)$$

$$P(t) = \frac{1}{2} V_m I_m [\cos \theta - \cos(2\omega t - \theta)] \quad (2.16)$$

$$p_R(t) = V(t) \times I(t) = V_{rms} I_{rms} \cos(2\omega t) \quad (2.17)$$

Since the phase angle between resistive current and voltage is null, the circuit has neither a lagging nor a leading power factor; therefore the load is Resistive and draws only active power.

From the above equation 2.17 it is clear that whatever may be the value of  $\cos 2\omega t$  can not be greater than one hence the value of  $P$  can not be negative value. The value of  $P$  is always positive regardless of the instantaneous direction of voltage  $v$  and current  $i$ , that define the energy is flowing in its conventional direction it means from source to load and  $P$  is given the rate of energy consumption by the load and this is called **active power**. As this power is absorbed due to resistive effect of an electrical circuit hence it is also called **resistive power**.

For a purely inductive circuit,  $v$  leads  $i$  by  $90^\circ$  as shown in Figure

$$\theta = 90^\circ(\text{inductive})$$

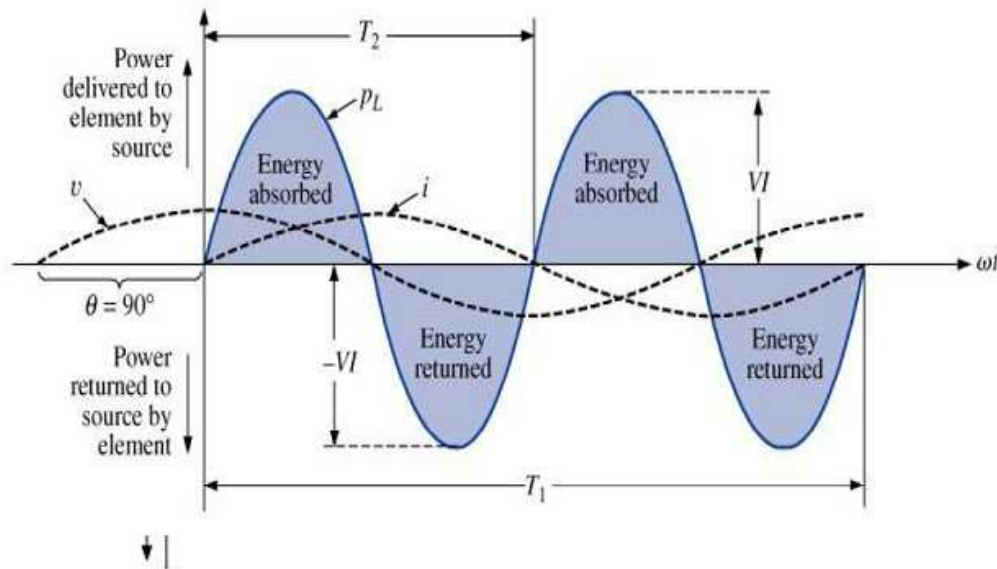

Figure 2.3: Inductive circuit and Reactive Power

The power absorbed or deliver by the inductor can be found as below:

$$P_L(t) = \frac{1}{2}V_m I_m [\cos \theta - \cos(2\omega t - \theta)] \quad (2.18)$$

Put  $\theta = +90^\circ$  (inductive)

$$P_L(t) = \frac{1}{2}V_m I_m [0 - \cos(2\omega t - 90^\circ)] \quad (2.19)$$

$$P_L(t) = \frac{1}{2}V_m I_m \sin(2\omega t) \quad (2.20)$$

$$P_L(t) = V_{rms} I_{rms} \sin(2\omega t) \quad (2.21)$$

The net flow of power to the pure (ideal) inductor is zero over a full cycle, and no energy loss is observed in the transaction.

In the above expression, it is found that the power is flowing in alternative directions. From  $0^\circ$  to  $90^\circ$  it will have positive half cycle, from  $90^\circ$  to  $180^\circ$  it will have negative half cycle, from  $180^\circ$  to  $270^\circ$  it will have again positive half cycle and from  $270^\circ$  to  $360^\circ$ , it will have again negative half cycle. Therefore this power is alternating in nature with a frequency, twice of supply frequency. As the power is flowing in alternating direction i.e. from load to source in one half cycle and from source to load in next half cycle the average value of this power is vanished. Therefore this power does not do any efficient work. This power is known as reactive power. As the above illustrate reactive power expression is related to fully inductive circuit, this reactive power is also called **inductive power**.

For a purely capacitive circuit,  $i$  leads  $v$  by  $90^\circ$  as illustrated in figure.

$$\theta = -90^\circ (\text{capacitive})$$

The power absorbed or delivered by the capacitor can be found as below:

$$P_C(t) = \frac{1}{2}V_m I_m [\cos \theta - \cos(2\omega t - \theta)] \quad (2.22)$$

$$\text{Put } \theta = -90^\circ$$

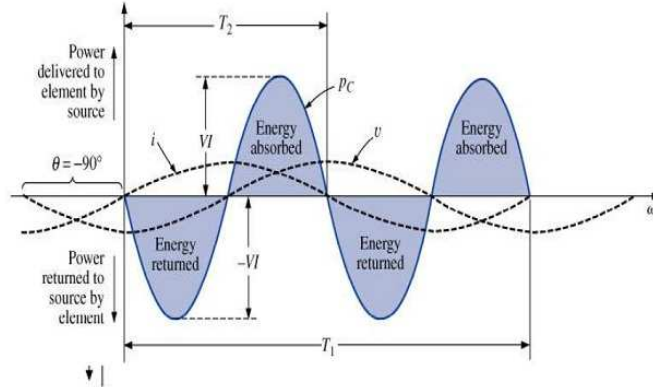

Figure 2.4: Capacitive circuit and Reactive Power

$$P_C(t) = \frac{1}{2}V_m I_m [0 - \cos(2\omega t - 90^\circ)] \quad (2.23)$$

$$P_C(t) = -\frac{1}{2}V_m I_m \sin(2\omega t) \quad (2.24)$$

$$P_C(t) = -V_{rms} I_{rms} \sin(2\omega t) \quad (2.25)$$

Resemble to the previous case, it is apparent that the net flow of power to the pure(ideal) capacitor is zero over a total cycle, and null energy loss is observed in the transaction as well.

Hence in the expression of **capacitive power**, it is also indicate that the power is flowing in alternative directions. From  $0^\circ$  to  $90^\circ$  it will have negative half cycle, from  $90^\circ$  to  $180^\circ$  it will have positive half cycle, from  $180^\circ$  to  $270^\circ$  it will have again negative half cycle and from  $270^\circ$  to  $360^\circ$  it will have again positive half cycle. So this capacitive power is also alternating in nature with a frequency, twice of supply frequency. Therefore, as inductive power and the **capacitive power** does not do any efficient work. This power is also a reactive power.

The consumed power equation can be re-written as:

$$P(t) = \frac{1}{2}V_m I_m [\cos \theta - \cos(2\omega t - \theta)] \quad (2.26)$$

$$P(t) = \frac{1}{2}V_m I_m [\cos \theta - \cos 2\omega t \cos \theta - \sin 2\omega t \sin \theta] \quad (2.27)$$

This above expression has two part of consonant; first one is  $\frac{1}{2}V_m I_m \cos \theta (1 - \cos 2wt)$  which never goes negative as because value of  $(1 - \cos 2wt)$  always greater or equal to zero but can not equal to negative value.

This portion of the single phase consumed power equation represents the expression of reactive power which is also known as true power or real power. The mean of this power will recognize have some non zero value means the power physically does some efficient work and that is why this power is also called real power or sometimes it is denoted as true power.

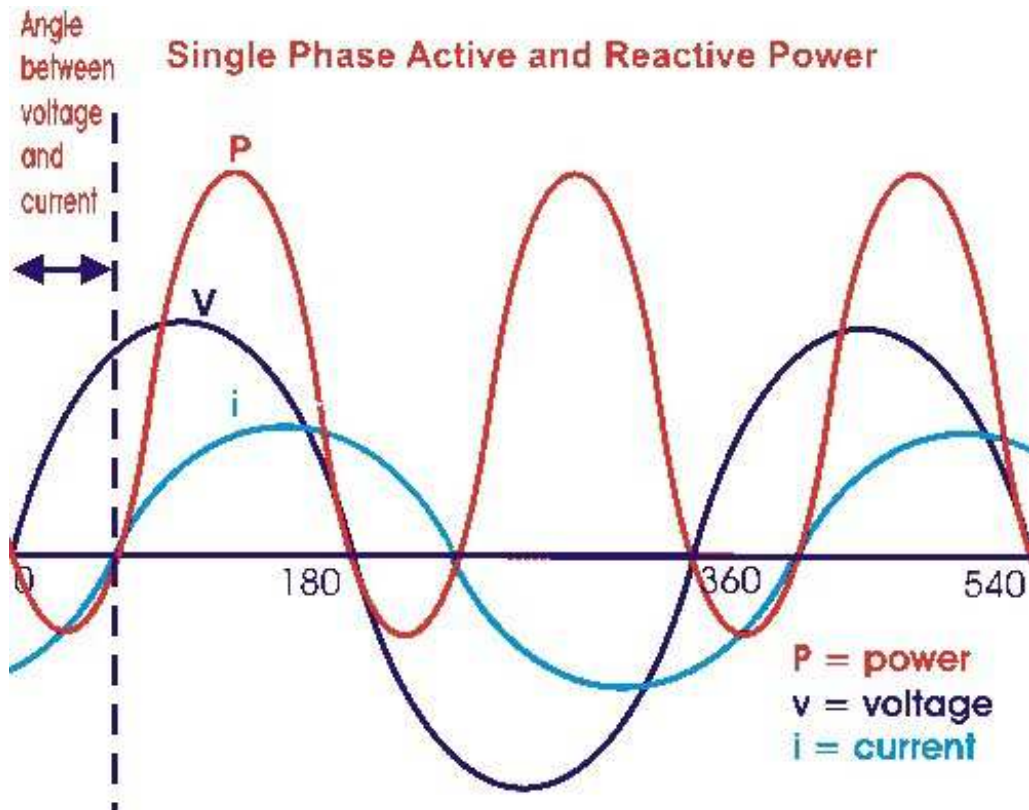

Figure 2.5: Single phase active and reactive power

Second term is  $\frac{1}{2} \sin \theta \sin 2wt$  which will have negative and positive cycles. Hence average of this component is vanished. This consonant is known as reactive component as it travels forth and back on the line without doing any efficient work.



Both **active power** and **reactive power** have equal amount of watts but to emphasize the fact that reactive component represents a non-active power, and it is calculated in terms of volt-amperes reactive or in short VAR.

### 2.1.5 Power and Impedance triangle

It is possible to show the relation between  $S$ ,  $P$  and  $Q$  in the form of a triangle, and known as the power triangle as shown in Figure (a). A similar relation between  $Z$ ,  $X$  and  $R$  can be given by the Impedance triangle as shown in Figure (b).

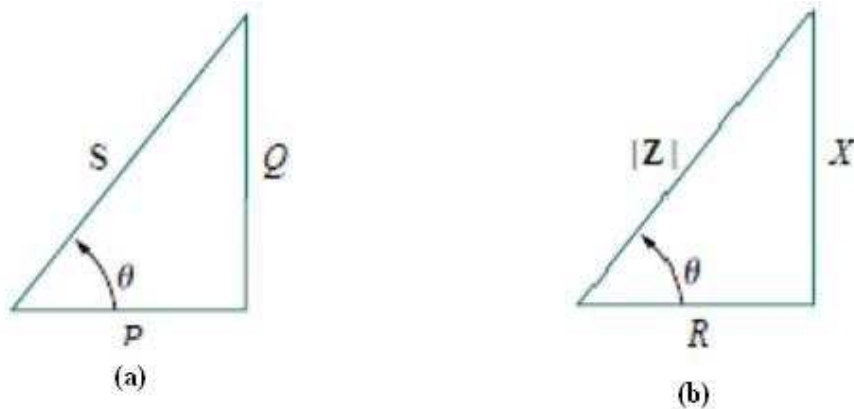

Figure 2.6: Power Triangle, Impedance Triangle.

If  $S$  exist in the first quadrant; the reactive power is positive; which means that the circuit has a lagging power factor and the load is inductive, and if  $S$  is in the fourth quadrant the power is reactive; which means that the load is capacitive and the circuit has a leading power factor, as illustrated in Figure.

## 2.2 Operational Considerations

As per the general theory and principles of the Power calculation; voltage and current is the capital part of the operation therefore measurement of the current and voltage is the prime requirement.

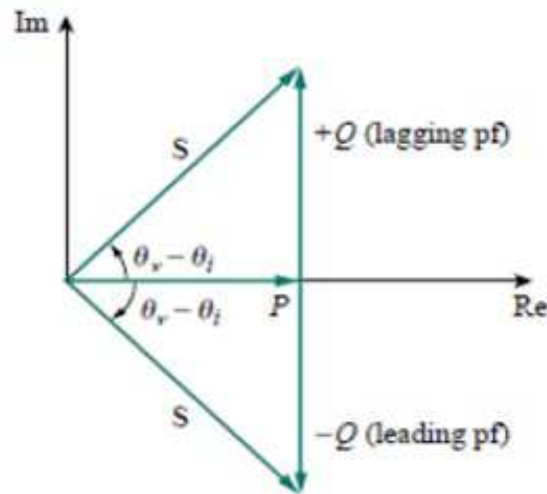

Figure 2.7: Power triangle

After calculating the values of the current and voltage; calculation of the all other energy related quantities is possible.

LPC2148, with two analog to digital (A/D) inputs, which is used for computing the current and voltage values; is preferred due to the ease in programming and the convenience of display data.

The general block diagram of Typical Connections inside Electronic Meters is illustrated in Figure 2.8.

In general, all the sensors used for energy meter; work based on two types of signal processing, namely analog and digital. This signal processing uses multiplication and averaging for the finding of the information required by an energy meter.

In preceding portions in this chapter all the methods used in this thesis are explained and in chapter 3 all used components regarding described methods are clarified.

This section explain various part that constitute the hardware for the design of a working 1-phase energy meter using the LPC2148. The LPC2148 analog front end that consists of the ADC is differential and requires that the input voltages at the pins do not exceed 3.3 volt . In order to meet this requirement, the current and

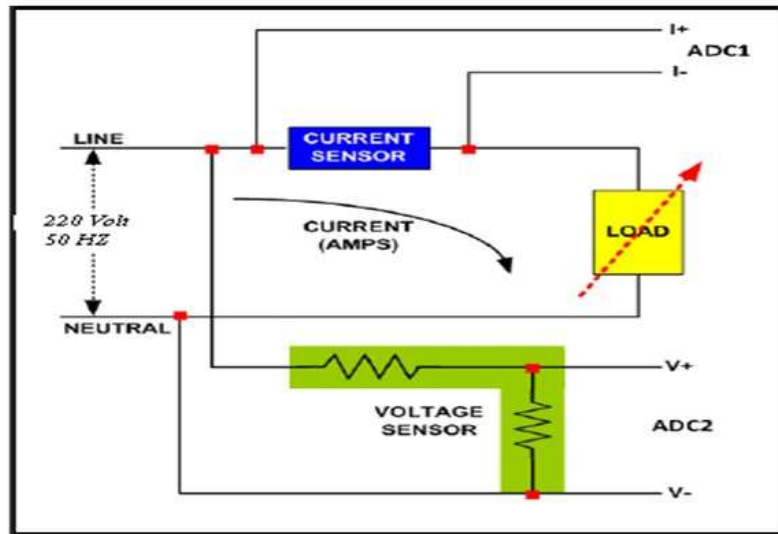

Figure 2.8: Typical Connections Inside Electronic Meters

voltage inputs need to be step up and step down respectively. In addition, the ADC does not allow a negative voltage, therefore, AC signals from mains cannot be directly interfaced and need level shifters. This subsection describes the analog front end used for current and voltage channels.

### 2.2.1 Current Sensing

Current Sensing however [1][16], poses much more difficult problems due to the rich harmonic content in the current waveform. Current transducer sensors not only require a much wider measurement dynamic range, but also necessary to handling of a much wider frequency range.

Considering merits and demerits, selection of which type of methods to be used for sensing the current is challenging, so the chosen appropriate possible solution is to employ the Hall Effect Sensor.

### 2.2.2 Hall Effect

Hall Effect is a phenomenon through which a conductor carrying an electric current(I) perpendicular to an applied magnetic field(B) develops a voltage gradient which make 90 angles to both the current and the magnetic field.

### 2.2.3 Hall Effect Sensor

The Hall Effect [2] is an ideal sensing technology; in terms of measurement especially at high frequency. The Hall element is build from a thin sheet of conductive material along with output connections perpendicular to the direction of current flow in conductive material. When influence to a magnetic field, it generate an output voltage proportional to the magnetic field strength applied. The voltage output is minor ( $\mu\text{V}$ ) and needs additional electronics to achieve useful voltage levels to do proper calculation. When the Hall element is merge with the associated electronics, it create a Hall Effect sensor.

General Sensor depend on the Hall Effect is shown in the Figure 2.9.

### 2.2.4 Current Inputs

Figure 2.10 shows the analog front end for the current inputs, which is flow through load. The current through load is measure by current transducer LA 55P. The current transducer is connected in series with load, it wounded with same wire which is connected to series. The transducer senses the current which is flow through the wounded wire and generates the current which is flow through the resistance R. And we are getting the voltage corresponding to the current which is flow through load.

The sensing voltage is low in amplitude and difficult to measure then it is passes through amplifier. The amplification factor is depend upon values of R1 and R2, and step up the voltage below 1 volt peak to peak. Output consist both positive and negative cycle but processor ADC respond or measure only positive values, it require level shifter to add a DC offset and pass to precision rectifier, It prevents

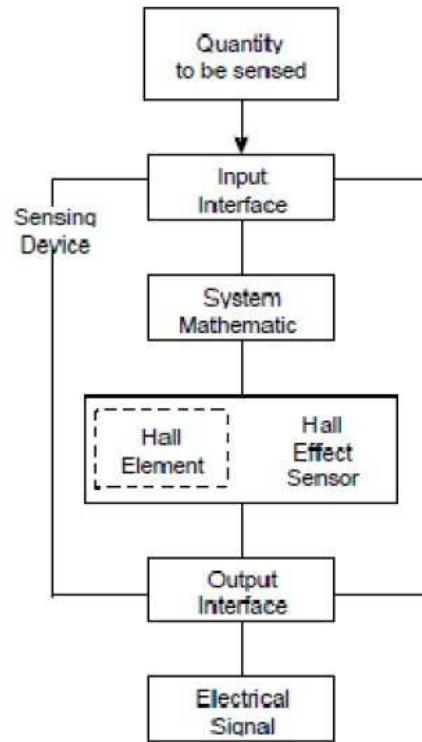

Figure 2.9: General Sensor depend on the Hall Effect

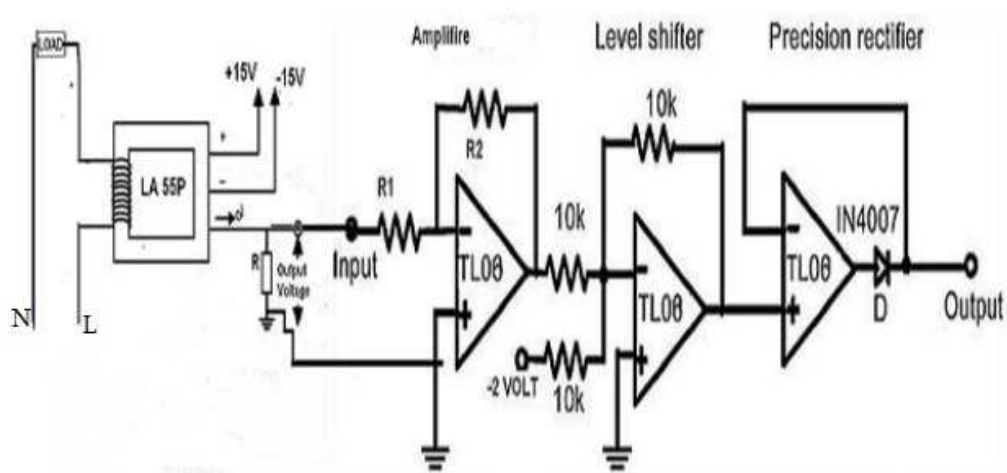

Figure 2.10: Analog Front End for Current Inputs

any excursion of negative voltage.

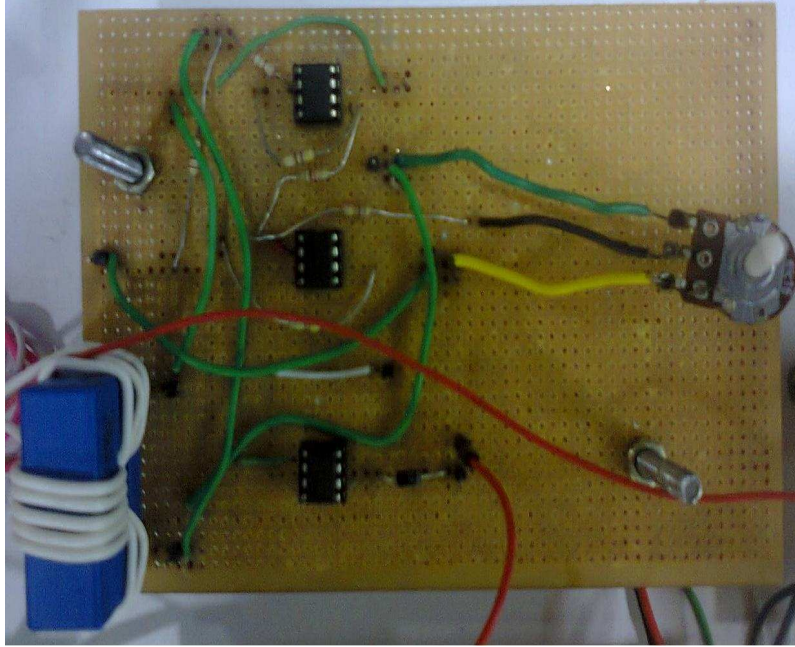

Figure 2.11: Current sensing hardware circuit

### 2.2.5 Voltage Sensing

Voltage sensing [2][16] is usually obtained by using either the voltage division method or a step down voltage transformer. Decision making about which method should be used, is related to the work necessities. Above two mentioned approaches are used in this project.

### 2.2.6 Voltage Division

Voltage Division is the most prefer way to divide down the line voltage based on Ohm's law. Relationship between input voltage  $V_{in}$  and Output voltage  $V_{out}$  is as below.

$$V_{out} = V_{in} \times \frac{R_1}{R_1 + R_2} \quad (2.28)$$

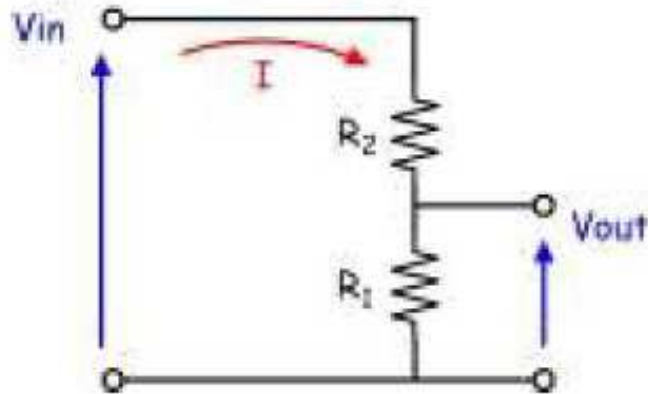

Figure 2.12: Voltage Division Circuit

### 2.2.7 Voltage Transformer

Voltage transformer are used to step down is an electromagnetic device which consists of two or more coils wound on a magnetic core and changes the voltage level in a circuit, under fixed frequency.

Consider an ideal transformer as shown in Figure 2.13.

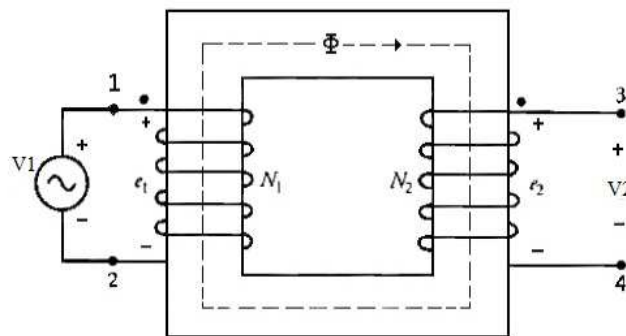

Figure 2.13: Ideal transformer

The ratio of secondary and primary voltage can be obtained from equation as:

$$\frac{V_1}{V_2} = \frac{N_1}{N_2} = \frac{I_2}{I_1} \quad (2.29)$$

As it is mentioned, ARM processor [LPC2148] is the device, which is been used in this achievement and the maximum voltage can be sensed by microcontroller is 3.3 V DC.

### 2.2.8 Voltage Inputs

The analog front-end for voltage inputs is a little different from the analog front end for the current inputs. The voltage from the mains is usually 230 V and needs to be brought down to a measurable range.

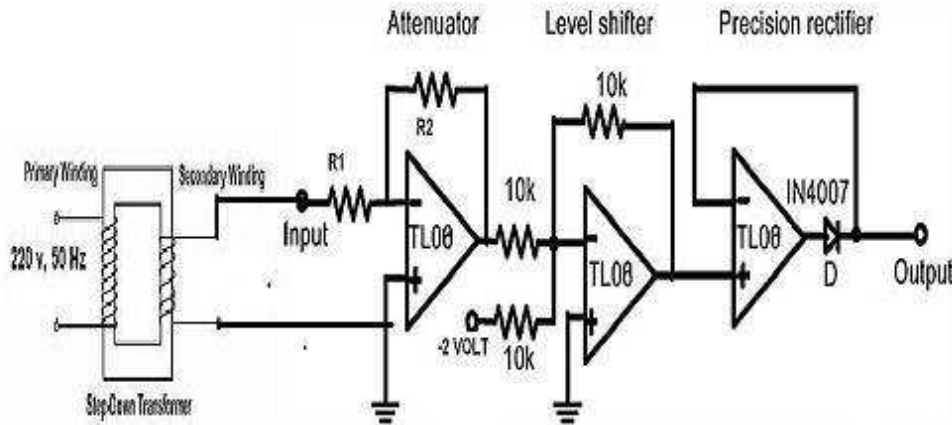

Figure 2.14: Analog Front End for Voltage Inputs

Figure 2.14 shows the analog front end for the voltage inputs for a mains voltage of 220 V. The voltage is brought down to approximately below 2.33 V RMS, which is 3.33V peak and fed to the input, adhering to the LPC2148 analog limitation. A common ground voltage can be connected to the GROUND input of the ADC.

In that figure 2.14, 220 volt is step down to 24 volt peak to peak through step down transformer. The output of transformer is not measurable; to make it measurable it passes through attenuator to step down the voltage below 1 volt peak to peak. Output consist both positive and negative cycle but processor ADC respond or measure only positive values, it require level shifter to add a DC offset



and pass to precision rectifier, It prevents any excursion of negative voltage.

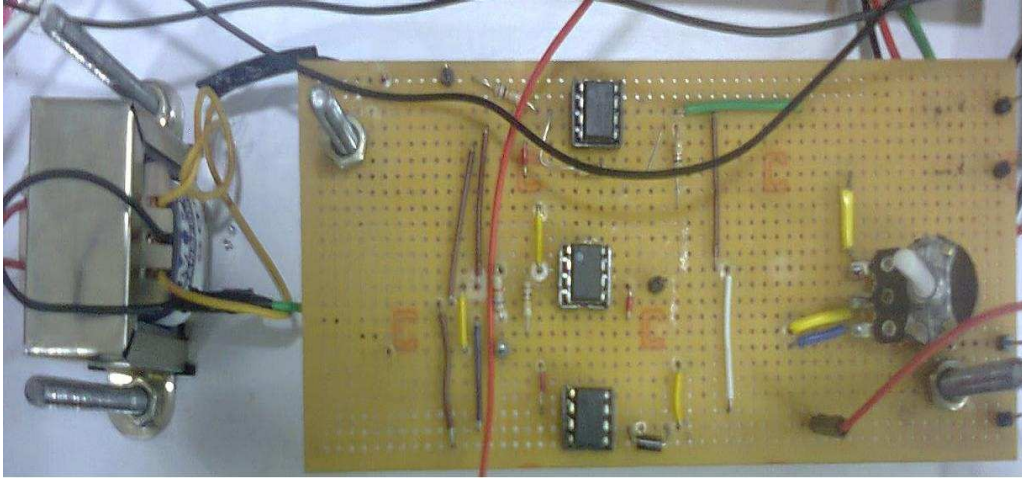

Figure 2.15: Voltage sensing hardware circuit.

Figure shows the input and output waveform of the analog front end for voltage inputs. Input waveform has higher amplitude as compare to output waveform and also the output waveform has a DC offset which make all the waveform values positive as compare to input waveform.

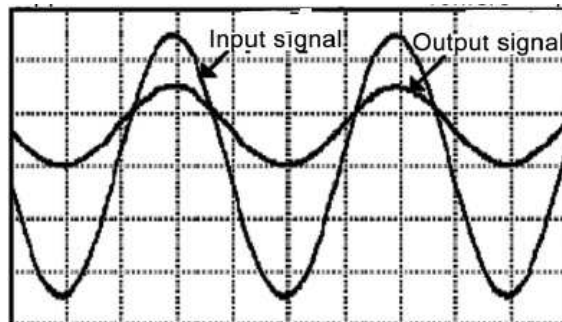

Figure 2.16: Input and output waveform

### 2.2.9 Data Analysis and Display

After voltage and current measurement procedure [3], next step is data analysis and display. Samples are taken from ADC peripherals and passed through following

steps :

- **Offset Removal**

Both voltage and current sample has a offset DC value, to measure the accurate value of rms voltage and rms current offset removal is necessary.

- **Gathering samples**

After eliminating offset, accumulate 1000 sample in one second and calculate rms voltage, rms current, and consumed power on the basis of 1000 samples.

- **Display**

16x2 LCD display for showing the calculated data or rms voltage, current and energy, it is necessary.

Microsoft Visual Studio C is a programming language that is designed for building an application that run on the .NET Framework. C is simple, efficient, type-safe, and object-oriented.

## Chapter 3

# DESIGN OF MEASUREMENT SYSTEM AND DATA DISPLAY

### 3.1 General Design Procedure

As it is mentioned in 2.2.3 and 2.2.5 sections; [2][4][1] Current Transducer or Hall Effect Sensor are the elements that can be used for current sensing whereas Resistive Voltage Divider circuit and Voltage Transformer are utilized for voltage sensing. Two voltages are obtained as the current and voltage signals which is used for energy calculation.

The detailed Block Diagram of the desired digital energy meter is shown in figure 3.1 . The block diagram that shows the high-level interface used for a single-phase energy meter application using the LPC2148. Current sensors are connected to the current channels and a potential transformer is used for corresponding voltages. L and N show the line and neutral voltages.

This system is designed based on an ARM processor [LPC2148] which acts as a data acquisition processing and display system. A current and a voltage signal are connected to its analog inputs and converted into digital form. The LPC2148 can therefore calculate the rms values of measured signals together with the energy

consumed at the measurement terminals.

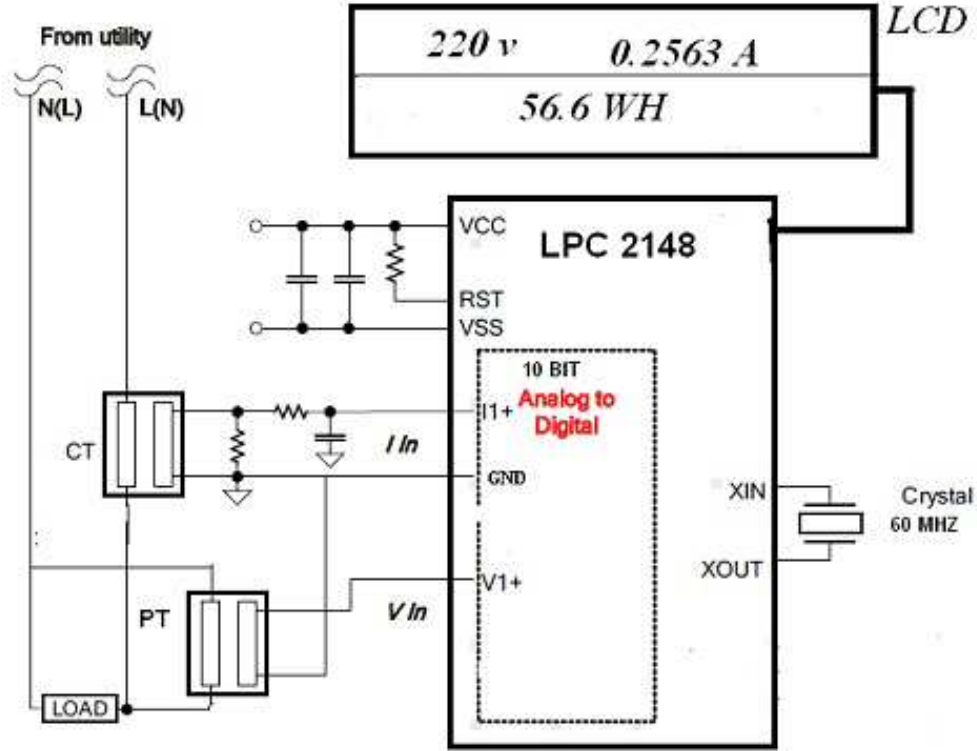

Figure 3.1: 1-Phase 2-Wire Star Connection detailed Block Diagram

In the last stage Data display is conducted using 16x2 LCD driver. It showing the calculated data or rms voltage, rms current and consumed energy by load.

### 3.2 Hardware Design

After explaining the common principles of the design procedure [4][6], the next step is to simulate the hardware using the multisim software; since not everything can be simulated through software, some results need to be acquired by relying on experiments.

The desired Energy Meter (EM) is successfully implemented based on ARM processor, which is shown in Figure.

The details for the main parts of Energy Meter are presented in the following sections.

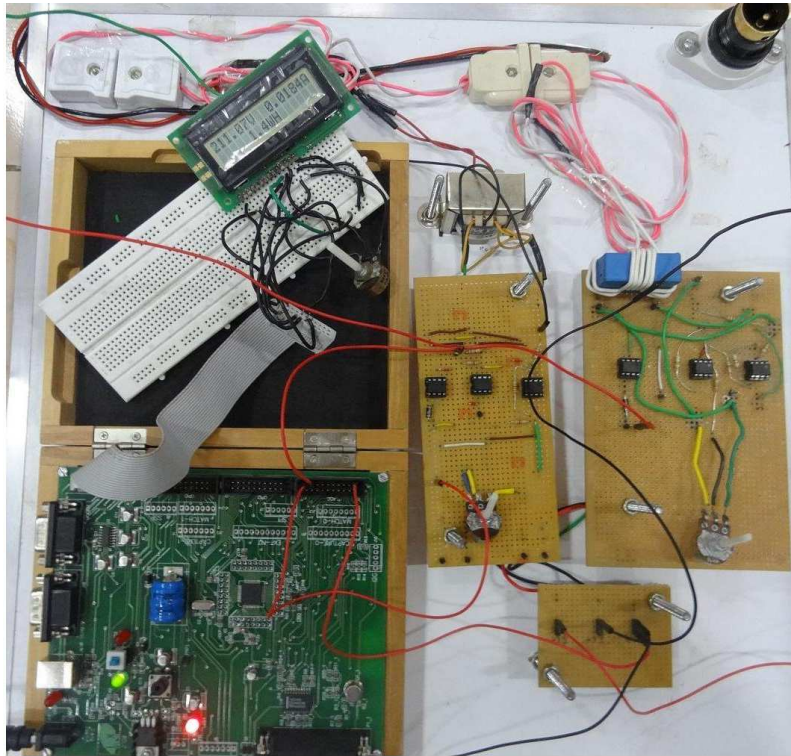

Figure 3.2: Photo of realized digital energy meter

### **3.2.1 ARM processor (LPC2148)**

The ARM (Advanced RISC Machine) is a 32-bit microcontroller created by a consortium of companies and manufactured in many different kind of versions. And it is widely used in modems, cell phones, cameras, personal audio, pagers, and many more embedded high end applications.

The LPC2148 is a low-power Complementary metal-oxide-semiconductor (CMOS) 32-bit microcontroller used the enhanced RISC architecture which is used as the main part of this project. Through executing powerful instructions in a single clock cycle, the LPC2148 achieves throughputs approaching 17 MIPS sustained 25 MHz permit the system designer, to optimize power consumption versus processing speed, operating Voltage range for this microcontroller is - 4.5V - 5.5V.

Generic RISC features:

- A huge number of general purpose registers along with the compiler technology to optimize register usage.
- A limited and ease instruction set.
- An emphasis on modify the instruction pipeline.
- Load and store architecture with ease addressing modes.

#### Features of LPC2148

- 16/32-bit ARM7TDMI-S microcontroller with in a tiny LQFP64 package.
- 32 kiloByte of on-chip SRAM and 512 kiloByte of on-chip Flash program memory. 128 bit wide interface/accelerator to enables high speed 60 MHz operation.
- In-System/In-Application Programming (ISP/IAP) through on-chip boot-loader software. Single Flash sector or full chip erase with in 400 millisecond and programming of 256 bytes in 1 millisecond.
- Embedded ICE and Embedded Trace user interfaces offer real-time debugging with the on-chip Real time Monitor software and high speed tracing of the instruction execution.
- Two eight input channel 10-bit Analog to Digital converters provide a total of up to 16 analog inputs channel, with conversion times as 2.44  $\mu$ s per channel.
- Single 10-bit Digital to Analog converter provides variable analog output.
- Two 32-bit counters/timers (with four compare and four capture channels each), Pulse Width Modulator unit (six outputs) and watchdog.
- Real-time clock equipped with an independent power and internal clock supply permitting extremely low value of power consumption in power save modes.

- Multiple serial interfaces including two Universal asynchronous receiver/transmitter (16C550), two Fast Inter-IC(I2C) (400 kbit/s), SPI and SSP with storing and variable data length capabilities.
- Vectored interrupt controller with superable priorities and vector addresses.
- Up to 47 of 5 V tolerant general purpose input/output pins in tiny LQFP64 package.
- level sensitive external interrupt(Up to nine edge) input pins available.
- 60 MHz maximum CPU clock is available from programmable on-chip Phase-Locked Loop (PLL) with a settling time of 100 microseconds.
- On-chip crystal oscillator with different operating range of 1 MHz to 30 MHz or with external oscillator vary from 1 MHz to 50MHz.
- Power saving modes include both Idle and Power-down.
- Individual enable/disable of the peripheral functions as well as the peripheral clock scaling down for procure power optimization.
- Processor wake-up from Power-down mode through external interrupt.
- Single power supply(5 volt) chip with Brown-Out Detection (BOD) and Power-On Reset (POR) circuits:
- CPU operating voltage range varies from 3.0 V to 3.6 V (3.3 V 10 %) with 5 V tolerant Input/Output pads.

Figure3.3 is shown the Pin out of LPC2148:

As it is illustrated in Port 0.28 and Port 0.30 is merge with AD0.1 and AD0.3 respectively serves as the analog inputs to the A/D converter so Pins 13 and 15 are used as inputs for the voltage and current values.

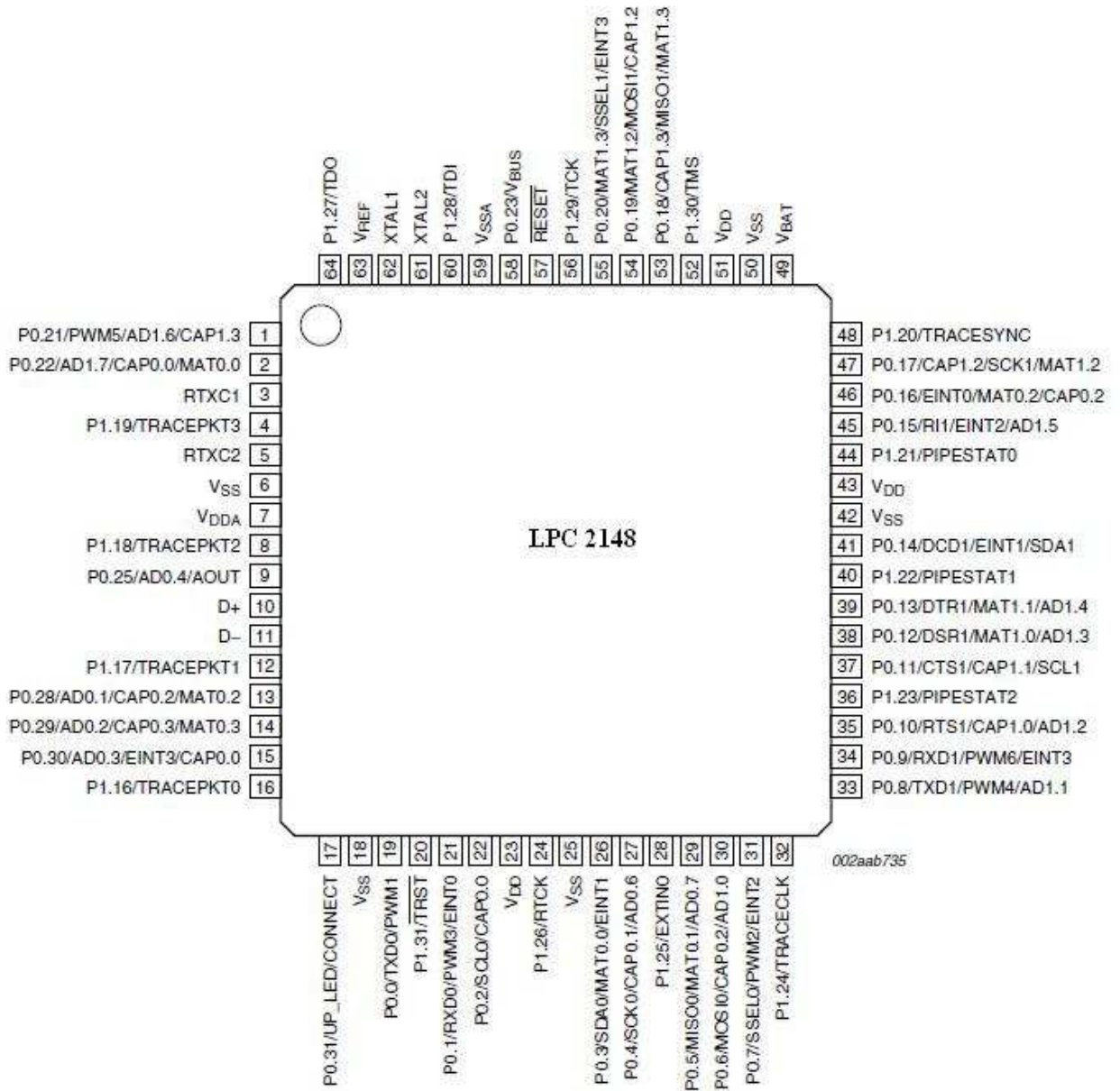

Figure 3.3: Pinout LPC2148

This ability of LPC2148 allows to use Port 0 pins as A/D converter and lets the users read the values which are required therefore these two inputs should be in the permissible range of at most 3.3 V for microcontroller.



### 3.2.2 Hall Effect Sensor

The Hall Effect Sensor; empoly in this project is the LA-55P [1] is the element which senses the required current with the methods that were subjected in the previous chapter and helps to get accurate results. The Hall Effect Sensor is also called the Current Transducer since it converts the current into voltage which can be applied directly to the LPC2148 analog input after amplification. LA-55P is the device used for the electronic measurement of current: Direct current,pulsed, Alternating Current, mixed with the galvanic isolation in between the primary circuit (high power) and the secondary circuit (electronic circuit).

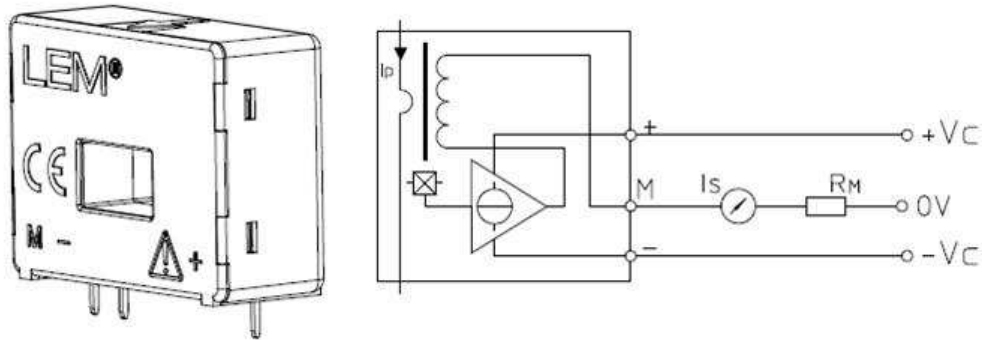

Figure 3.4: LA 55P Current Transducer

Features of this device are as below:

This Hall Effect Sensor with a galvanic isolation between primary and secondary circuit can be empoly for measurement purposes as this sensor has isolation voltage up to 2500V and consumes very low power. This LA 55P sensor may be used in AC variable speed drives, Uninterruptible Power Supplies (UPS), DC motor drives, Switched Mode Power Supplies (SMPS).

Advantages:

- Excellent accuracy
- Very good linearity
- Low temperature drift

- Optimized response time
- Wide frequency bandwidth
- No insertion losses
- Highly immunity to external interference
- Current overload capability.

### 3.2.3 TL081 Op Amp

The TL081 [5] series are general purpose operational amplifiers whose performance is improved according to requirements of industrial standards. The TL081 amplifiers offer many characteristic which make their application nearly foolproof: overload protection on the input and output side, no latch-up when the common mode range is exceeded, and the oscillations are prevented. Their performance is Best over a 0<sup>0</sup>C to +70<sup>0</sup>C temperature range. This amplifier is the most important part which is used as a attenuator, level shifter and precision rectifier, and the output of which is applied to the processor to enable the calculation of the different parameter related to current, voltage and energy meter.

Connection diagram of TL081 is as shown below:

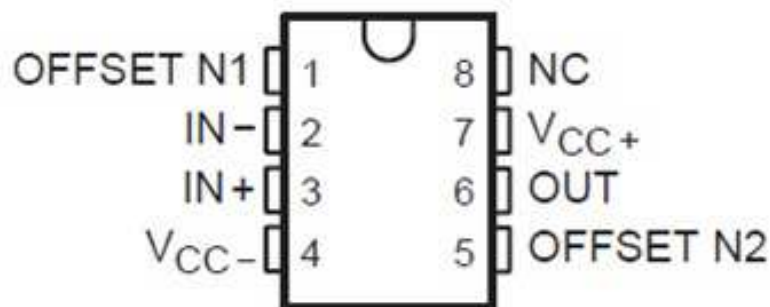

Figure 3.5: Connection Diagram of TL081

### 3.2.4 LCD

Liquid crystal display [6] or LCD as shown in Figure is one of the most used devices for alphanumeric output in processor-based circuits. Their advantages are their cost, reduced size and convenience of mounting the LCD directly on the circuit board. LCD is classified according to their interface into Parallel and serial. The Serial LCD requires less I/O resources but execute slower than their parallel counterparts and are considerably more costly. In this project, parallel-driven LCD devices based on the Hitachi HD44780 character-based controller, and which is by far the most popular controller for microcontroller-driven LCD.

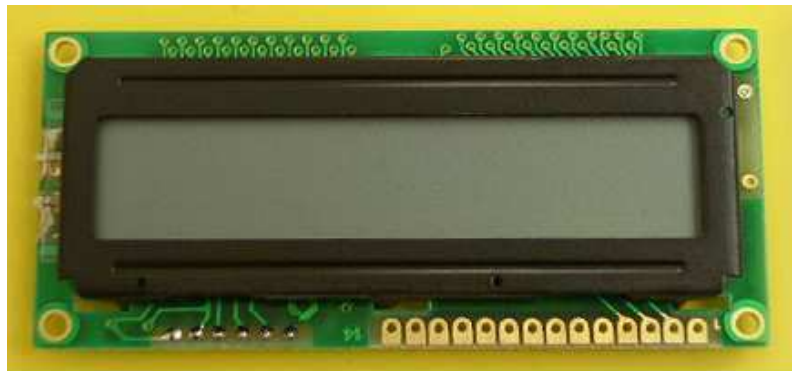

Figure 3.6: 16x2 LCD

The HD44780 is a dot-matrix liquid crystal display controller and driver. The device displays ASCII alphanumeric characters like as Japanese kana characters, and some symbols like in Figure 2.10. A single HD44780 can display up to two 28-character lines. An available extension driver makes possible addressing up to 80 characters. The HD44780U contains a 9,920 bit character-generator Read Only Memory that generate a total of 240 characters: 208 characters with a 58 dot resolution and 32 characters at a 510 dot resolution. The HD44780U device is capable of storing 64x8-bit character data in its character generator Read access Memory. This correlate to eight custom characters in 5x8-dot resolution or four characters in 5x10-dot resolution. The HD44780U controller is programmable to three different duty cycles: 1/8 for one line of 58 dots with cursor & 1/11 for one

line of 510 dots with cursor, & 1/16 for two lines of 58 dots with cursor.

The in built commands include homing the cursor, setting display characters to blink, clearing the display, turning the cursor on and off, turning the display on and off, reading and writing data to the character generator, shifting the cursor and the display right-to-left or left-to-right, and to display data ROM.

### **3.3 Software Development**

After testing and simulation of every single part, the operational program for processor is written under ARM-IDE in conformance with the designed circuit.

The implementation of software for the single-phase metrology is discussed in this section. The first subsection discusses the set up of various peripherals of the energy meter. Subsequently, the entire metrology software is described as two major processes: background process and foreground process.

#### **3.3.1 Peripherals Set Up**

The major peripherals are the ADC of LPC2148, clock system, timer, LCD, and so forth. The LPC2148 has two on-board analog-to-digital converters each of which provides 10-bits of accuracy with a conversion time of about  $2.44 \mu$  sec. Each converter has an 8-channel analog front end so that there are 16-channels of A/D available.

For a single phase system at least two ADC are necessary to independently measure one voltage and current. ADC 0.1 is used to measure the voltage samples and ADC 0.3 is used to measure the current sample. The sampling of voltage and current is completed by timer operation. Timer which has the clock frequency 1 MHz is used to make the sample frequency 1 KHz by generate a delay of 1 millisecond. The input signal frequency of voltage or current both have 50 Hz frequency and time period 20 millisecond. In one cycle through ADC processor is getting a 20 sample and in one seconds it getting a 1000 samples. On basis of one second or 1000 samples

Table 3.1: LCD command

Code(hex)	Command to LCD Instructin register
1	Clear display screen
2	Return home
4	Decrement cursor (shift cursor to left)
6	Increment cursor (shift cursor to right)
5	Shift display right
7	Shift display left
8	Display off, cursor off
A	Display off, cursor on
C	Display on, cursor off
E	Display on, cursor blinking
F	Display on, cursor blinking
10	Shift cursor position to left
14	Shift cursor position to right
18	Shift the complete display to the left
1C	Shift the complete display to the right
38	2 lines and 5x7 matrix
C0	Force cursor to beginning to second line
80	Force cursor to beginning to first line

LPC2148 measure the RMS voltage, RMS current and ENERGY consumed in one second by load.

After calculating the RMS voltage and current, energy it will display to LCD. This process is running continuously and update the value of RMS voltage ,RMS current and energy, and display in LCD.

### **3.3.2 The Foreground Process**

The foreground process [7][9][10][11] includes the initial set up of the LPC2148 hardware and software immediately after a device RESET. Figure shows the flowchart for this process.

The initialization routines process involves the set up of the analog to digital converter, clock system, general purpose input/output (GPIO) port pins, timer, LCD. During normal operation, the background process informs the foreground process every time a frame of data is available for processing. This data frame composed of accumulation of energy for 1 second. This is equal in value to accumulation of 50 or 60 cycles of measured data samples synchronized to the incoming voltage signal. In parallel, a data sample counter keeps track of how many samples have been accumulated over the frame period. This count value can vary as the software synchronizes with the incoming mains frequency. The data samples value set consist of processed current, voltage, active energy. All values are accumulated and further process to obtain the RMS and mean values.

**Flow Chart diagram for Foreground process**

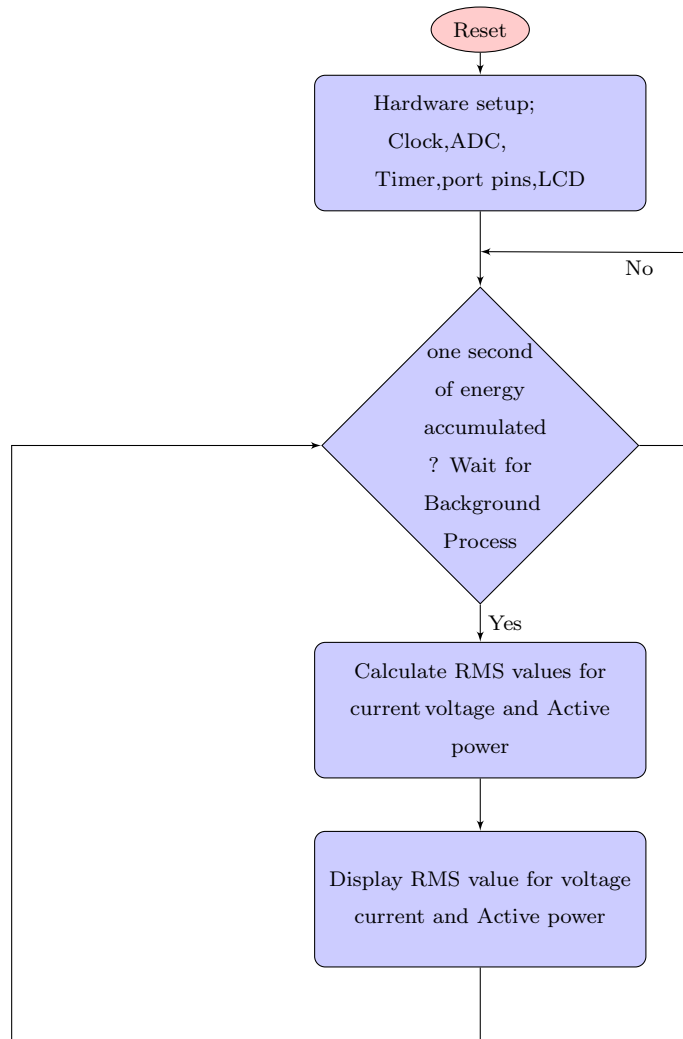

**3.3.3 The Formulae**

This section briefly explain the formulae used for the rms load current & rms load voltage and energy calculations.

**Voltage and Current**

As discussed in the above sections simultaneous voltage and current samples are obtained from two channel of A/D converters at a sampling rate of 1000 Hz. Track the number of data samples that are present in 1 second is kept and used to obtain

the Root Mean Square values for voltage and current for each phase.

$$V_{rms} = K_v \times \sqrt{\frac{\sum_{i=1}^{sample\ count} V_i^2(t)}{sample\ count}} \quad (3.1)$$

$$I_{rms} = K_I \times \sqrt{\frac{\sum_{i=1}^{sample\ count} I_i^2(t)}{sample\ count}} \quad (3.2)$$

Where

$V_{rms}$  = RMS value of voltage

$I_{rms}$  = RMS value of current

$V(i)$  = Voltage sample at a sample instant 'i'

$I(i)$  = Current sample at a sample instant 'i'

Sample count= Number of data samples in 1 second

$K_v$  = Scaling factor for voltage

$K_i$  = Scaling factor for current

**Power and Energy:** Consumer power and energy [8][13][14] are calculated for a frames worth of active energy samples. These samples are phase rectified and passed on to the foreground process which accumulate the number of samples (sample count) and use the formulae shown below to calculate total active powers.

$$P_{act} = K_P \times \frac{\sum_{i=1}^{sample\ count} V_i(t) \times I_i(t)}{sample\ count} \quad (3.3)$$

Where

$P_{act}$  = Actual power consumed by load

$K_p$  = Scaling factor for power

$V(i)$  = Voltage sample at a sample instant 'i'

$I(i)$  = Current sample at a sample instant 'i'

Sample count= Number of data samples in 1 second

The consumed energy is then measured based on the active power value for each frame:

$$P_{act1} = \frac{P_{act}}{3600} \quad (3.4)$$



Where

$P_{act1}$  = Actual power consumed by load in 1 second.

### **3.3.4 The Background Process**

The background process uses the timer as a trigger to collect voltage and current samples (two values in total). These samples values are further processed and accumulated in dedicated 32-bit registers. The background function deals mainly with timing critical events in software. Once sufficient samples (1 second worth) has been accumulated after then the foreground function is triggered to calculate the final values of rms voltage, rms current, power and energy. The background process is also completely responsible for energy calculation for each phase. Below the flow chart diagram of the background process is shown.

In background process analog to digital converter took the 1000 samples in one second of voltage and current. First eliminate the offset of both the voltage and current sample and then calculated the RMS value of voltage, RMS value of current, and Power consumed by load in one second. After processed calculation notify the foreground process.

The determined instantaneous voltage and current samples are used to generate the following information:

- Accumulated squared values of voltage and current for  $V_{RMS}$  and  $I_{RMS}$  calculations.
- Accumulated energy samples to measure Active Energy.

**Flow Chart diagram for Background process**

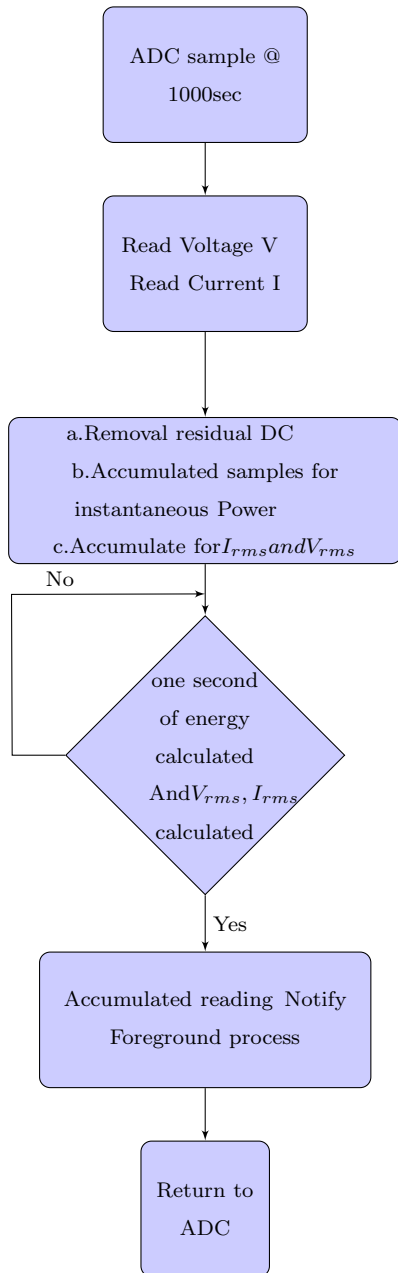

# Chapter 4

## EXPERIMENTAL RESULTS

Some measurements with the implemented Energy Meter are conducted regarding the accuracy of the system for evaluation process. The required performance of the prototype meter has been evaluated in the laboratory.

### 4.1 Testing Voltage and Current sensing Circuit

In order to see that voltage and current sensing circuit are correctly doing their duties, input signal and its related output is controlled by a digital real time oscilloscope.

Results are shown in the Figure 4.1 Input Current signal and Output Current Signal with offset Figure 4.2 Input Voltage signal and Output Voltage Signal with offset.

It is clearly observed on Figure 4.1,4.2 that the sinusoidal input signals is amplified for current sensing and attenuated for voltage sensing circuit, then both signals levels are shifted. The output of voltage and current sensing circuit has positive value in both cycle faithfully with almost no phase shift.

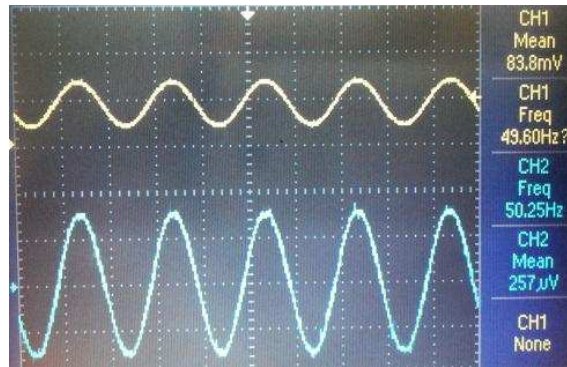

Figure 4.1: Input Current signal and Output Current Signal with offset

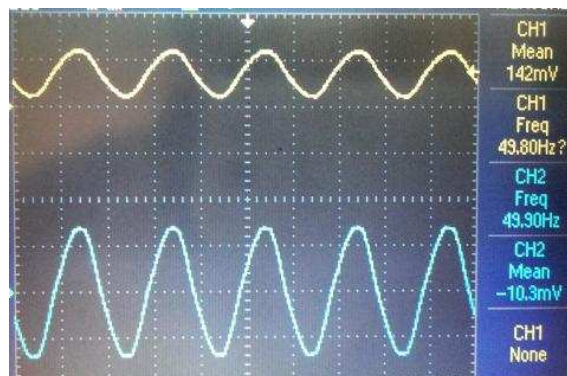

Figure 4.2: Input Voltage signal and Output Voltage Signal with offset

## 4.2 Testing for samples

In order to see that ADC of LPC2148 are correctly doing their duties, input signal and its related output is controlled by a digital real time oscilloscope.

Results are shown in the Figure 4.3 Input Voltage signal and Output Voltage sampled Signal.

It is clearly observed on figure 4.3 that the sinusoidal input signals are correctly sampled through ADC of LPC2148. Input is applied to the input port of ADC channel and then ADC digital output is passed to Digital to Analog converter. Analog output is traced, which is display in CRO as shown above.

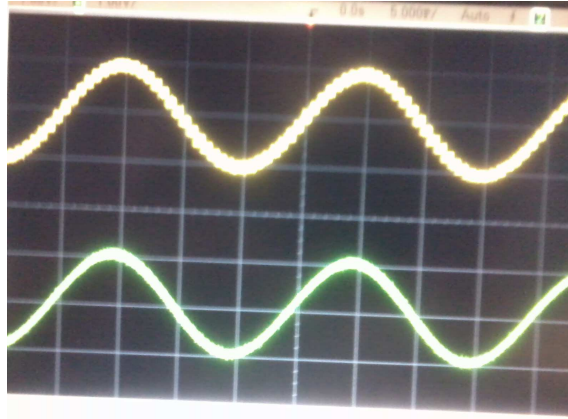

Figure 4.3: Input Voltage signal and Output Voltage sampled Signal.

### 4.3 Tests for sag of signal

The performance of the prototype meter is evaluated that it can measure the swell and sag in a time limitation. In common electric circuit it is occur frequently, by following test it showing the measuring ability.



Figure 4.4: Measurement setup for testing the sag and swell

Figure 4.4 shows the measurement setup for creating a swell and sag signal along

with energy meter to measure the change.

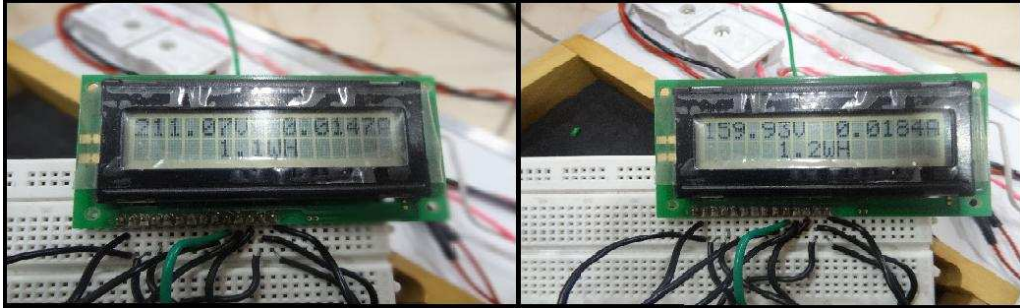

Figure 4.5: Measured RMS voltage before and after saging the voltage signal

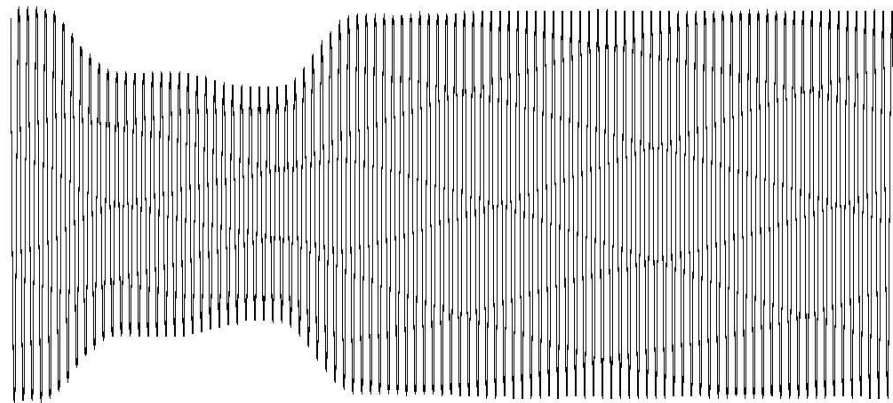

Figure 4.6: Voltage wave form along with sag

## 4.4 Tests on Current measurement

The performance of the prototype is evaluated by comparing the prototype reading with the standard meter. Table 4.1 shows true RMS current as measured by standard meter and proposed meter and relative (%) error.

Table 4.1: Result of Current measurement in the laboratory with standard multimeter meter & prototype energy meter

Number of measurement	Measured rms value of current (amp) (Standard meter)	Measured rms value of current (amp) (Prototype meter)	Relative Error (%)
1	0.2793	0.2799	-0.214823
2	0.2903	0.291	-0.24113
3	0.3016	0.302	-0.132626
4	0.3118	0.3125	-0.224503
5	0.3231	0.324	-0.278552
6	0.3324	0.3315	0.2707581
7	0.3427	0.3426	0.02918
8	0.3522	0.353	-0.227144
9	0.3619	0.361	0.2486875
10	0.3714	0.372	-0.161551
11	0.381	0.38	0.2624672
12	0.3906	0.3904	0.0512033

The measured values of current obtained from the readings of the sub standard meter are considered as standard and compared with proposed method values to check the accuracy of the metering system.

## 4.5 Tests on Voltage measurement

The performance of the prototype is evaluated by comparing the prototype reading with the standard meter. Table 4.2 shows true RMS voltage as measured by standard meter and proposed meter and relative (%) error.

The measured values of voltage obtained from the readings of the sub standard

Table 4.2: Result of Voltage measurement in the laboratory with standard multimeter meter & prototype energy meter

Number of measurement	Measured rms value of voltage (volt) (Standard meter)	Measured rms value of voltage (volt) (Prototype meter)	Relative Error (%)
1	130.45	130.56	-0.084323
2	140.1	140.35	-0.178444
3	150.4	150.14	0.1728723
4	160	159.93	0.04375
5	170.9	170.81	0.0526624
6	180.24	180.6	-0.199734
7	190.49	190.4	0.0472466
8	200.2	200.19	0.004995
9	210.1	209.98	0.0571157
10	220.17	219.77	0.1816778
11	230.1	229.8	0.1303781
12	240	239.6	0.1666667

meter are considered as standard and compared with proposed method values to check the accuracy of the metering system.

## 4.6 Tests on Consumed Energy measurement

The performance of the prototype is evaluated by comparing the prototype reading with the standard calculation. Table 4.3 shows the Energy measurement in the laboratory with standard calculation & prototype energy meter and relative (%) error.

The measured values of current obtained from the standard calculation and



Table 4.3: Result of Energy measurement in the laboratory with standard calculation & prototype energy meter

Number of measurement	Load	Actual power consumed in ONE Hour(WaatHour)	Measured power consumed in ONE Hour(WaatHour)	Relative Error (%)
1	15 watt, 250 volt	13.2	13.1	0.757576
2	11 watt, 240 volt	10.1	10.2	-0.9901
3	100 watt, 230 volt	93.28	93	0.300172
4	100 watt, 250 volt	79.8	79.3	0.626566

compared with proposed method values to check the accuracy of the metering system.

# Chapter 5

## Conclusion

In this thesis design and implementation of reliable digital Energy Meter based on ARM microcontroller is described. With the designed new energy meter; measurement and LCD display of the desired data are possible. Each system section is carefully designed to meet the desired accuracy and bandwidth. C language code is firmware compact and the entire energy calculation algorithm is executed in minimum number of CPU cycle.

In this achievement, different methods for sensing the current and voltage are proposed and implemented. This system is designed based on an ARM microcontroller which acts as a data acquisition processing and display system. A current and a voltage signals are connected to their analog inputs and converted into digital form. The sampled signals of the current and voltage are manipulated by microcontroller to measure energy meter parameter. The microcontroller can therefore evaluate the rms values of measured signals together with the consumed energy at the measurement terminals which enable the calculation of all other energy related quantities. In this case study we proposed a simple and versatile display method where the measured data can be easily monitored and display for user.

The new measurement system will certainly help to decrease efficient usage of time as compared to conventional method of getting the same results. All the table gives comparison between the standard and prototype. It can be concluded that the

accuracy up to 0.1% to 0.2% can be obtained for voltage and current measurement and less than 1% accuracy can be obtained for energy calculation.

Future work may include monitoring system. In monitoring system we can easily acquire all the voltage and current sample in every second. Then time to time we can monitor the signal, if any swell and sag is occur it is display in monitor to inform user.

# Bibliography

- [1] Current transducer la 55-p/sp1. *LEM*, page 3, 2002.
- [2] Vincent G.and S. Sasitharan. M.K.Mishra, K. Karthikeyan. A dsp-based integrated hardware set-up for a dstatcom: Design, development, and implementation issues. *IETE JOURNAL OF RESEARCH*, 56(1):11–21, 2010.
- [3] P. A. V. Loss, M. M. Lamego, G. C. D. Sousa, and J. L. F. Vieira. Single phase microcontroller based energy meter. In *Conference Record - IEEE Instrumentation and Measurement Technology Conference*, volume 2, pages 797–800, 1998. Cited By (since 1996):9.
- [4] Avr465: Single-phase power/energy meter with tamper detection. *Atmel*, page 40, july 2004.
- [5] Tl081 jfet-input operational amplifires. *TEXAS INSTRUMENTATION INCORPORATED*, page 45, SEPTEMBER 2004.
- [6] Shi-Wei Lee, Cheng-Shong Wu, Meng-Shi Chiou, and Kou-Tan Wu. Design of an automatic meter reading system. In *IECON Proceedings (Industrial Electronics Conference)*, volume 1, pages 631–636, 1996. Cited By (since 1996):3.
- [7] Implementation of a single-phase electronic watt-hour meter using the msp430f6736. *TEXAS INSTRUMENTATION INCORPORATED*, page 27, May 2012.
- [8] L. Saranovac, P. Pejovic, and M. Popovic. Digital method for power frequency measurement using synchronous sampling. *IEE Proceedings: Electric Power Applications*, 148(2):225–226, 2001. Cited By (since 1996):2.
- [9] R. G. Jones. A review of precision ac voltage and current measurements. *IEE Colloquium (Digest)*, (161):1/1–1/4, 1997.
- [10] H. Serra, J. Correia, A. J. Gano, A. M. De Campos, and I. Teixeira. Domestic power consumption measurement and automatic home appliance detection. In *2005 IEEE International Workshop on Intelligent Signal Processing - Proceedings*, pages 128–132, 2005. Cited By (since 1996):9.

- [11] C. . Young and M. J. Devaney. Digital power metering manifold. *IEEE Transactions on Instrumentation and Measurement*, 47(1):224–228, 1998. Cited By (since 1996):6.
- [12] U. B. Mujumdar and J. S. Joshi. Microcontroller based true rms current measurement under harmonic conditions. In *2010 IEEE International Conference on Sustainable Energy Technologies, ICSET 2010*, 2010.
- [13] J. Xi and J. F. Chicharo. A new algorithm for improving the accuracy of periodic signal analysis. *IEEE Transactions on Instrumentation and Measurement*, 45(4):827–831, 1996. Cited By (since 1996):58.
- [14] P. Petrovic. New digital multimeter for accurate measurement of synchronously sampled ac signals. *IEEE Transactions on Instrumentation and Measurement*, 53(3):716–725, 2004. Cited By (since 1996):20.
- [15] H. Hindersah, A. Purwadi, Farianza Yahya Ali, and N. Heryana. Prototype development of single phase prepaid kwh meter. In *Proceedings of the 2011 International Conference on Electrical Engineering and Informatics, ICEEI 2011*, 2011.
- [16] T. Dake and E. zalevli. A precision high-voltage current sensing circuit. *IEEE Transactions on Circuits and Systems I: Regular Papers*, 55(5):1197–1202, 2008. Cited By (since 1996):6.
- [17] Gerard N. Stenbakken and Amos Dolev. High-accuracy sampling wattmeter. *IEEE Transactions on Instrumentation and Measurement*, 41(6):974–978, 1992. Cited By (since 1996):15.
- [18] Mohamed H. Shwehdi and Chris Jacobsen. Microprocessor-based digital wattmeter system design. In *Proceedings of the Intersociety Energy Conversion Engineering Conference*, volume 3, pages 1840–1845, 1996. Cited By (since 1996):3.
- [19] P. Oksa, M. Soini, L. Sydnheimo, and M. Kivikoski. Considerations of using power line communication in the amr system. In *2006 IEEE International Symposium on Power Line Communications and Its Applications, ISPLC'06*, pages 208–211, 2006. Cited By (since 1996):9.
- [20] L. Li, H. Xiaoguang, H. Jian, and H. Ketai. Research on the architecture of automatic meter reading in next generation network. In *IEEE International Conference on Industrial Informatics (INDIN)*, pages 92–97, 2008. Cited By (since 1996):3.
- [21] Elham B. Makram, Clarence L. Wright, and Adly A. Girgis. A harmonic analysis of the induction wathhour meter’s registration error. *IEEE Transactions on Power Delivery*, 7(3):1080–1088, 1992. Cited By (since 1996):13.

- [22] Saul Goldberg and William F. Horton. Induction watt-hour meter accuracy with non-sinusoidal currents. *IEEE Transactions on Power Delivery*, PWRD-2(3):683–690, 1987. Cited By (since 1996):2.