

# IMPACT OF IONIC LIQUID ENVIRONMENT ON LYSOZYME STABILITY

A Dissertation

Submitted in partial fulfilment

FOR THE DEGREE OF  
MASTER OF SCIENCE IN CHEMISTRY

Under Academic Autonomy

NATIONAL INSTITUTE OF TECHNOLOGY, ROURKELA

By

**Shubhasmin Rana**

**Rollno. 411cy2032**

*Under the supervision of*

**Dr.Harekrushna Sahoo**

Department of Chemistry



NATIONAL INSTITUTE OF TECHNOLOGY, ROURKELA

ODISHA - 769008

NATIONAL INSTITUTE OF TECHNOLOGY

DEPARTMENT OF CHEMISTRY



### Certification

This is to certify that the dissertation entitled “*Impact of ionic liquid environment on Lysozyme stability*” being submitted by Ms. Shubhasmin Rana to the Department of Chemistry, National Institute of Technology, Rourkela, Odisha for the award of the degree of Master of Science is a record of bonafide research carried out by her under my supervision and guidance. To the best of my knowledge, the matter embodied in the dissertation has not been submitted to any other University/Institute for the award of any Degree or Diploma.

Rourkela

Date:

Dr. Harekrushna Sahoo

Dept. Of Chemistry

National institute of Technolog

Rourkela, Odisha

## *Acknowledgement*

At the very first, I take this great opportunity to express my best regards, sincere thanks from the deepest corner of my heart profound to my guide Dr. Harekrushna Sahoo for providing me the facilities but also a higher learning environment where the creative, curious minds always find their best destination and for his endless help during the lab work. His brilliant suggestions and inspiration helped me to bring out this project report into light.

I am also thankful Dr. Braja Gopal Mishra (H.O.D, Dept. Of chemistry) and all faculties of Chemistry department, NIT Rourkela for their unending help in every steps and encouragement, proficient guidance, suggestions throughout the entire one project duration.

I would like to acknowledge Dr. Suman Jha (Asst. Professor, Dept. Of Life science) for his suggestions regarding this project. Simultaneously, I would also like to thank Dr. Usharani Subuddhi (Asst. Professor, Dept. Of Chemistry) and her PhD students for giving me the opportunity to use their laboratory facilities.

I would like to thank Dr. Garudadhwaraj Hota (Asst. Professor Dept. Of Chemistry) and Dr. Niranjan Panda (Assoc. Professor Dept. Of Chemistry) and their PhD students for allowing me to use their laboratory facilities.

It's my pleasure to thank Dr. Priyabrata Dash (Asst. Professor, Dept. Of Chemistry) and his PhD students Basanti Ekka and Lipika Rout and also my classmates Eeti Chattarjee, Nilendri Rout, Chinmayee Priyadarsini and Aurobinda Mohanty for their co-operation and continuous encouragement throughout the entire period of the project and specially thanks for making a friendly atmosphere in the lab.

I am honestly grateful to my parent for their endless love, unending support and blessing.

Sincerely

Shubhasmin Rana

## DECLARATION

I, Shubhasmin Rana hereby declare that this project report “**Impact of ionic liquid environment on Lysozyme stability**” is the original work carried out by me under the supervision of Dr. Harakrushna Sahoo, Department of Chemistry, National Institute of Technology (NITR), Rourkela and the present work or any other part of this work has not been presented in any other University or Institute for the award of any other degree regarding to my belief.

Shubhasmin Rana

## **ABSTRACT**

Stability of local tryptophan environment (Trp-environment) in Lysozyme was determined in the presence of water miscible aprotic ionic liquids, i.e., 1-ethyl-3-methylimidazolium, 1-butyl-3-methylimidazolium, 1-octyl-3-methylimidazolium cations and different types of anions such as sulphate and chloride, as the additives in water and buffer. Addition of ionic liquids to the protein solution brings a change in the hydrophobic environment of Trptophan in the protein. The disrupting behaviour of the ionic liquids increases with increase in alkyl chain length and the hydrophobicity of the imidazolium cation. It is observed that more is the hydrophobic nature of the substituent more is the disruption in native Trp environment. On the other hand and in the case of anions, anions follows Hofmeister series (i.e., negative compactness effect of chloride is more than sulfate).

## CONTENTS

	<b>Pages</b>
<b>1. INTRODUCTION</b>	<b>8</b>
1.1. Importance of protein	9
1.2. Lysozymes and its structure	9
1.3. Properties and importance of Lysozyme	10
1.4. Importance and applications of ionic liquid	10
1.5. Proposed ionic liquids	12
<b>2. MATERIALS AND METHODS</b>	<b>13</b>
2.1. Materials	14
2.2. Methods	14
2.2.1. Preparation of Lysozyme stock solution	14
2.2.2. Preparation of ionic liquid solution	15
2.2.3. Technique used	15
2.2.4. Measurement of steady state Fluorescence spectroscopy	15
<b>3. RESULTS AND DISCUSSION</b>	<b>17</b>
3.1. Role Anions	18
3.2. Role of Cations	21
<b>4. CONCLUSION</b>	<b>25</b>
<b>5. REFERENCES</b>	<b>26</b>

<b><u>List of Figures</u></b>	<b>page no.</b>
<b>1. Figure 1:</b> Crystal structure of Lysozyme	14
<b>2. Figure 2:</b> Absorption spectra of Lysozyme in presence of EMIMSO <sub>4</sub> and EMIMCl.	18
<b>3. Figure 3:</b> Lysozyme emission spectra as a function of EMIMSO <sub>4</sub>	19
<b>4. Figure 4:</b> Lysozyme emission spectra as a function of EMIMCl	20
<b>5. Figure 5:</b> Comparison of the effects exerted by EMIMSO <sub>4</sub> and EMIMCl	21
<b>6. Figure 6:</b> Lysozyme emission spectra as a function of BMIMCl	22
<b>7. Figure 7:</b> Lysozyme emission spectra as a function of OMIMCl	23
<b>8. Figure 8:</b> Comparison of the effects exerted by OMIMCl, BMIMCl and EMIMCl	23

### **Lists of schemes**

<b>1. Scheme 1:</b> Schematic diagram for the Steady-State Fluorimeter	15
------------------------------------------------------------------------	----

**CHAPTER- 1**  
**INTRODUCTION**



## 1. INTRODUCTION

### 1.1. Importance of protein:-

All most all biological processes are largely contributed by proteins which are made up of one or more amino acids chains. Proteins have a very important function within living organisms. These functions are such as catalysing metabolic reactions, DNA replication, transporting molecules from one location to another etc. Proteins differ from each other in their amino acid sequence besides their functions. Which is detected by the nucleotide sequence of the genes, and which is always present as three-dimensional structure which determines the activity of protein. The amino acids joined together by a peptide bond between the carboxylic and amino groups of adjacent amino acid and form a polymer chain of amino acids. The physical and chemical properties, folding, stability, activity of protein depends on the sequence of amino acids. [1-4]

Besides the peptide bonds, sometimes non-peptide groups are attached to the protein called prosthetic group or cofactors. All enzymes are made up of protein which catalyzes biochemical reactions. Proteins are also necessary in animal diets. Proteins are used in different ways and also very essential for body which is discussed above and it is only possible for their three dimensional structure i.e. the folded structure which is stable that means stability of protein plays an important role in all the application or uses which is possible for protein.

In recent years the production and application of proteins are increased not only for biochemical research but also for food chemical and pharmaceutical industries. So proteins exhibit extremely beautiful biological activities. Three dimensional proteins show the stability due to several weak interactions such as ionic effects, hydrogen bonds, and hydrophobic with solvents as well as other entities. These weak interactions are work as a function of environment. Always the proteins exist as an equilibrium between folded unfolded states.

Keeping this in mind we are very much interested for the better study of the stability (local and global) of protein in different solvent conditions. Going with the solvent conditions, we used different ionic liquids explained in details later. Many proteins were there but we are interested for only lysozyme hen egg white protein due to its following advantages. [5, 6]

### 1.2. Lysozyme and its structure:-

Lysozyme is N-acetyl-muramic-hydrolase is a bacteriolytic enzyme commonly found in nature. It is found as a single peptide chain which consists of 129 amino acids in which the N terminal amino acid is Lysine and Leucine is the C terminal. In Lysozyme four disulphide (S-S) bonds are present which cause high thermal stability of the enzyme and also six helix region. Hen egg white is an easy and rich source of lysozyme which is found as monomer in nature but Lysozyme is more active in dimeric or polymeric form. Dimeric form exhibits therapeutic, antiviral and anti-inflammatory properties. [7, 8]

### **1.3. Properties and importance of Lysozyme**

Two properties of lysozyme i.e Bacteriostatic and Bactericidal have been used both to preserve various kind of food, as well as in pharmaceutical industries, human and veterinary medicine. Lysozyme shows antibacterial activity against a certain no. of food spoilage bacteria and pathogens. Almost all secretory body fluids and tissues of human and animal organisms contain lysozyme. Lysozyme shows antimicrobale activity against a limited spectrum of bacteria and fungi and also the enzyme activity of lysozyme can be enhanced by substances like EDTA, ripoly phosphate as well as some naturally occurring anti microbial agents. In the lysozyme polypeptide sequence the nature of the amino acid side chain leads to the region of hydrophobicities and polarities of the enzyme structure. For all proteins hydrogen bonds are essential for stability. The double bonds of the alpha carbon in the main chain of lysozyme cause torsional strain, but lysozyme is limited to specify hydrogen bonding between the amino acid residues. Thus it is very much essential to study its stability in different environments along with the efficient expression and purification levels. Therefore looking towards the wide applications in protein stability and its effect on the folding pathways, we used. [9, 10]

### **1.4. Importance and applications of Ionic liquids:-**

An ionic liquid is nothing but a salt in the liquid state whose melting point is below some arbitrary temperature (100°C). Ionic liquids are made up off ions and short lived ion pairs. Any salts which melt without decomposition or vaporisation usually forms ionic liquid. When ionic liquid is cooled, forms an ionic solid which is either crystalline or glassy. Ionic liquids are recognised as normal solvents. Mainly ionic liquids consist of bulky, non-symmetric organic cations such as imidazolium, pyrolydinium, pyridinium, ammonium, or organic anions such as tetrafluoroborate, bromide ions.

The unique properties of ionic liquids include negligibility vapour pressure, good thermal stability, tunable viscosity and miscibility with water and organic solvents along with these are poor conductors of electricity, low combustibility wide liquid regions, favourable solvating properties, highly viscous, low toxicity, non-ionizing in nature. Ionic liquids are easily removable in case of organic compounds and metal ions which are as a result of their unique structure. The properties like non-flammable and non-volatile of ionic liquid makes an excellent choice for the development and it is also safety. Ionic nature of ionic liquids can change the selectivity and variety of chemical reactions. The cationic and anionic constituents are on the basis of some properties such as their polarity, hydrophobicity and other chemical and physical properties. Due to the tunable property of ionic liquids are used as designer solvents and thus increase the potential application. The presence of typical ions in ionic liquid show moderate polarization charge densities which is due to delocalisation of the molecular charge. Ionic liquids are of two different types (1) simple salts (which is made of a single cation), (2) binary ionic liquids (where equilibrium is involved). [11, 12]

The common cations and anions used in ionic liquids: cations like hexafluorophosphate, ethylsulphate, 1-alkylpyridinium, 1,1-dialkylpyridinium, 1-ethyl-3-methylimidazolium, 1,3-dialkylimidazolium, tetraalkylammonium, tetraalkylphosphonium, 1-alkylpyrrolinium, 1,3-dialkyltrazolium, hexaalkylguaninium, 1-alkylthiazolium; and anions like chloride, bromide, iodide, nitrate, nitride, isothiocyanate, nitrite, [amino acetate]<sup>-</sup>, [p-MeC<sub>6</sub>H<sub>4</sub>SO<sub>3</sub>]<sup>-</sup>, [CF<sub>3</sub>CO<sub>2</sub>]<sup>-</sup>, [OCN]<sup>-</sup>, [N(CN)<sub>2</sub>]<sup>-</sup>, [Al(Et)Cl<sub>3</sub>]<sup>-</sup>, [Al<sub>2</sub>Cl<sub>7</sub>]<sup>-</sup>, [Al<sub>3</sub>Cl<sub>10</sub>]<sup>-</sup>, [Al<sub>2</sub>(Et)<sub>2</sub>Cl<sub>5</sub>]<sup>-</sup>, [Al(CH<sub>2</sub>CF<sub>3</sub>)<sub>4</sub>]<sup>-</sup>, [MeCO<sub>2</sub>]<sup>-</sup>, [SbF<sub>6</sub>]<sup>-</sup>, [P(C<sub>2</sub>F<sub>5</sub>)<sub>3</sub>F<sub>3</sub>]<sup>-</sup>, [BF<sub>4</sub>]<sup>-</sup>, [(RO)<sub>2</sub>PO<sub>2</sub>]<sup>-</sup>, [ROSO<sub>3</sub>]<sup>-</sup>, [B(oxalate)<sub>2</sub>]<sup>-</sup>, [B(C<sub>6</sub>H<sub>44</sub>-CF<sub>3</sub>)]<sup>-</sup>, [C(CN)<sub>3</sub>]<sup>-</sup>, [F(HF)<sub>n</sub>]<sup>-</sup>, [(CF<sub>3</sub>SO<sub>2</sub>)<sub>2</sub>N]<sup>-</sup>, [CF<sub>3</sub>SO<sub>3</sub>]<sup>-</sup>, [ROSO<sub>3</sub>]<sup>-</sup>, [(RO)<sub>2</sub>PO<sub>2</sub>]<sup>-</sup>, [PF<sub>6</sub>]<sup>-</sup>. [13, 14, 15] In general, ionic liquids have various applications. Some of them are mentioned below.

- (a) **Pharmaceutical Industries** :- There are three types of generation of ionic liquid which is active as a pharmaceutical industries i.e., the first generation is important for their physical and chemical properties like density, viscosity, solubility, chemical stability etc. the second generation is important for the tunable properties of ionic liquid and the third generation is recent generation which involve pharmaceutical ingredients. The design of active pharmaceutical ingredients (APIs) (which is a pharmaceutical drug or pesticides and biologically active) in the form of ionic liquids is to offer innovative solutions in the recent treatment and delivery options. Using ionic liquids as a medium, many pharmaceutical drugs are formed which provide many unequal and wonderful properties compared to usual counterparts. Recently, it is found that active pharmaceutical ingredients are easily converted to ionic liquids. [16, 17]
- (b) **Antibacterial Activity**:- Ionic liquids show a great activity against gram-positive and gram-negative bacteria fungi and algae. The ionic liquid 1-alkylquinolinium ionic liquid has a vigorous activity against microorganisms which grown in both planktonic and sessile mode of growth. Some room temperature ionic liquids like tetra butyl ammonium salts i.e., formate, acetate, propionate, benzoate, salicylate, are prepared by neutralization of tetrabutylammonium hydroxide and also the corresponding acids are soluble in water.
- (c) **Antitumor Activity**:- The cations like imidazolium, phosphonium, and ammonium present in ionic liquid as anticancer. Preliminary structure gives more information about the chain length of alkyl substitution which plays an important role towards antitumor and cytotoxicity properties of ionic liquids. The chain length of alkyl substitution at 3- position of imidazole ring plays an important role towards anti-tumor activity and cytotoxicity in these ionic liquids.

Along with the above applications, ionic liquids are also applied in biomedical and biotechnological sector. Enzymes are attached with ionic liquid remain stable and catalytically active whereas not active or it is stable in normal most of organic solvent. Many ionic liquids are appropriate for biotechnological application because of their solubilities properties and also toxicologically good. [18, 19, 20]

Certain ionic liquids are of high demand as they can be used as solvent and help to dissolve non polar substrates with unaltered enzyme activity. Ionic liquids are also used as solvents for non aqueous reactions. They are non-volatile and can be made from nontoxic components as a result of which ionic liquids are called as greener solvents compared to all other organic solvents. Based on the above advantages, we used ionic liquids (as a function of the type of cations and anions).

We are studying the Trp environment (degree of solvent exposure) of Lysozyme protein in ionic liquid medium using fluorescence spectroscopy. There were so many ionic liquids which have already been used in the study of protein stability but we have mainly concentrated on four ionic liquids i.e. 1-ethyl-3-methylimidazolium methylsulfate, 1-ethyl-3-methylimidazolium chloride, 1-butyl-3-methylimidazolium chloride and 1-octyl-3-methylimidazolium chloride. As it is well known from the literature that with proper selection of anion and cation the protein stability in liquid state can be increased, we employed the above mentioned ionic liquids on varying cations and anions to assess their effect on protein stability. [21, 22, 23]

### **1.5. Proposed Ionic liquids:-**

From various observations it is concluded that a small change in imidazolium cation (such as either increase or decrease alkyl chain length), the physical properties change severely. It is also observed that with increase in alkyl chain length, density of ionic liquid decreases and with increase in molecular weight of anion, density increases. The chain length of alkyl which is attached with imidazolium cation decides the stability or renaturation and instability or denaturation properties of Lysozyme.

With increase in anionic size, the thermal stability increases and with increasing the number of anions in ionic liquid heat capacity also increases. From literature view it has been seen that anion has greater effect on hydrogen bonding in comparison to cation in case of room temperature ionic liquid.

The preparation of 1-ethyl-3-methylimidazolium methylsulfate is very easy in halide free manner using diethyl sulphate and it is also less expensive, water miscible, not very reactive in air i.e. air stable and has low viscosity. Presence of chloride ion increases the viscosity of ionic liquid whereas presence of water and other co-solvents reduce the viscosity. With increase of chloride concentration viscosity increases accordingly. When viscosity increases the cohesive force also increases through hydrogen bonding between the chloride ion and the protons of the imidazolium ring. But presence of chloride ion decreases the density of ionic liquid. In case of proton NMR spectra of ionic liquid containing chloride ion causes the downfield shift.

We are studying the local environment of fluorescent amino acid like phenylalanine, tyrosine, tryptophan and cysteine present in the protein using fluorescence spectroscopy. Moreover, we are very much interested to study the local environment of tryptophan amino acid which is present in Lysozyme protein in presence of ionic liquid. [24, 25]

**CHAPTER- 2**  
**MATERIALS AND METHODS**

## 2.1 MATERIALS:

### Protein:-

Chicken egg white Lysozyme (Product No-L6876) was purchased from Sigma Aldrich. The native fluorescence of tryptophan present is used for the stability study of protein. It was used without further purification.

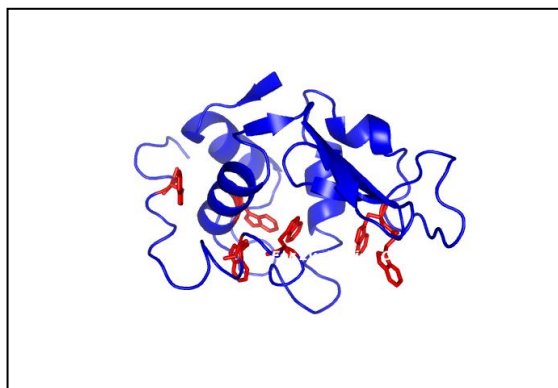
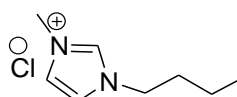
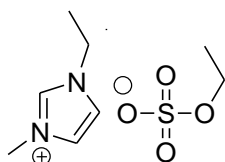

**Figure 1:** Crystal structure of Lysozyme (PDB ID: 4E0F). Tryptophan residues are highlighted in red. There are total six tryptophans present in Lysozyme. Out of which, four are partially or fully exposed to solvent whereas; two are remain in the hydrophobic environment.

From the crystal structure of Lysozyme, it has been shown that it contains protein contains six Trp. Out of these only two are in hydrophobic environment and rests have exposed to solvent.

### Ionic Liquids:-

- 1) **1-ethyl-3-methylimidazolium ethylsulfate**      2) **1-butyl-3-methylimidazolium chloride**



- 3) **1-ethyl-3-methylimidazolium chloride**

- 4) **1-octyl-3-methylimidazolium chloride**

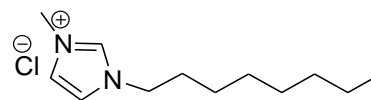
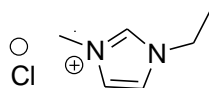

### Solvent:-

Millipore water is used for all experiments as the solvent medium.

## 2.2 METHODS:

### 2.2.1 Preparation of Lysozyme stock solution:

The Lysozyme stock solution was prepared in fresh Millipore water each time. The protein solutions were made by measuring the required amount of protein of certain concentration. The protein solution was allowed for the homogeneous mixing before starting the measurement.

### 2.2.2 Preparation of ionic liquid solution:

The stock solutions of four different types of ionic liquids were prepared by measuring required amount of solute followed by the addition of solvent. Then the dilution was done to obtain the required concentration of experimental solution.

## 2.3 TECHNIQUE USED

### 2.3.1 Instrumentation

The fluorescence measurements were done using Horiba Jvon Spectrometer (Fluoromax-4P).

### 2.3.2 Measurement of Steady-State Fluorescence Spectroscopy:

The spectrofluorimeter is an instrument which takes the advantage of intrinsic or extrinsic fluorescent properties of the compounds in order to provide information regarding their concentration and chemical environment in a sample. A certain excitation wavelength is selected, and the emission is observed either at a wavelength scan to record the intensity versus wavelength, also called as steady state emission spectra. The slit widths are also fixed for a particular experiment at which the best output is obtained. In the experiment the excitation wavelengths selected was 295 nm (to avoid the excitation of tyrosine, phenylalanine and cysteine of protein) and the emission spectra were recorded in the range of 325nm to 450 nm with slit widths of 3 or 5 nm.

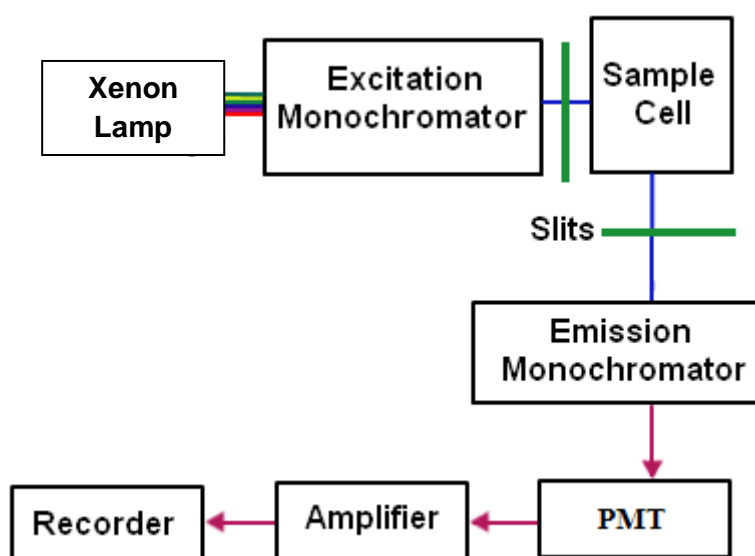

**Scheme 1:** Schematic diagram for the Steady-State Fluorimeter setup.

### **Basic Components of fluorimeter:-**

- 1) Excitation source is provided by Xenon lamp.
- 2) Light passes through a excitation filter before entering sample compartment prior to it, light passes through the excitation monochromator.
- 3) Light is absorbed by the fluorescent substance
- 4) After excitation of the fluorescent substance, it return to ground energy state and light with a longer wavelength (fluorescence) is emitted.
- 5) Fluorescent light passesthrough a emission filter which is the excitation beam path is right angle to the emission beam in the set up.
- 6) The amount of light passing through the emission is measured with a photomultiplier tube (PMT) fluorophores (in our case, it is tryptophan) preferentially absorb photons whose electric vectors are aligned parrel with transition moment.



**CHAPTER-3**  
**RESULTS AND DISCUSSIONS**

## RESULTS AND DISCUSSION

### 3.1. Role of Anions:

**3.1.1. 1-Ethyl-3-methylimidazolium Ethyl Sulfate (EMIMSO<sub>4</sub>):** Steady-state fluorescence measurements with EMIMSO<sub>4</sub> as an additive in water and PBS buffer (pH 7.4) indicate alternation in both compactness and solvent exposure of the Trp environment with respect to the native protein. In the case of water as the dissolving medium for EMIMSO<sub>4</sub>, Trp environment in Lysozyme gets more compact compared to the native Trp structure as a function of concentration of the ionic liquid whereas the Trp opens up and gets more exposed to the solvent in the case of buffer (PBS of pH 7.4) as the solvent medium.

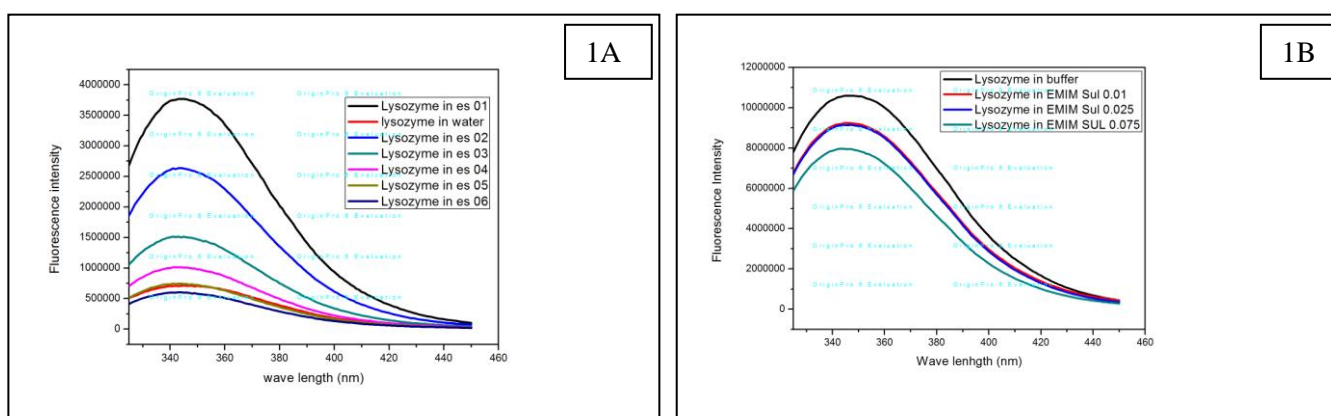

**Figure 3:** Lysozyme emission spectra as a function of EMIMSO<sub>4</sub> concentration in water (1A) and PBS (1B).

Particularly, with water as the dissolving solvent, the hydrophobic nature of Trp environment increases with a maximum at 0.1 M and shows a gradual decrease with increase in concentration. However, below 0.5 M ionic liquid, the compactness of the Trp environment is still high compared to the native protein (figure 3). Whereas, in the case of PBS as the solvent medium, Trp shows a gradual increase towards the destruction of the hydrophobic environment and gets out of the hydrophobic pocket slowly with increase in the concentration of EMIMSO<sub>4</sub> (concentration range: 0.1 to 1 M) and exposes to the solvent and thus, the fluorescence intensity decreases due to the quenching by the water molecules.

### 3.1.2. Ethylmethylimidazolium Chloride (EMImCl):

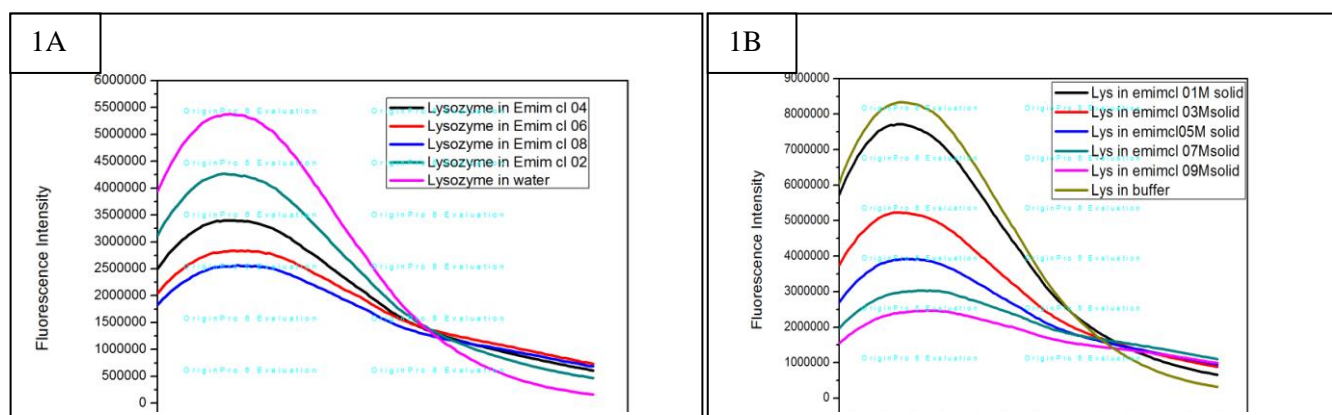
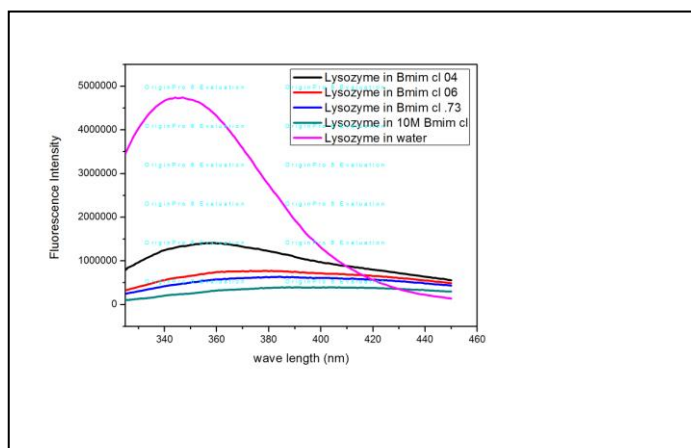

**Figure 4:** Lysozyme emission spectra as a function of EMIMCl concentration in water (1A) and PBS (1B).

From the experimental observations, it is pointed out that the fluorescence intensity decreases on addition of EMIMCl with a concentration variation of 0.1 to 1 M (figure 3). Irrespective of the solvent medium and EMIMCl concentration (concentration range: 0.1 to 1 M), Trp shows a gradual increase towards the destruction of the hydrophobic environment and gets out of the hydrophobic pocket and exposes to the solvent and thus, the fluorescence intensity decreases due to the quenching by the water molecules. The decrease in the fluorescence intensity could be as a result of the chaotropic nature of the chloride ion.

### 3.2. Role of Cations:

#### 3.2.1. *Butylmethylimidazolium Chloride (BMIMCl)*:



**Figure 6:** Lysozyme emission spectra as a function of BMIMCl concentration in water.

From the experimental observations, it is observed that the fluorescence intensity decreases on addition of BMIMCl as a function of the concentration range of 0.1 to 1 M (figure 4). Due to the disruption nature of BMIMCl, Trp shows a gradual increase in the destruction of the hydrophobic environment and gets out of the hydrophobic environment and exposes to the solvent (figure 6).

## 4. CONCLUSION

It is observed that the destabilization of the protein or the disruption of the hydrophobic core depends on the alkyl groups attached to the imidazolium cation, i. e., with increasing in chain length, the destabilization/unfolding of Lysozyme and disruption of the Trp-hydrophobic environment increases. From various experiments, it is concluded that the destabilizing characteristics of Lysozyme increases with increase in the alkyl chain length or the chaotropic character of the individual cations and anions.

## 5. REFERENCES

1. Hidetaka Noritomi, Ken Minamisawa, Reo Kamiya, Satoru Kato, J. Biomedical Science and Engineering, 2011, 4, 94-99
2. Robert Buchfink, Alexander Tischer, Ganesh Patil, Rainer Rudolph, Christian Lange, Journal of Biotechnology 150 (2010) 64–72
3. Gutteridge A, Thornton JM (2005). "Understanding nature's catalytic toolkit". *Trends in Biochemical Sciences* 30 (11): 622–29
4. Hey J, Posch A, Cohen A, Liu N, Harbers A "Fractionation of complex protein mixtures by liquid-phase isoelectric focusing". *Methods in Molecular Biology*. *Methods in Molecular Biology* (2008) 424: 225–39.
5. Renata Cegielska-Radziejewska, Grzegorz Leśnierowski, Jacek Kijowski, polish journal of food and nutrition sciences, Pol. J. Food Nutr. Sci. 2008, Vol. 58, No. 1, pp. 5-10
6. . Sara Mangialardo, Lorenzo Gontrani, Ruggero Caminiti, Paolo Postorinod,
7. Matthias Buck, Sheena E. Radford, and Christopher M. Dobson', *Biochemistry* 1993, 32, 669-678 669
8. Akio Kato,' Kazuaki Minaki, and Kunihiko Kobayashi, *J. Agric. Food Chem.* 1003, 41, 540-543
9. Etsushi Yamamoto & Satoshi Yamaguchi & Teruyuki Nagamune, *Appl Biochem Biotechnol* (2011) 164:957–967
10. Shouhei Mine, Tadashi Ueda, Yoshio Hashimoto and Taiji Imoto, *Protein Engineering* vol.10 no.11 pp.1333–1338, 1997
11. Dandan Han and Kyung Ho Row, *Molecules* 2010, 15, 2405-2426
12. J. O. Valderrama, and P. A. Robles, *Ind. Eng. Chem. Res.* 2007, 46, 1338-1344
13. Adela Ferná ndez, Jose´ S. Torrecilla, Julia´ n Garcí ´a, and Francisco Rodrí guez, *J. Chem. Eng. Data* 2007, 52, 1979-198
14. Trevor M. Letcher, Urszula Doman´ska b, Małgorzata Marciniak b, Andrzej Marciniak , *J. Chem. Thermodynamics* 37 (2005) 587–593
15. Kenneth R. Seddon, Annegret Stark, and María-José Torres, *Pure Appl. Chem.*, 2000, Vol. 72, No. 12, pp. 2275–2287
16. Carlos Rey-Castro and Lourdes F. Vega, *J. Phys. Chem. B* 2006, 110, 14426-14435
17. Enrique G. Yanes, Samuel R. Gratz, Michael J. Baldwin, Sara E. Robison, and Apryll M. Stalcup, *Anal. Chem.* 2001, 73, 3838-3844
18. Marcos Larriba, Silvia Garcí a, Juli\_an Garcí a, Jos\_e S. Torrecilla, and Francisco Rodrí guez , *J. Chem. Eng. Data* 2011, 56, 3589–3597
19. Kilivelu Ganesan and Yatimah Alias, *Int. J. Mol. Sci.* 2008, 9, 1207-1213; DOI: 10.3390

20. A.L. Saroj and R.K. Singh, Phase Transitions Vol. 84, No. 3, March 2011, 231–242
21. Hideaki Itoh, Kensuke Naka, and Yoshiki Chujo, J. AM. CHEM. SOC. 2004, 126, 3026-3027
22. Ninomiya, K.; Yamamoto, T.; Ohedab, T.; Satob, K.; Sazakic, G.; Matsuur, Y. Morphology and solubility of multiple crystal forms of Taka-amylase A. J. Cryst. Growth. 2001, 222, 311–316.
23. Russell A. Judge, Sumiko Takahashi, Kenton L. Longenecker, Elizabeth H. Fry, Cele Abad-Zapatero, and Mark L. Chiu, Crystal Growth & Design, Vol. 9, No. 8, 2009
24. William T. Heller, Hugh M. O'Neill, Qiu Zhang, and Gary A. Baker, J. Phys. Chem. B 2010, 114, 13866–13871
25. Hong Sun, J Porous Mater (2006) 13: 393–397