

Beamforming in MIMO Radar

Nilay Pandey

Roll No-212EC6192



Department of Electronics and Communication Engineering

National Institute of Technology Rourkela

Rourkela

2014

Beamforming in MIMO Radar

A thesis in Partial Fulfillment of the Requirements for the Degree of

Master of Technology

In

Signal and Image Processing

by

Nilay Pandey

Roll No-212EC6192

Under the Supervision of

Prof. L. P. Roy



Department of Electronics and Communication Engineering

National Institute of Technology Rourkela

Rourkela

2014

DECLARATION OF ORIGINALITY

I hereby declare that this thesis was composed entirely by me and all information in this thesis has been obtained and presented in accordance with academic rules and ethical conduct. The work reported herein was conducted by me in the Department of Electronics and Communication Engineering at National Institute of Technology, Rourkela. I also declare that, as required by these rules and conduct, I have fully cited and referenced all material and results that are not original to this work.

Nilay Pandey

Roll No- 212EC6192

Dept. of ECE

NIT, Rourkela

CERTIFICATE

This is to certify that the work in this thesis entitled “Beamforming in MIMO radar” by Mr. Nilay Pandey has been carried out under my supervision in partial fulfillment of the requirements for the degree of Masters of Technology in Signal and Image Processing during session 2012-2014 in the Department of Electronics and Communication Engineering, National Institute of Technology, Rourkela, and this work has not been submitted elsewhere for a degree.

Dr. L. P. Roy
Assistant Professor,
Dept. of Electronics & Communication Engg.
NIT, Rourkela.

Acknowledgement

I would like to thank my advisor, Professor L. P. Roy, for his excellent guidance and support throughout the thesis work. He has motivated me to be creative and taught the ethics of research and the skills to present ideas and writing papers.

I would also like to express gratitude to our HOD Prof. Sukadev Meher, for providing the support and facilities for the completion of this project. I would like to thank Faculty Members, Electronics and Communication department for their constant encouragement.

I am also grateful to all friends and colleagues for their support and for being actively involved in my step by step progress. The discussions and conversations with these people was always very productive and motivating.

Finally, I would like to thanks my parents who have always been very supportive and understanding throughout my life.

Nilay Pandey
Roll No- 212EC6192
Dept. of ECE
NIT, Rourkela

Abstract

Radar is a system of transmitters and receivers that can detect, locate and measure the speed of a target using electromagnetic waves. Radar perform many other tasks such as geo sensing, terrain mapping and air traffic control.

MIMO radars represent a new generation of radars. In contrast to the traditional phased-array radar in which the transmit elements can transmit only the scaled versions of same signal, a MIMO radar allows the transmitters to transmit multiple signals. This waveform diversity offers enhanced flexibility in transmit beampattern synthesis which is an important area of MIMO radar signal processing.

In this thesis, we provide an overview of MIMO radar and the advantages it offers as compared to its phased array counterpart. We discuss transmit beamforming in MIMO radar and develop the signal model for it. Algorithms for transmit beamforming are discussed. In this thesis we propose two algorithms where we use convex optimization to optimize the signal covariance matrix.

Keywords: Multiple Input Multiple Output (MIMO) Radar, Waveform Diversity, Covariance Matrix, Target, Steering Vector

Table of Contents

DECLARATION OF ORIGINALITY	I
CERTIFICATE	II
Acknowledgement	III
Abstract	IV
List of figures.....	VII
Chapter 1.Introduction	1
1.1 Introduction to radar and MIMO radar systems	1
1.2 Beamforming	6
1.3 Literature Review	8
1.4 Motivation.....	11
1.5 Thesis outline	12
1.5.1 Chapter 1- Introduction	13
1.5.2 Chapter 2- MIMO radar: an overview.....	13
1.5.3 Chapter 3- Transmit Beamforming in MIMO radar.....	13
1.5.4 Chapter 4- Conclusion and future work	13
1.6 Notations.....	14
Chapter 2. MIMO radar: an overview.....	15
2.1 Glossary of important terms	15
2.2 Antenna array.....	16
2.3 Multistatic radar system	17
2.4 Phased Array Radar.....	18
2.4.1 Signal Model.....	20
2.4.2 Beamforming in phased array radar	21
2.5 MIMO radar.....	23
2.5.1 MIMO channel.....	24
2.5.2 MIMO virtual array	25
2.5.3 Improvements offered by MIMO radar	26
Chapter 3. Transmit Beamforming in MIMO radar.....	28
3.1 Problem Formulation.....	28

3.2 Example	30
3.4 Transmit Beampattern Synthesis	31
3.4.1 Existing methods	32
3.5 Proposed method	32
3.5.1 Beampattern matching algorithm	33
3.5.2 Beampattern matching algorithm with cross correlation beampattern and sidelobe considerations	35
3.6 Simulation results	37
Chapter 4. Conclusion and Future Work	41
4.1 Conclusion	41
4.2 Future Work	42
References	43

List of figures

Fig 1.1	basic block diagram of (a) monostatic and (b) bistatic radar system	3
Fig 1.2	Representation of a basic MIMO radar system.	5
Fig 1.3	An ULA with $N = 5$ elements	7
Fig 1.4	Far field approximation holds for proper values of the ratio $\frac{d}{r}$	8
Fig 1.5	Angle estimation Performance	10
Fig 2.1	Multistatic radar system (Single transmit element and multiple receive elements)	17
Fig 2.2	Multistatic radar system (spatially separated radars operating in bistatic mode)	18
Fig 2.3	Illustration of a phased array radar	19
Fig 2.4	A three-element beamformer	22
Fig 2.5	MIMO radar vs Phase array radar	24
Fig 3.1	Transmit/Receive elements and spherical coordinates	29
Fig 3.2	Beampattern obtained for different values of ρ	31
Fig 3.3	Beampattern designed with 2-norm criterion	38
Fig 3.4	Beampattern designed with minmax criterion	39
Fig 3.5	Mean square error comparison for 2-norm and minimax criterion	39
Fig 3.6	Beampattern designed with algorithm 2	40
Fig 3.7	Mean square error for algorithm 2	40

Chapter 1

Introduction

In this chapter we briefly introduce the basic concepts of radar and MIMO radar and also introduce the concept of beamforming in a radar system. We give an idea of the state of current MIMO radar research by providing a brief survey of relevant literature. This Chapter is organized into six sections: section 1.1 gives the basic introduction of radar and MIMO radar system. In section 1.2 we introduce the concept of beamforming. We survey some of the literature relevant to our project in section 1.3. In section 1.4 we derive the motivation for this project and section 1.5 gives an outline of this thesis. The notations used in the thesis are provided in section 1.6.

1.1 Introduction to radar and MIMO radar systems

The working of a radar is based on transmitting electromagnetic energy and then receiving the echoes returned by the targets. A radar performs three basic functions: detection, parameter estimation and tracking [1-4]. Of these the most fundamental function of the radar is detection. Once the echo signal is received at the receiver, it is necessary to determine whether the received signal is a signal reflected by the target or is just noise. The parameter determining the success of

detection process is the signal to noise ratio (SNR) at the receiver. For proper detection, the radar system must be able to distinguish the echo signals returning from the target from the noise components.

Once detection is done one can calculate the range which is the separation between the radar system and the target. Other target parameters like velocity, direction of arrival etc. can also be estimated from the received signal.

Tracking is providing a trajectory for the targets motion and predicting where the target would be in the future by observing the targets movements over a period of time. Radar can perform the tracking operation using a set of dedicated filters.

The recent advances in sensing, computing and signal processing techniques have made the radars capable of doing certain specialized tasks. One important of such tasks being radar imaging. This new technology enables us to generate high resolution two or three dimensional maps of the surfaces of planetary bodies.

The radars employ different types of antennas, transmitter and receiver structures and processing units depending upon the requirements of the application. Depending upon the relative positioning of the transmitter and the receiver, the radar system can be broadly divided into two categories: *monostatic radars and bistatic radars*. In monostatic radars the transmitters and the receivers are located at the same location while in a bistatic radar the transmitters and the receivers are located far away from each other compared to the wavelength being employed in the radar system. Most of the modern radar system are designed to be monostatic [4], [5].

The radar systems employ different types of probing signals depending upon the sensing application. Most of the radar systems can be categorized in to *continuous waveform radars* and

pulse radars based on the signal being transmitted by the radar [2-6]. The former transmits a single waveform continuously while the later transmits short pulses of the probing signal. Most of the radar systems now a days are pulse radars.

Fig. 1.1 shows the basic block diagram of radar system. This is only a basic representation and practical radars are much more complex and have many more blocks which perform specialized tasks. The transmitter radiates the probing signal into the space. The echoes returned from the target are detected and amplified by the receiver. In case of the monostatic radar system (Fig. 1.1.a) the duplexer allows the time sharing of the same antenna by both the transmitter and the receiver. The discriminator block performs the function of separating the echo signal from the noise and the performance of the discriminator largely depends on the available SNR at the receiver. The display unit displays the output of the receiver unit so that the information can be used by the radar operator.

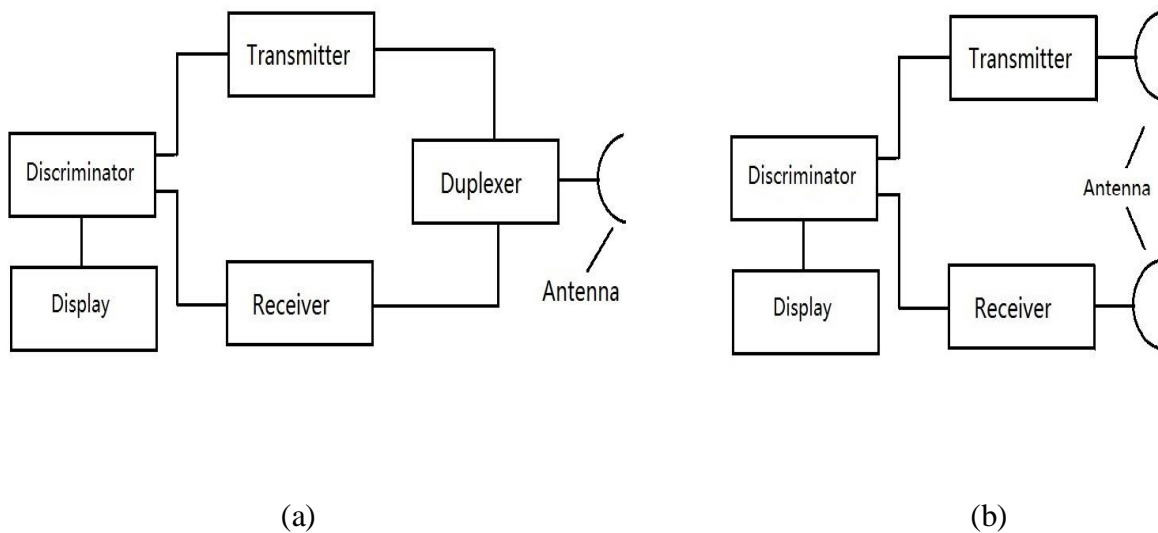

Fig. 1.1 basic block diagram of (a) monostatic and (b) bistatic radar system

The radar equation can be used to describe the factors which influence the performance of a radar. One form of the radar equation which gives the received signal power in terms of the radar characteristics is given as [1], [7]:

$$P_r = \frac{P_t G_t}{4\pi R^2} \times \frac{\sigma}{4\pi R^2} \times A_e \quad (1-1)$$

Here P_t is the transmitted power, G_t is the gain of the transmitting antenna, R is the distance in meters from the transmitting antenna, σ is the target cross section in square meters and A_e is the effective aperture area of the antenna.

MIMO radars represent a new field of research in radar signal processing which has drawn the attention of researchers world-wide. MIMO radars can be considered to be a generalized form of multistatic radar system. The basic difference between a multistatic radar system and MIMO radar is that a significant amount of local processing is done by independent radars that form the multistatic radar system and there is a central unit that processes the outcomes of these radars in a proper way. Whereas in MIMO radar all of the available data at multiple receivers is jointly processed to make an overall decision about target's existence. As implied by the name, a MIMO radar has multiple transmitters and receivers. The collected information then, can be processed jointly. In case of traditional phased array radars only the scaled versions of the same waveform can be transmitted but a MIMO radar allows the individual antennas are allowed to transmit waveforms independently [8-9]. That means a MIMO radar system can transmit waveforms which can have any degree of correlation between them. Fig 1.2 provides an illustration of a basic MIMO radar.

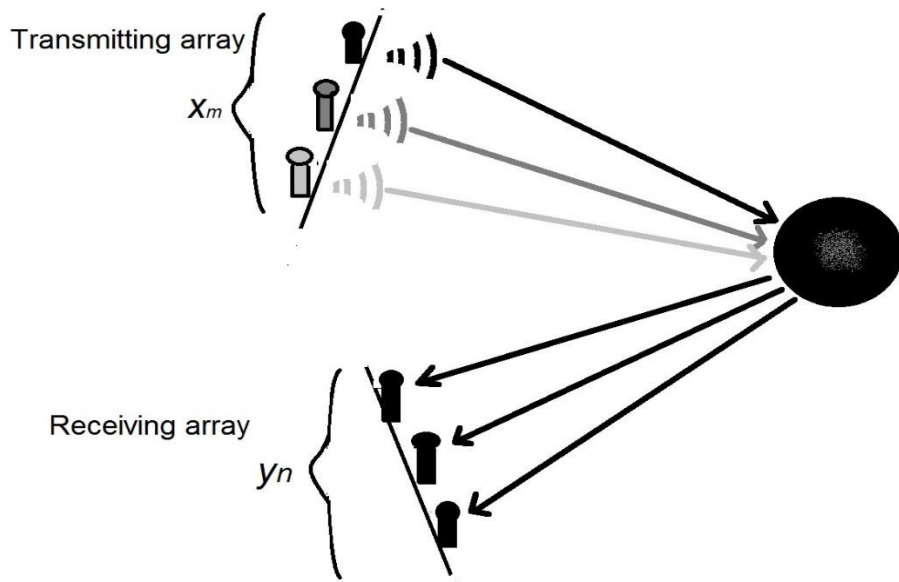

Fig 1.2 Representation of a basic MIMO radar system. The x_m 's and y_n 's represent the position of the respective transmitters and receivers.

By the very definition of a MIMO radar most of the traditional array radar systems can be considered to be special cases of the MIMO radar system. There are many domains of operation of a MIMO radar but most of them can be categorized in to two classes: *the statistical MIMO radar* and *the coherent MIMO radar*. In case of a statistical MIMO radar the array elements (both at the transmitter and the receiver) are broadly spaced. Such an arrangement provides independent scattering response for each antenna pair. In a coherent MIMO radar the array elements are closely spaced such that the far field operation for the radar can be assumed.

There are many possible signaling techniques which can be used for MIMO radar. The waveforms transmitted by MIMO radar may be correlated or may be uncorrelated. For computational convenience it is assumed that each of the transmitting antenna transmits orthogonal waveforms. At the receiver a set of matched filters is used to extract these orthogonal waveforms. These

extracted signals at the receiver provide information about the transmitting path between each individual antenna pair. In this thesis we consider only the colocated MMO radars where each transmit-receive antenna pair is assumed to occupy the same location.

MIMO radar system offers many advantages which include excellent capability for rejecting clutter interference [10], enhanced parameter identifiability [10-11], and improved flexibility in designing transmitting beampattern [11]. We shall introduce MIMO radar in more details in chapter 2.

1.2 Beamforming

The gain of an antenna is dependent on the direction in which the signal is transmitted or the direction from which the signal is received. This gain of the antenna written as a function of the direction θ is called the beampattern $G(\theta)$. We can also define the beampattern $P(\theta)$ of a radar as the power radiated by it as a function of the direction θ .

Thus to have a large gain towards the desired direction, one has to rotate the antenna towards that angle. This is practically very difficult to do so because most of the modern radar systems have large and sophisticated antennas. Also because of the large size of the antennas, the mechanical movement of such antennas is very slow and thus it becomes very difficult to track fast moving targets.

To overcome the need for mechanically rotating the antenna and change the beampattern at a faster rate we can employ a technology known as beamforming. Using beamforming we can change the beampattern electronically. This is done using multiple antennas and generally these antennas are assumed to have omnidirectional beampatterns, i.e. have a constant gain for all θ (usually the gain is 1).

These multiple antennas are arranged in an arrangement called Uniform Linear Array (ULA). In an ULA, the antennas are spaced uniformly (usually $\frac{\lambda}{2}$ spacing) along a straight line. Fig 1.3 shows the geometry of such a ULA with $N=5$ elements with respect to a wavefront propagating in a direction p . These elements have been numbered 1, 2, 3, 4 and 5.

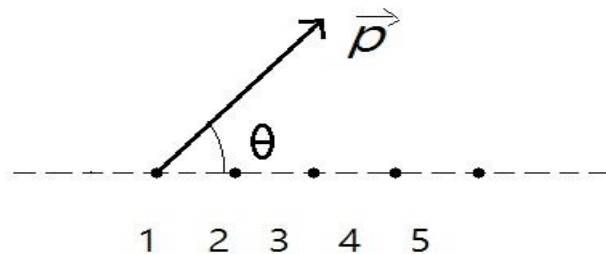

Fig 1.3 An ULA with $N = 5$ elements

To simplify the antenna array model and facilitate the signal processing two general simplifying assumptions are made.

The first assumption is called the far field assumption. Here the target is assumed to operate in the far field of the array. For targets in the far field of the array the direction of propagation for each antenna is approximately the same. Thus each antenna has to look in the same direction for the target. In fig 1.4, for the far field approximation to hold, for a distance d between the target and the antenna array of length $2r$ the ratio $\frac{d}{r}$ must be such that the incidence angles for each array

element lie within a desired range. Throughout this thesis we shall assume the targets to lie in the far field.

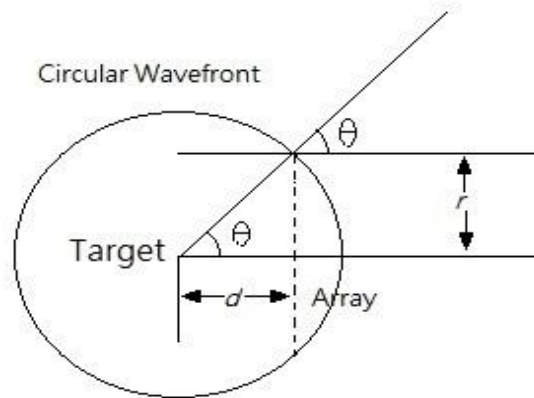

Fig 1.4 Far field approximation holds for proper values of the ratio $\frac{d}{r}$

The second approximation is regarding the bandwidth of the signal emitted. Using the narrowband approximation the time delay of the signal can be replaced by a simple phase shift. The amount of this phase shift is dependent on the center frequency at which the radar is operating.

Beamforming has been used in many diverse areas, including radar, sonar, medical imaging, seismology, wireless communications and speech processing. More detailed discussion on beamforming, in particular, beamforming in MIMO radar will be taken up in chapter 3.

1.3 Literature Review

MIMO radar research is a rapidly growing field. Lately there has been tremendous interest in MIMO radar signal processing and beamforming research. It would be very difficult to cover all

papers related to this interesting topic. However, in this section we attempt to review some of the important and related literature on MIMO radar beamforming.

One of the virtues attributed to MIMO radar is the spatial diversity offered by it. The Spatial diversity gain is even greater for the statistical MIMO radar. Fishler [9] and Lehmann et al. [12] discuss the advantages of spatial diversity offered by a MIMO radar. Dai et al. [13] propose some variations of this theme which allow closer spacing of the elements. These papers in general, discuss the improvement in parameter identifiability and fading mitigation because of the availability of multiple bistatic paths created by the widely separated transmit and receive elements.

In this project we have considered only the coherent MIMO radar system in which transmit and receive antennas are closely spaced [14]. References [8], [9] discuss the virtual array concept for MIMO radar and the degrees of freedom offered by MIMO radar. The construction of filled virtual arrays from given sparse transmit/receive arrays is the topic of discussion in [8]. For designing antenna array, for a given number of antennas, there is usually a tradeoff between sidelobe level, and aperture [11-12]. The threshold point is determined by the height of these sidelobes.

The SNR at which an estimator starts deviating from the Cramer–Rao bound is the threshold point.

This is shown in fig 1.5.

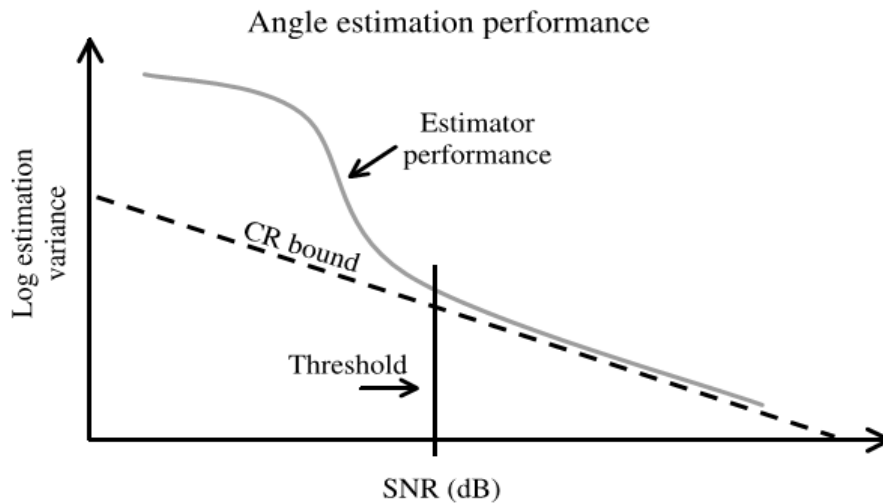

Fig 1.5 Angle estimation Performance

Beamforming is the process of steering a beam towards any direction in space [1], [2]. The problem of beampattern design in MIMO radar has been addressed in many ways. One approach is to optimize the weight vector associated with the transmit or the receive array [14]. Another common approach uses the signal covariance matrix to design the transmit beamforming.

In [15] it has been shown that transmit beamforming is equivalent to optimizing the signal cross correlation matrix \mathbf{R} of the transmitted signal vector. Optimizing the signal cross-correlation matrix \mathbf{R} can be modelled as a convex optimization problem [16]. It can also be modelled as a semi definite quadratic programming (SQP) problem [17], allowing the application of fast interior point methods for optimization. Some approaches for designing the signal cross-correlation matrix that don't require optimization are based on the singular value decomposition (SVD) [18]. Optimization of signal waveform correlation for particular channel realizations has been discussed by Forsythe and Bliss [10].

Generally there are two approaches for waveform design. The first approach considers the design of the time series being transmitted from each transmitter. In [6] and [11], time series are designed using simulated annealing and genetic algorithms, respectively, for better range estimation and cross-transmitter characteristics.

The second approach, which is the approach we take in this thesis, does not consider the details of the time series. Here, only the correlation between signals transmitted from the transmit elements is designed. Yang and Blum [28] model waveform optimization as maximizing the mutual information, using knowledge of the covariance structure of wide-sense-stationary target response. San Antonio and Fuhrmann [16] talk about optimization of wideband signals for illuminating a given area. A number of application areas have been discussed for MIMO radar. These include air-surveillance systems [9], clutter mitigation [12], airborne ground moving-target indication (GMTI) radar application [10].

The above represents only a snapshot of the current MIMO radar research as the MIMO radar literature is getting richer and richer every day. In the next section we provide the motivation for our project and discuss some of the advantages and applications of MIMO radar.

1.4 Motivation

MIMO radar has provided a new paradigm for signal processing research. The promising capabilities of a MIMO radar has drawn the attention of engineers and researchers throughout the globe. The waveform diversity in MIMO radar offers superior capabilities as compared to a standard phased array radar. Some of these are:

- Improved target detection capability

- Enhanced accuracy in angle estimation
- Lower minimum detectable velocity
- Direct applicability of adaptive algorithms
- Enhanced spatial diversity gain
- High degree of flexibility in designing beam pattern

One of the most important aspect of MIMO radar is the flexibility it offers in designing the transmit beam pattern. The transmit beamforming methods which are based on optimizing the signal covariance matrix can use different methods for optimization. Thus it very interesting research area to look for more accurate and faster optimization algorithms which give closed form solutions. Developing methods for real time beam pattern synthesis for tracking targets and generalizing the beam pattern synthesis algorithms for both narrow as well as wide band signals are areas in which much work remains to be done. Another interesting and highly worthy area to be explored is design of fixed cross-correlation constant modulus signals.

Thus from both mathematical as well as theoretical perspective, MIMO radar offers a highly interesting area of research and in the present thesis work we shall explore some of the methods and algorithms related to transmit beam pattern synthesis.. We shall be concerned only with the narrow band probing signals.

1.5 Thesis outline

This thesis covers mainly the transmit beamforming aspect of a MIMO radar system based on signal covariance matrix optimization. The thesis has been divided in to four chapters. In this section we briefly introduce the main contents of each chapter.

1.5.1 Chapter 1- Introduction

In this chapter we briefly introduce the basic concepts of radar and MIMO radar and also introduce the concept of beamforming in a radar system. We give an idea of the state of current MIMO radar research through a brief survey of relevant literature.

1.5.2 Chapter 2- MIMO radar: an overview

In this chapter we provide an overview of MIMO radar. Firstly, we provide a glossary of the important terms used in MIMO radar literature. We then discuss antenna arrays and introduce the multistatic radar concept. In this chapter we also discuss phased array radar where we talk about some important concepts related to phased array radar and develop the signal model for it. In section 2.5 we move on to MIMO radars. Here apart from introducing the concept of a virtual array, we also talk about coherent MIMO radar, develop a signal model for it and discuss the advantages offered by a MIMO radar as compared to its phased array counterpart.

1.5.3 Chapter 3- Transmit Beamforming in MIMO radar

In this chapter we briefly discuss the concept of beamforming in MIMO radar. We show in this chapter that transmit beamforming or beampattern matching problem is equivalent to optimizing the covariance matrix of the transmitted signal waveforms. We study some of the existing algorithms and obtain the simulation results in Matlab. In this chapter we also introduce a new beampattern design algorithm based on convex optimization. The simulation results for this algorithm are also presented.

1.5.4 Chapter 4- Conclusion and future work.

In this section we conclude our thesis and discuss prospects of future work.

1.6 Notations

In this thesis scalars are represented by small case letters (e.g. a). Matrices are represented using bold face capital letters (e.g. \mathbf{A}). Vectors are represented by bold face small case letters (e.g. \mathbf{a}). $\mathbf{a}(\theta)$ represents a vector parameterized by scalar θ . Superscripts T and H represent the transpose and transpose conjugate operators respectively. The expression $(\mathbf{A})_{i,j}$ represents the element located at the i^{th} row and the j^{th} column of a matrix \mathbf{A} . The trace of matrix \mathbf{A} is represented as $\text{tr}(\mathbf{A})$. S_+^N denotes the space of $N \times N$ symmetric Hermitian matrices. The notation \succeq is a matrix inequality operator, $\mathbf{A} \succeq \mathbf{B}$ if $\mathbf{A} - \mathbf{B}$ is positive definite. Notation $E[\bullet]$ denotes the expectation operator.

Chapter 2

MIMO radar: an overview

In this chapter we provide an overview of MIMO radar. This chapter is divided into sections. Section 2.1 provides a glossary of the important terms used in MIMO radar literature. We discuss antenna arrays in section 2.2. In section 2.3 multistatic radar concept is introduced, here we discuss briefly the working of multistatic radars and the advantages they offer. Section 2.4 deals with phased array radar. In this section we talk about some important concepts related to phased array radar develop the signal model for it. In section 2.5 we move on to MIMO radars. Here apart from introducing the concept of a virtual array, we also talk about coherent MIMO radar, develop a signal model for it and discuss the advantages offered by a MIMO radar as compared to its phased array counterpart.

2.1 Glossary of important terms

SIMO: Single Input Multiple Output is a radar system that has a single transmit and multiple receive elements.

MISO: Multiple Input Single Output is a radar systems that has multiple transmit elements and a single receive elements.

MIMO: A MIMO radar system has multiple transmit and multiple receive elements.

Point Target (Scatterer): A point target is one that has small largest physical dimension compared to the size of the radar resolution cell in range, angle or both [1],[7].

Distributed Target (Scatterer): A Distributed Target has its largest dimensions large relative to the radar resolution cell is called distributed target [7].

Extended Target (Scatterer): An extended Target occupies more than one resolution cell.

Uniform Linear Array (ULA): In an ULA the separation between the elements is uniform and they are spaced along a straight line.

Filled array: In case of filled array the array elements are half wavelength apart.

Sparse array: In case of sparse array the array elements are more than half wavelength apart.

2.2 Antenna array

Faint signals can be detected much better by bigger antennas than by smaller ones. But it is mechanically very difficult to handle such big antennas. One way around this problem is to use many smaller antennas. In case of an antenna array the output from these multiple antennas is combined to enhance the total received signal. Such an antenna array offers many advantages over single large antenna. The signals can be weighted before combining them to improve performance features like interference rejection and steering the beam without the need to physically move the

antenna. It even becomes possible to design an antenna array that has the capability to adapt its performance to better suit its environment. We have to pay for these attractive features in the form of increased complexity and cost.

2.3 Multistatic radar system

Such radar systems that have more than one transmitting or receiving antennas. Usually in a multistatic radar system antennas are separated by large distances in comparison to the antenna sizes. There is not one single definition of multistatic radar. Fig 2.1 and Fig 2.2 show two configurations of multistatic radar system. In fig 2.1 a multistatic radar system is shown that has only one transmit element and multiple spatially separated receive elements.

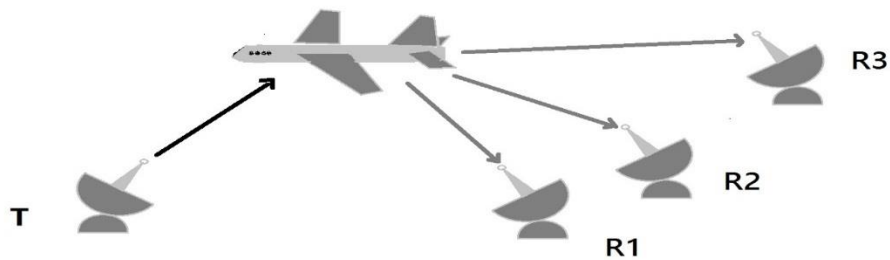

Fig 2.1 Multistatic radar system (Single transmit element and multiple receive elements)

Fig 2.2 shows another configuration of multistatic radar system that has spatially separated radars which operate in bistatic mode.

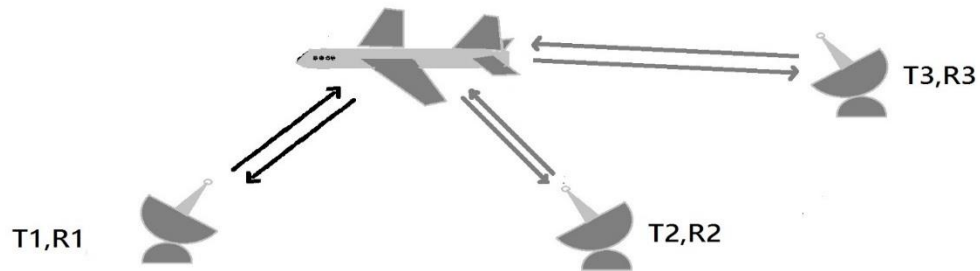

Fig 2.2 Multistatic radar system (spatially separated radars operating in bistatic mode)

In case of multistatic radar systems, each transmit receive antenna pair may act as individual radar. Each transmit receive pair may process the received signals separately and the outputs are combined together in a central processing center.

The multistatic radar systems offer many advantages [5]. With extra transmitter and receiver units there is an increase in the total power and sensitivity of the system and a decrease in the losses in signal power. Other advantages of multistatic radar systems include highly accurate estimation of position of a target, enhanced resolution capability and resistance to jamming.

2.4 Phased Array Radar

Phased Array Radar uses uniform linear arrays for transmitting and receiving signals. In case of phased array radar each antenna is allowed to transmit only scaled versions of the same waveform.

Fig 2.3 shows a simple phased array radar.

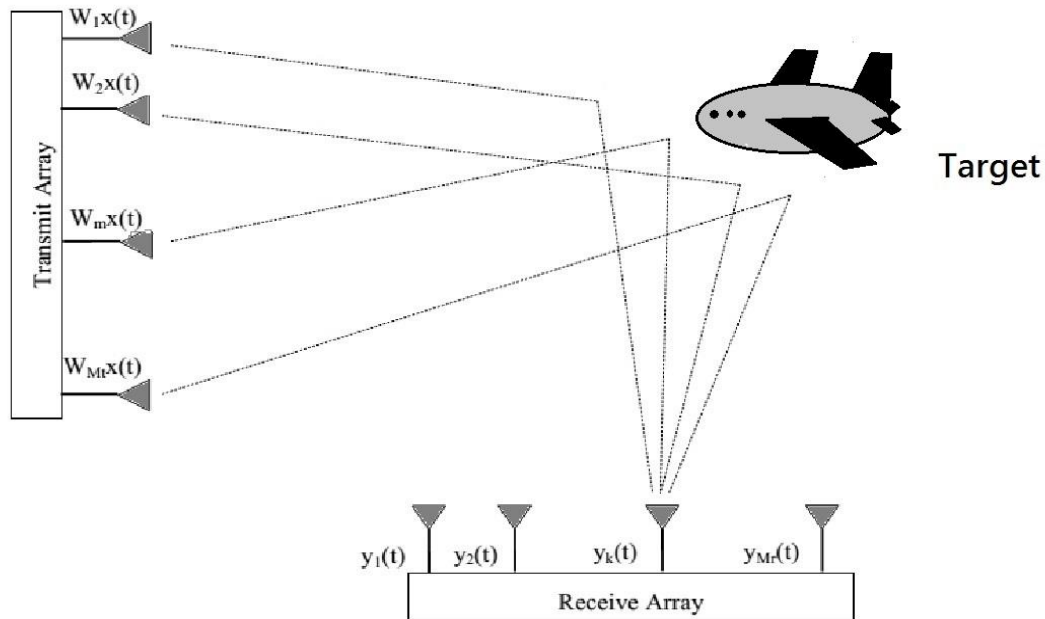

Fig 2.3 Illustration of a phased array radar

Usually the transmit elements in a phased array radar are omnidirectional but by properly adjusting the weights (scale factor) associated with each element we can obtain high degree of directionality. By adjusting these weights we can steer a beam towards any direction in space. This is called beamforming [1]. Since the phased array radars have the ability to steer the beam electronically, they are also known as beamformers.

For a large enough number of elements in an array multiple independent beams may be steered at once. These multiple beams can search different sectors of the space or track multiple targets simultaneously [5]. These operations can also be carried out on a time sharing basis by a single radar system permitting the use of phased array radar for multi-tasking [5]. However these advantages come at the price of increased complexity and cost.

2.4.1 Signal Model

Consider a phased array radar system with M_t transmitting and M_r receiving elements. If these are collocated then $M_t = M_r$. Let each transmit element transmit a narrow band signal $s(t)$. Then under the far field approximation, we can write the output of the transmitter which is forming a beam in the direction $\hat{\theta}$ as

$$\mathbf{x}(t) = \mathbf{a}(\hat{\theta})s(t) \quad (2.1)$$

Here $\mathbf{a}(\hat{\theta})$ is the steering vector associated with the transmitter. The steering vector represents the phase delays associated with each transmit-receive pair. The steering vector $\mathbf{a}(\hat{\theta})$ can be written as

$$\mathbf{a}(\hat{\theta}) = \begin{bmatrix} 1 \\ e^{j2\pi d \sin \theta / \lambda} \\ \vdots \\ e^{j2\pi d (M_t - 1) \sin \theta / \lambda} \end{bmatrix} \quad (2.2)$$

Here λ is the carrier wavelength of the radar.

For a stationary target in the far field of the antenna array located in a direction θ , the total signal at the target location, assuming a non-dispersive propagation can be given as

$$\begin{aligned} x^t(t) &= \mathbf{a}^H(\theta) \mathbf{x}(t - \tau_t) \\ &= \mathbf{a}^H(\theta) \mathbf{a}(\hat{\theta}) s(t - \tau_t) \end{aligned} \quad (2.3)$$

$\mathbf{a}(\theta)$ is defined as in (2.2) with $\hat{\theta}$ replaced by θ . τ_t is the time taken by a signal transmitted at receiver to reach the target. Assuming that the transmit and receive elements are collocated and each transmit-receive pair experience the same back scattering β we can write the signal at the receiver as

$$\mathbf{y}^r(\mathbf{t}) = \beta \mathbf{b}(\theta) \mathbf{a}^H(\theta) \mathbf{a}(\hat{\theta}) s(\mathbf{t} - \tau) + \mathbf{e}(\mathbf{t}) \quad (2.4)$$

Where τ is the total time taken from the transmitter to the receiver ($\tau = \tau_r + \tau_t$) and $\mathbf{b}(\theta)$ is given as

$$\mathbf{b}(\theta) = \begin{bmatrix} 1 \\ e^{-j2\pi d \sin \theta / \lambda} \\ \vdots \\ e^{-j2\pi d (M_r - 1) \sin \theta / \lambda} \end{bmatrix} \quad (2.5)$$

$\mathbf{e}(t)$ is a vector of noise signals and can be represented as

$$\mathbf{e}(\theta) = \begin{bmatrix} e_1(t) \\ e_2(t) \\ \vdots \\ e_{N_r}(t) \end{bmatrix} \quad (2.6)$$

2.4.2 Beamforming in phased array radar

In this section we will discuss the use of phased array radar as a beamformer. Consider the vector model $\mathbf{x}(t) = \mathbf{a}(\theta)s(t)$. This gives the array output vector as a function of time. This output vector

depends upon the signal and the response of the array to the signal. To form a beam we need a beamformer which produces the weighted sum given as

$$\begin{aligned}
 y(t) &= \mathbf{w}^H \mathbf{x}(t) \\
 &= \mathbf{w}^H \mathbf{a}(\theta) s(t) \\
 &= G(\theta) s(t)
 \end{aligned} \tag{2.7}$$

Here $G(\theta) = \mathbf{w}^H \mathbf{a}(\theta)$ is the gain of the beamformer and \mathbf{w} represents the beamforming weight vector. Fig 2.4 shows such a beamformer.

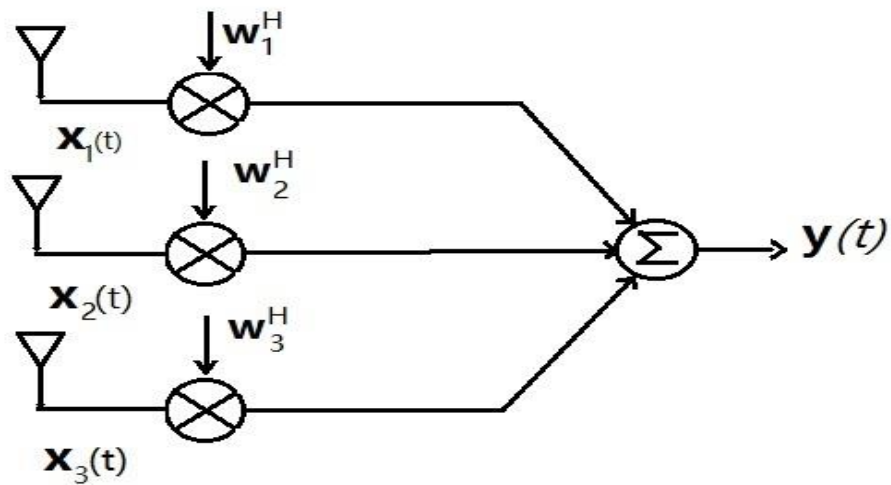

Fig 2.4 A three-element beamformer

By properly designing the beamformer weight vector we can steer the beam in the desired direction.

2.5 MIMO radar

MIMO Radar has multiple transmit and receive elements for transmitting and receiving signals. These antennas can be either closely spaced or can be widely spaced.

Each transmit element in a MIMO radar system is allowed to transmit different waveforms unlike a phased array radar where every antenna can transmit only scaled versions of same waveform. These waveforms are usually orthogonal, and can have any degree of correlation between them.

This waveform diversity offered by a MIMO radar is one of the most important properties of MIMO radar. Synthesizing mutually orthogonal signal waveforms that have desired autocorrelation and crosscorrelation properties is subject of much interest [9], [19]. In this thesis we discuss MIMO radar with collocated antennas.

MIMO radar offers higher resolution [20], enhanced ability to detect slowly moving targets [11], improved parameter identifiability [11], and direct applicability of adaptive techniques [20]. The flexibility offered by MIMO radar in designing transmit beampattern is one of the distinguishing feature of MIMO radar. We look at these features at the end of this section. Fig 2.5 illustrates a basic MIMO radar configuration as compared to that of a phased array radar.

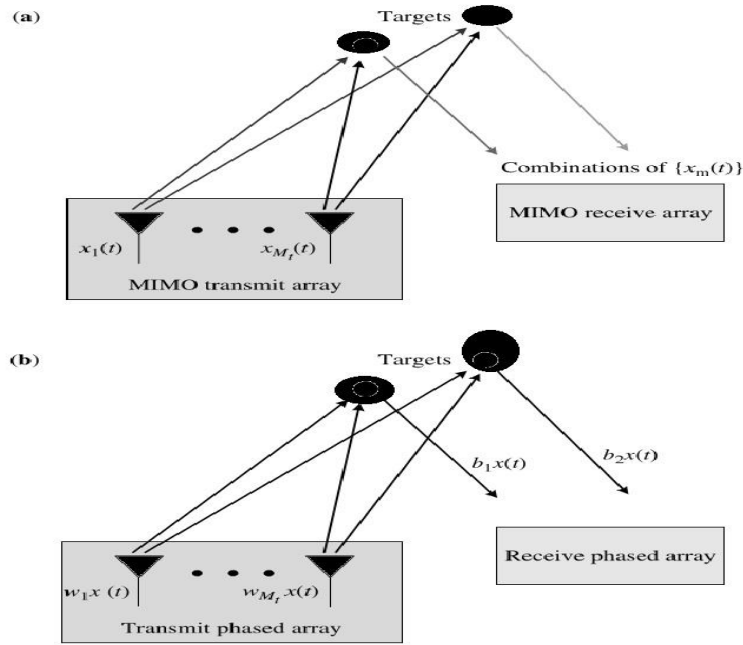

Fig 2.5 (a) MIMO radar vs (b) Phase array radar

The degrees of freedom offered by MIMO radar can be significantly improved by using the concept of virtual arrays. In following sections we first introduce the MIMO channel and then move on to discuss MIMO radar virtual arrays.

2.5.1 MIMO channel

The channel exists between the transmitter and receiver. One aim of radar signal processing is to estimate the parameters of this channel. A base band sampled signal is considered with N_s number of samples in each block. For N_t transmit elements at the transmitter and N_r receive elements at the receiver the $N_r \times N_s$ received data matrix \mathbf{Z} is given by

$$\mathbf{Z} = \sum_{\delta} \mathbf{H}_{\delta} \mathbf{S}_{\delta} + \mathbf{N} \quad (2.8)$$

Where \mathbf{H}_δ is the $N_r \times N_t$ complex channel matrix for delay δ and the complex matrix \mathbf{S}_δ is the $N_t \times N_s$ transmitted signal matrix delayed by time δ .

If the region of interest contains a single simple scatterer in the far field of the array at a delay δ , then the channel matrix would be zero at all delays except at δ . \mathbf{H}_δ in this case has a structure

$$(\mathbf{H}_\delta)_{n,m} \propto e^{j\mathbf{k}\mathbf{u}(\mathbf{y}_n + \mathbf{x}_m)} \quad (2.9)$$

Where $k\mathbf{u}$ the wave is vector and \mathbf{x}_m , \mathbf{y}_n are the location vectors for the transmitter and receiver phase centers, respectively.

2.5.2 MIMO virtual array

The concept of virtual arrays allows to have a substantial increase in the effective aperture and to control sidelobe levels. Eq. (2.9) shows that the MIMO radar appears to have phase centers at the virtual locations $\{\mathbf{y}_n + \mathbf{x}_m\}$. Thus we can say that the MIMO virtual array phase centers can be given by the convolution of the real transmitter and real receiver locations. We discuss the virtual array concept for a collocated MIMO radar where transmit and receive elements are constrained to occupy the same locations. For simplicity, the sparse arrays phase centers are assumed to be selected from a one-dimensional lattice with $\lambda/2$ spacing. The length of the MIMO virtual array is computed in terms of the number of phase centers present in the physical array.

For example consider a sparse array of eight elements given as

$$\{1 \ 1 \ 0 \ 1 \ 0 \ 1 \ 0 \ 1 \ 0 \ 1 \ 0 \ 1 \ 1\}$$

If this sparse array is used for both transmitter and receiver, one gets the following filled MIMO virtual array

{ 1 2 1 2 2 2 3 2 4 2 5 2 8 2 5 2 4 2 3 2 2 2 1 2 1 }

Here we used an eight element sparse array to produce a filled array on 25 apertures. Hence much larger virtual apertures of length $2N - 1$ can be obtained using N element sparse array. In the next chapter we introduce transmit beamforming for MIMO radar. We discuss some of the existing algorithms for beampattern synthesis and also introduce the work done in the present project.

2.5.3 Improvements offered by MIMO radar

MIMO radar offers enhanced performance in various application fields over a standard phased array radar by the virtue of its waveform diversity. This diversity of waveform introduces more degrees of freedom and is the key to performance improvement in many of the MIMO radar applications. In this section we consider some of these improvements.

2.5.3.1 Higher Resolution

For a radar system the resolution increases for larger effective apertures. In case of MIMO radars, we showed that the concept of virtual arrays allows us to design a filled virtual array of size much larger than the sparse physical array. So MIMO radar can have much larger effective aperture and hence higher resolution

2.5.3.2 Parameter identifiability

Parameter identifiability of a radar refers to the maximum number of targets that the radar can identify uniquely. The waveform diversity in case of MIMO radar offers a much improved parameter identifiability compared to its phased-array counterpart. In [21] it has been shown that the maximum number of targets K_{max} that can be identified uniquely by a MIMO radar lies in the range

$$K_{max} \in \left[\frac{2(M_t + M_r) - 5}{3}, \frac{2M_t M_r}{3} \right) \quad (2.10)$$

For a phased array radar, for which all the parameters are same as the MIMO radar except that $M_t = 1$,

$$K_{max} \leq \frac{2M_r - 3}{3} \quad (2.11)$$

Comparing (2.10) and (2.11), we note that parameter identifiability in MIMO radar can be up to M_t times better than phased array counterpart.

2.5.3.3 Transmit Beampattern Synthesis

The beampattern for individual transmit elements of a coherent MIMO radar system is usually omnidirectional. This waveform diversity prevents MIMO radars from having high directivity of phased array radars. Despite this shortcoming, it is still possible generate a desired beampattern, by using different signals in every transmit element [15], [16] and [17]. We will discuss this aspect of MIMO radar in the next chapter.

Chapter 3

Transmit Beamforming in MIMO radar

Transmit beamforming in MIMO radar is the theme of this thesis. This chapter focuses on beamforming algorithms. We briefly introduced beamforming in Chapter 1. The beampattern for individual transmit elements of a coherent MIMO radar system is usually omnidirectional. This waveform diversity prevents MIMO radars from having high directivity of phased array radars. In spite of this shortcoming, it is still possible to generate a desired beampattern, by using different signals in every transmit element [15], [16] and [22]. In the next sections we show how the problem of transmit beampattern synthesis is equivalent to optimizing the covariance matrix of the transmitted signal waveforms. We study some of the existing algorithms and obtain the simulation results in Matlab. In this chapter we also introduce a new beampattern design algorithm based on convex optimization.

3.1 Problem Formulation

Assume a MIMO radar with M collocated, narrowband transmit/receive antennas. These elements form a uniform linear array (ULA) with $\lambda/2$ spacing between them. Each transmitted signal pulse has N samples. In this thesis the transmit/receive antennas are assumed to lie along the z -axis as shown in fig. 3.1

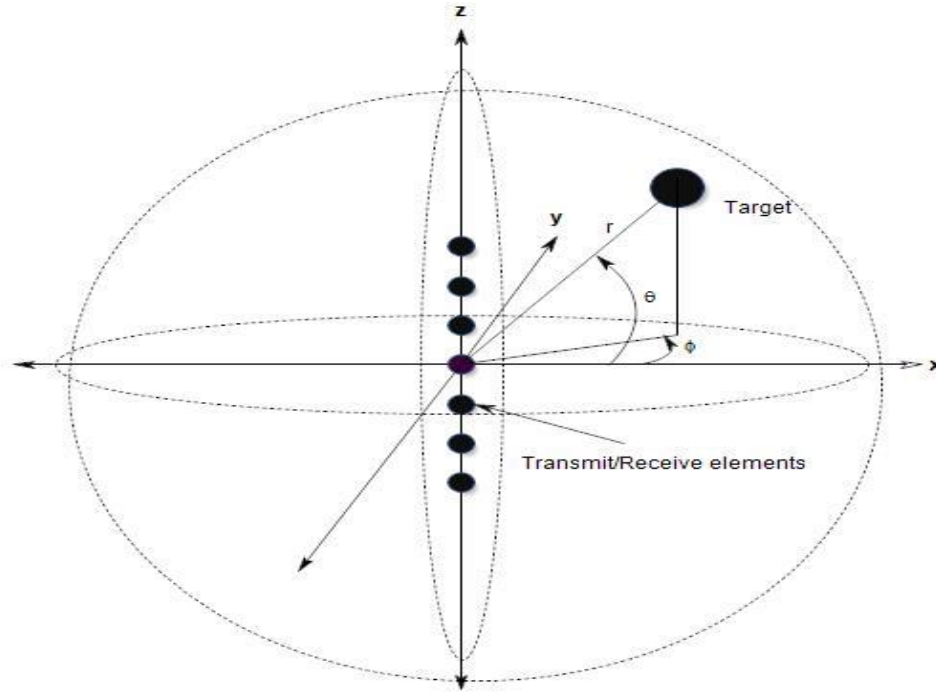

Fig. 3.1 Transmit/Receive elements and spherical coordinates

The i th element of the array is driven by a signal $x_i(n)$ so that the signal vector is given as

$$\mathbf{x}(n) = [x_1(n) \quad \dots \quad x_M(n)]^T \quad (3.1)$$

For nondispersive propagation, the baseband signal at the target location having target location θ can be given as []

$$\sum_{i=1}^M e^{-j2\pi f_o \tau_i(\theta)} x_i(\mathbf{n}) = \mathbf{a}^H(\theta) \mathbf{x}(\mathbf{n}) \quad n=1, \dots, N \quad (3.2)$$

Here f_o is the carrier frequency of the radar and $\tau_i(\theta)$ is the time a signal emitted from i th element takes to reach the target. For $\lambda/2$ spacing between the elements, the array steering vector $\mathbf{a}(\theta)$ is given as

$$\mathbf{a}(\theta) = [1 \quad e^{j\pi \sin(\theta)} \quad e^{j2\pi \sin(\theta)} \quad \dots \quad e^{j(N-1)\pi \sin(\theta)}] \quad (3.3)$$

Using (2) we can write the probing signal power at location θ as

$$P(\theta) = E\{|\mathbf{a}^H(\theta)\mathbf{x}(n)|^2\} = \mathbf{a}^H(\theta)\mathbf{R}\mathbf{a}(\theta) \quad (3.4)$$

where \mathbf{R} is the signal covariance matrix given by the expression

$$\mathbf{R} = E\{\mathbf{x}(n)\mathbf{x}^H(n)\} \quad (3.5)$$

The signal power pattern in (3.4) as a function of θ is the transmit beampattern we want to synthesize [15]. In this thesis we focus on generating the covariance matrix \mathbf{R} . Once \mathbf{R} obtained the transmitted signal vector which has a covariance matrix very close to \mathbf{R} can be generated, a problem which is the topic of future work and that we don't consider in this thesis. In the following section we show with an example how we can generate a beampattern using the matrix \mathbf{R} .

3.2 Example

Assume that signal cross-correlation matrix \mathbf{R} is an $M \times M$ real Toeplitz matrix parameterized by ρ , $0 \leq \rho \leq 1$, of the following form

$$\mathbf{R} = \begin{bmatrix} 1 & \rho & \dots & \rho^{M-1} \\ \rho & 1 & & \vdots \\ \vdots & & \ddots & \\ \rho^{M-1} & \dots & & 1 \end{bmatrix} \quad (3.6)$$

Where N is the number of TX/RX.

When $\rho = 1$, then the signals are perfectly coherent and this corresponds to a phased array radar.

When $\rho = 0$, then the signals are mutually uncorrelated (isotropic case). For values of ρ between 0 and 1, the signals are partially correlated. Fig 3.2 shows the beampattern obtained for different values of ρ .

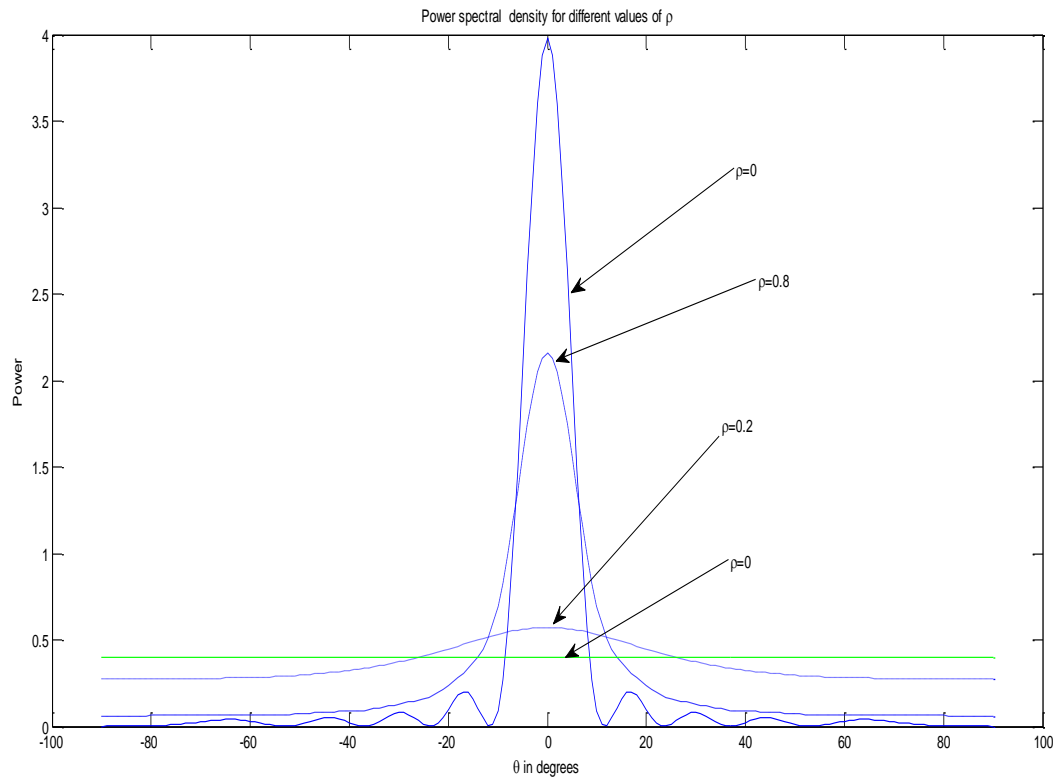

Fig 3.2. Beampattern obtained for different values of ρ

3.4 Transmit Beampattern Synthesis

By synthesizing the proper covariance matrix for the transmitted signal [15], we can

- (a). maximize the total spatial power at known target locations and minimize it elsewhere.
- (b). approximate a desired beampattern
- (c). achieve a predetermined 3 dB main beamwidth and minimize the sidelobe levels.

A number of algorithms have been proposed to design the covariance matrix to meet one or more of these goals. Most of these methods require optimization. Once the covariance matrix has been obtained, signal waveforms can be generated to have a covariance matrix which is very close to the one obtained.

3.4.1 Existing methods

In this section we take a look at some of the existing methods and algorithms [15-23] to obtain the required signal covariance matrix.

To approximate a given beampattern, Fuhrman [15] offers an algorithm based on gradient search without any elemental power constraint. However, this method doesn't control the cross-correlation beampattern. So the signals echoed back to the radar may be fully coherent and adaptive array processing techniques cannot be used.

In [17], an algorithm using Semi Definite Quadratic Programming (SQP) to match a required beampattern while controlling the cross-correlation beampattern over the sectors of interest under the uniform elemental transmit power constraint has been proposed.

An algorithm based on Singular Value Decomposition (SVD) has been proposed in [18] to synthesize the required covariance matrix. This method doesn't require optimization.

3.5 Proposed method

In this section we address the problem of designing the covariance matrix \mathbf{R} to match a desired beampattern. Firstly we propose an algorithm for transmit beampattern synthesis where the optimization problem is rewritten in the form of an unconstrained SDP problem. We use two cost functions namely 2-norm and the infinity norm based on which we generate the covariance matrix \mathbf{R} . In the second algorithm we propose a method for beamforming which minimizes the cross correlation beampattern as well as keeps the sidelobe levels below a certain threshold. In first algorithm beampatterns are synthesized based on total transmitted power constraint so that

the power transmitted from individual elements can be varied. In the second algorithm we consider uniform elemental power constraint while designing the beampattern.

3.5.1 Beampattern matching algorithm

Let $\phi(\theta)$ be the desired beampattern to be designed. Let the angle interval $[-\pi/2, \pi/2]$ be divided into K fine grid of points denoted by $\theta_k \in \Theta, (k = 1, \dots, K)$. The aim of beampattern matching design is to generate a beampattern that closely approximates the desired beampattern. In this thesis we use the following two cost functions namely the 2-norm and the infinity norm:

$$J_2(\alpha, \mathbf{R}) = \sum_{k=1}^K |\alpha\phi(\theta_k) - \mathbf{a}^H(\theta_k)\mathbf{R}\mathbf{a}(\theta_k)|^2 \quad (6)$$

$$J_\infty(\alpha, \mathbf{R}) = \max_{\theta_k} |\alpha\phi(\theta_k) - \mathbf{a}^H(\theta_k)\mathbf{R}\mathbf{a}(\theta_k)| \quad (7)$$

Instead of assuming a uniform elemental power constraint, in our design problem we consider the total transmit power constraint. This allows us to vary the individual transmitted powers depending upon the sensing application. This means that the covariance matrix \mathbf{R} must satisfy the following two constraints:

- (a) $\text{tr}(\mathbf{R}) \leq c$, the total transmitted power constraint, where c is the maximum power available for transmission
- (b) $\mathbf{R} \succeq \mathbf{0}$, i.e. \mathbf{R} must be a positive semidefinite matrix.

Thus we can write the design problem mathematically as:

A. 2-norm minimization

$$\begin{aligned}
& \min_{\alpha, \mathbf{R}} \sum_{k=1}^K (|\alpha\phi(\theta_k) - \mathbf{a}^H(\theta_k) \mathbf{R} \mathbf{a}(\theta_k)|^2) \\
& \text{s.t.} \quad \text{tr}(\mathbf{R}) \leq c \\
& \quad \quad \mathbf{R} \succeq \mathbf{0}
\end{aligned} \tag{8}$$

Now, we will show that the optimization problem (8) can be reformulated as an unconstrained SDP problem []. To do so, we define a new variable d where

$$d = c - \text{tr}(\mathbf{R}) \tag{9}$$

For the inequality $\text{tr}(\mathbf{R}) \leq c$ to hold, d must be nonnegative i.e. $d \geq 0$. We define a matrix $\hat{\mathbf{R}}$ as

$$\hat{\mathbf{R}} = \begin{bmatrix} \mathbf{R} & \mathbf{0} \\ \mathbf{0} & d \end{bmatrix} \tag{10}$$

Since the sum of Eigen values of a matrix equals the trace of the matrix so if \mathbf{R} is positive semidefinite then $\hat{\mathbf{R}}$ can be positive semidefinite if and only if $d \geq 0$. Thus the constraint $\hat{\mathbf{R}} \succeq \mathbf{0}$ automatically satisfies the total power constraint $\text{tr}(\mathbf{R}) \leq c$. Thus we can reformulate the optimization problem in (8) as

$$\begin{aligned}
& \min_{\alpha, \hat{\mathbf{R}}} \sum_{k=1}^K (|\alpha\phi(\theta_k) - \hat{\mathbf{a}}^H(\theta_k) \hat{\mathbf{R}} \hat{\mathbf{a}}(\theta_k) + d^2|^2) \\
& \text{s.t.} \quad \hat{\mathbf{R}} \succeq \mathbf{0}
\end{aligned} \tag{11}$$

where $\hat{\mathbf{a}}(\theta_k)$ is given as $\hat{\mathbf{a}}(\theta_k) = [\mathbf{a}(\theta_k) \quad 1]^T$. This optimization problem has the form of an unconstrained SDP problem that can be solved using convex optimization toolbox CVX [24-27].

B. Infinity-norm minimization

$$\begin{aligned} \min_{\alpha, \mathbf{R}} \max_{\theta_k} & \quad | \alpha \phi(\theta_k) - \mathbf{a}^H(\theta_k) \mathbf{R} \mathbf{a}(\theta_k) | \\ \text{s.t.} & \quad \text{tr}(\mathbf{R}) \leq c \\ & \quad \mathbf{R} \succeq \mathbf{0} \end{aligned} \tag{12}$$

Using the approach used for 2-norm minimization we can reformulate this problem as

$$\begin{aligned} \min_{\alpha, \hat{\mathbf{R}}} \max_{\theta_k} & \quad | \alpha \phi(\theta_k) - \hat{\mathbf{a}}^H(\theta_k) \hat{\mathbf{R}} \hat{\mathbf{a}}(\theta_k) + d^2 | \\ \text{s.t.} & \quad \hat{\mathbf{R}} \succeq \mathbf{0} \end{aligned} \tag{13}$$

which is again an SDP problem and can be solved using CVX.

3.5.2 Beampattern matching algorithm with cross correlation beampattern and sidelobe considerations

The performance of adaptive algorithms in MIMO radar is greatly dependent on the cross correlation beampattern $\mathbf{a}^H(\theta) \mathbf{R} \mathbf{a}(\bar{\theta})$ between the signals at locations θ and $\bar{\theta}$ [20]. This performance deteriorates with increasing cross correlation. Thus one aim of the transmit beamforming should be to minimize the cross correlation beampattern. Another desired attribute of a beampattern design algorithm is its ability to control the sidelobe levels. In this section we propose an algorithm in which we try to address these two issues.

We have assumed a fine grid of points $\theta_k \in \Theta$, ($k=1, \dots, K$) cover the region of space under consideration ($-\pi/2 \leq \theta \leq \pi/2$). The set Θ can be further divided in to two subsets: the main lobe Θ_M and the side lobe Θ_S . The θ_k 's that belong to Θ_M are represented as θ_m ($m = 1, \dots, \bar{M}$) and those belonging to Θ_S are represented as θ_s ($s = 1, \dots, S$). Our aim is to optimize the covariance matrix \mathbf{R} such that:

- (a) In the main lobe region the designed beampattern matches the desired one while in the sidelobe region it remains below a given threshold.
- (b) The cross correlation beampattern $\mathbf{a}^H(\theta)\mathbf{R}\mathbf{a}(\bar{\theta})$ between the signals at locations θ and $\bar{\theta}$ is minimized in the mainlobe region ($\theta \neq \bar{\theta}$).

Mathematically, this problem can be formulated as

$$\begin{aligned}
 \min_{\alpha, \mathbf{R}} & \left\{ \sum_{k=1}^K (|\alpha\phi(\theta_k) - \mathbf{a}^H(\theta_k)\mathbf{R}\mathbf{a}(\theta_k)|) + \sum_{k=1}^{K-1} \sum_{p=k+1}^K |\mathbf{a}^H(\theta_k)\mathbf{R}\mathbf{a}(\theta_p)| \right\} \\
 \text{s.t.} & \quad |\mathbf{a}^H(\theta_s)\mathbf{R}\mathbf{a}(\theta_s)| \leq \xi \\
 & \quad \theta_s \in \Theta_s, s = 1, \dots, S \\
 & \quad \mathbf{R}_{mm} = c / M \\
 & \quad \mathbf{R} \succeq \mathbf{0}
 \end{aligned} \tag{14}$$

Where ξ is the desired threshold for the sidelobe levels. In most of the practical scenarios we usually want to minimize the cross-correlation only in the main lobe regions. Thus a modification of problem (14) where we want a distortionless beampattern with minimum cross correlation in the

mainlobe region while the sidelobes remain below a threshold value will also be considered where the cross correlation is minimized only in the mainlobe regions instead of the entire angle interval $[-\pi/2, \pi/2]$.

$$\begin{aligned}
& \min_{\alpha, \mathbf{R}} \left\{ \sum_{m=1}^{\bar{M}} (|\alpha\phi(\theta_m) - \mathbf{a}^H(\theta_m)\mathbf{R}\mathbf{a}(\theta_m)|) + \sum_{k=1}^{\bar{M}-1} \sum_{p=k+1}^{\bar{M}} |\mathbf{a}^H(\theta_m)\mathbf{R}\mathbf{a}(\theta_m)| \right\} \\
& \theta_m \in \Theta_M, m = 1, \dots, \bar{M} \\
& \text{s.t.} \quad |\mathbf{a}^H(\theta_s)\mathbf{R}\mathbf{a}(\theta_s)| \leq \xi \\
& \theta_s \in \Theta_s, s = 1, \dots, S \\
& \mathbf{R}_{mm} = c/M \\
& \mathbf{R} \succeq \mathbf{0}
\end{aligned} \tag{15}$$

This design problem tries to meet the two conditions (a) and (b) stated above and can be solved for optimum \mathbf{R} using Matlab based toolbox CVX.

3.6 Simulation results

In this section simulation results for the proposed algorithm are provided to demonstrate their efficiency. For simulations we assumed a MIMO radar with a uniform linear array (ULA) of $M = 10$ elements with half wavelength spacing between them. Transmit and receive elements are collocated. We set the total transmit power c equal to one for our simulations.

For the region $\theta \in [-\pi/2, \pi/2]$, the desired beampattern is given as

$$\phi(\theta) = \begin{cases} 1, & \theta \in [\hat{\theta}_k - \Delta, \hat{\theta}_k + \Delta] \\ 0, & \text{otherwise} \end{cases} \tag{16}$$

Where $\hat{\theta}$ is the location of a target of interest. 2Δ is the beamwidth for each target location. We have taken $\Delta = 20^\circ$ for our case.

Fig.3.3 shows the beampattern synthesized using the first algorithm under 2-norm criterion. It can be seen from the plot that in the mainlobe region it closely matches the desired beampattern. Fig.3.4 shows the beampattern obtained under minimax criterion.

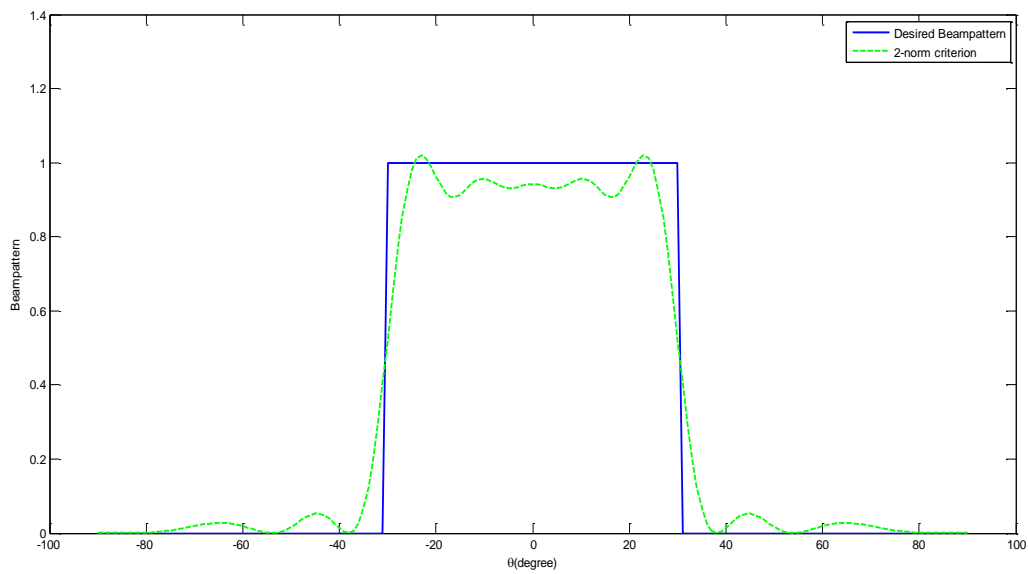

Fig. 3.3 Beampattern designed with 2-norm criterion

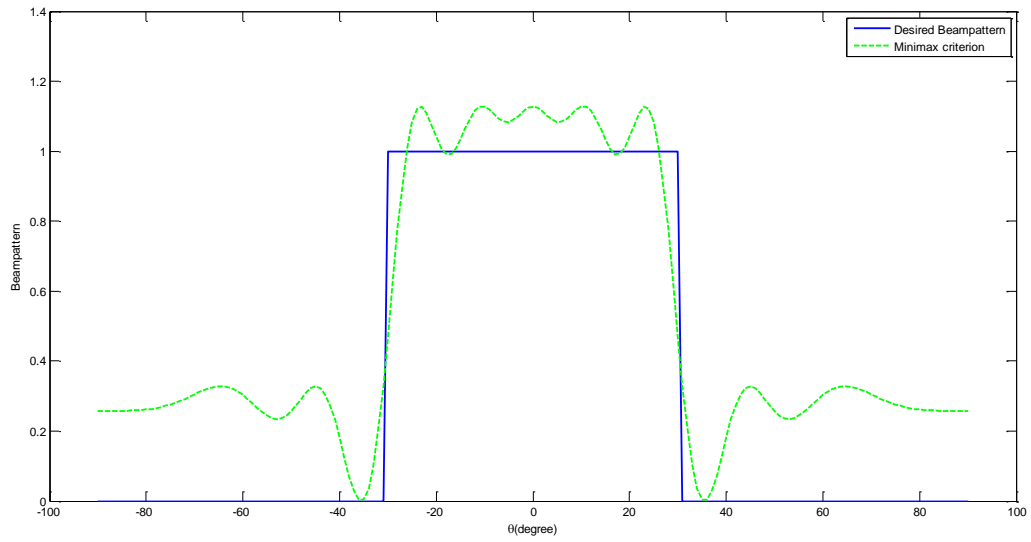

Fig. 3.4 Beampattern designed with minmax criterion

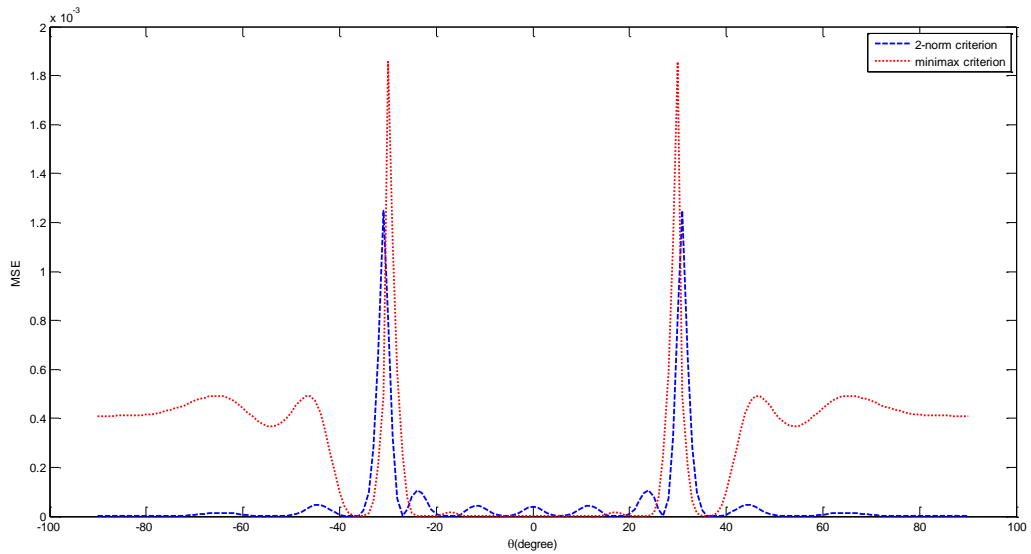

Fig. 3.5 Mean square error comparison for 2-norm and minimax criterion

From the plot we see how the obtained beampattern depends on the choice of the cost unction. Next we design the beampattern using the second algorithm under uniform elemental power constraint. Fig. 3.5 shows the beampattern obtained using algorithm 2.

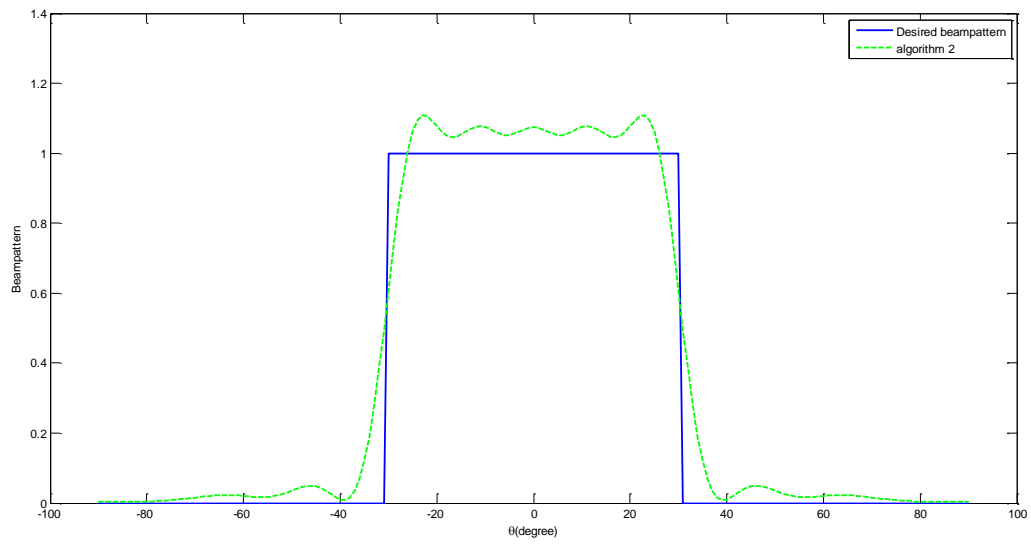

Fig. 3.6 Beampattern designed with algorithm 2 for minimum cross correlation beampattern and sidelobe control.

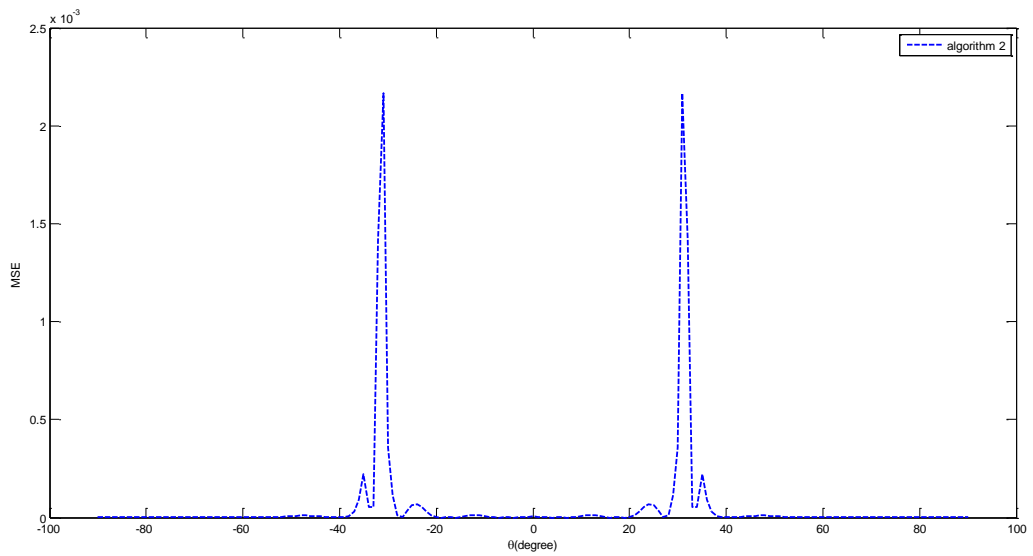

Fig. 3.7 Mean square error for algorithm 2

Chapter 4

Conclusion and Future Work

4.1 Conclusion

In this thesis, we provided an overview of MIMO radar and discussed some of the advantages offered by it. We mainly focused on transmit beamforming in MIMO radar. Two new algorithms for MIMO radar transmit beamforming based on signal covariance matrix optimization were proposed in this thesis.

In the first algorithm we propose a method to match a desired beampattern by modelling the design problem as an unconstrained semidefinite programming (SDP) problem based on the total power constraint. This total power constraint enables us to vary the individual transmitter powers to suit the sensing application. In the second algorithm we propose a method for beampattern matching under elemental power constraint such that the following two requirements are met

- (a) In the main lobe region the designed beampattern matches the desired one while in the sidelobe region it remains below a given threshold.
- (b) The cross correlation beampattern between the signals at locations θ and $\bar{\theta}$ is minimized in the mainlobe region ($\theta \neq \bar{\theta}$).

Simulation results are provided for the proposed algorithms for designing the waveform covariance matrix and they demonstrate the efficiency of these algorithms.

4.2 Future Work

Our future work will focus on developing methods for real time beam pattern synthesis for tracking targets and generalizing the beam pattern synthesis algorithms for both narrow as well as wide band signals. Another interesting area we wish to explore is design of fixed cross-correlation constant modulus signals.

References

- [1] M. Skolnik, "Introduction To Radar Systems", 3rd ed. McGraw-Hill, 2001
- [2] M.A. Richards, "Fundamentals of Radar Signal Processing", McGraw-Hill, 2005
- [3] C.C. Cook, M. Bernfeld, "Radar Signals: An Introduction To Theory and Application", Artech House, 1993
- [4] S.M. Kay, "Fundamentals Of Statistical Signal Processing Estimation Theory", Prentice Hall, 1998
- [5] V.S. Chernyak, "Fundamentals of Multisite Radar Systems : Multistatic Radars and Multiradar Systems", Gordon and Breach Science Publishers, 1998
- [6] N. Levanon, E. Mozeson, "Radar Signals", Wiley, 2004
- [7] IEEE Aerospace and Electronic Systems Society, IEEE Std 686-2008 IEEE Standard Radar Definitions, 2008
- [8] J. Li, P. Stoica, "MIMO Radar Signal Processing", Wiley, 2009
- [9] E. Fishler, A. Haimovich, R. Blum, D. Chizhik, L. Cimini and R. Valenzuela, "MIMO Radar: An Idea Whose Time Has Come", Proceedings of IEEE International Conference on Radar, pp. 71-78, Apr. 2004
- [10] D.W. Bliss and K.W. Forsythe, "Multiple-Input Multiple-Output (MIMO) Radar and Imaging: Degrees of Freedom and Resolution"
- [11] J. Li and P. Stoica, "MIMO Radar – Diversity Means Superiority", Proceedings of the 14th Annual Workshop on Adaptive Sensor Array Processing, MIT Lincoln Laboratory, Lexington, MA, Jun. 2006
- [12] N. H. Lehmann et al., Spatial diversity in radars—models and detection performance, IEEE Trans. Signal Process. 55 (5):2215–2225 (May 2007).

- [13] X. Dai, J. Xu, Y. Peng, and X. Xia, A new method of improving the weak target detection performance based on the MIMO radar, Proc. 2006 CIE Int. Conf. Radar, Oct. 2006.
- [14] J. Li and P. Stoica, "MIMO Radar With Colocated Antennas", IEEE Signal Processing Magazine, vol. 24, no. 5, pp. 106-114, Sep. 2007
- [15] D.R. Fuhrman and G.S. Antonio, "Transmit Beamforming For MIMO Radar Systems Using Partial Signal Correlation", Proc. 38th Asilomar Conf. Signals, Syst. Comput., vol. 1, pp. 295-299, Nov.2004
- [16] D.R. Fuhrman and G.S. Antonio, "Transmit Beamforming For MIMO Radar Systems Using Signal Cross-Correlation", IEEE Transactions on Aerospace Electronic Systems,
- [17] P. Stoica and J. Li, "On Probing Signal Design For MIMO Radar", IEEE Transactions on Signal Processing, vol. 55, no. 8, pp .4151-4161, Aug. 2007
- [18] K. Shadi, F. Behnia, MIMO radar beamforming using orthogonal decomposition of correlation matrix, Circuits, Systems, and Signal Processing, pp 1–19, 2013.
- [19] F.C. Robey, S. Coutts, D. Weikle, J.C. McHarg, K. Cuomo, "MIMO Radar Theory and Experimental Results", Proceedings of the 38th Asilomar Conference on Signals, Systems and Computers, vol. 1, pp. 300-304, Nov.2004
- [20] L. Xu, J. Li, P. Stoica, "Radar Imaging via Adaptive MIMO Techniques", Proceedings of 14th European Signal Processing Conference, Sep. 2006
- [21] E. Fishler, A. Haimovich, R. Blum, L. J. Cimini, D. Chizhik and R. Valenzuela, "Spatial Diversity in Radars – Models and Detection Performance", IEEE Transactions on Signal Processing, vol. 54, no. 3, pp. 823-838, Mar. 2006
- [22] A. M. Haimovich, R. S. Blum and L. J. Cimini, "MIMO Radar with Widely Separated Antennas", IEEE Signal Processing Magazine, vol. 25, no. 1, pp. 116-129, Jan. 2008

- [23] A.Hassanien and S. Vorobyov, "Phased-MIMO Radar: A Tradeoff Between Phased-Array and MIMO Radars", IEEE Transactions on Signal Processing, vol. 58, no. 6, pp. 3137-3151, Jun. 2010
- [24] S. Boyd and L. Vandenberghe, Convex Optimization. Cambridge,UK: Cambridge Univ. Press, 2004.
- [25] A. Hassanien and S. A. Vorobyov, "Transmit/receive beamforming for MIMO radar with collocated antennas", Proc. IEEE Int. Conf. Acoust., Speech Signal Process., pp. 2089 - 2092, 2009.
- [26] CVX Research, Inc. CVX: Matlab software for disciplined convex programming, version 2.0. <http://cvxr.com/cvx>, April 2011.
- [27] M. Grant and S. Boyd. Graph implementations for nonsmooth convex programs, Recent Advances in Learning and Control (a tribute to M. Vidyasagar), V. Blondel, S. Boyd, and H. Kimura, editors, pages 95-110, Lecture Notes in Control and Information Sciences, Springer, 2008. http://stanford.edu/~boyd/graph_dcp.html.
- [28] Y. Yang and R. S. Blum, MIMO radar waveform design based on mutual information and minimum mean-square error estimation, IEEE Trans. Aerospace Electron. Syst.43(1):330–343 (Jan. 2007).