

**BREAKDOWN VOLTAGE MODELING FOR LEATHERITE
PAPER DIELECTRICS USING FUZZY LOGIC TECHNIQUE
&
ESTIMATING THE LIFETIME USING STEP-STRESS TEST**

**A THESIS SUBMITTED IN PARTIAL FULFILLMENT OF THE
REQUIREMENTS FOR THE DEGREE OF**

Bachelor of Technology

in

Electrical Engineering

By

**SANTOSH KUMAR MOHAPATRA
AJAY SINHA
SAROJ BARIHA**



Department of Electrical Engineering

National Institute of Technology

Rourkela

2007

**BREAKDOWN VOLTAGE MODELING FOR LEATHERITE
PAPER DIELECTRICS USING FUZZY LOGIC TECHNIQUE**

&

ESTIMATING THE LIFETIME USING STEP-STRESS TEST

**A THESIS SUBMITTED IN PARTIAL FULFILLMENT OF THE
REQUIREMENTS FOR THE DEGREE OF**

**Bachelor of Technology
in
Electrical Engineering**

By

**SANTOSH KUMAR MOHAPATRA
AJAY SINHA
SAROJ BARIHA**

**Under the Guidance of
Prof. S. Ghosh**



**Department of Electrical Engineering
National Institute of Technology**

Rourkela

2007



National Institute of Technology Rourkela

CERTIFICATE

This is to certify that the thesis entitled, "**Breakdown Voltage Modelling For Leatherite Paper Dielectrics Using Fuzzy Logic Technique & Estimating The Lifetime Using Step-stress Test**" submitted by **Sri Santosh Kumar Mohapatra, Sri Ajay Sinha, Sri Saroj Bariha** in partial fulfillment of the requirements for the award of Bachelor of Technology Degree in Electrical Engineering at the National Institute of Technology, Rourkela (Deemed University) is an authentic work carried out by him under my supervision and guidance.

To the best of my knowledge, the matter embodied in the thesis has not been submitted to any other University/Institute for the award of any Degree or Diploma.

Date :

Place:

Prof. S. Ghosh

Dept. of Electrical Engg.

National Institute of technology

Rourkela-769008

ACKNOWLEDGEMENT

We would like to articulate our deep gratitude to our project guide **Prof. S. Ghosh** who has always been our motivation for carrying out the project.

We wish to extend our sincere thanks to **Prof. P. K. Nanda**, Head of our Department, for allowing us to use the facilities of the “Computing and Simulation Lab”

We wish to extend our sincere thanks to Dr **Santosh Kumar Nanda** for his help.

It is our pleasure to refer Microsoft Word exclusive of which the compilation of this report would have been impossible. Also it would not have been possible to complete the project without the simulation software”MATLAB”

A project of this nature could never have been attempted with our reference to and inspiration from the works of others whose details are mentioned in references section. We acknowledge our indebtedness to all of them. Last but not the least, our sincere thanks to all of our friends who have patiently extended all sorts of help for accomplishing this undertaking.

**SANTOSH KUMAR MOHAPATRA
AJAY SINHA
SAROJ BARIHA**

ABSTRACT

OBJECTIVE

The real insulation systems are often heterogeneous and some times nonlinear. Quality of insulation is accessed in terms of break down strengths. Partial discharge caused in insulation system by local defects and the resultant overstressing caused by them ultimately lead to breakdown. So the estimation has to be done properly to save insulation from failure. The use of modern computers in bdv analysis has lead to the estimation based on fuzzy logic modeling. The mamdani fuzzy logic using triangular and trapezoidal mf used for the modeling.

The bdv got from the modeling section is used to get the weibull parameters using MLE. The shape parameters are used for the life estimation of the dielectric.

DESCRIPTION

Fuzzy logic modeling is widely used in those fields where the boundary between having a property and not having it is not sharp. The construction of this model can be viewed as a process in which a collection of objects called variables and parameters of the model are related by some other objects called the operators of the model. In the present case it is tried to estimate the bdv of dielectrics depending upon various input conditions.

The most important source of partial discharge and breakdown in dielectrics is the voids. Voids are produced due to process control errors at the time of production of most of the solid dielectrics. This is a gas discharged event. The test dielectric is taken as leatherite paper and the estimation is based on data experimentally generated in the laboratory using a CIGRE-2 electrode. The choice of test procedure to know the breakdown voltage of a typical insulation material on insulation system is determined by the test objective. Constant voltage tests provide reliable comprehensive data for the distribution function of the breakdown time but is very time consuming. An accelerated test with increase in voltage stress in discrete steps is quite often used for an electrical insulation study and is widely accepted by the insulation designers. With this method the stress at which the insulation breaks down and time to failure is taken as

observed variable The effect of void dimensions on the output is studied and implemented in MATLAB environment.

The various steps in modeling include study of the range variation, grouping, rule list generation and simulation. Present system is a MISO system having three inputs (thickness of dielectric, depth and diameter of void) and one output (bdv). The min max algorithm is used as t-norm and s-norm operator. Coa is used for defuzzification. Programming approach is adopted for estimation. The surface plot is plotted to study the variation.

Weibull probability has gained wide acceptance in the statistical treatment of time to electrical breakdown of solid dielectrics. It seems to fit experimental data well. MLE is used for parameter estimation. Confidence interval is chosen to get lower and upper limits of the parameters within which the estimation lie for a surety.

Throughout the experiment the step stress test is considered. The inverse power law is applied to life estimation. From the slope of the graph the slope is to be found out and used for estimating the life.

RESULTS

In the mamdani fuzzy logic modeling using the triangular and trapezoidal mf the Mae is found out to be 1.4% and 1.324% respectively.

The weibull parameters and life estimation values have close resemblance with the experimentally generated value.

CONCLUSION

Fuzzy logic provides an easier and a better computation technique based on the fuzzyness of rules. By accurately choosing the parameters and deciding the rule bases the error can be significantly reduced. The weibull parameter calculation using MLE and lifetime also found to be in good agreement. Thus the results indicates that the modeling can be well implemented for such kind of estimation.

CONTENTS

Certificate	i
Acknowledgement	ii
Abstract	iii-iv
Contents	v-vi
1. Introduction	1-6
1.1 Motivation	
1.2 Preliminary Idea About Dielectrics	
1.3 The Truth About Breakdown Voltage	
1.4 The Truth About Voids	
1.5 Introduction To Weibull Function Distribution	
1.6 Introduction To Life Estimation	
1.7 objectives And Organisation Of Thesis	
2. Literature Survey	7-22
2.1 Breakdown Voltage Phenomena	
2.2 Experimental Setup	
2.3 Fuzzy Logic Modeling	
2.3.1 Introduction to Fuzzy Logic	
2.3.2 Triangular MF	
2.3.3 Trapezoidal MF	
2.3.4 Fuzzy Interference System	
2.3.5 Mamdani Fuzzy Model (MFM)	
2.3.5.1 Triangular Norm	
2.3.5.2 Triangular Conorm	
2.3.5.3 Defuzzification	
2.3.6 Working Model of Mamdani Model	
2.3.7 Steps To Be followed For Modeling	
2.3.8 Mechanism of Rule Generation	
3. Estimation of BDV by Fuzzy Logic Technique	23-35
3.1 Introduction	
3.2 Implementation Of Fuzzy Logic Model By Triangular MF	
3.2.1 Range Variation Study	
3.2.2 Considering MF	
3.2.3 Specification of MF	
3.2.4 Rule Base Generation	
3.3 Implementation Of FL Model By Trapezoidal MF	
3.3.1 Range Variation Study	
3.3.2 Considering MF	
3.3.3 Specification of MF	
3.3.4 Rule Base Generation	
3.4 Simulation Using MATLAB	
3.5 Results	
3.6 Comparison	
3.7 Discussion	

3.8 Conclusion	
4. Weibull Function Estimation Using MLE	36-41
4.1 Introduction	
4.2 Weibull Function	
4.3 Techniques For Estimation	
4.3.1 Maximum Likelihood Estimation	
4.4 Confidence Interval	
4.5 Results	
4.6 Conclusion	
5. Life Estimation Using Step Stress Test	42-45
5.1 Introduction	
5.2 Theory of Step Stress	
5.3 Experimental Procedure	
5.4 Results	
5.5 Discussion	
6. Graphs & Surface Plots	46-54
7. Conclusion	55-57
7.1 Introduction	
7.2 Summary	
7.3 Conclusion	
References	58
Annex	

Chapter 1

INTRODUCTION

1.1 Motivation

The real insulation systems are often heterogeneous and some times nonlinear. Important examples of composite insulation systems are an entrapped gas with in a solid insulation. Quality of electrical insulation is usually accessed in terms of breakdown strength of the dielectric, which can be influenced by many physical parameters such as, voltage waveform, frequency, partial discharge, temperature, humidity, impurities, thickness of the insulation and dielectric constant.

Partial discharges caused in insulation systems by local defect such as foreign particle inclusion, voids or surface inhomogenities comprise a large variety of physical phenomena. Electrical overstressing, caused by these defects contribute to the insulation degradation and breakdown, while in service. The deleterious effect of such voids and break down in solid dielectrics has long been recognized and the mechanisms of breakdown are still under investigation.

A considerable volume of data has been accumulated over the last few last decades on the subject of breakdown. Quantitative numerical solutions are developed in solid dielectric mostly based on artificially created defects on voids. Voltage required to produce breakdown of a dielectric depends upon the void dimensions apart from the kind of gas in the cavity and the gas pressure. However the breakdown in independent of the nature of the dielectric and of the void location.

The increased use of modern computer technology in break down data collection and analysis has laid to Breakdown voltage estimation based Fuzzy logic modeling. The MAMDANI fuzzy logic using triangular and trapezoidal membership function (MF) used for the modeling such a system based on learning of input-output mapping from the training samples using the void dimensions as the input parameters. The mean absolute error for estimated and measured value of breakdown voltage (BDV) was found to be 1.4% and 1.324% for triangular mf and trapezoidal mf respectively. We have been motivated to work on different MFS and compare results.

1.2 Preliminary idea about Dielectrics

Electrical insulation is a material which contains no free electron to permit the flow of electricity. When a voltage is placed across a dielectric, no current flows. It is intended to separate electrical conductors without passing current through itself. Electrical insulation is the absence of electrical conduction. Electronic band theory predicts that a charge is flow whenever there are states available into which the electrons in a material can be excited. This allows them to gain energy and there by move through the conductor.

Most dielectrics are characterized by having a large band gap. This occurs because the “Valance” band containing the highest energy electrons in full, and a large energy gap separates this band from the next band above it. There will some voltage always present (called breakdown voltage) that will give the electrons enough energy to be excited in to this band.

1.3 The truth about Breakdown voltage

Breakdown voltage is a characteristic of an insulator that defines the maximum voltage difference that can be applied across the material before the dielectric collapses and conducts. In solid insulating material or liquid impregnated insulating material, this usually creates a weaken path with in the material by creating permanent molecular or physical degradation by the sudden flow of current.

1.4 The truth about Voids

The most important source of partial discharge and corresponding breakdown is in all probabilities voids with in a more dense dielectric system. Voids are produced due to process control errors at the time of production of most of the solid dielectric or liquid impregnated solid dielectrics. Cavities with in the epoxy matrix can be formed at the time of manufacturing due to poor shrinkage during curing, vaporization of volatile components, separation of dielectric or metal surface etc.

Partial discharge is generally a gas discharged event. Like other gas discharge phenomena, initiation of discharge starts when two basic conditions are met. The first condition is met when the electric field stress within the void exceeds the minimum field, E_1 . This stress depends on the cavity parameter, gas occlusion with in the void and the gas pressure, which is not known precisely in many cases. The second

requirement is the availability of free electrons. The time required for availability of free electrons is usually termed statistical time lag, it can be long and may be very from minutes to hours or days depending on cavity size.

In a practical situation when there is a void in the system and the voltage is increased slowly then discharge may not sustain. However with lapse of time the spontaneous and sustained discharge occurs and the stress is many folded across the void and result in complete breakdown of the dielectric. When sustained discharge starts then due to active ionization the abundance in free electron occurs.

1.5 Introduction to Weibull Function distribution:

Weibull probability distribution has gained much acclaim as a statistical treatment method of solid dielectrics. The distribution seems to fit the experimental life data better than others. But the problem sometime remains with the versatility of the method i.e. the parameter tends to be relatively insensitive to the random variable. But Weibull function distribution is Superior to the earlier methods. As the earlier ones are subjective and observer sensitive. Now a lot many advances have been made in the field of Weibull function estimation. The cumulative Weibull distribution function is represented by

$$F(t) = 1 - \exp [-(t/\theta)^\beta]$$

It is used for two parameter system.

where

θ = scale parameter

B = shape parameter

The present problems are based on applying a step stress to a dielectric under stress and study its breakdown voltage and behavior. The life test in which the solid dielectric is subjected to constant high voltage stress until failure, called constant voltage stress test. In step voltage stress test, the voltage is increased at a constant rate or in steps until the insulation gets punctured.

There are different techniques available for estimation of Weibull parameters, e.g. Monte-Carlo simulations, maximum likelihood(MLE), least square using Bernard

and Weibull rank estimator s and the white technique. Out of these MLE is most widely used and is proposed to be used in the present work.

Once the parameter θ & β are calculated the confidence intervals are assigned to get the upper and lower limits of the estimates within which these will lie for most of the cases.

1.6 Introduction to life estimation

Accelerated aging tests are widely accepted in testing of dielectric materials used for electrical operations. Various time intervals for the step stress test are selected. The inverse power law has used in the analysis of the experimental data, with the value of power exponent determined from the step stress test. The Weibull distribution was employed in the analysis of the experimental data.

The inverse power model has been frequently used to estimate life times of insulating materials under voltage stress. In simplest form, this model is represented by the equation

$$t^* v^n = k$$

where

t is the time to breakdown at voltage stress v , n and k are constants. Assuming a cumulative nature of damage to the insulation, the inverse power model may also be applied to step-stress test. In this method the voltage is raised in steps and held constant at each step for same time interval.

1.7 Objectives and organization of thesis

In this project paper we have tried our best to estimate every aspect of dielectric as related to the breakdown. First the leatherite paper is chosen as the test dielectric and its breakdown data are considered from the test data from the thesis paper of S.Ghosh. Then the fuzzy logic model is adopted to get the estimation of the breakdown voltage as output from the input provided. After the successful estimation of BDV we have extended our interest towards the Weibull function distribution and estimating the life of insulation and ageing problem. In every case the same test data as provided by S.Ghosh is used with step stress voltage input.

In the present thesis, we have introduced six chapters. We have devoted the 1st chapter towards introduction, 2nd chapter towards basics of fuzzy logic

basics and chapter 3 to 5 towards the real work of project that is estimation of breakdown voltage of dielectric, Weibull function distribution estimation and life estimation respectively. The chapter 6 contains the conclusion to the whole thesis.

Chapter 1, which includes the generalized introduction contains the motivation towards taking the project and basic knowledge of the various process used in present work for the sack of concept clarity.

Chapter 2 contains the basics of fuzzy logic model and its working mechanism. The membership function assignment, different operator choosing, fuzzifying the inputs, rule base generation and defuzzification steps are elaborately explained there.

In chapter 3 the estimation of BDV by using fuzzy logic model is presented. The training data are taken, how the MFS are considered, zones are taken and fuzzyfied, rule base is generated and finally defuzzyfication step is done to get crisp output is elaborately explained there. The results are also compared with the experimental results and the Mean Absolute Error (MAE) is calculated.

Chapter 4 is devoted towards the Weibull function distribution estimation. The scale parameter (θ) and shape parameter (β) are calculated by maximum likely hood estimation (MLE). After that the confidence interval is chosen and the upper and the lower limits of the parameters are found out which provides some kind of surety of estimation.

Chapter 5 takes the results found in the previous sections and uses them to estimate the life of the dielectric. The inverse power model is frequently used in this estimation. The variation of BDV according to steps and other inputs are studied graphically.

Chapter 6 is the generalized conclusion. It sums up the conclusion of each chapter and gives the various highlighted points, lacuna of the system and various aspects in which the present estimation is to be modified in future.

Chapter 2

LITERATURE SURVEY

2.1 Breakdown voltage phenomena

AC breakdown mechanism in solid dielectrics is not well understood due to its complexity since it is accompanied by dielectric loss heating in addition to charge multiplication and joule heating. The mechanism complexity further increases in the presence of entrapped foreign particles/gas within the dielectric material. Voids created during manufacturing process are one of the main sources of problem for solid insulating material. Due to the application of voltage, in service, the electrical stress experienced by the void initiate PD when stress value exceeds a certain critical value. Those eventually cause material degradation and lead to the final breakdown. Extensive studies have already been done to investigate various aspects of solid insulating materials to understand their general properties, electrical characteristics and aging effect. Various studies have been carried out to evaluate the breakdown voltage and its dependence on various electrode configurations.

Let's take the case of leatherite paper for the study of voids and breakdown. Voids are generally introduced during the extrusion process. They may also occur due to the maintenance of poor vacuum during the during the impregnation cycle as is the often the case with epoxy cast instrument transformer.

Whether or not the presence of certain voids in a given insulation system can eventually lead to breakdown will depend primarily on whether or not the occluded void under go partial discharge under the operating voltage stress and on the intensity of the partial discharge process itself as well as on the degradation characteristics of the insulating materials involved. Obviously voids which do not discharge under the normal operating voltage conditions, are quite innocuous. Infact, discharge –free void represent the near ideal case of a loss free dielectric.

Voids occluded in the insulation systems of electrical apparatus are always subjected to higher electrical stresses than the adjacent solid or liquid insulating media. If we consider a simple flat-shaped cavity or void in series with a liquid insulation subjected to an average electrical stress ξ and having a dielectric constant of value ϵ , then the stress across our ideal cavity is equal to $\epsilon \xi$.

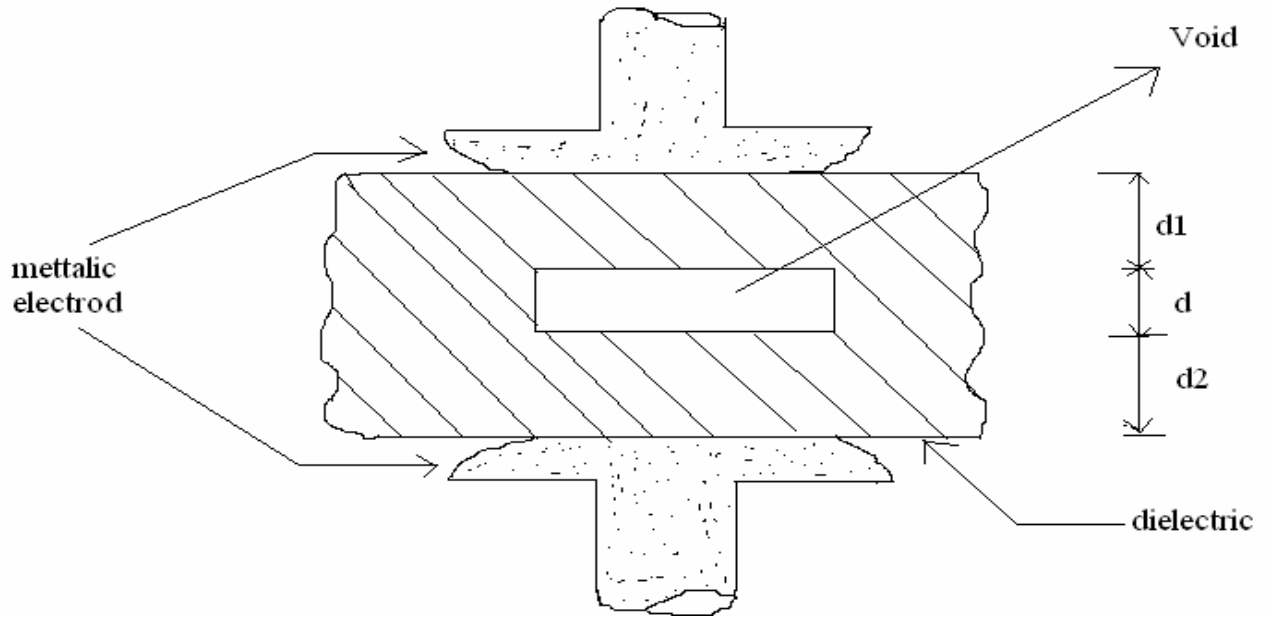

Fig 2.1- Parallel plate voids inclusion within a dielectric material between the two test electrodes.

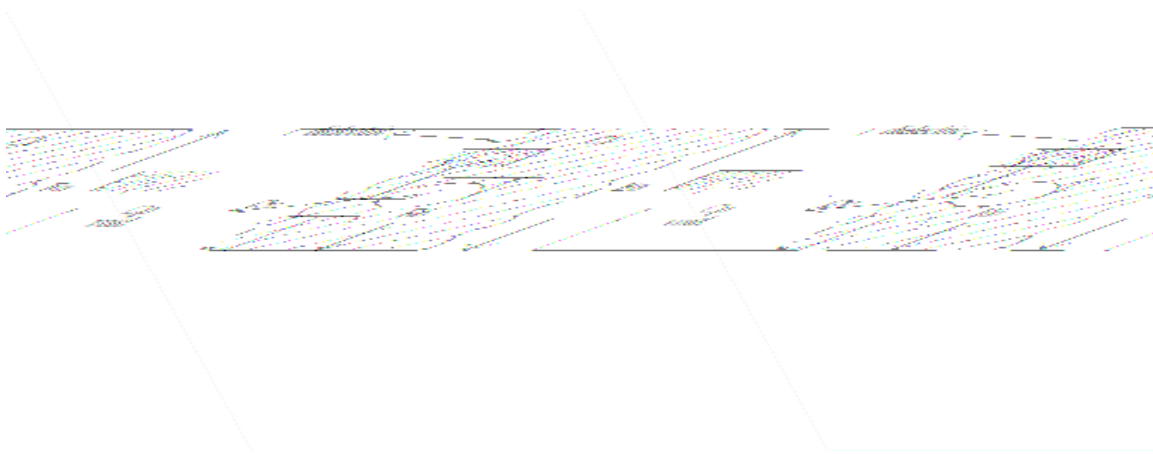

Fig 2.2- Dielectric with void inclusion and its corresponding electrical equivalent circuit.

Figure 2.1 shows the parallel plate void inclusion with in a dielectric material the two test electrodes. Fig. 2.2 shows the dielectric with void inclusion and its corresponding equivalent circuit.

2.2 Experimental Set-up

The choice of test procedure to know the breakdown voltage of a typical insulation material on insulation system is determined by the test objective. Constant voltage tests provide reliable comprehensive data for the distribution function of the breakdown time but is very time consuming. An accelerated test with increase in voltage stress in discrete steps is quite often used for an electrical insulation study and is widely accepted by the insulation designers. With this method the stress at which the insulation breaks down and time to failure is taken as observed variable

A. Dielectric considered:

The Leatherite paper is considered for testing

B. Electrode geometry:

Fig. 2.3 shows the CIGRE-II electrode geometry used for the breakdown voltage measurements. The electrode used is made of brass. They were polished, buffed and clean with ethanol. Sufficient care is taken to keep the electrode surface untouched and free from scratches, dust and other impurities. The insulation sample is sandwiched between electrodes as shown.

C. Sample preparation:

The samples are prepared from commercially available insulation sheets of 45 mm diameter. Three different thickness of the insulation, i.e. 0.18, 0.23 and 0.3 mm are used here. The surface of the insulating should be cleaned and keep dry, since moisture or contamination or insulating specimen may affect breakdown voltage. Before testing the conditioning procedure adopted to condition the test specimen is in accordance with that laid in ASTM hand book. This avoids surface discharges at much lower level of voltage.

D. Creation of Void:

The artificial void is created by means a spacer made up of Kapton film with a punched hole at the centre. The spacer used is of different thickness varying from 0.0625 mm to 0.25 mm through 0.125 mm to create different size of voids. The diameter of the central hole varies from 1 to 5mm.

E. Measurement of Breakdown voltage:

The applied voltage at 50 Hz AC is obtained from a 60 KV discharge free testing transformer (Siemen, AG). The voltage is raised in step of 500 volt and held constant until breakdown occurs. The total time of applied stress and the voltage which breakdown occurs are noted. Five data points are obtained for each time interval for each sample. The five intervals of 15S, 30S and 60S are used for the step stress test. All tests are carried out at room temperature.

The physical examination of the samples after breakdown test showed, in general, that the break down occurs at the centre of the insulation samples. Further it is seen that the breakdown voltages are lying within a close range. A mean value of the five such breakdown voltages are taken for studies.

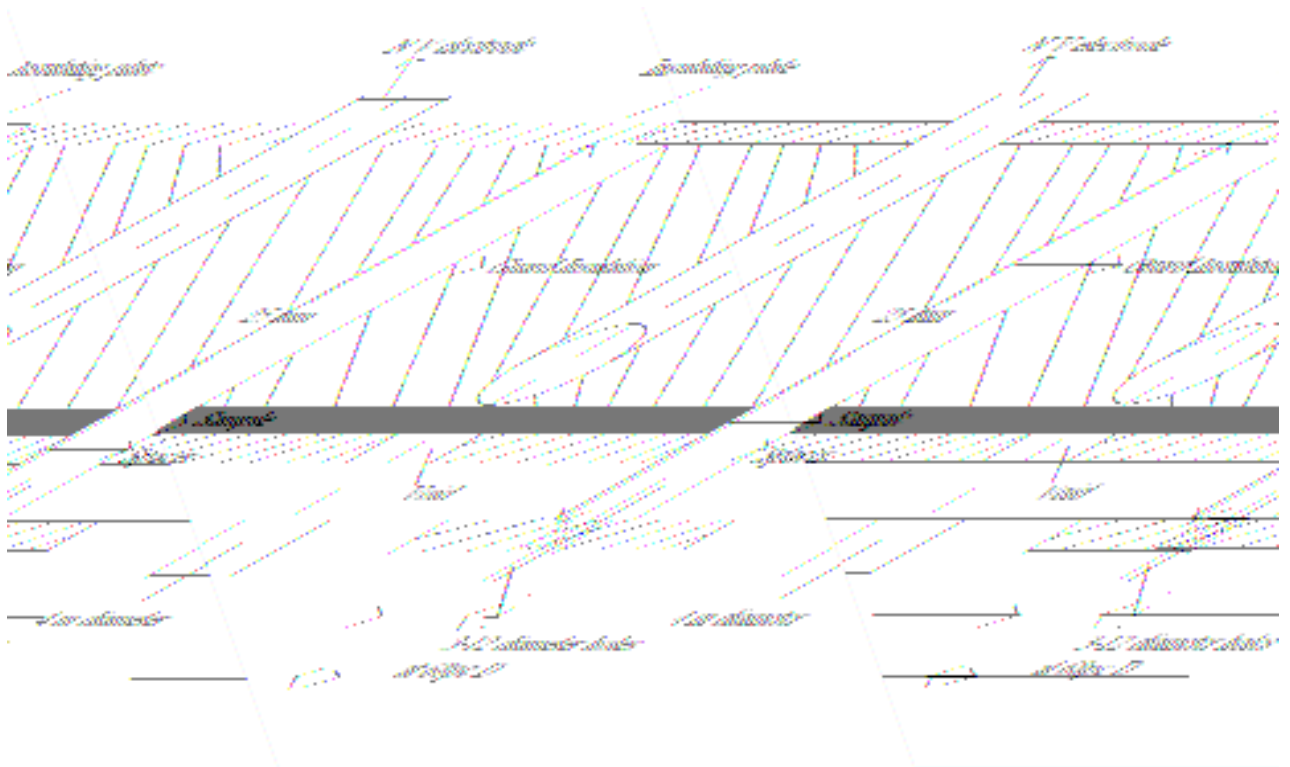

Fig 2.3- CIGRE method 2 electrode system.

2.3 FUZZY LOGIC MODELING

2.3.1 Introduction to Fuzzy Logic

Fuzzy sets were introduced in 1965 by Lofti Zadeh as a new way to represent vagueness in everyday life. A classical set is a set with crisp boundary. Fuzziness does not come from the randomness of the constituent members of the sets but from the uncertain and imprecise nature of abstract thoughts and concepts. Imprecision in data and information gathered from and about our environment is either statistical or non statistical. Latter type of uncertainty is called fuzziness. Statistical models deal with the random events and non random precisions, whereas fuzzy model attempts to capture and quantify non random imprecision [3].

Characteristic function of a fuzzy set is allowed to have values between 0 & 1, which denotes the degree of membership of an element in a given set.

Let X is a collection of objects denoted generically by x, then a fuzzy set A in X is defined as a set of ordered pairs,

$$A = \{(x, \mu_A(x)) / x \in X\} \dots\dots\dots (2.1)$$

Where $\mu_A(x)$ is called the membership function (MF) for the fuzzy set A. The MF maps each element of X to a membership grade between 0 & 1. A more convenient and concise way to define an MF is to express it as a mathematical formula [2].

For simplicity, we may use parameterized MFs of one dimension-that is MFs with single input.

2.3.2 Triangular MF

A triangular MF is specified by three parameter {a,b,c} as follows.

$$T = [\text{Base 1} \quad \text{Height} \quad \text{Base2}] \dots\dots\dots (2.2)$$

$$\text{triangle}(x; a, b, c) = \begin{cases} 0 & , x \leq a \\ (x-a)/(b-a) & , a \leq x \leq b \\ (c-x)/(c-b) & , b \leq x \leq c \dots\dots\dots (2.3) \\ 0 & , c \leq x \end{cases}$$

By using the minimum and maximum an alternative expression may be written as
 triangle $(x;a, b,c) = \max (\min((x-a)/(b-a),(c-x)/(c-b)),0).....(2.4)$

The parameters $\{a,b,c\}$ with $(a<b<c)$ determine the x-coordinates of the three corners of the triangular MF. The algorithm for triangular MF is given in the Annexure part.

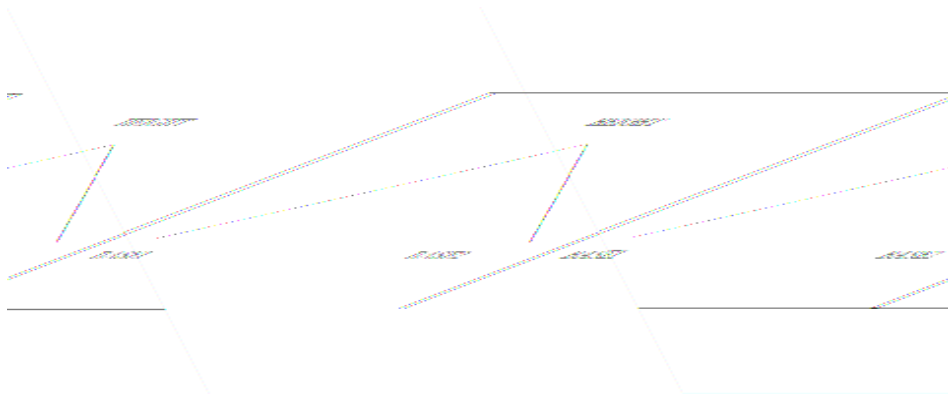

Fig 2.4- Triangular membership function

2.3.3 Trapezoidal MF

A trapezoidal MF is specified by four parameters $\{a, b, c, d\}$ as follows

$$T = [\text{base1} \quad \text{height1} \quad \text{height2} \quad \text{base2}]..... (2.5)$$

$$\text{trapezoidal} (x;a,b,c,d) = \begin{cases} 0 & , x \leq a \\ (x-a)/(b-a) & , a \leq x \leq b \\ 1 & , b \leq x \leq c \\ (d-x)/(d-c) & , c \leq x \leq d \\ 0 & , d \leq x \end{cases}(2.6)$$

By using minimum and maximum, an alternative expression may be written as,

$$\text{trapezoidal} (x;a,b,c) = \max (\min((x-a)/(b-a),1,(d-x)/(d-c)),0).....(2.7)$$

The parameters $\{a, b, c, d\}$ with $(a<b<c<d)$ determines the x-coordinates of the four corners of the underlying trapezoidal MF.

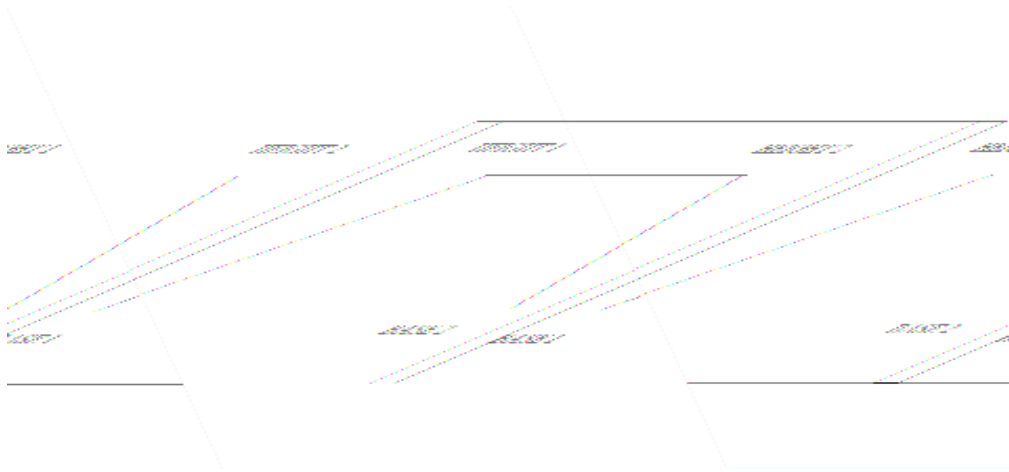

Fig2.5- Trapezoidal membership function

Due to simple formulae and computational efficiency, both triangular MFs and trapezoidal MFs are extensively used, especially in real-time implementations. In this project work triangular MF & trapezoidal MF are used and their performance is compared.

There are two kinds of model in fuzzy logic modeling. They are

- (i) Mathematical model (using algebraic operation)
- (ii) Logical model (using logical type connectives)

2.3.4 Fuzzy inference system

Currently, major application of fuzzy logic has been in a class of logic type models called ruled-based or knowledge-based models. Due to the logical nature of the model, the process of obtaining the output for a given input to the system is called fuzzy inference system (FIS).

FIS is a popular computing framework based on the concept of fuzzy set theory, fuzzy if-then rules and fuzzy reasoning. Generally it is multidisciplinary in nature.

The basic structure of a FIS consist of three conceptual components-

- (i) A rule base, which contains selection of fuzzy rules.
- (ii) a data base ,which defines the membership function used in fuzzy rules
- (iii) a reasoning mechanism, which performs the interference procedure upon the rules and given facts to derive a reasonable o/p

In basic FIS the inputs may either be fuzzy set or crisp but the o/p is always fuzzy set. In some applications where the system used as controller, one often need crisp output. So, defuzzification is performed to extract crisp value that best represents the fuzzy set.

With crisp i/p and o/p the system performs a non linear mapping from input apace to out put space. The rules are basically IF-THEN rules. The sentence following the IF part is called “antecedent” and that following the THEN part is called “consequent”.

There are three types of FIS such as,

- (i) Mamdani Fuzzy model (MFM)
- (ii) Sugeno Fuzzy model (SFM)
- (iii) Tsukamoto Fuzzy model (TFM)

The difference between these lie in consequent, aggregator and defuzzifier. Due to simplicity Mamdani fuzzy model is used in this work.

2.3.5 Mamdani Fuzzy model (MFM):

In mamdani fuzzy model, we try to model a controller based on a set of linguistic control rules obtained from operators. Linguistic model describes the system by means of a set of IF-THEN rules with vague predicates. The model is a knowledge based system which contains rules and incorporates fuzzy inherently. The fuzzy reasoning depends upon the choice of T-norm and T-conorm operators.

2.3.5.1 Triangular-Norm (T-Norm) :

It is the class of fuzzy intersection operators.

These are of four types

- (i) Minimum $T_{\min}(a,b) = \min(a,b) = a \cap b$
- (ii) Algebraic product $T_{ap}(a,b) = ab$
- (iii) Bounded product $T_{bp}(a,b) = 0 \vee (a+b-1)$
- (iv) Drastic product $T_{dp}(a,b) = \begin{cases} a, & \text{if } b = 1 \\ b, & \text{if } a = 1 \\ 0, & \text{if } a, b < 1 \end{cases}$

2.3.5.2 Triangular-conorm (T-conorm or S-norm)

It is the class of fuzzy union operators. These are of four types.

- (i) Maximum $S(a,b) = \max(a,b) = a \vee b$
- (ii) Algebraic sum $S(a,b) = a+b-ab$
- (iii) Bounded sum $S(a,b) = 1 \wedge (a+b)$
- (iv) Drastic sum $S(a,b) = \begin{cases} a, & \text{if } b = 0 \\ b, & \text{if } a = 0 \\ 1, & \text{if } a, b > 0 \end{cases}$

In the project work, min-max composition used for realization of the fuzzy output. Min-max algorithm means in T-norm operator is min (T_{\min}) and T-conorm operator is max. The crisp output is taken obtain by defuzification.

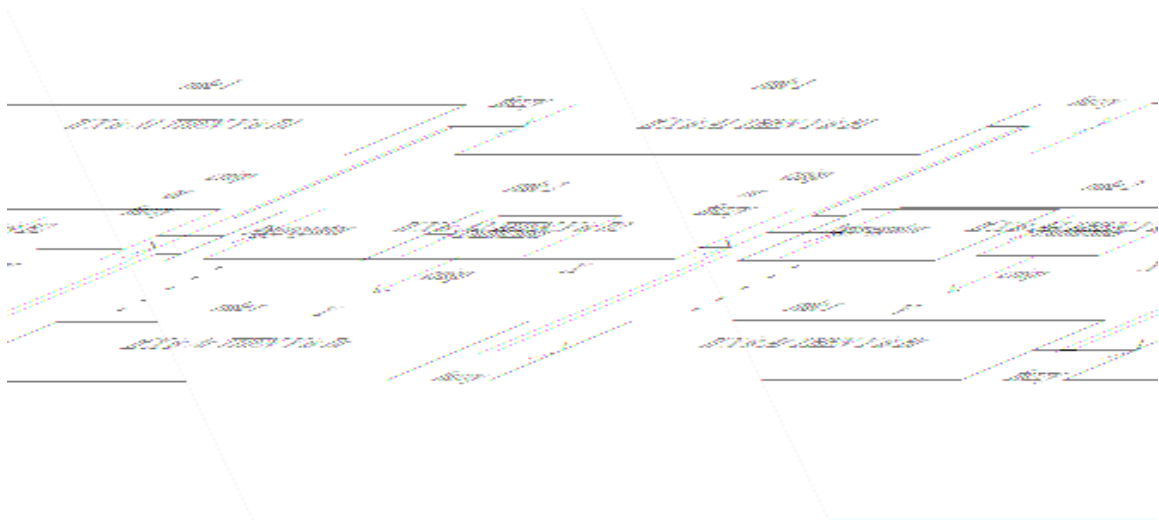

Fig 2.6- Block diagram for fuzzy inference system

2.3.5.3 Defuzzification

It refers to the way a crisp value is extracted from a fuzzy set as a representative value. There are five methods for defuzzification of a fuzzy set A of a universe of discourse Z namely

- (i) Centroid of area (COA)
- (ii) Bisector of area (BOA)
- (iii) Mean of maximum (MOM)
- (iv) Smallest of maximum (SOM)
- (v) Largest of maximum (LOM)

COA defuzzification scheme described as

$$Z_{COA} = \frac{\int z \mu_A(z) dz}{\int \mu_A(z) dz}$$

Where $\mu_A(z)$ = Aggregated O/P mf

BOA difuzification scheme is described as

$$\int_{\alpha}^{\beta} \mu_A(Z) dZ = \int_{\text{BOA}} \mu_A(Z) Dz$$

where $\alpha = \min \{z/z \in Z\}$
 $\beta = \max \{z/z \in Z\}$

MOM difuzification define as scheme described as

$$Z_{\text{MOM}} = \frac{z^1 \int Z dZ}{z^1 \int dZ}$$

Where $z^1 = \{Z/ \mu_A(Z) = \mu^*\}$

Z_{SOM} is the minimum (in terms of magnitude) of the maximizing z.

Z_{LOM} is the maximum (in terms of magnitude) of the maximizing z.

COA difuzification scheme is used in the work. It is the most widely adopted strategy.

In single input single out put (SISO) system there is one antecedent and one consequent

IF K is S₁ THEN L is T₁

ALSO

•

ALSO

IF K is S_M THEN L is T_M

The above described rule base is a SISO Linguistic model. The number of i/p & o/p is problem dependent and may be chosen conveniently. Here K & L are variables of i/p and the o/p respectively.

The present work is a MISO (multi input single output) system ,where there are 3 inputs (thickness of dielectrics , depth of void, diameter of void) and one output (breakdown voltage). For this the IF-THEN rules are written as –

If K1 is S₁₁ and K2 is S₂₂ ANDAND U_r is S_{1r} THEN L is T₁

ALSO

.

ALSO

IF K_m is S_{m1} AND K₂ is S_{m2} ANDAND U_r is S_{mr} THEN L is T_m

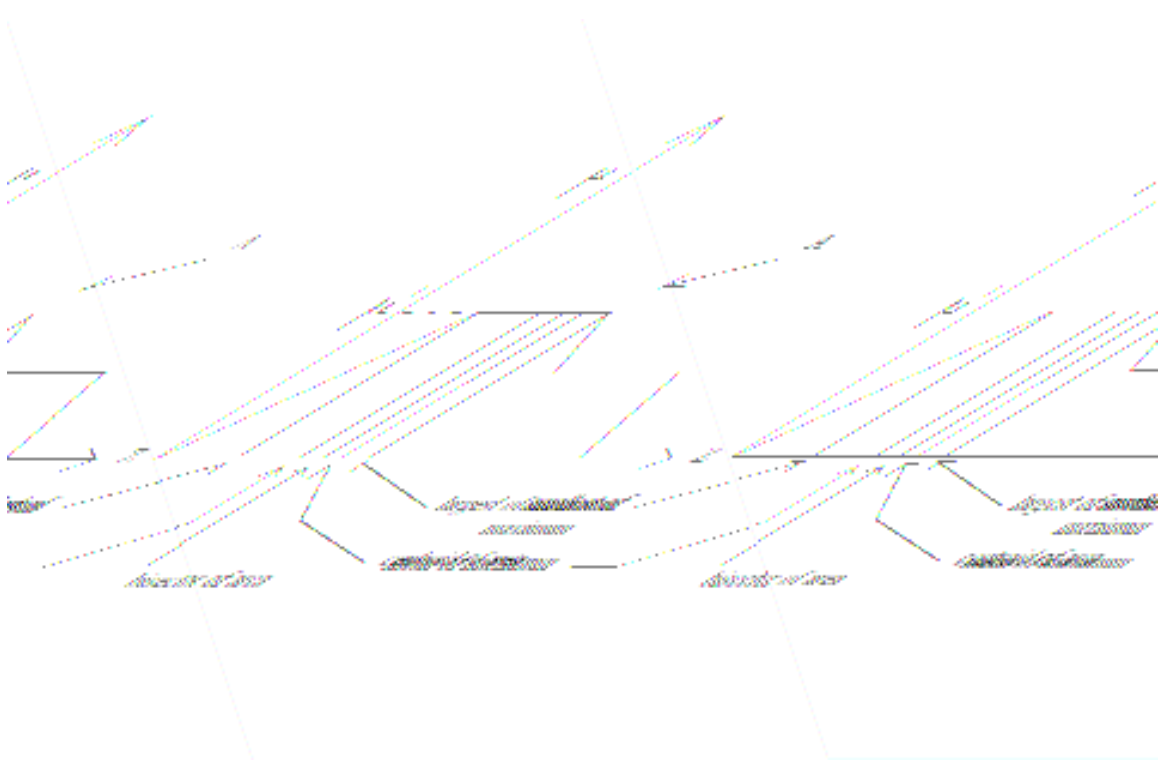

Fig 2.7- Different defuzzification schemes for obtaining crisp output.

2.3.6 Working model of Mamdani model:

The Mamdani model works as follows-

- (1) The rule base is expressed as a fuzzy relation R_i , which is intersection of S_i & T_i

$$R_i = S_i \cap T_i$$

R_i is considered to have T-norm operator min

$$\Rightarrow R_i(x,y) = B_i(x) \wedge D_i(y)$$

Where $x \times y$ is the Cartesian product space.

- (2) In aggregator all the fuzzy relations are joined by union

$$R_{o/p} = \bigcup_{i=1}^m R_i$$

$R_{o/p}$ is considered to have T-conorm operator max.

- (3) In defuzzification COA is adopted to get crisp o/p, which follows as

$$ZCOA = \frac{\int_Z \mu_A(z) z dz}{\int_Z \mu_A(z) dz}$$

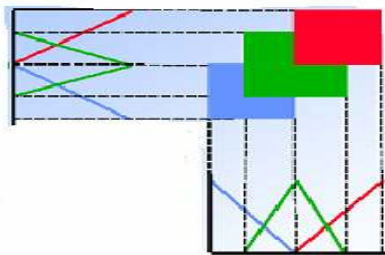

Fig2.8 – Fuzzy rules firing schemes.

2.3.7 Steps to be followed in constructing Linguistic fuzzy model:

The standard method for constructing a FIS is generally called Fuzzy modeling, has the feature as

- (i) Incorporating human expertise about target directly in to modeling process. It takes advantage of domain knowledge.
- (ii) Use of numerical data plays an important role in modeling.

Fuzzy modeling is pursued in two stages. Those are

- (1) Identification of the surface structure
- (2) Identification of the deep structure

In step 1 ,different steps include

- (i) Selection of relevant i/p state and o/p variable
- (ii) Choice of specific type of FIS
- (iii) Finding the number of linguistic terms associated with each i/p and o/p variables
- (iv) Designing of a collection of fuzzy IF-THEN rules

In 1st step one get the rule base of target in linguistic terms. The 2nd stage is more crucial as it determines their meaning.

The step involved in 2nd stage are-

- (i) Choice of appropriate parameterized MFs.
- (ii) Parameters of the MF are to be gathered from human expertise.
- (iii) Evaluating model accuracy and refining the parameters using optimization techniques.

2.3.8 Mechanism of rule base generation

The rule list is prepared by analyzing the training data set obtained from experimental results. It depends upon the learning scheme given for the model. The rule base can be considered as a black box model, the user does not know what is inside that, but when a set of unknown i/ps are fired, according to the learning scheme the o/p is obtained. The accuracy depends upon the learning table.

In rule base generation the 1st step is to drive the i/p and o/p in to number of zones. The ranges of zones are chosen so that they will overlap with each other. So for a particular crisp i/p there are two or more fuzzy o/ps . By intersection mechanism decided by the T-

norm operator one can get the fuzzy output of them. Similarly for all crisp inputs different outputs are obtained. Finally by union mechanism decided by the S-norm operator the final fuzzy output is determined. While choosing the ranges and zones the spreading of data is to be considered. The aggregation of i/p-o/p correspondence is called rule base.

If three i/ps and one o/p is in the present system and three zones are considered in each individual input, the number of rules will be $3 \times 3 \times 3 = 27$. But if two outputs are present for the same system the rule base may be either 27 or 54, depending upon the type of fuzzifier one design.

Chapter 3

ESTIMATION OF BREAKDOWN VOLTAGE BY FUZZY LOGIC TECHNIQUE

3.1 Introduction

The breakdown voltage can be successfully estimated from the three inputs namely thickness of dielectric, depth of void and diameter of void by using the fuzzy logic (FL) method. In the present problem we are using Mamdani FL method. The triangular and trapezoidal MF is considered. Min-max algorithm is taken as T-norm and S-norm operator. COA is used for defuzzification. The rule base is written using IF.....THEN rules

3.2 Implementation of fuzzy logic model by using triangular MF in Mamdani fuzzy model-

The various step associated with the above process are described as below.

3.2.1 The range variation study of input and output parameters

As mention earlier the present project consist of three inputs, namely thickness of the dielectric slab, depth of the void and diameter of void. The only output is breakdown voltage. The training and test data are considered from the set of experimental data are as given in table 3.1 and 3.2.

The experimental data used are during the training and validation process has been obtained from the test performed on leatherite paper by a CIGRE-II electrode system.

The sample dielectric those were tested and used here as i/p parameters during the training process are found to vary as follows.

Thickness of dielectric sheet (x1): 0.18mm to 0.30 mm

Depth of void (x2): 0.0625 mm to 0.25 mm

Diameter of void (x3): 1mm to 5 mm.

Similarly the variation of the output parameter is as follows-

Breakdown voltage (y): 3.3 kv to 4.1 kv

Table 3.1- Training data for estimation of bdv.

Thickness of dielectric(mm)	Depth of void (mm)	Diameter of void(mm)	Breakdown voltage(kv)
0.3	0.0625	1	4.1
0.3	0.0625	5	3.8
0.3	0.125	1	4
0.3	0.125	2	3.9
0.3	0.125	5	3.6
0.3	0.25	2	3.8
0.3	0.25	5	3.6
0.23	0.0625	1	4.1
0.23	0.0625	2	4
0.23	0.0625	5	3.8
0.23	0.125	1	4
0.23	0.125	2	3.9
0.23	0.25	1	3.9
0.23	0.25	5	3.6
0.18	0.0625	1	4
0.18	0.0625	2	3.7
0.18	0.125	2	3.6
0.18	0.125	5	3.4
0.18	0.25	1	3.8
0.18	0.25	2	3.4
0.18	0.25	5	3.3

Table 3.2- Test data for estimation of bdv.

Thickness of dielectric(mm)	Depth of void(mm)	Diameter of void(mm)	BDV(kv) [TARGET]
0.3	0.0625	2	4
0.3	0.25	1	3.9
0.23	0.125	5	3.6
0.23	0.25	2	3.8
0.18	0.0625	5	3.7
0.18	0.125	1	3.9

3.2.2 Considering the MF and assigning ranges to them

In this model, triangular membership function has been chosen for implementation. Each input has three ranges where as the output has five range. The number of ranges depends on our requirement. There are no hand and fast rules on the number of ranges to be considered.

Input (all data in mm)

Input 1 (x1): thickness of dielectric sheet

Low-	0.13	to	0.23	mf1
Medium-	0.20	to	0.30	mf2
High-	0.28	to	0.35	mf3

Input 2 (x2): depth of void

L-	0	to	0.125	mf4
M-	0.08	to	0.212	mf5
H-	0.173	to	0.298	mf6

Input 3 (x3): diameter of void

Less-	0	to	3	mf7
Medium-	1.5	to	4.5	mf8
High-	3	to	6	mf9

Output (all data in kv)

Output 1 (y):

Le-	3.25	to	3.5	mf10
Lm-	3.35	to	3.65	mf11
Me-	3.55	to	3.8	mf12
Hm-	3.7	to	3.95	mf13
Hi-	3.85	to	4.3	mf14

3.2.3 Specification of membership function

As mentioned before triangular membership function is chosen. Each triangular MF is specified by three parameters.

These are

$$T \dots [\text{base1} \quad \text{height} \quad \text{base2}]$$

This MF is assigned to all input and output.

These are from mf1 to mf14. The specification for each MF is given as

Input 1 (x1):

mf1:	[0.13	0.18	0.23]	low
mf2:	[0.20	0.25	0.30]	medium
mf3:	[0.28	0.31	0.35]	high

Input 2 (x2):

mf4:	[0	0.063	0.125]	L
mf5:	[0.080	0.149	0.212]	M
mf6:	[0.173	0.236	0.298]	H

Input 3 (x3):

mf7:	[0	1.5	3]	less
mf8:	[1.5	3	4.5]	medium
mf9:	[3	4.5	6]	high

Output 1 (y):

mf10:	[3.25	3.37	3.5]	Le
mf11:	[3.35	3.52	3.65]	Lm
mf12:	[3.55	3.67	3.8]	Me
mf13:	[3.7	3.82	3.95]	Hm
mf14:	[3.85	3.97	4.3]	Hi

where Le =less

Lm= lower medium

Me= medium

Hm = higher medium

Hi = high

3.2.4 Rule base generation:

The rule list is prepared by analyzing the training data set. Rule base has $(3 \times 3 \times 3) = 27$ rules corresponding to training data. Suppose we are considering the 1st training data set, the input datas are given as 0.3, 0.0625, & 1 and the output is 4.1. Looking the data in their corresponding MFs we get that the inputs lie in the interval H, L, L respectively for the output H. So the rule base is created as :

If x1 is high ALSO IF x2 is low ALSO IF x3 is low THEN y is high.

Similarly 27 rule sets are prepared and the set is called rule base. The rule base is given in the table 3.3.

Table 3.3 – Rule base for triangular mf($3 \times 3 \times 3 = 27$)

Thickness	Depth	Diameter	Breakdown voltage
L	L	L	H
L	L	M	M
L	L	H	M
L	M	L	HM
L	M	M	M
L	M	H	LM
L	H	L	HM
L	H	M	LM
L	H	H	L
M	L	L	H
M	L	M	H
M	L	H	HM
M	M	L	H
M	M	M	HM
M	M	H	M
M	H	L	HM
M	H	M	HM
M	H	H	M
H	L	L	H
H	L	M	H
H	L	H	HM
H	M	L	H
H	M	M	HM
H	M	H	M
H	H	L	HM
H	H	M	M
H	H	H	M

3.3 Implementation of Mamdani fuzzy logic model using trapezoidal

MF:

The input-output relationship is modeled using MFM. The min-max algorithm is used as T-norm & S-norm operator. The membership function considered is trapezoidal one. The COA defuzzification operator is used.

3.3.1 The range variation study of input & output:

The input-output ranges are studied for the given data set as described in 3.3.1. Let us take an example that the data set are given as

	0.3	0.0625	1	4.1
&	0.3	0.0625	5	3.8

So here we can predict that for the third input from 1 to 5 the output lie between 4.1 to 3.8.

3.3.2 Assigning range to the MFs:

In this model the trapezoidal MF has been chosen for implementation. Each input has three ranges where as the output has five range. There is no hard and fast rule regarding deciding the no of ranges. We can consider it depending upon the convenience and requirement.

INPUTS (all data in mm)

Input-1 (x1): thickness of the dielectric sheet

Low-	0.13	to	0.23	mf1
Medium-	0.20	to	0.30	mf2
High-	0.28	to	0.35	mf3

Input-2 (x2): depth of void

L-	0	to	0.125	mf4
M-	0.087	to	0.212	mf5
H-	0.173	to	0.2984	mf6

Input-3 (x3): diameter of void

Less-	0	to	3	mf7
Medium-	1.8	to	4.5	mf8
High-	3.4	to	6	mf9

OUTPUT (all data in kv)

Output-1 (y): breakdown voltage

Le-	3.25	to	3.5	mf10
Lm-	3.35	to	3.65	mf11
Me-	3.52	to	3.8	mf12
Hm-	3.7	to	4	mf13
Hi-	3.86	to	4.3	mf14

3.3.3 Specification of membership function:

As mentioned earlier trapezoidal membership function is chosen. Each trapezoidal membership function is specified by four parameters. These are-

$$T- [\text{base1} \quad \text{height1} \quad \text{height2} \quad \text{base2}]$$

The membership functions are assigned to all input and output. These are from mf1 to mf14. The specification for each mf is given as-

Input-1 (x1):

mf1:	[0.13	0.16	0.20	0.23]	low
mf2:	[0.0	0.23	0.27	0.30]	medium
mf3:	[0.28	0.3	0.33	0.35]	high

Input-2 (x2):

mf4:	[0	0.04	0.08	0.125]	L
mf5:	[0.087	0.13	0.17	0.212]	M
mf6:	[0.173	0.22	0.26	0.2984]	H

Input-3 (x3):

mf7:	[0	0.8	1.8	3]	less
mf8:	[1.8	2.4	3.4	4.5]	medium
mf9:	[3.4	4	5	6]	high

Output-1 (y):

mf10:	[3.25	3.3	3.44	3.5]	Le
mf11:	[3.35	3.47	3.57	3.65]	Lm
mf12:	[3.52	3.62	3.72	3.80]	Me
mf13:	[3.7	3.77	3.9	4]	Hm
mf14:	[3.86	3.93	4.04	4.3]	Hi

3.3.4 Rule base generation

The rule list is prepared by analyzing the training data set. Rule base has 27 rules corresponding to the training data and the ranges chosen for the MFs. The rule base is given in the table 3.4.

Table3.4 – Rule base for trapezoidal mf ($3*3*3=27$)

Thickness of dielectric (mm)	Depth of Void (mm)	Diameter of Void (mm)	Breakdown voltage (kv)
H	L	L	H
H	L	M	H
H	L	H	HM
H	M	L	H
H	M	M	H
H	M	H	LM
H	H	L	HM
H	H	M	ME
H	H	H	LM
M	L	L	H
M	L	M	H
M	L	H	H
M	M	L	HM
M	M	M	H
M	M	L	ME
M	H	L	HM
M	H	M	HM
M	H	H	ME
L	L	L	H
L	L	M	ME
L	L	H	ME
L	M	L	HM
L	M	M	LM
L	M	H	LM
L	H	L	HM
L	H	M	LM
L	H	H	LE

3.4 Simulation using MATLAB

The implementation of fuzzy logic model is done in MATLAB environment. There are two approaches to implement it

- (i) By using fuzzy logic tool box (inherently in MATLAB)
- (ii) By programming the rules (true learning model)

The fuzzy logic tool box is a GUI model which provides all the inbuilt models and rules. By choosing the suitable condition, model, specifying the inputs by edit option, membership function, rules by add rules option. We can create the rule base and realize the simulation. It is very helpful for the beginners and not much depth in programming is required for this. But the modeling may not be efficient and reliable. The approach is crude and fine tuning is not possible.

In contrast the programming approach is very much effective one. However it needs the IF-THEN rules to be written in MATLAB code, which requires indepth knowledge of programming in MATLAB. Further the fine tuning is also can be incorporated.

The accuracy of the simulation depends upon proper range selection and efficient programming. In this project work a software program has been developed for work implementation, keeping in view the reliability and smoothness. The surface plot is also viewed. It gives the idea of variation of output with respect to any two inputs. By proper investigation of the surface plots, it can be used in changing rule base and fine tuning the output.

3.5 Results

3.5.1 Results for MFM using Triangular MF

The fuzzy model was trained and it was tested for correctness and accuracy of model. Suitable care has been taken so that all rules are fired correctly.

Table 3.5 – results of mfm using triangular mf

Thickness of dielectric(mm)	Depth of void(mm)	Diameter of void(mm)	BDV(kv) [TARGET]	BDV(kv) [found]	% error
0.3	0.0625	2	4	4.0458	1.14
0.3	0.25	1	3.9	3.8236	1.956
0.23	0.125	5	3.6	3.6737	2.04
0.23	0.25	2	3.8	3.8237	0.623
0.18	0.0625	5	3.7	3.6737	0.713
0.18	0.125	1	3.9	3.8237	1.956

The MAE of the test data using triangular MF is found to 1.4%.

3.5.2 Results for MFM using Trapezoidal MF

Thickness Of Dielectric (in mm)	Depth Of Void (in mm)	Diameter Of Void (in mm)	Target (in mm)	Found Data (in mm)	% Error	MAE
0.3	0.0625	2	4	4.0465	1.66	
0.3	0.25	1	3.9	3.8435	1.45	
0.23	0.125	5	3.6	3.6638	1.77	1.324%
0.23	0.25	2	3.8	3.8444	1.168	
0.18	0.0625	5	3.7	3.6642	0.967	
0.18	0.125	1	3.9	3.8441	1.43	

The MAE of the test data is found to be 1.324%.

3.6 Comparison between two MFM model using different MFs

In this work, two MFM models are programmed and tested for the input-output relationship using two different MFs i.e. triangular and trapezoidal MFs. By using triangular MF we got the MAE as **1.4%** where as by using trapezoidal MF we got the MAE as **1.324%**.

In present case, we are getting less MAE by the trapezoidal MF but we can't conclude which MF is better. The optimization of result solely depends upon the choosing of ranges and programming efficiently. Care should be taken during the grouping of data and rule base generation to get an optimum output. Both these MFs have some advantage and disadvantages. In triangular MF the disadvantage is the sharp variation of parameter where as in the trapezoidal MF the disadvantage is that for a range of values (i.e. from hight-1 to hight-2) it assigns a MF value 1. We can also test the results using the Gaussian function.

So from the above comparison we are free to choose any MF in our choice and suitably model it to meet the criteria.

3.7 Discussion:

The fuzzy logic model was trained and it was tested for correctness and accuracy of model. Suitable care has been taken so that all the rules are fined correctly. Effectiveness of the model is verified using six sets of test data, those which are not incorporated for training purpose. The value of the breakdown voltage ($y = f(x_1, x_2, x_3)$) have been thus estimated for all six sets. Finally the MAE of the test data has been calculated using the relation

$$(\sum |T_s - O_s| / T_s) / s$$

In the present work the MAE for triangular MF & trapezoidal MF are found to be 1.4% & 1.324% respectively.

The FL model thus developed seems to be very effective for the estimation of breakdown voltage of insulation or insulation system with different insulation thickness and void dimensions.

3.8 Conclusion:

The FL implementation for modeling of breakdown voltage in solid dielectric is presented. It seems to provide an easier and a better computation technique. An immediate consequence of this work is that the dielectric can be analyzed at a virtually negligible computing cost. The proposed model indicates that the FL modeling could be well implemented for such kind of estimation with a reasonable accuracy. The computational complexities and training needs are such that this system can be implemented using available micro-controllers.

CHAPTER 4

PARAMETER ESTIMATION FOR THE WEIBULL FUNCTION DISTRIBUTION USING MAXIMUM LIKELIHOOD ESTIMATION (MLE)

After estimating the breakdown voltages by fuzzy logic we are now interested in finding the scale parameter (Θ) and shape parameter (β) by using the weibull function distribution. By using the weibull function the distribution “fit” to the experiment data well and confidence interval can be assigned to them. the data used in the previous experiment set up are extracted to be used here.

4.1 Introduction to weibull function

Now a day the weibull probability distribution has gained wide acceptance in the statistical treatment of the time to electrical breakdown of dielectrics. This distribution seems to “fit” experimental life data better than other statistical method. the ability of the weibull function to represent all kinds life data turns out to be a weakness as well. It happens when two set of different numerical data get similar parameters and vice versa. The parameters are relatively less sensitive to the random variable. In the graphical method used earlier, the estimate is subjective, observer sensitiveness and the confidence intervals are absent. Now many advances have been made in the techniques for estimating weibull parameters.

4.2 Weibull Function

The cumulative three variable weibull distribution functions is given by

$$F(t) = 1 - [-((t-\gamma)/\theta)^\beta] \dots\dots\dots (4.1)$$

where θ = scale parameter

β = shape parameter

γ =location parameter

t = random variable, usually the time to breakdown or electric field required to cause puncture of dielectric.(in this work time concept taken)

$F(t)$ =proportion of specimen initially tested which will fail by time t (voltage applied at $t=0$)

θ represent the time for $(1-e^{-1})$ on 6.3.2 percent of the tested units to fail.

β is a measure of dispersion of the failure time for $t=0$.

Γ is the time from application in which failure of any unit is not possible. (in the present case, of course $r=0$ has been taken).

θ, r has the dimension of time where the β is dimensionless.

By taking $r=0$, the equation(4.1) reduces to

$$F(t) = 1 - e^{-(t/\theta)^\beta}$$

Where θ and β are the properties of dielectric. If weibull parameters are compared to those of the normal and Gaussian distribution, then $\ln \theta$ and $(1/\beta)$ are analogous to the mean value and the standard deviation respectively. The scale parameter θ usually a function of the applied voltage when times to breakdown is a random variable, that is, when the voltage is increasing at constant rate or in step until the dielectric β .

4.3 Techniques for estimating weibull parameters

There are several techniques for estimation of weibull parameters, for example, monte-carlo simulations, maximum likelihood function, least square using Bernard and weibull rank estimation and white technique; apart from the graphical technique using a weibull probability. Out of these maximum likelihood estimate is most widely used and is proposed to be used in the present work.

4.3.1 Maximum likelihood estimate (MLE)

This method is the easiest and widely employed method for the calculation of weibull parameters θ and β from the experimental data applicable to any number with or without censoring. To apply the theory, a likelihood function is generated for the weibull distribution according to the procedure. This likelihood function is then maximized with respect to parameters of interest by setting its first derivative to zero. MLE can be implemented with the aid of a computer, when applied to a weibull distribution, this techniques yield the following relation for θ and β .

$$f(\beta) = A_2/A_1 - (1/\beta) - c = 0 \dots\dots\dots(4.2)$$

and

$$\theta = [A_1/n]^{(1/\beta)} \dots\dots\dots (4.3)$$

where $A_j = \sum T_i^\beta [\ln T_i]^{(j-1)} \dots\dots\dots (4.4)$ for $j=1,2,3$

while $c = (1/n) \sum \ln T_i \dots \dots \dots (4.5)$

where T_i = failure time for i th unit tested.

And n = number of samples tested.

The value of β can be estimated iteratively using Newton-Raphson procedure , with m representing the iteration number as;

$$\beta (m+1) = \beta(m) - f(\beta_m)/f'(\beta_m) \dots \dots \dots (4.6)$$

where

$$f'(\beta) = (1/\beta^2) + (A_3/A_1) - (A_2/A_1)^2 \dots \dots \dots (4.7)$$

The maximum likelihood estimate locus the visual impact of the graphical technique and are definitely superior to estimates obtained graphically.

4.4 Confidence intervals for the weibull parameter

The estimate of β and θ obtained from any single experiment and unlikely to equal the “true” of θ and β which would be obtained from an experiment involving an infinitely large number of specimens. Hence in addition to computing the estimates, each parameter was given a “Confidence interval”, which surrounds each estimated parameters. This interval is so formed that the true value of θ and β are within the given interval for all data sets.

Confidence interval for θ and β based on maximum likelihood function for uncensored data can be found .These apply to sample size from $h=n=5$.

For small censored experiments the table referred by S.ghosh is used here. These confidence interval can be applied to Maximum likelihood estimates as a good approximation. The 100(1-p) percent confidence interval for the shape parameters β is indicated by (**β_l and β_u**) where,

$$\beta_l = \beta W_{p/2}$$

$$\beta_u = W_{1-(P/2)}$$

The 100(1-p)Percent confidence interval for (α_l, α_u) where

$$\theta_l = \theta - \exp[(-V_{1-(P/2)}/\beta]$$

$$\theta_u = \theta \exp [(V_{p/2})/\beta]$$

4.5 Experimental results

θ and β values are calculated based on available data with S.ghosh.. Scale parameter θ and then confidence interval is calculated. Confidence interval 90% that is $(1-p=90\%)$ for the tested samples $n=5$ and failed samples for $n=5$.

From the corresponding table

$$\beta_l = \beta W_{p/2}$$

$$\beta_u = \beta W_{1-(P/2)}$$

$$W_{(P/2)} = W_{.05} = 0.36$$

$$W_{1-p/2} = W_{.95} = 1.5$$

$$\theta_l = \theta \exp[-(V_{1-(P/2)}/\beta)]$$

$$\theta_u = \theta \exp [(V_{p/2})/\beta]$$

$$V_{p/2} = V_{0.05} = -1.08$$

$$V_{(1-P/2)} = V_{0.95} = 1.2$$

θ and β for all the sets of input parameters and represented in the tabular format.

θ_l and θ_u represents the lower and upper limit of scale parameters which indicates that it is 90% sure that 63.2% of the test dielectric will fail between the given limit.

Table 4.1- calculation of shape parameters with confidence intervals

Thickness (mm)	Step time (sec)	β (shape parameter)	$\beta_u=1.5\beta$ (upper limit)	$\beta_l=0.36\beta$ (lower limit)	θ (scale parameter) (sec)	$\theta_u=\theta$ $e^{(1.08/\beta)}$ (upper limit)	$\theta_l=\theta$ $e^{(1.2/\beta)}$ (lower limit)
0.3	15	1.1080	1.662	0.3989	26.9	71.297	9.107
0.23	15	1.1281	1.692	0.406	26.2	68.25	9.043
0.18	15	1.1058	1.659	0.398	24.95	66.257	8.429
0.3	30	1.1220	1.683	0.404	51.2	34.063	17.57
0.23	30	1.0887	1.633	0.392	52.4	141.304	17.404
0.18	30	1.0882	1.632	0.3917	48.95	132.06	16.25
0.3	60	1.1126	1.699	0.401	101.5	267.94	34.519
0.23	60	1.1248	1.687	0.405	95.3	248.937	32.792
0.18	60	1.0988	1.648	0.396	92.2	246.374	30.934

4.6 Conclusion:

The weibull distribution is a general distribution that fit a wide variety of data. It is insensitive to apparently large deviations. Easiest method to calculate the weibull parameters θ and β is maximum likelihood technique. This requires a modest computer program. Confidence interval can be assigned to MLE θ and β .But these intervals can only be calculated for certain sample sizes and degrees of censoring. The parameters found out from MLE should be treated as approximate estimates. Since the double exponential nature of the weibull distribution results in inherently large confidence interval.

Chapter 5

ESTIMATION FOR LIFETIME OF LEATHERITE PAPER INSULATION USING STEP-STRESS TEST

5.1 Introduction

Accelerated ageing tests are widely accepted in testing of dielectric materials used in electrical appliances the soundness and stability of insulant can be accessed by life test there are two methods for this test-one is constant high voltage stress another is increasing the voltage at a constant rate or in steps until the dielectric is punctured .In first case the random variable is time and in the latter case the variable is complex function of time and voltage . A major drawback of constant stress method is that the test times are very long and tedious.

In the present case the lifetime of Leatherite paper is estimated using step-stress test.

5.2 Theory of step stress

The inverse power model has been frequently used to estimate the lifetimes of insulating materials under voltage stress. In the simplest form the model is described by the equation.

$$tv^n = K \dots \dots \dots (5.1)$$

where

t = time to breakdown at voltage stress v.

n and K are constants

Assuming a cumulative nature of the damage to insulation, the inverse power model may also be applied to step-stress test. In this procedure, the voltage is raised and hold constant at each step for some time interval. The cumulative damage is simply the sum of damages at each voltage level,

$$t_k (v_k) = \sum t_1 (v_i)^n + t_{i+1}(v_{i+1})^n \dots \dots \dots (5.2)$$

where

t_k = equivalent time to failure at voltage stress v_k .

$t_1 v_1$ = product of voltage and time at each completed step.

t_{i+1} =time of failure on the uncompleted v_{i+1} step.

We set the interval t_i in the experiment to be equal, the equation is simplified. The right hand side of the eqn(5.2) is treated at constant and independent of the time interval t_i , provided the ageing mechanism has not changed over the covered range. Using all the above data the exponent of the power model can easily determined by performing several tests.

5.3 Experimental procedure

The CIGRE-2 electrode geometry used for the breakdown voltage measurement. Electrodes used are made of brass. They were polished, buffed and cleaned with ethanol. The samples are prepared from commercially available insulation sheets. Three different thickness of the insulation i.e. 0.18, 0.23 and 0.3 are used. Before testing the conditioning procedure adopted to avoid surface discharges at lower voltage level. The applied voltage at 50 Hz.AC is obtained from a 60 kv discharge free testing transformer (siemens, AG). The voltage is raised in steps of 500 volt and total time of applied stress and the voltage at which breakdown occurs is noted. Five data points are obtained from each time interval of 15s,30s and 60 s are used for step-stress test. All the tests are carried out at NTP.

The physical Examination of the samples after breakdown test showed, in general that breakdown occurs at the center of insulation samples. Further, it is seen that breakdown voltages are lying within a class voltage range. A mean value of the five such breakdown voltages are taken for studies.

Weibull distribution was used to calculate the scale θ shape β and 90% confidence intervals of all data points.

5.4 Results

The breakdown points were normally distributed throughout the stressed area, although edge failures were more frequent with the step stress test. The results of the voltage endurance test are shown. The reported time represents the scale parameter of the weibull distribution from the data collected which is presented in the previous section. Three data points of the step stress test are shown in the figure, represent time to failure for intervals of 15s,30s and 60s. A linear fit was used to obtain the best fitting lines to data

points. From the slopes of these lines, the value of power exponent n is found out to be 4.7. For each interval the lifetime can $t v^n = k$ is calculated. These values were

$$K_{15} = 2.19 \times 10^4$$

$$K_{30} = 3.95 \times 10^4$$

$$K_{60} = 6.5 \times 10^4$$

Which are all of the same order magnitude. In the study the breakdown strength vary from 15.33kv/mm to 23.33kv/mm for 15 sec steps, 14.66kv/mm to 22.77kv/mm for 30 sec step and 14.33kv/mm to 21.66kv/mm for 60 sec step.

5.5 conclusions

Fast and reliable method of estimating of estimating the exponent of the power law can be a valuable asset in the ageing studies of the insulating materials. Such a technique is proposed using the step stress method. The assumption in this method is the cumulative damage theory. K_{15} K_{30} and K_{60} are found to be same order of magnitude.

Breakdown voltage is considered here without voids. Several theories of solid breakdown predict that breakdown strength is dependent directly upon insulation thickness. It is inherent that avalanche breakdown depends on the thickness. On the contrary, thermal breakdown caused by joule heating involves heat dissipation. The model has some limitation like –method is evaluated on a particular material in particular condition, valid for stress area covered by same mechanism. This work involves the inverse power law but other methods like exponential relation can be tested.

Chapter 6

GRAPHS & SURFACE PLOTS

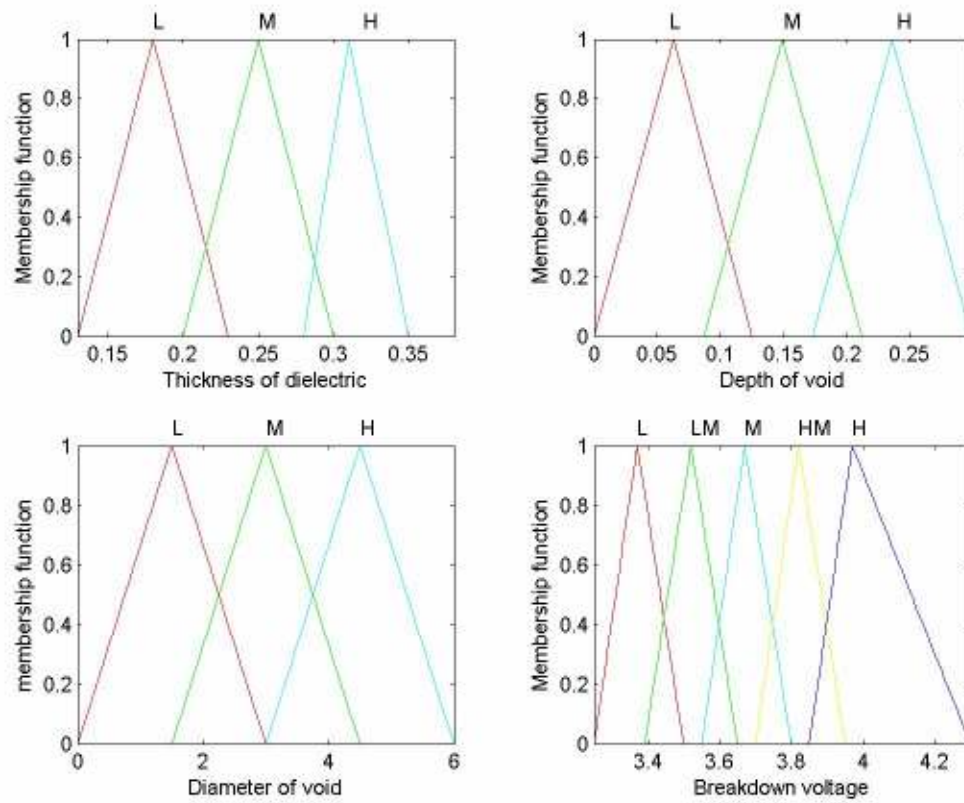

Fig 6.1 – Triangular membership function used in fuzzy modeling.

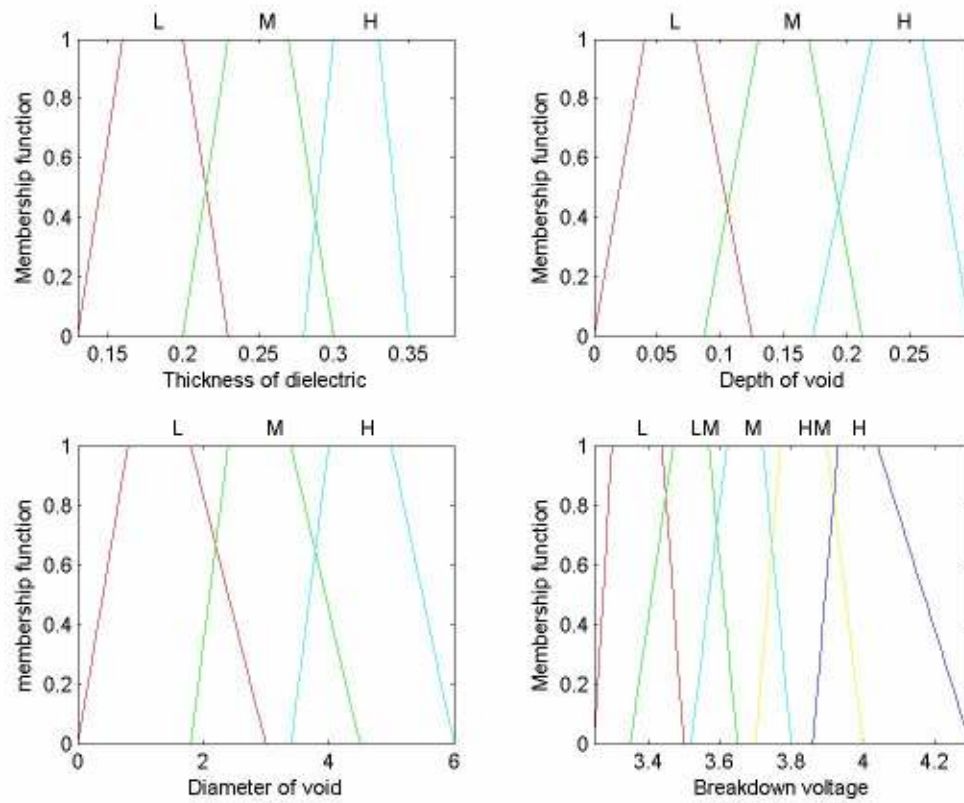

Fig 6.2 – trapezoidal membership function used in fuzzy modeling

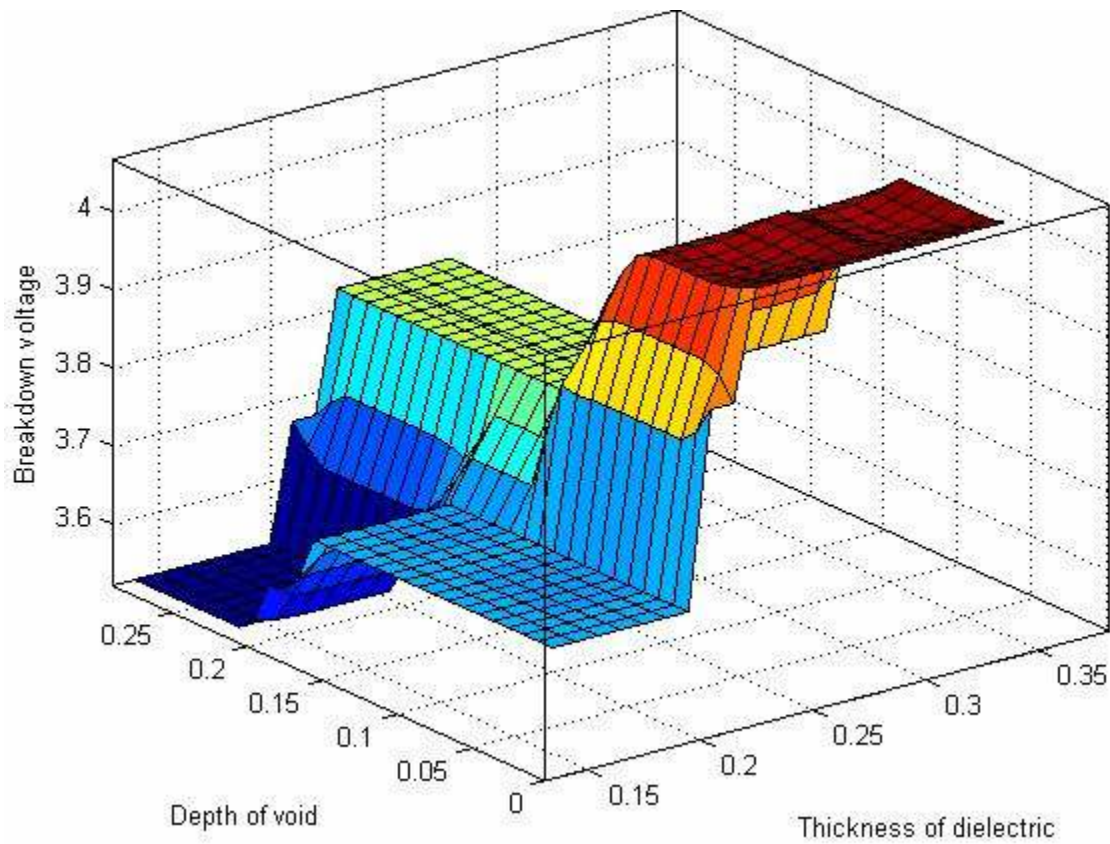

Fig 6.3 – Surface plot showing the variation of bdv with respect to depth of void and thickness of dielectric.(as used in fuzzy modeling).

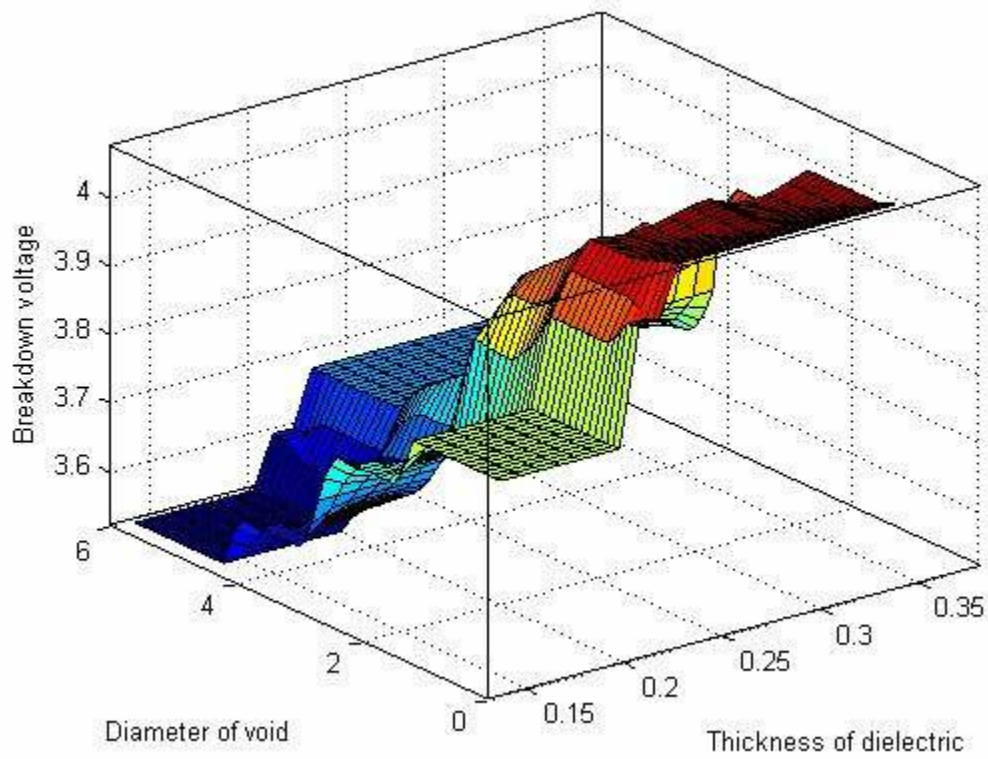

Fig 6.4 – Surface plot showing the variation of bdv with respect to thickness of dielectric and diameter of void.(as used in fuzzy modeling).

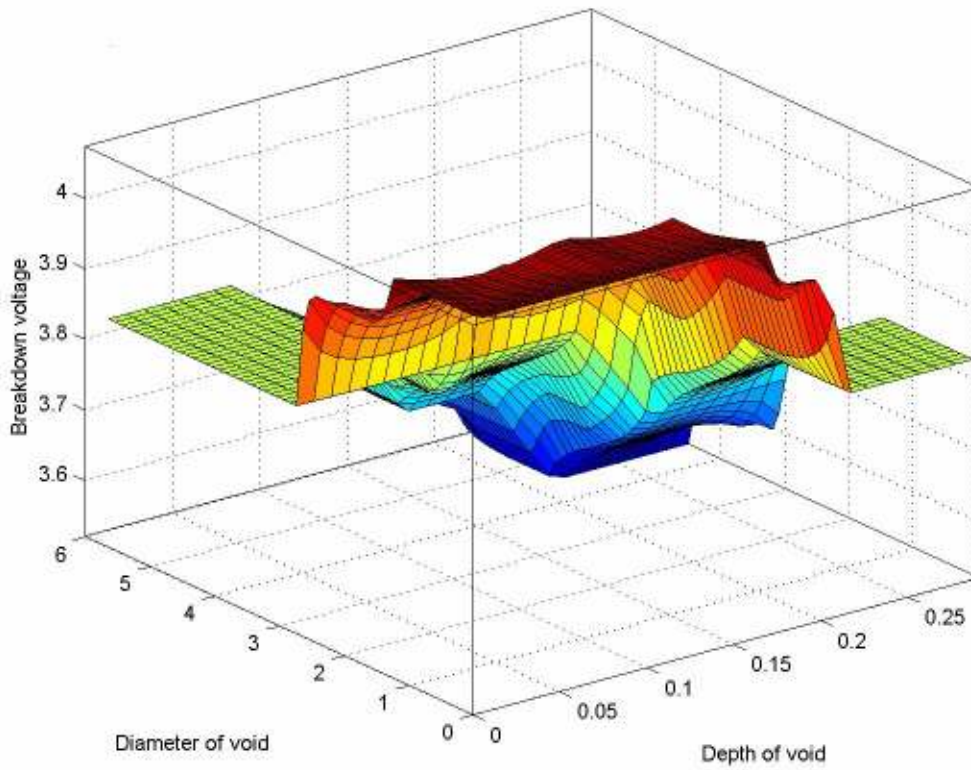

Fig 6.5 – Surface plot showing the variation of bdv with respect to depth of void and diameter of void.(as used in fuzzy modeling).

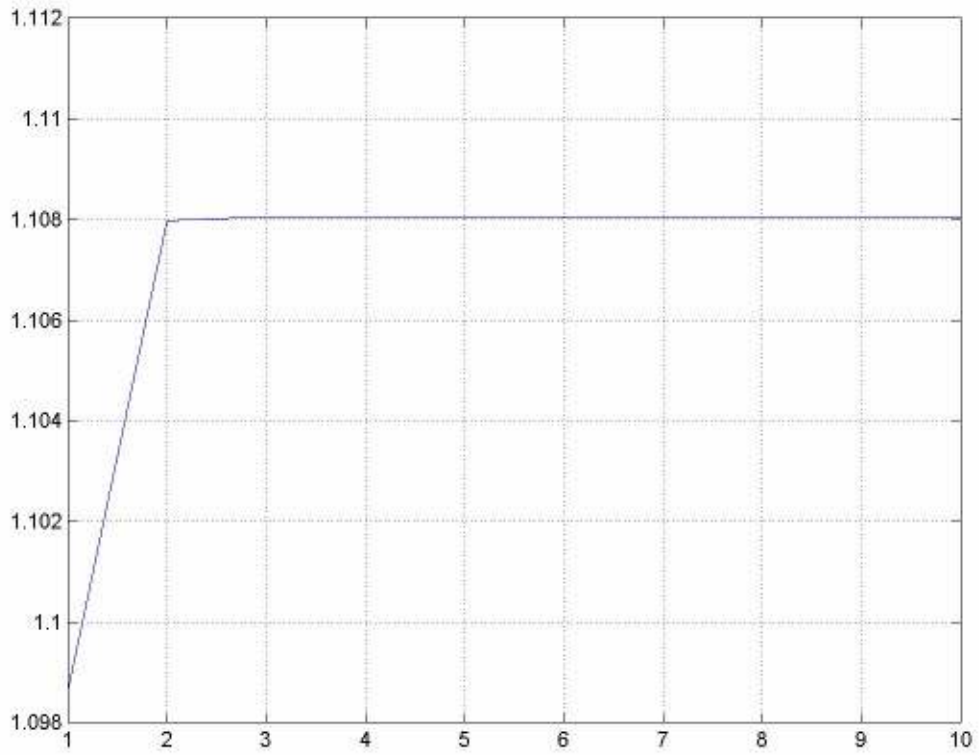

Fig 6.6 - Curve showing the convergence of the shape parameters with respect to the iteration count.(as used in weibull parameter estimations by MLE).

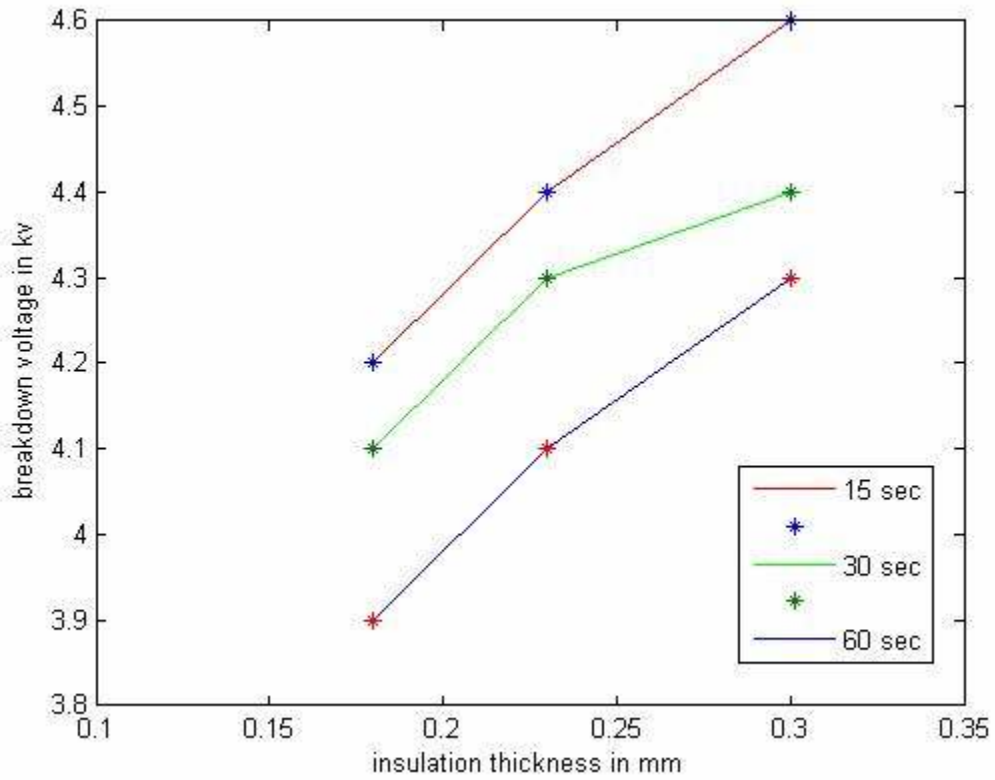

Fig 6.7 – Graph showing the variation of breakdown voltage with respect to the insulation thickness and with step stress.(as used in the life estimation experiment)

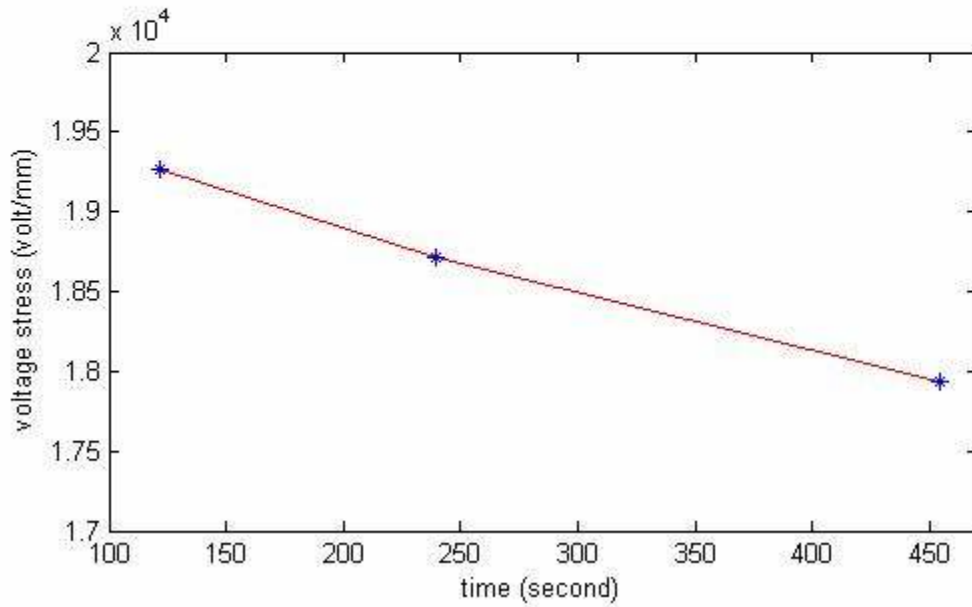

Fig 6.8 – Graph showing the variation of voltage stress with time in step stress in put. The slope of line n is to be calculated from this graph. Best fit technique is used.(as used in life estimation experiment)

Chapter 7

CONCLUSION

7.1 Introduction

After each chapter the detailed conclusions are given. The aim of this chapter to conclude the whole thesis and provide a generalized conclusion

7.2 Summary

Partial discharges caused in the insulation system by local defects, such as foreign partial inclusion, voids on inhomogenities. Electrical overstressing caused by defects contribute to the insulation degradation and breakdown. For the breakdown voids are the main culprits. So in this paper the effects of the void dimension on electrical breakdown is studied and from the results obtained, the weibull distribution the weibull distribution function is evaluated and consequently the life of insulation is estimated.

The FL implementation for modeling of breakdown voltage in solid dielectrics is presented. It seems to provide an easier and better computation techniques. An immediate consequence of this work is that the dielectric can be analyzed at virtually negligible cost. The accuracy of the method has been verified by estimating breakdown voltage for voids in the dielectrics, for which the experimental results are known, quite good matching of experimental and estimated results indicate that fuzzy logic modeling could be well implemented for such kind of estimation with reasonable accuracy.

After the successful estimation of the breakdown voltage by fuzzy logic modeling, the statistical analysis of the insulation breakdown is analysed. The weibull distribution, which is a general distribution that can fit a wide variety of data, is adopted for the analysis. The weibull parameter θ and β are found out by using MLE technique. The MLE technique is quite easy and has advantage over the graphical technique. Confidence intervals are assigned to MLE estimates of θ and β . But the limitation of this is that the intervals can only be used for certain fixed sizes. MLE estimate is treated as approximate estimate. By adopting the confidence interval of lower and upper limits of the scale parameter and shape parameters are obtained for 90% accuracy. The θ_l and θ_u i.e. the lower and upper limits of scale parameter indicates that 63.2% of the test dielectric will fail within the time interval θ_l to θ_u with 90% surety.

In the final step, it is tried to estimate the life of insulation with the help of weibull parameter data get from the previous section. The breakdown strength of the dielectric is also predicted. The insulation without voids is taken for life estimation and strength prediction. Breakdown voltage is found to be a function of insulation thickness. During the strength prediction is observed that breakdown voltage decreases quite appreciably when the step duration of accelerated step stress test increases. From the weibull parameters the life is estimated and K_{15} , K_{30} and K_{60} values are found out. But the method has some limitations like-particular material under particular condition is evaluated. This test should be performed in condition identical to the actual use. The data suggest that the requirement is met reasonably well over the voltage stress employed in the experiment, the work employed the inverse power law; the analysis can also be performed using the exponential relation.

7.3 Conclusion

The present project was started with the aim to estimate the breakdown voltage by analyzing the void and the insulation dimension with the help of Fuzzy logic modeling. Then it has been extended towards the weibull distribution. Though the software simulation yields good precision for the desired results but the actual environmental and cumulative degradation are not taken into account. The data sets were also validated for particular input and particular condition.

In the fuzzy logic modeling we have simulated Mamdani fuzzy logic with min-max algorithm and triangular & trapezoidal membership function. This can be function developed by using other algorithm and Membership functions. As we cannot claim about the optimality of the system, so it is better to model with all the available and algorithm and choose the best estimate.

Sugeno models and adaptive fuzzy logic are some of the recent trends. These also provide better estimation and better tuning techniques, so for the better validation and accuracy these techniques can be implemented in future.

REFERENCES

- [1]. Ghosh S., "Study of some aspects of Artificial Neural Network Modeling Partial discharge phenomenon" Ph.D Dissertation , IIT,Kharagpur , 2000
- [2] James J. Meary , "Rule combination and Fuzzy logic inference" IEEE Transaction on Fuzzy Logic, February 1992
- [3] JANG JSR, SUN,MIZUTANI "Neuro-Fuzzy & Soft Computing
- [4]Laghani J.R , Cpgan.p and Khocheh W. " A short method of estimating Lifetime Of polypropylene Film Using Step-Stress tests"
- [5] Stone G.c and Lawless J.F "The Application Weibull Statistics to Insulation Aging Tests" IEEE Trans. Electr Insul Vol 14, pp 233-239 1979
- [6]Stone G.C and Heeswijk Van R.G "Parameter estimation for the Weibull distribution " IEE Trans. Electr. Insul Vol E1-12, No4 , Aug 1977