

# **AUTOMATIC POWER FACTOR CORRECTION BY MICROCONTROLLER 8051**

A THESIS SUBMITTED IN PARTIAL FULFILLMENT OF THE  
REQUIREMENTS FOR THE DEGREE OF

**Bachelor of Technology**

in

**Electrical Engineering**

By

**SATYASURANJEET BEHERA  
SIBASIS MOHAPATRA  
MONALISA BISOI**



**Department of Electrical Engineering**

**National Institute of Technology**

**Rourkela**

2007

**AUTOMATIC POWER FACTOR CORRECTION BY  
MICROCONTROLLER 8051**

A THESIS SUBMITTED IN PARTIAL FULFILLMENT OF THE  
REQUIREMENTS FOR THE DEGREE OF

**Bachelor of Technology  
in  
Electrical Engineering**

By

**SATYASURANJEET BEHERA  
SIBASIS MOHAPATRA  
MONALISA BISOI**

Under the Guidance of

Prof. S. Ghosh



**Department of Electrical Engineering**

**National Institute of Technology**

**Rourkela**

2007



## **National Institute of Technology Rourkela**

### **CERTIFICATE**

This is to certify that the thesis entitled, "Automatic Power Factor Correction by Microcontroller 8051" submitted by Sri Satyasuranjeet Behera, Sibasis Mohapatra and Monalisa Bisoi in partial fulfillment of the requirements for the award of Bachelor of Technology Degree in Electrical Engineering at the National Institute of Technology, Rourkela (Deemed University) is an authentic work carried out by him under my supervision and guidance.

To the best of my knowledge, the matter embodied in the thesis has not been submitted to any other University/Institute for the award of any Degree or Diploma.

Date :

Place:

Prof. S. Ghosh

Dept. of Electrical Engg.

National Institute of technology

Rourkela-769008

## **ACKNOWLEDGEMENT**

I would like to articulate my deep gratitude to my project guide Prof. S. Ghosh who has always been my motivation for carrying out the project.

I wish to extend my sincere thanks to Prof. P. K. Nanda, Head of our Department, for approving the request for the financial aid to develop the model.

It is my pleasure to refer Microsoft Word exclusive of which the compilation of this report would have been impossible.

An assemblage of this nature could never have been attempted with our reference to and inspiration from the works of others whose details are mentioned in references section. I acknowledge my indebtedness to all of them. Last but not the least, my sincere thanks to all of my friends who have patiently extended all sorts of help for accomplishing this undertaking.

**SATYASURANJEET BEHERA**

**SIBASIS MOHAPATRA**

**MONALISA BISOI**

# CONTENT:

CHAPTERS	PAGE
1. Introduction.....	1
Background.....	2
2. Theory .....	3
Power Factor.....	4
Power Factor Correction.....	5
Static Correction.....	7
Supply harmonics.....	8
Supply resonance.....	9
3. Principle of design.....	11
Principle.....	12
Circuit Description.....	12
4. Modules.....	13
Power Supply.....	14
Zero crossing detector.....	15
Motherboard.....	15
Port assignment.....	18
Algorithm.....	18
Program.....	18
Function Generator.....	22
Relay Driver.....	34
LCD Display.....	36
5. Conclusion.....	37
Adverse effect of over correction.....	38
Advantages of improved power factor.....	38
Conclusion.....	38
6. References.....	39

# ABSTRACT

In the present technological revolution power is very precious. So we need to find out the causes of power loss and improve the power system. Due to industrialization the use of inductive load increases and hence power system losses its efficiency. So we need to improve the power factor with a suitable method. . When ever we are thinking about any programmable devices then the embedded technology comes into fore front. The embedded is now a day very much popular and most the product are developed with Microcontroller based embedded technology.

Automatic power factor correction device reads power factor from line voltage and line current by determining the delay in the arrival of the current signal with respect to voltage signal from the function generator with high accuracy by using an internal timer. This time values are then calibrated as phase angle and corresponding power factor. Then the values are displayed in the 2X16 LCD modules. Then the motherboard calculates the compensation requirement and accordingly switches on different capacitor banks. This is developed by using 8051 microcontroller.

Automatic power factor correction techniques can be applied to the industries, power systems and also house holds to make them stable and due to that the system becomes stable and efficiency of the system as well as the apparatus increases. The use of microcontroller reduces the costs.

# Chapter 1

## **INTRODUCTION**

Background

## **INTRODUCTION:**

### **BACKGROUND:**

In the present scenario of technological revolution it has been observed that the power is very precious. The industrialization is primarily increasing the inductive loading, the Inductive loads affect the power factor so the power system losses its efficiency. There are certain organizations developing products and caring R&D work on this field to improve or compensate the power factor. In the present trend the designs are also moving forwards the miniature architecture; this can be achieved in a product by using programmable device. When ever we are thinking about any programmable devices then the embedded technology comes into fore front. The embedded is now a day very much popular and most the product are developed with Microcontroller based embedded technology. The advantages of using the microcontroller is the reduction of the cost and also the use of extra hardware such as the use of timer, RAM and ROM can be avoided. This technology is very fast so controlling of multiple parameters is possible; also the parameters are field programmable by the user.

The electrical engineering and its applications are the oldest streams of Engineering. Though these systems are quite reliable and cheaper, it has certain disadvantages. The electro mechanical protection relays are too bulky and needs regular maintenance. The multifunctional is out of question. Recently, the technical revolution made embedded technology cheaper, so that it can be applied to all the fields. The pioneer manufactures of Power system and protection system such as SIMENS, LARSON & TUBRO, and CUTLER HAMPER etc. manufacturing power factor improvement devices on embedded technology.

The Automatic Power factor Correction device is a very useful device for improving efficient transmission of active power. If the consumer connect inductive load, then the power factor lags, when the power factor goes below 0.97(lag) then the Electric supply company charge penalty to the consumer. So it is essential to maintain the Power factor below with in a limit. Automatic Power factor correction device reads the power factor from line voltage and line current, calculating the compensation requirement switch on different capacitor banks.



# Chapter 2

## **THEORY**

Power factor  
Power factor correction  
Static correction  
Supply harmonics  
Supply resonance

## **THEORY:**

### **POWER FACTOR:**

Power factor is the ration between the KW and the KVA drawn by an electrical load where the KW is the actual load power and the KVA is the apparent load power. It is a measure of how effectively the current is being converted into useful work output and more particularly is a good indicator of the effect of the load current on the efficiency of the supply system.

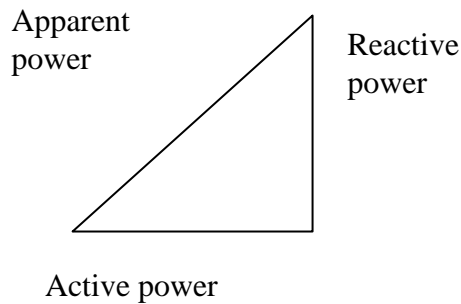

Fig 2.1

All current will cause losses in the supply and distribution system. A load with a power factor of 1.0 result in the most efficient loading of the supply and a load with a power factor of 0.5 will result in much higher losses in the supply system.

A poor power factor can be the result of either a significant phase difference between the voltage and current at the load terminals, or it can be due to a high harmonic content or distorted/discontinuous current waveform. Poor load current phase angle is generally the result of an inductive load such as an induction motor, power transformer, lighting ballasts, welder or induction furnace. A distorted current waveform can be the result of a rectifier, variable speed drive, switched mode power supply, discharge lighting or other electronic load.

A poor power factor due to an inductive load can be improved by the addition of power factor correction, but, a poor power factor due to a distorted current waveform requires a change in equipment design or expensive harmonic filters to gain an appreciable improvement. Many inverters are quoted as having a power factor of better than 0.95 when in reality, the true power factor is between 0.5 and 0.75. The figure of 0.95 is based on the Cosine of the angle between the voltage and current but does not take

into account that the current waveform is discontinuous and therefore contributes to increased losses on the supply.

### **POWER FACTOR CORRECTION:**

Capacitive Power Factor correction is applied to circuits which include induction motors as a means of reducing the inductive component of the current and thereby reduce the losses in the supply. There should be no effect on the operation of the motor itself.

An induction motor draws current from the supply that is made up of resistive components and inductive components.

The resistive components are:

- (i) Load current
- (ii) Loss current

The inductive components are

- (i) Leakage reactance
- (ii) Magnetizing current

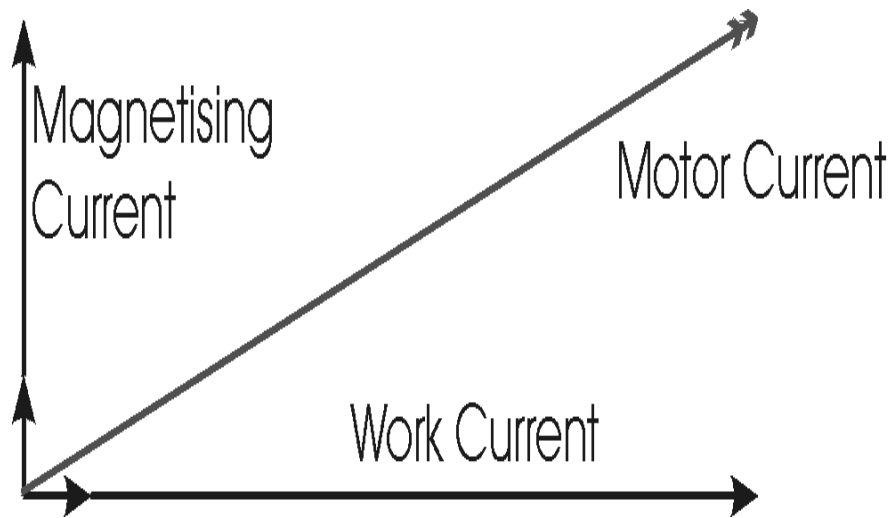

Fig 2.2

The current due to the leakage reactance is dependant on the total current drawn by the motor, but the magnetizing current is independent of the load on the motor. The magnetizing current will typically be between 20% and 60% of the rated full load current of the motor. The magnetizing current is the current that establishes the flux in the iron and is very necessary if the motor is going to operate. The magnetizing current

does not actually contribute to the actual work output of the motor. It is the catalyst that allows the motor to work properly. The magnetizing current and the leakage reactance can be considered passenger components of current that will not affect the power drawn by the motor, but will contribute to the power dissipated in the supply and distribution system.

Taking an example, a motor with a current draw of 100 Amps and a power factor of 0.75 the resistive component of the current is 75 Amps and this is what the KWh meter measures. The higher current will result in an increase in the distribution losses of  $(100 \times 100) / (75 \times 75) = 1.777$  or a 78% increase in the supply losses.

In the interest of reducing the losses in the distribution system, power factor correction is added to neutralize a portion of the magnetizing current of the motor. Typically, the corrected power factor will be 0.92 - 0.95 some power retailers offer incentives for operating with a power factor of better than 0.9, while others penalize consumers with a poor power factor. There are many ways that this is metered, but the net result is that in order to reduce wasted energy in the distribution system, the consumer will be encouraged to apply power factor correction.

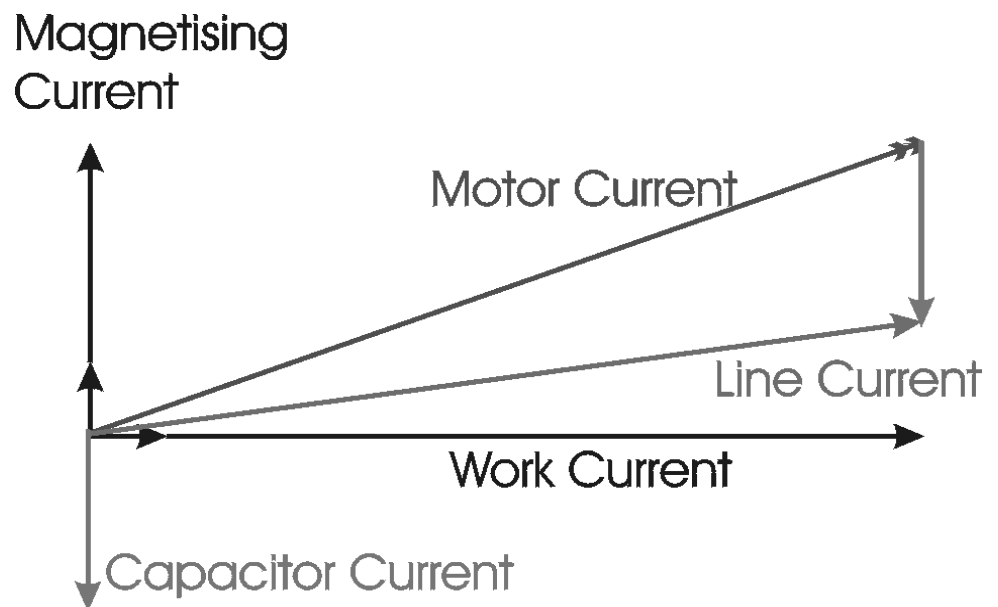

Fig 2.3

Power factor correction is achieved by the addition of capacitors in parallel with the connected motor circuits and can be applied at the starter, or applied at

the switchboard or distribution panel. The resulting capacitive current is leading current and is used to cancel the lagging inductive current flowing from the supply.

Capacitors connected at each starter and controlled by each starter are known as "Static Power Factor Correction".

### **STATIC CORRECTION:**

As a large proportion of the inductive or lagging current on the supply is due to the magnetizing current of induction motors, it is easy to correct each individual motor by connecting the correction capacitors to the motor starters. With static correction, it is important that the capacitive current is less than the inductive magnetizing current of the induction motor. In many installations employing static power factor correction, the correction capacitors are connected directly in parallel with the motor windings. When the motor is Off Line, the capacitors are also Off Line. When the motor is connected to the supply, the capacitors are also connected providing correction at all times that the motor is connected to the supply. This removes the requirement for any expensive power factor monitoring and control equipment. In this situation, the capacitors remain connected to the motor terminals as the motor slows down. An induction motor, while connected to the supply, is driven by a rotating magnetic field in the stator which induces current into the rotor. When the motor is disconnected from the supply, there is for a period of time, a magnetic field associated with the rotor. As the motor decelerates, it generates voltage out its terminals at a frequency which is related to its speed. The capacitors connected across the motor terminals, form a resonant circuit with the motor inductance. If the motor is critically corrected, (corrected to a power factor of 1.0) the inductive reactance equals the capacitive reactance at the line frequency and therefore the resonant frequency is equal to the line frequency. If the motor is over corrected, the resonant frequency will be below the line frequency. If the frequency of the voltage generated by the decelerating motor passes through the resonant frequency of the corrected motor, there will be high currents and voltages around the motor/capacitor circuit. This can result in severe damage to the capacitors and motor. It is imperative that motors are never over corrected or critically corrected when static correction is employed.

Static power factor correction should provide capacitive current equal to 80% of the magnetizing current, which is essentially the open shaft current of the motor.

The magnetizing current for induction motors can vary considerably. Typically, magnetizing currents for large two pole machines can be as low as 20% of the rated current of the motor while smaller low speed motors can have a magnetizing current as high as 60% of the rated full load current of the motor. It is not practical to use a "Standard table" for the correction of induction motors giving optimum correction on all motors. Tables result in under correction on most motors but can result in over correction in some cases. Where the open shaft current can not be measured, and the magnetizing current is not quoted, an approximate level for the maximum correction that can be applied can be calculated from the half load characteristics of the motor.

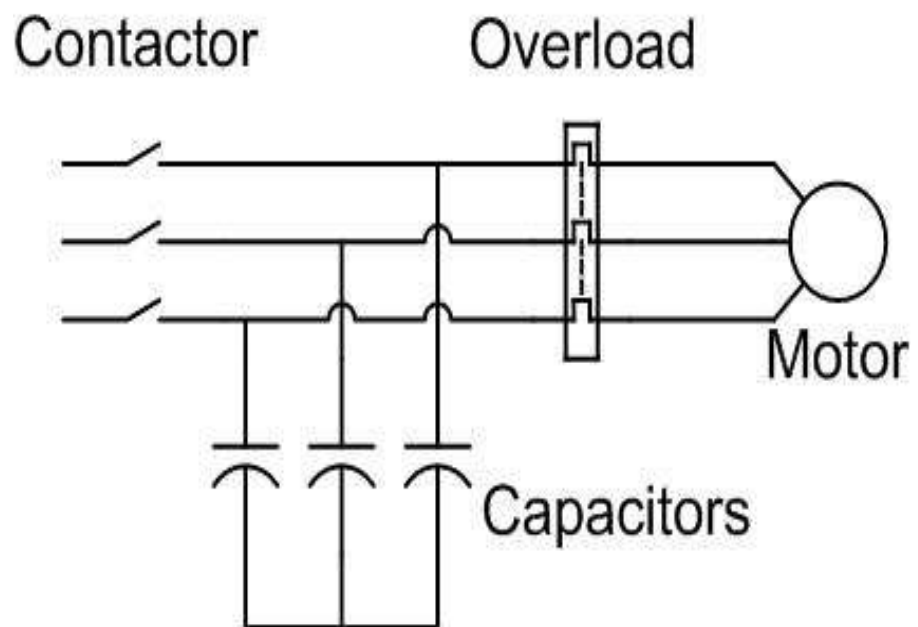

Fig 2.4

It is dangerous to base correction on the full load characteristics of the motor as in some cases, motors can exhibit a high leakage reactance and correction to 0.95 at full load will result in over correction under no load, or disconnected conditions.

Static correction is commonly applied by using one contactor to control both the motor and the capacitors. It is better practice to use two contactors, one for the motor and one for the capacitors. Where one contactor is employed, it should be

up sized for the capacitive load. The use of a second contactor eliminates the problems of resonance between the motor and the capacitors.

### **SUPPLY HARMONICS:**

Harmonics on the supply cause a higher current to flow in the capacitors. This is because the impedance of the capacitors goes down as the frequency goes up. This increase in current flow through the capacitor will result in additional heating of the capacitor and reduce its life.

The harmonics are caused by many non linear loads; the most common in the industrial market today, are the variable speed controllers and switch mode power supplies. Harmonic voltages can be reduced by the use of a harmonic compensator, which is essentially a large inverter that cancels out the harmonics. This is an expensive option. Passive harmonic filters comprising resistors, inductors and capacitors can also be used to reduce harmonic voltages. This is also an expensive exercise. In order to reduce the damage caused to the capacitors by the harmonic currents, it is becoming common today to install detuning reactors in series with the power factor correction capacitors. These reactors are designed to make the correction circuit inductive to the higher frequency harmonics. Typically, a reactor would be designed to create a resonant circuit with the capacitors above the third harmonic, but sometimes it is below.

Adding the inductance in series with the capacitors will reduce their effective capacitance at the supply frequency. Reducing the resonant or tuned frequency will reduce the effective capacitance further. The object is to make the circuit look as inductive as possible at the 5th harmonic and higher, but as capacitive as possible at the fundamental frequency. Detuning reactors will also reduce the chance of the tuned circuit formed by the capacitors and the inductive supply being resonant on a supply harmonic frequency, thereby reducing damage due to supply resonance amplifying harmonic voltages caused by non linear loads.

### **SUPPLY RESONANCE:**

Capacitive Power factor correction connected to a supply causes resonance between the supply and the capacitors. If the fault current of the supply is very high, the effect of the resonance will be minimal, however in a rural installation where

the supply is very inductive and can be high impedance, the resonance can be very severe resulting in major damage to plant and equipment.

To minimize supply resonance problems, there are a few steps that can be taken, but they do need to be taken by all on the particular supply.

1) Minimize the amount of power factor correction, particularly when the load is light. The power factor correction minimizes losses in the supply. When the supply is lightly loaded, this is not such a problem.

2) Minimize switching transients. Eliminate open transition switching - usually associated with generator plants and alternative supply switching, and with some electromechanical starters such as the star/delta starter.

3) Switch capacitors on to the supply in lots of small steps rather than a few large steps.

4) Switch capacitors on to the supply after the load has been applied and switch off the supply before or with the load removal.

Harmonic Power Factor correction is not applied to circuits that draw either discontinuous or distorted current waveforms.

Most electronic equipment includes a means of creating a DC supply. This involves rectifying the AC voltage, causing harmonic currents. In some cases, these harmonic currents are insignificant relative to the total load current drawn, but in many installations, a large proportion of the current drawn is rich in harmonics. If the total harmonic current is large enough, there will be a resultant distortion of the supply waveform which can interfere with the correct operation of other equipment. The addition of harmonic currents results in increased losses in the supply.

Power factor correction for distorted supplies can not be achieved by the addition of capacitors. The harmonics can be reduced by designing the equipment using active rectifiers, by the addition of passive filters (LCR) or by the addition of electronic power factor correction inverters which restore the waveform back to its undistorted state. This is a specialist area requiring either major design changes, or specialized equipment to be used.



# Chapter 3

## **PRINCIPLE OF DESIGN**

Principle  
Circuit description

## PRINCIPLE OF DESIGN:

### PRINCIPLE:

“Automatic Power Factor correction device is developed basing on a micro controller 89c51. The voltage and current sampled is converted in to square wave using a zero cross detector. The V and I sample signals are feed to the micro controller at INT0 and INT1 and the difference between the arrival of wave forms indicate the phase angle difference. The difference is measured with high accuracy by using internal timer. This time value is calibrated as phase angle and corresponding power factor. The values are displayed in the 2x16 LCD modules after converting suitably. The capacitor banks are switched as per the calibration in steps”.

### CIRCUIT DESCRIPTION:

#### BLOCK DIAGRAM OF AUTOMATIC POWERFACTOR

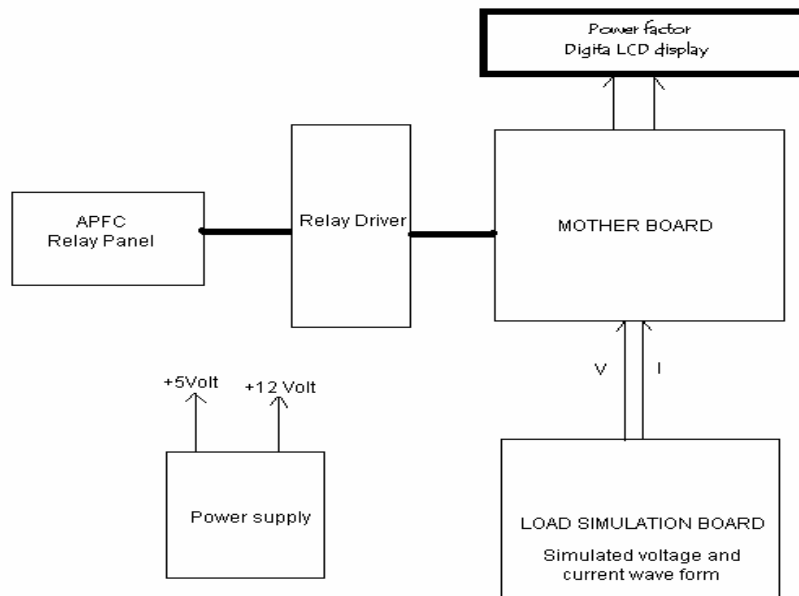

Fig 3.1

# Chapter 4

## **MODULES:**

- Power supply
- Zero crossing detector
- Motherboard
- Port Assignment
- Algorithm
- Function Generator
- Relay driver
- LCD Display

## MODULES:

### POWER SUPPLY:

In this power supply we are using step-down transformer, IC regulators, Diodes, Capacitors and resistors.

Explanation: - The input supply i.e., 230V AC is given to the primary of the transformer (Transformer is an electromechanical static device which transform one coil to the another without changing its frequency) due to the magnetic effect of the coil the flux is induced in the primary is transfer to the secondary coil. The output of the secondary coil is given to the diodes. Here the diodes are connected in bridge type. Diodes are used for rectification purposes. The out put of the bridge circuit is not pure dc, some what rippled ac is also present. For that capacitor is connected at the output of the diodes to remove the unwanted ac, capacitor are also used for filtering purpose. The both (-ve) terminal of the diode (D2 & D3) is connected to the (+ve) terminal of the capacitor and thus the input of the IC Regulator (7805 & 7812). Here we are using Voltage regulators to get the fixed voltage to our requirements.” Voltage regulator is a CKT that supplies a constant voltage regardless of changes in load currents. These IC’s are designed as fixed voltage regulators and with adequate heat sinking can deliver o/p currents in excess of 1A. The o/p of the IC regulator is given to the LED through resistors, When the o/p of the IC i.e , the voltage is given to the LED, it makes its forward bias and thus LED gloves on state and thus the +ve voltage is obtained.

Similarly , for –ve voltage ,here the both +ve terminals of the diodes(D1 & D4) is connected to the –ve terminals of the capacitors and thus to the I/p of the IC regulator with respect to ground. The o/p of the IC regulator(7912) which is a –ve voltage is given to the terminal of LED, through resistor, which makes it forward bias, LED conducts and thus LED gloves in ON state and thus the –ve voltage is obtained. The mathematical relation for ac input and dc output is

$$V_{dc}=V_m/3.141 \quad (\text{before capacitor})$$

$$V_d=V_m \quad (\text{after capacitor})$$

# POWER SUPPLY

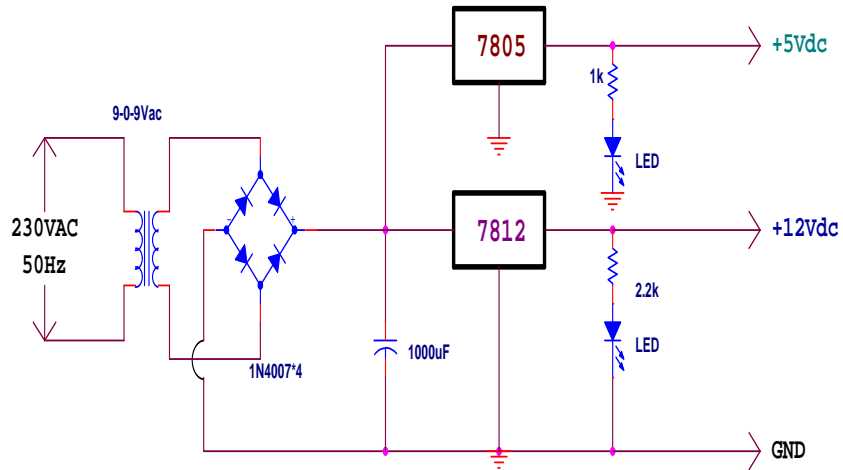

Fig 4.1

The capacitors ratings are chosen consider the voltage and current ratings of the power supply.

## ZERO CROSSING DETECTOR:

The zero crossing detector is a sine-wave to square-wave converter. The reference voltage in this case is set to zero.

The output voltage waveform shows when and in what direction an input signal crosses zero volt. If input voltage is a low frequency signal, then output voltage will be less quick to switch from one saturation point to another. And if there is noise in between the two input nodes, the output may fluctuate between positive and negative saturation voltage  $V_{sat}$ . Here IC 311 is used as a zero crossing detector.

## MOTHERBOARD:

Despite it's relatively old age, the 89C51 is one of the most popular Microcontroller in use today. Many derivatives Microcontroller have since been developed that are based on--and compatible with--the 8051. Thus, the ability to program an 89C51 is an important skill for anyone who plans to develop products that will take advantage of Microcontroller.

# MOTHER BOARD

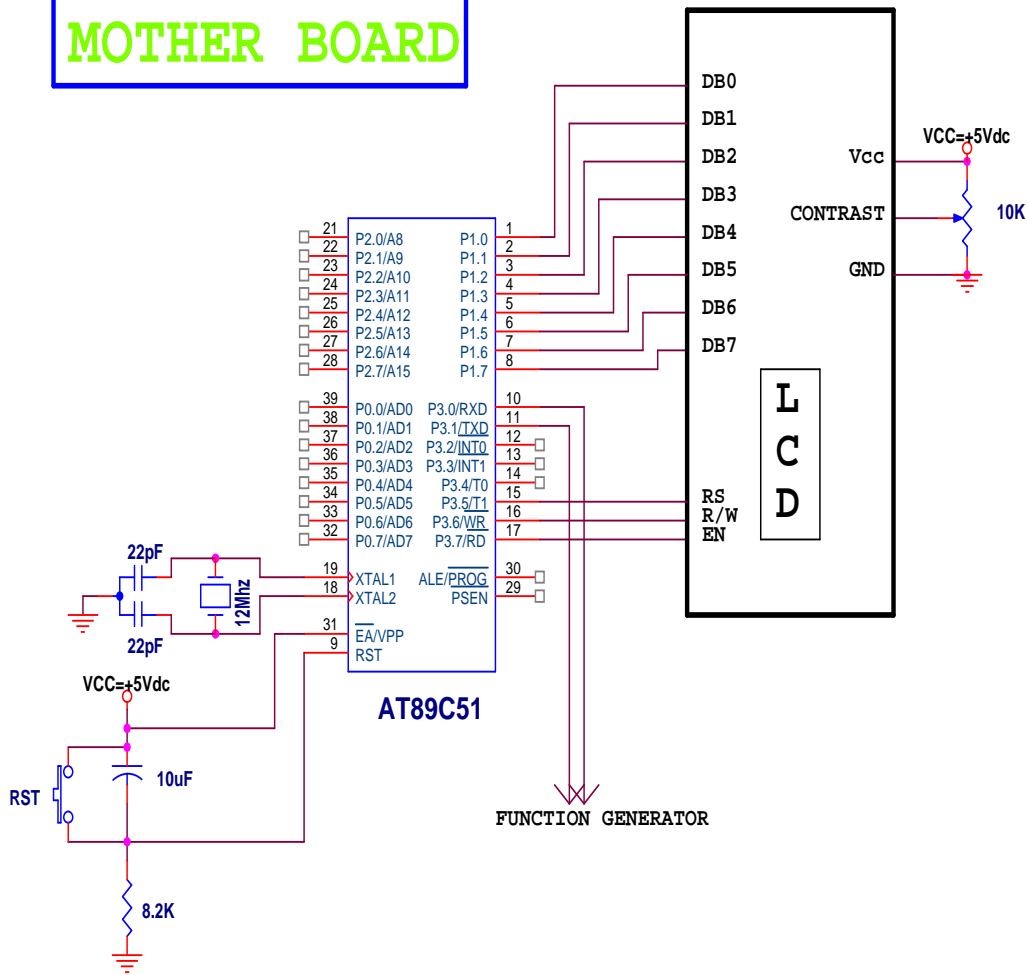

Fig 4.2

The 89C51 has three very general types of memory. To effectively program the 8051 it is necessary to have a basic understanding of these memory types.

The memory types are illustrated in the following graphic. They are: On-Chip Memory, External Code Memory, and External RAM.

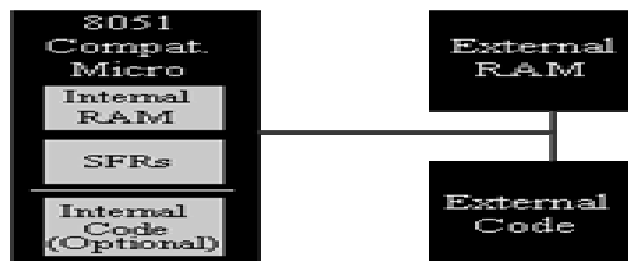

Fig 4.3

On-Chip Memory refers to any memory (Code, RAM, or other) that physically exists on the Microcontroller itself. On-chip memory can be of several types, but we'll get into that shortly.

External Code Memory is code (or program) memory that resides off-chip. This is often in the form of an external EPROM.

External RAM is RAM memory that resides off-chip. This is often in the form of standard static RAM or flash RAM.

IRAM Addr									Description
00	R0	R1	R2	R3	R4	R5	R6	R7	Reg. Bank 0
08	R0	R1	R2	R3	R4	R5	R6	R7	Reg. Bank 1
10	R0	R1	R2	R3	R4	R5	R6	R7	Reg. Bank 2
18	R0	R1	R2	R3	R4	R5	R6	R7	Reg. Bank 3
20	00	08	10	18	20	28	30	38	Bits 00-3F
28	40	48	50	58	60	68	70	78	Bits 40-7F
30	<p style="text-align: center;">General User RAM &amp; Stack Space (80 bytes, 30h-7Fh)</p>								General IRAM
7F									
80									
⋮	<p style="text-align: center;">Special Function Registers (SFRs) (80h - FFh)</p>								SFRs
⋮									
⋮									

Fig 4.4

The Microcontroller design consist of two parts

(i)Hardware.

(ii)Software.

**(i)HARDWARE:**

The controller operates on +5 V dc, so the regulated +v 5 v is supplied to pin no. 40 and ground at pin no. 20. The controller is used here need not required to handle high frequency signals, so as 4 MHz crystal is used for operating the processor. The pin no. 9 is supplied with a +5V dc through a push switch. To reset the

processor .As prepare codes are store in the internal flash memory the pin no. 31 is connected to + Vcc.

**PORT ASSIGNMENT:**

Port 1:-Input to LCD.

Port 2:- Input to relay driver

Port3.0 & Port3.1:- Input port from the function generator.

P1.6 is used as input port increment

P1.7 is used as on input port decrement

**(ii)SOFTWARE:**

**ALGORITHM:**

**(a)Altering phase of two signals**

Step-1:- Timer0 set and run till Timer1 is set or vice-versa.

Step-2:- Two signals (current & voltage) are introduced.

Step-3:- Phase angle between the two signals altered by incrementing or decrementing delay between two.

Step-4:- Delay of 0.1 ms is given while incrementing or decrementing.

Step-5:- Accumulator stores the number of incrementing or decrementing operations.

Step-6:- Delay is called according to the number stored in the accumulator.

Step-7:- The signals, altered in phase are sent to the motherboard for power factor detection.

**PROGRAM:**

```
$mod51
    org 0000h
    mov r0,#00h
    mov p0,#00h
    clr a
    ljmp main
    org 000bh
    acall timer
```



```
    reti
    org 001bh
    acall time0
    setb tr1
    reti
    org 0050h
time0:
    cpl p1.1
    mov tl1,#0dfh    ;e5h
    mov th1,#0b1h    ;f5h
    ret
    org 0070h
timer:
    cpl p1.0
    mov tl0,#0dfh
    mov th0,#0b1h
    setb tr0
    ret
    org 0100h
main:
    clr 00
    mov p1,#00h
    setb p1.7
    setb p1.6
    mov ie,#10001010b
    mov tmod,#11h
    mov tl0,#0dfh
    mov th0,#0b1h
    mov tl1,#0dfh
    mov th1,#0b1h
    setb p1.0
```

```
    setb tr0
here1:
    cjne r0,#00h,pass
    setb p1.1
    setb tr1
    sjmp here
pass: ]
    acall delay1
    djnz r0,pass
    sjmp here1
here:
    jb p1.7,here2
stay:
    jnb p1.7,stay
    cjne a,#10h,xx
    clr a
    mov r0,#00h
    sjmp main
xx:
    acall delay
    inc a
    mov r0,a
    mov p0,a
    clr tr0
    clr tr1
    setb p0.7
    sjmp main
here2:
    jb p1.6,here
stay1:
    jnb p1.6,stay1
```

```
    cjne a,#00h,yy
    sjmp here
yy:
    acall delay
    dec a
    mov r0,a
    mov p0,a
    clr tr0
    clr tr1
    sjmp main
delay1:
kk:
    mov r1,#100d
l1:
    djnz r1,l1
    ret
delay:
    mov r7,#100d
zz:
    mov r6,#100d
ww:
    mov r5,#50d
qq:
    djnz r5,qq
    djnz r6,ww
    djnz r7,zz
    ret
end
```

# FUNCTION GENERATOR

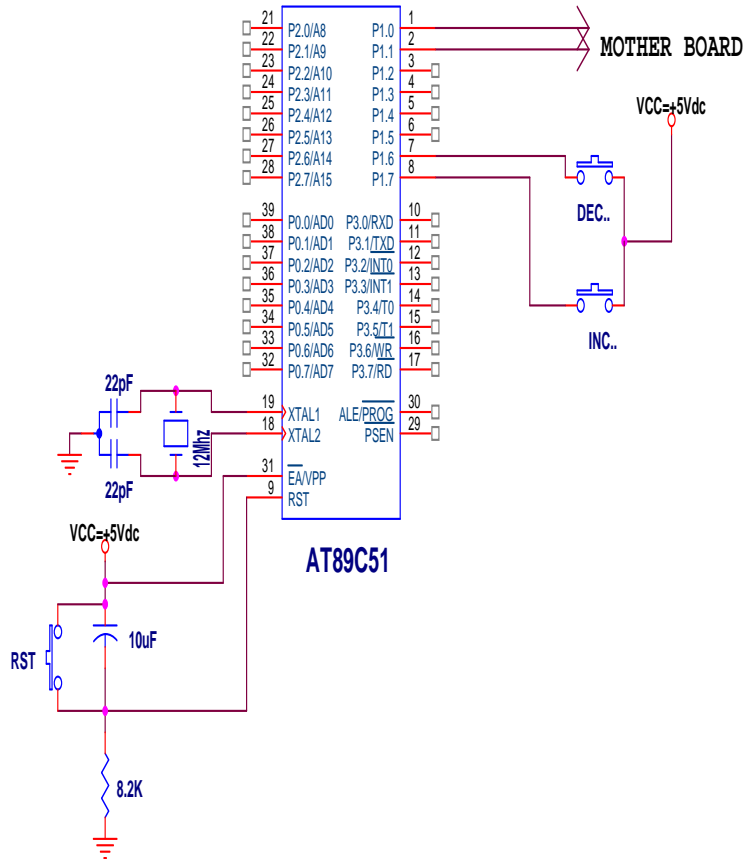

Fig 4.4

## (b) Phase angle Detection:

Step-1:- Microcontroller started on interrupt mode.

Step-2:-INTX0 & INTX1 are enabled.

Step-3:-INTX0 given VOLTAGE (V), INTX1 given CURRENT (I) from sampling circuit.

Step-4:-Timer measures time interval between two interrupts.

Step-5:-Time interval calibrated as 0-5ms = 0-90 degree.

Step-6:-Calibrated data is converted from HEX to BCD, then to ASCII for display on LCD.

**PROGRAM:**

```
$mod51
org 0000h
ljmp main
org 0003h
lcall back1
reti
org 0013h
lcall back
reti
org 0050h
back1:  jb 01,pass
        setb tr0
        setb 00h
        ret
pass:   clr tr0
        clr tf0
        mov a,#00h
        ret
org 0100h
back:   jb 00,pass1
        setb tr0
        setb 01h
        ret
pass1:  clr tr0
        clr tf0
        mov a,#00h
        ret
org 01a0h
main:
        mov r0,#00h
```

```
mov r3,#00h
mov r4,#00h
mov r5,#00h
mov p1,#00h
mov p0,#00h
mov p3,#0ffh
mov p2,#00h
mov r1,#00h
mov r2,#00h
mov r7,#00h
mov tmod,#01h
mov th0,#00h
mov tl0,#00h
setb tcon.2
setb tcon.0
clr tr0
clr tf0
clr 00
clr 01
clr p3.1
mov ie,#10000101b
mov a,#0ffh
```

main1:

```
cjne a,#00h,ss
mov ie,#00h
mov r1,tl0
mov r2,th0
;acall dispinit
;acall deci
acall scan
acall deci
```

```

;acall delay
clr 00h
clr 01h
mov th0,#00h
mov tl0,#00h
mov a,#0ffh
mov ie,#10000101
ss:  sjmp main1
deci: jb 00,laag
      acall lead_ang
      ret
laag: acall lag_ang
      ret
lead_ang: mov dptr,#msg12
          mov a,#0c0h
          acall prtcmd
          acall again
          ret
lag_ang: mov dptr,#msg13
          mov a,#0c0h
          acall prtcmd
          acall again
          ret
scan:
      cjne r2,#05h,go
      mov a,r1
      subb a,#0ddh ;aah
      jc com1
      mov dptr,#msg1
      acall disp
      ret

```

```

com1: clr c
      mov a,r1
      subb a,#078h
      jc com2
      mov dptr,#msg2
      acall disp
      jb p2.6,bypass3
      setb p2.6;relay4 on
bypass3: ret
com2:  clr c
      mov a,r1
      subb a,#14h
      jc thu
      mov dptr,#msg3
      acall disp
      ret
go:   cjne r2,#04h,go1
      mov a,r1
      subb a,#0b0h
      jc com3
thu:  clr c
      mov dptr,#msg4
      acall disp
      jb p2.4,bypass2
      setb p2.4;relay3 on
bypass2: ret
com3:  clr c
      mov a,r1
      subb a,#4ch
      jc wed
      mov dptr,#msg5

```



```

        acall disp
        ret
go1:    cjne r2,#03h,go2
        mov a,r1
        subb a,#0e8h
        jc com4
wed:    clr c
        mov dptr,#msg6
        acall disp
        jb p2.2,bypass1
        setb p2.2;relay2 on
bypass1: ret
com4:   clr c
        mov a,r1
        subb a,#20h
        jc tue
        mov dptr,#msg7
        acall disp
        ret
go2:    cjne r2,#02h,go3
        mov a,r1
        subb a,#0bch
        jc com5
tue:    clr c
        mov dptr,#msg8
        acall disp
        jb p2.0,bypass
        setb p2.0;relay1 on

bypass: ret
com5:   clr c

```

```

    mov a,r1
    subb a,#58h
    jc mon
    mov dptr,#msg9
    acall disp
    ret
go3:  cjne r2,#01h,go4
    mov a,r1
    subb a,#90h
    jc com6
mon:  clr c
    mov dptr,#msg10
    acall disp
    ret
com6: clr c
    mov dptr,#msg11
    acall disp; acall deci
    acall chk; acall delay
    ret
go4:  cjne r2,#00h,go5
    mov dptr,#msg11
    acall disp
    ; acall chk
    ; acall delay
    ret
go5:  mov dptr,#msg1
    acall disp
    ret
dispinit: mov a,#38h
    acall prtcmd
    mov a,#0eh

```

```

    acall prtcmd
    mov a,#06h
    acall prtcmd
    mov a,#01h
    acall prtcmd
    ret
disp:  acall dispinit
again: clr a
       movc a,@a+dptr
       jz next1
       acall prtchr
       inc dptr
       sjmp again
next1: ret
prtcmd: ACALL READY    ;is LCD ready?
        MOV  P1,A      ;issue command code
        CLR  P3.5      ;RS=0 for command
        CLR  P3.6      ;R/W=0 to write to LCD
        SETB P3.7      ;E=1 for H-to-L pulse
        CLR  P3.7      ;E=0 ,latch in
        RET
prtchr: ACALL READY    ;is LCD ready?
        MOV  P1,A      ;issue data
        SETB P3.5      ;RS=1 for data
        CLR  P3.6      ;R/W=0 to write to LCD
        SETB P3.7      ;E=1 for H-to-L pulse
        CLR  P3.7      ;E=0, latch in
        RET
READY:
        SETB P1.7      ;make P1.7 input port
        CLR  P3.5      ;RS=0 access command reg

```

```
SETB P3.6 ;R/W=1 read command reg
;read command reg and check busy flag
```

BACK11:

```
CLR P3.7 ;E=1 for H-to-L pulse
SETB P3.7 ;E=0 H-to-L pulse
JB P1.7,BACK11 ;stay until busy flag=0
RET
```

chk: jnb p2.0,chk1

```
clr p2.0
acall delay
ret
```

chk1:

```
jnb p2.2,chk2
clr p2.2
acall delay
ret
```

chk2:

```
jnb p2.4,chk3
clr p2.4
acall delay
ret
```

chk3:jnb p2.6,chk4

```
clr p2.6
acall delay
ret
```

chk4:ret

delay:

```
setb psw.3
setb psw.4
mov r3,#200d
```

```
zz: mov r4,#50d
ww: mov r5,#50d
qq: djnz r5,qq
    djnz r4,ww
    djnz r3,zz
    clr psw.3
    clr psw.4
    ret
msg1:
    db ' out of range '
    db 0
msg2:
    db ' P.F = 0.91 '
    db 0
msg3:
    db ' P.F = 0.92 '
    db 0
msg4:
    db ' P.F = 0.93 '
    db 0
msg5:
    db ' P.F = 0.94 '
    db 0
msg6:
    db ' P.F = 0.95 '
    db 0
msg7:
    db ' P.F = 0.96 '
    db 0
msg8:
    db ' P.F = 0.97 '
```

```

db 0
msg9:
db ' P.F = 0.98 '
db 0
msg10:
db ' P.F = 0.99 '
db 0
msg11:
db ' P.F is unity '
db 0
msg12:
db ' lead '
db 0
msg13:
db ' lag '
db 0
end

```

**RELAY DRIVER:**

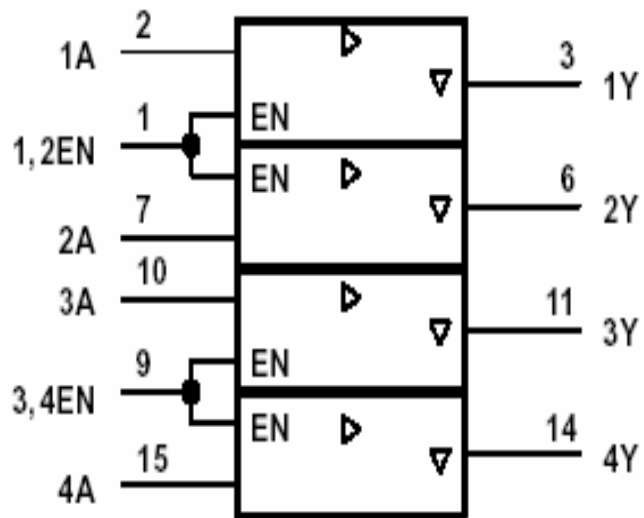

(L293D relay driver)

Fig 4.6

The relay driver is L293D. The relay used here having the specification as follows,

Coil resistance = 400ohm

Coil voltage = 12Vdc

Contact capacity = 230V, 7A

The above specification indicates that the coil requires 12V dc and 200mA current dc. The Microcontroller can't supply more than 10mA current. So driver section is very much required. L293D has a typical maximum output current of 600mA under normal conditions of temperature.

### ELECTRO MAGNETIC RELAY:

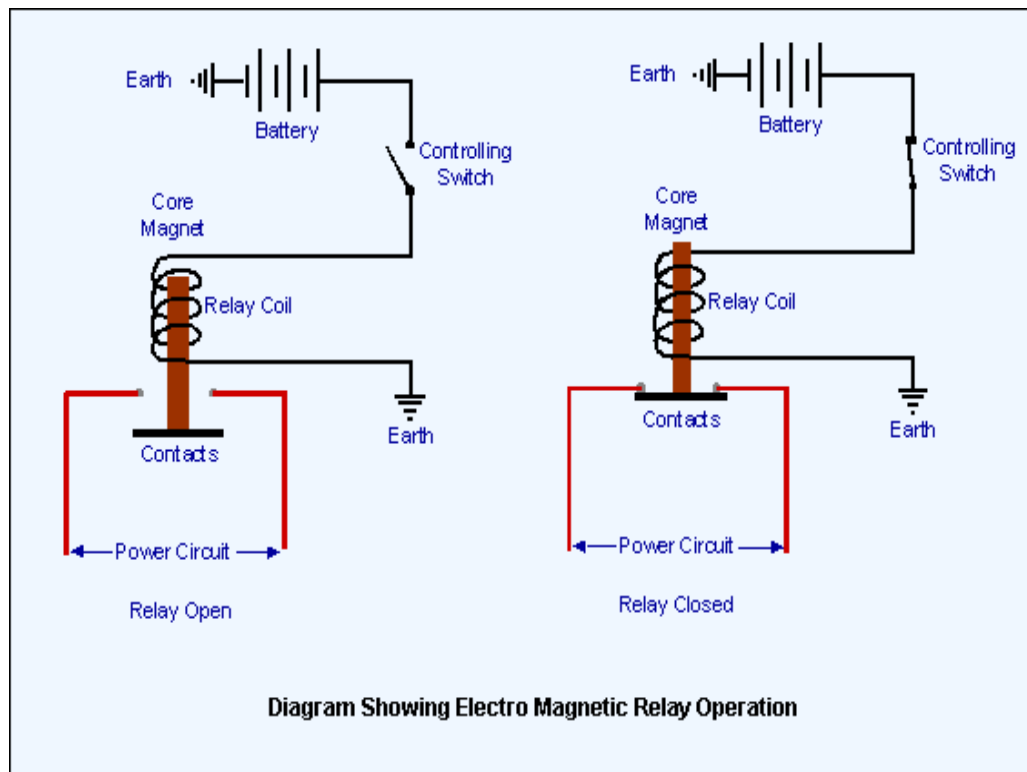

Fig 4.7

These are varying much reliable devices and widely used on field. The operating frequency of these devices are minimum 10-20ms. That is 50Hz – 100Hz. The relay which is used here can carry 25mA currents continuously. The electromagnetic relay operates on the principle magnetism. When the base voltage appears at the relay driver section, the driver transistor will be driver transistor will be

driven into saturation and allow to flow current in the coil of the relay, Which in turn create a magnetic field and the magnetic force produced due to that will act against the spring tension and close the contact coil.

Whenever the base voltage is withdrawn the transistor goes to cutoff .So no current flow in the coil of the relay. Hence the magnetic field disappears so the contact point breaks automatically due to spring tension. Those contact points are isolated from the low voltage supply, so a high voltage switching is possible by the help of electromagnetic relays.

The electromagnetic relays normally having 2 contact points. Named as normally closes (NC) , normally open (NO). Normally closed points will so a short CKT path when the relay is off. Normally open points will so a short CKT path when the relay is energized.

#### **LCD (LIQUID CRYSTAL DISPLAY):**

LCD panel consists of two patterned glass panels in which crystal is filled under vacuum. The thickness of glass varies according to end use. Most of the LCD modules have glass thickness in the range of 0.70 to 1.1mm.



Fig 4.8

Normally these liquid crystal molecules are placed between glass plates to form a spiral stair case to twist the twist the light. Light entering the top plate twist 900 before entering the bottom plate. Hence the LCDs are also called as optical switches. These LCD cannot display any information directly. These act as an interface



between electronics and electronics circuit to give a visual output. The values are displayed in the 2x16 LCD modules after converting suitably.

The liquid crystal display (LCD), as the name suggests is a technology based on the use of liquid crystal. It is a transparent material but after applying voltage it becomes opaque. This property is the fundamental operating principle of LCDs.

TN (Twisted nematics)

STN (Super twisted nematic)

# Chapter 5

## **CONCLUSION**

Adverse effect of over correction  
Advantages of improved power  
factor  
Conclusion

**ADVERSE EFFECT OF OVER CORRECTION:**

- Power system becomes unstable
- Resonant frequency is below the line frequency
- Current and voltage increases

**ADVANTAGES OF IMPROVED POWER FACTOR:**

- Reactive power decreases
- Avoid poor voltage regulation
- Overloading is avoided
- Copper loss decreases
- Transmission loss decreases
- Improved voltage control
- Efficiency of supply system and apparatus increases

**CONCLUSION:**

It can be concluded that power factor correction techniques can be applied to the industries, power systems and also house holds to make them stable and due to that the system becomes stable and efficiency of the system as well as the apparatus increases. The use of microcontroller reduces the costs. Due to use of microcontroller multiple parameters can be controlled and the use of extra hard wares such as timer,RAM,ROM and input output ports reduces. Care should be taken for overcorrection otherwise the voltage and current becomes more due to which the power system or machine becomes unstable and the life of capacitor banks reduces.

# Chapter 6

**REFERENCES**

## REFERENCES:

- P. N. Enjeti and R martinez, “A high performance single phase rectifier with input power factor correction ,”IEEE Trans. Power Electron..vol.11,No.2,Mar.2003.pp 311-317
- J.G. Cho,J.W. Won,H.S. Lee , “Reduced conduction loss zero-voltage-transition power factor correction converter with low cost,”IEEE Trans.Industrial Electron..vol.45,no 3,Jun. 2000,pp395-400
- “The 8051 Microcontroller and Embedded Systems” by Muhammad Ali Mazidi and Janice Gillispie Mazidi
- 8052 simulator for windows version 3.604 25Jun1999,sim8052@vaultbbs.com
- [www.fsinc.com](http://www.fsinc.com)
- [www.keil.com](http://www.keil.com)
- Eleetric power industry reconstructing in India,Present scenario and future prospects,S.N. Singh ,senior member,IEEE and S.C. Srivastava,Senior Member,IEEE
- “Power factror correction”, Reference design from Freescale <http://www.freescale.com>

# **AUTOMATIC POWER FACTOR CORRECTION**

Satyasuranjeet Behera, Sibasis Mohapatra & Monalisa Bisoi  
Supervision: Prof. S. Ghosh

## **Abstract**

Automatic power factor correction device reads power factor from line voltage and line current by determining the delay in the arrival of the current signal with respect to voltage signal from the function generator with high accuracy by using an internal timer. This time values are then calibrated as phase angle and corresponding power factor. Then the values are displayed in the 2X16 LCD modules. Then the motherboard calculates the compensation requirement and accordingly switches on different capacitor banks. This is developed by using 8051 microcontroller.

## **Introduction**

In the present technological revolution power is very precious. So we need to find out the causes of power loss and improve the power system. Due to industrialization the use of inductive load increases and hence power system losses its efficiency. So we need to improve the power factor with a suitable method. . When ever we are thinking about any programmable devices then the embedded technology comes into fore front. The embedded is now a day very much popular and most the product are developed with Microcontroller based embedded technology

## **Experimental**

### **POWER SUPPLY:**

In this power supply we are using step-down transformer, IC regulators, Diodes, Capacitors and resistors.

### **ZERO CROSSING DETECTOR:**

The zero crossing detector is a sine-wave to square-wave converter. The reference voltage in this case is set to zero. Here IC 311 is used as a zero crossing detector.

### **CONTROLLER:**

The controller operates on +5 V dc, so the regulated +v 5 v is supplied to pin no. 40 and ground at pin no. 20. The controller is used here need not required to handle high frequency signals, so as 4 MHz crystal is used for operating the

processor. The pin no. 9 is supplied with a +5V dc through a push switch. To reset the processor .As prepare codes are store in the internal flash memory the pin no. 31 is connected to + Vcc.

#### PORT ASSIGNMENT:

Port 1:-Input to LCD.

Port 2:- Input to relay driver

Port3.0 & Port3.1:- Input port from the function generator.

P1.6 is used as input port increment

P1.7 is used as on input port decrement

#### RELAY:

The relay driver is L293D.The relay used here having the specification as follows,

Coil resistance =400ohm

Coil voltage=12Vdc

Contact capacity=230V, 7A

### **Analysis**

#### ALGORITHM:

##### **(a)Altering phase of two signals**

Step-1:- Timer0 set and run till Timer1 is set or vice-versa.

Step-2:- Two signals (current & voltage) are introduced.

Step-3:- Phase angle between the two signals altered by incrementing or decrementing delay between two.

Step-4:- Delay of 0.1 ms is given while incrementing or decrementing.

Step-5:- Accumulator stores the number of incrementing or decrementing operations.

Step-6:- Delay is called according to the number stored in the accumulator.

Step-7:- The signals, altered in phase are sent to the motherboard for power factor detection.

##### **(b) Phase angle Detection:**

Step-1:- Microcontroller started on interrupt mode.

Step-2:-INTX0 & INTX1 are enabled.

Step-3:-INTX0 given VOLTAGE (V), INTX1 given CURRENT (I) from sampling circuit.

Step-4:-Timer measures time interval between two interrupts.

Step-5:-Time interval calibrated as  $0-5\text{ms} = 0-90$  degree.

Step-6:-Calibrated data is converted from HEX to BCD, then to ASCII for display on LCD.

### **Results**

This method of improving the power factor gives rise to the correction of power factor of inductive load.

### **Conclusions**

It can be concluded that power factor correction techniques can be applied to the industries, power systems and also house holds to make them stable and due to that the system becomes stable and efficiency of the system as well as the apparatus increases. The use of microcontroller reduces the costs. Due to use of microcontroller multiple parameters can be controlled and the use of extra hard wares such as timer,RAM,ROM and input output ports reduces. Care should be taken for overcorrection otherwise the voltage and current becomes more due to which the power system or machine becomes unstable and the life of capacitor banks reduces.

### **References**

- P. N. Enjeti and R martinez, "A high performance single phase rectifier with input power factor correction ,"IEEE Trans. Power Electron..vol.11,No.2,Mar.2003,pp 311-317
- J.G. Cho,J.W. Won,H.S. Lee , "Reduced conduction loss zero-voltage-transition power factor correction converter with low cost,"IEEE Trans.Industrial Electron..vol.45,no 3,Jun. 2000,pp395-400
- "The 8051 Microcontroller and Embedded Systems" by Muhammad Ali Mazidi and Janice Gillispie Mazidi

\*\*\*\*\*



