

# ***DATA ACQUISITION USING PCL-207 CARD***

***SUBMITTED BY:-  
SOUMYA RANJAN NAYAK (10607003)  
SAGAR KUMAR JENA (10607014)***

***UNDER GUIDANCE OF:-  
Prof. U.C.PATI***



**DEPARTMENT OF ELECTRONICS AND COMMUNICATION  
ENGG.  
NATIONAL INSTITUTE OF TECHNOLOGY  
ROURKELA-769008**



Electronics & Communication Department  
National Institute of Technology, Rourkela

---

## CERTIFICATE

---

This is to certify that the thesis entitled, “**Data acquisition using PCL-207 card**” submitted by **Soumya Ranjan Nayak** and **Sagar Kumar Jena** in partial fulfillment of the requirements for the award of Bachelor of Technology Degree in Electronics & Communication Department at the National Institute of Technology, Rourkela (Deemed University) is an authentic work carried out by them under my supervision.

**Prof. Umesh Chandra Pati**

Electronics & Communications Engineering

National Institute of Technology, Rourkela  
India

Date:  
N.I.T Rourkela

# Acknowledgements

---

My first and foremost regards for Prof. U.C.Pati, without whose constant supervision and guidance this project would never have been a reality. He has been a guide par excellence whose academic mentorship and unflinching moral support kept us motivated and driven, even at the most difficult times when giving up seemed the best choice. The confidence and faith he reposed on us has indeed been instrumental in improving ourselves at each and every step of the project and has made it a significant learning experience. We are indebted to Prof. U.C.Pati for all his invaluable aegis.

It wouldn't have been ever possible to accomplish a project of this scale without the references and ideas taken from others. They also deserve due credit and veneration.

We also profoundly thank the Almighty, without whose grace this project would have been a distant dream, and for making this journey such a wonderful experience.

Soumya Ranjan Nayak

Sagar Kumar Jena

Dept. of Electronics & Communication Engineering

National Institute of Technology, Rourkela

## **ABSTRACT**

The field of data acquisition and control encompasses a very wide range of activities. At its simplest level, it involves reading electrical signals into a computer from some form of sensor. These signals may represent the state of a physical process, such as the position and orientation of machine tools, the temperature of a furnace or the size and shape of a manufactured component. The acquired data may have to be stored, printed or displayed. Often the data have to be analyzed or processed in some way in order to generate further signals for controlling external equipment or for interfacing to other computers. This may involve manipulating only static readings, but it is also frequently necessary to deal with time-varying signals as well.

In less than a decade, the PC has become the most widely used platform for data acquisition and control. The main reasons for the popularity of PC-based technology are low costs, flexibility and ease of use, and, last but not the least, performance. Data acquisition with a PC enables one to display, log and control a wide variety of real world signals such as pressure, flow, and temperature. This ability coupled with that of easy interface with various stand-alone instruments makes the systems ever more desirable.

Until the advent of the PC, data acquisition and process monitoring were carried out by using dedicated data loggers, programmable logic controllers and or expensive proprietary computers.

In this project we have used the thermocouple(J-type) to acquire the temperature of water being heated by a heater , which we have got in mili volts range. This has been further converted approximately into the range of 5 volt by using an amplifier of suitable gain (1000). We have used the data acquisition card PCL-207 to interface the amplified output to PC.

## ***CONTENT:***

SL.NO:-	TOPIC	PAGE NO:-
1	INTRODUCTION	6-11
2	TRANSDUCER	12-17
3	SIGNAL CONDITIONING	18-20
4	DATA ACQUISITION CARD PCL-207	21-24
5	PCL-207 PROGRAMMING	25-33
6	DATA ACQUISITION USING MICRO-CONTROLLER	34-45
7	CONCLUSION	47
8	REFERENCE	48

# ***1. INTRODUCTION***

# ***DEFINITION OF DATA ACQUISITION AND CONTROL:***

Data acquisition is the process by which physical quantities from the real world are transformed into electrical signals that are measured and converted into a digital format for processing, analysis, and storage by a computer.

In majority of applications, the data acquisition (DAQ) system is designed not only to acquire data, but to control it as well. In defining DAQ systems, it is therefore useful to extend this definition to include the control aspects of the total system. Control is the process by which digital control signals from the system hardware are converted to a signal format for use by control devices such as actuators and relays. These devices then control a system or process.

## ***FUNDAMENTALS OF DATA ACQUISITION:***

A data acquisition and control system, built around the power and flexibility of the PC, may consist of diverse hardware building blocks from different equipment manufacturers. It is the task of the system integrator to bring these individual components into a complete working system.

The basic elements of a data acquisition system are:

- Sensors and transducers
- Field wiring
- Signal conditioning
- Data acquisition hardware
- PC (host computer)
- Data acquisition software

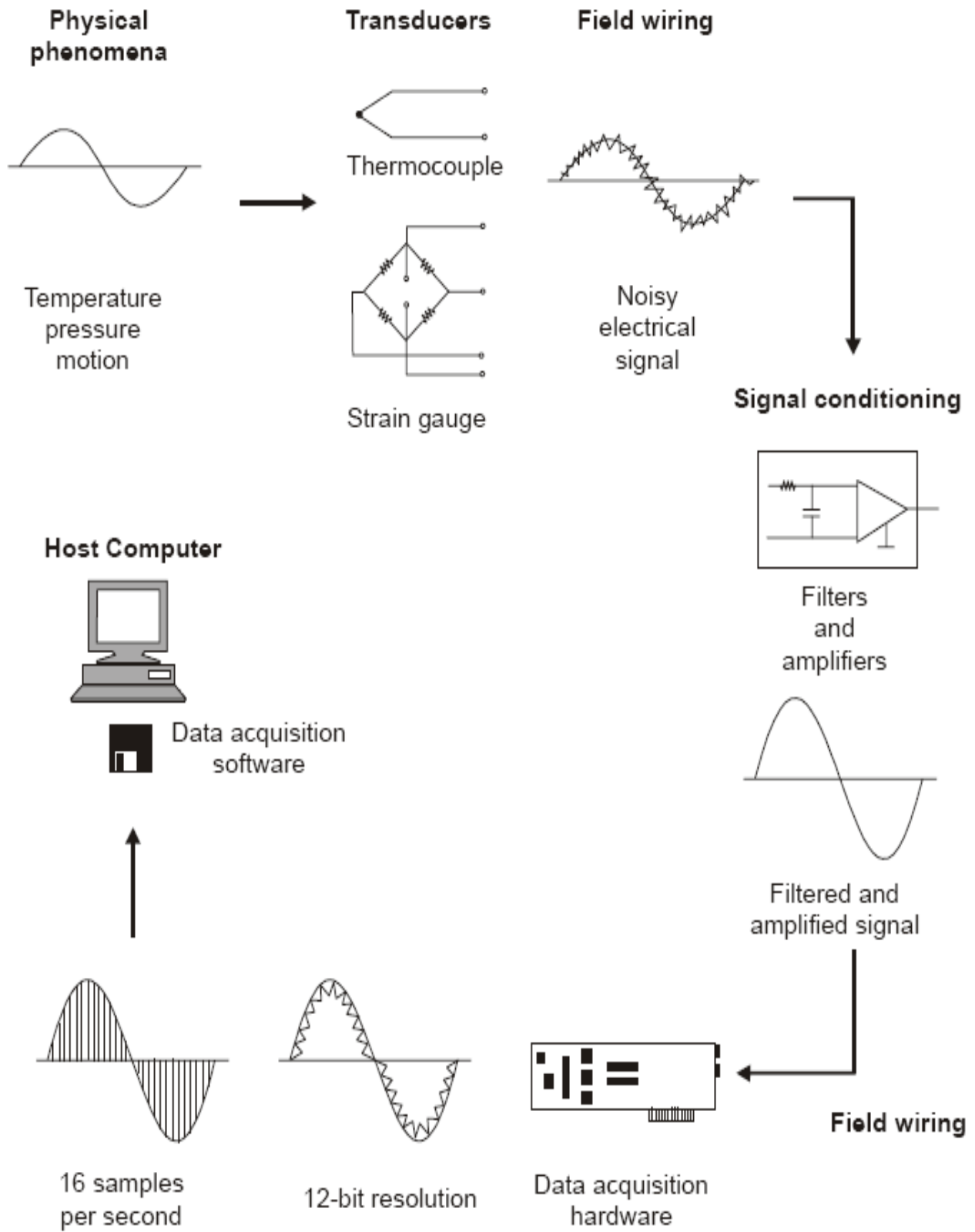

**FUNCTIONAL DIAGRAM OF PC-BASED DATA ACQUISITION SYSTEM**



## ***1. Transducers and sensors:***

Transducers and sensors provide the actual interface between the real world and the data acquisition system by converting physical phenomena into electrical signals that the signal conditioning and/or data acquisition hardware can accept.

Transducers available can perform almost any physical measurement and provide a corresponding electrical output. For example: thermocouples which convert temperature into an analog signal, while flow meters produce digital pulse trains whose frequency depends on the speed of flow.

Strain gauges and pressure transducers measure force and pressure respectively, while other types of transducers are available to measure linear and angular displacement, velocity and acceleration, light, chemical properties (e.g. pH), voltages, currents or resistances. In every case, the electrical signals produced are proportional to the physical quantity being measured according to some defined relationship.

## ***2. Field wiring and communications cabling:***

Field wiring is the physical connection from the transducers and sensors to the signal conditioning hardware and/or data acquisition hardware. When the signal conditioning and/or data acquisition hardware is located far from the PC, then the field wiring provides the physical link between these hardware elements and the host computer. If this physical link is an RS-232 communications interface, then this component of the field wiring is often referred to as communications cabling. Since field wiring and communications cabling often physically represents the largest component of the total system, it is most susceptible to the effects of external noise, especially in harsh industrial environments. The correct earthing and shielding of field wires and communications cabling is of paramount importance in reducing the effects of noise.

## ***3. Signal conditioning:***

Electrical signals generated by transducers often need to be converted to acceptable form to the data acquisition hardware, particularly the A/D converter which converts the signal data to the required digital format.

The principal tasks performed by signal conditioning are:

- Filtering
- Amplification
- Linearization
- Isolation
- Excitation

## ***Filtering***

In noisy environments, it is very difficult for very small signals received from sensors such as thermocouples and strain gauges (in the order of mV), to survive without the sensor data being compromised. Where the noise is of the same or greater order of magnitude than the required signal, the noise must first be filtered out. Signal conditioning equipment often requires low pass filters to eliminate high frequency noise that can lead to undesirable data.

## ***Amplification***

Having filtered the required input signal, it must be amplified to increase the resolution. The maximum resolution is obtained by amplifying the input signal so that the maximum voltage swing of the input signal equals the input range of the analog-to-digital converter (ADC), contained within the data acquisition hardware. The amplifier should be placed as close to the sensor as physically possible to reduce the effects of noise on the signal lines between the transducer and the data acquisition hardware.

## ***Linearization***

Many transducers, such as thermocouples, display a non-linear relationship to the physical quantity they are required to measure. The method of linearizing these input signals varies for various signal conditioning products. For example, in the case of thermocouples, some products match the signal conditioning hardware to the type of thermocouple, providing hardware to amplify and linearize the signal at the same time. A cheaper, easier, and more flexible method is provided by signal conditioning products that perform the linearization of the input signal using software.

## ***Isolation***

Signal conditioning equipment can also be used to provide isolation of transducer signals from the computer where there is a possibility that high voltage transients may occur within the system being monitored, either due to electrostatic discharge or electrical failure. Isolation protects expensive computer equipment from damage and computer operators from detrimental effect.

## ***Excitation***

Signal conditioning products also provide excitation for some transducers. For example: strain gauges, thermistors and RTDs, require external voltage or current excitation signals.

## ***4.Data acquisition hardware:***

Data acquisition and control (DAQ) hardware can be defined as that component of a complete data acquisition and control system, which performs any of the following functions:

- The input, processing and conversion to digital format, using ADCs, of analog signal data measured from a system or process – the data is then transferred to a computer for display, storage and analysis.
- The input of digital signals, which contain information from a system or process.
- The processing, conversion to analog format, using DACs, of digital signals from the computer – the analog control signals are used for controlling a system or process.
- The output of digital control signals.

## ***5.Data acquisition software:***

Data acquisition hardware does not work without software, because it is the software running on the computer that transforms the system into a complete data acquisition, analysis, display, and control system.

## ***6.Host computer:***

The PC used in a data acquisition system can greatly affect the speeds at which data can be continuously and accurately acquired, processed, and stored for a particular application. Applications requiring real-time processing of high-frequency signals need a high-speed, 32-bit processor with its accompanying coprocessor, or a dedicated plug-in processor such as a digital signal processing (DSP) board. If the application only acquires and scales a reading once or twice a second, however, a low-end PC can be satisfactory.

Depending on the particular application, the microprocessor speed, hard disk access time, disk capacity and the types of data transfer available, can all have an impact on the speed at which the computer is able to continuously acquire data.

## ***2. Transducer***

Most real-world events and their measurements are analog. That is, the measurements can take on a wide, nearly continuous range of values. The physical quantities of interest can be as diverse as heat, pressure, light, force, velocity, or position. To be measured using an electronic data acquisition system, these quantities must first be converted to electrical quantities such as voltage, current, or impedance.

A transducer converts one physical quantity into another. The characteristics that are most important in determining a transducer's applicability for a given application are as follows:

- Accuracy
- Sensitivity
- Repeatability
- Range

## ***Accuracy***

The accuracy of a transducer describes how close a measurement is to the actual value of the process variable being measured. It describes the maximum error that can be expected from a measurement taken at any point within the operating range of the transducer. Accuracy of a transducer is usually provided as a percentage error over the operating range of the transducer, such as  $\pm 1\%$  between  $20^{\circ}\text{C}$  and  $120^{\circ}\text{C}$ , or as a rating (i.e.  $\pm 1^{\circ}\text{C}$ ) over the operating range of the transducer.

## ***Sensitivity***

Sensitivity is defined as the amount of change in the output signal from a transducer to a specified change in the input variable being measured. Highly sensitive devices, such as thermistors, may change resistance by as much as 5% per  $^{\circ}\text{C}$ , while devices with low sensitivity, such as thermocouples, may produce an output voltage that changes by only  $5\mu\text{V}$  per  $^{\circ}\text{C}$ .

## ***Repeatability***

If two or more measurements are made of a process variable at the identical state, a transducer's repeatability indicates how close the repeated measurements will be. The ability to generate almost identical output responses to the same physical input throughout its working life is an indication of the transducer's reliability.

## ***Range***

A transducer is usually constructed to operate within a specified range. The range is defined as the minimum and maximum measurable values of a process variable between which the defined limits of all other specified transducer characteristics (i.e. sensitivity, accuracy etc) are met. A thermocouple, for example, could well work outside its specified operating range of 0°C to 500°C, however its sensitivity outside this range may be too small to produce accurate or repeatable measurements.

Several variables affect the accuracy, sensitivity, and repeatability of the measurements being made. In the process of measuring a physical quantity, the transducer disturbs the system being monitored. As an example, a temperature measuring transducer lowers the temperature of the system being monitored, while energy is used to heat its own mass. Transducers are responsive to unwanted noise in the same way that a record player's magnetic cartridge is sensitive to the alternating magnetic field of the mains transformer.

## ***THERMOCOUPLE:***

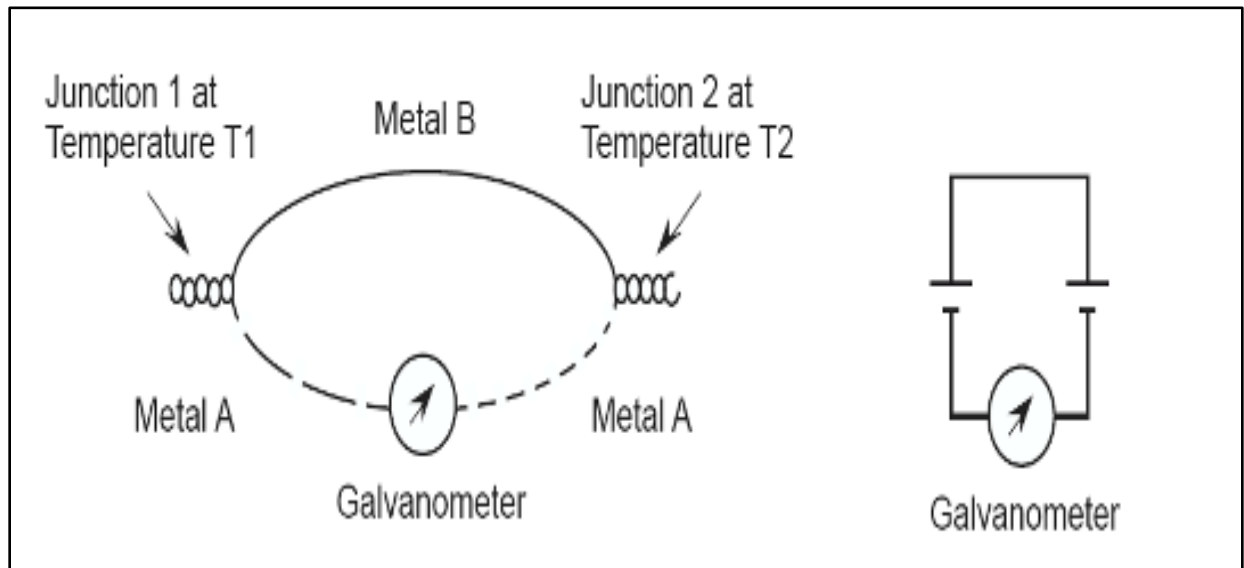

- A thermocouple consists of two pieces of dissimilar metals with their ends joined together (by twisting, soldering or welding). When heat is applied to the junction, a voltage, in the range of milli-volts (mV), is generated.
- The output voltage varies linearly with the temperature difference between the junctions— higher the temperature difference, higher is the voltage output. This linearity is a chief advantage of using a thermocouple, as well as its ruggedness as a sensor. In addition, thermocouples operate over very large temperature ranges and at very high temperatures (some, over 1000°C).
- The five standard base-metal thermocouples are chromel–constantan (type E), iron–constantan (type J), chromel–alumel (type K), nicrosil–nasil (type N) and copper–constantan (type T).
- In this project type J thermocouple has been used . Iron–constantan thermocouples have a sensitivity of  $60 \mu\text{V}/^\circ\text{C}$  and are the preferred type for general-purpose measurements in the temperature range  $-150^\circ\text{C}$  to  $1000^\circ\text{C}$ , where the typical measurement inaccuracy is 0.75%.

## Thermocouple reading:

Temperature(C)	Output voltage (mV)		Mean(mV)
	increasing	decreasing	
35	0.2	0.3	0.25
40	0.4	0.6	0.5
45	0.7	0.8	0.75
50	0.9	1.1	1.0
55	1.2	1.4	1.3
60	1.5	1.7	1.6
65	1.8	1.8	1.8
70	2.1	2.0	2.05
75	2.3	2.2	2.25
80	2.6	2.4	2.5
85	2.9	2.7	2.8
90	3.1	3.3	3.2
95	3.4	3.5	3.45
100	3.7	3.7	3.7



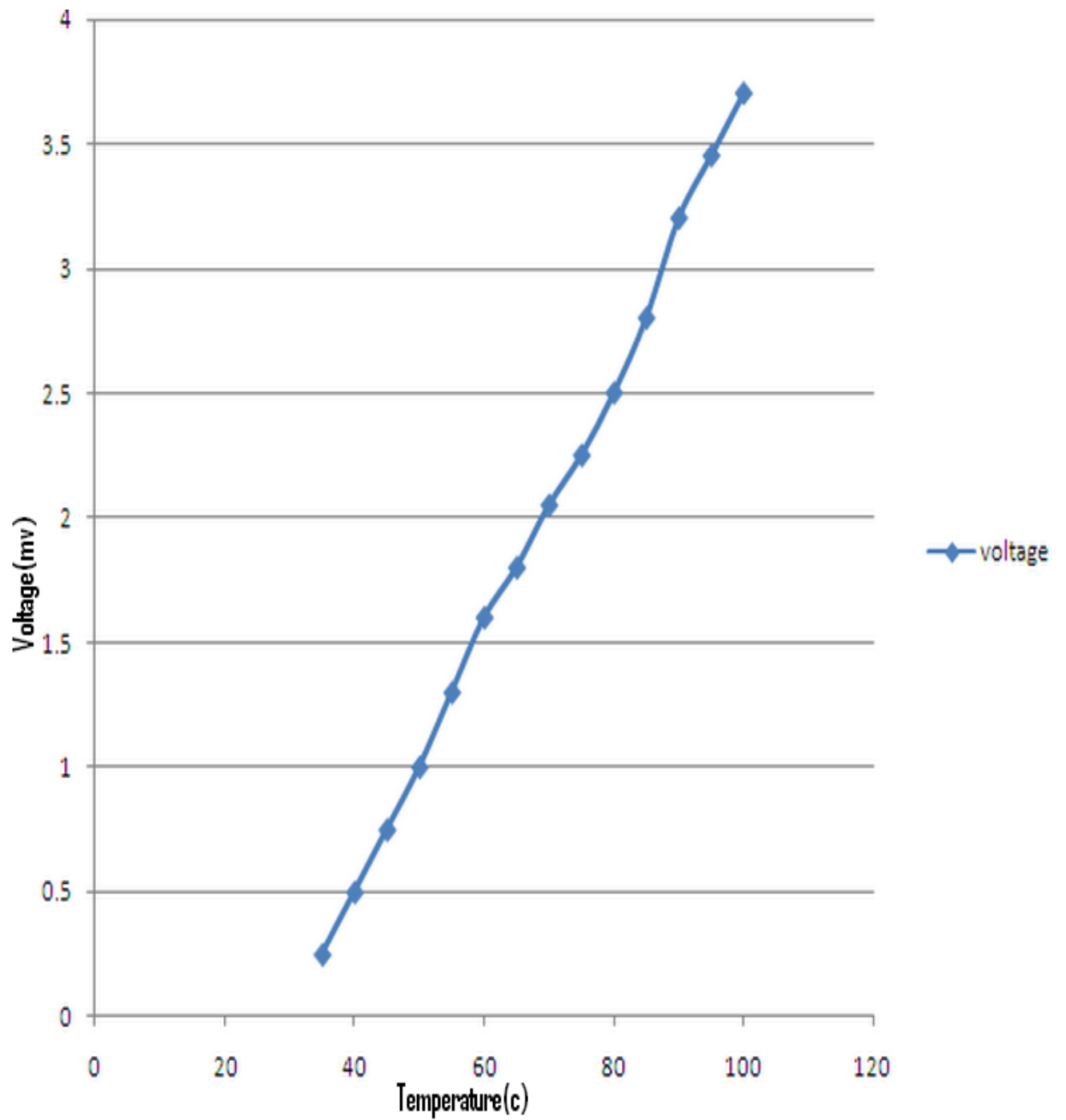

*Temperature vs o/p voltage graph*

# ***3.SIGNAL CONDITIONING***

## ***SIGNAL CONDITIONING:***

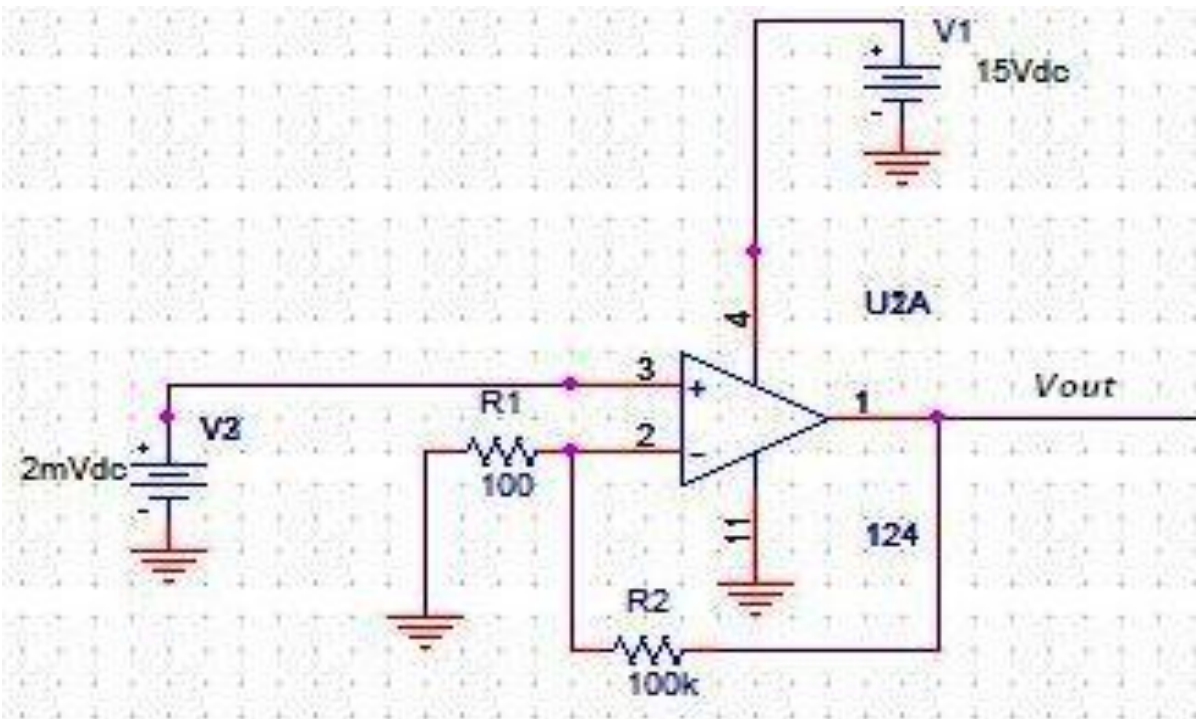

- Electrical signals generated by transducers often need to be converted to a form acceptable to the data acquisition hardware, particularly the A/D converter which converts the signal data to the required digital format.
- Here our thermocouple output is ranging from 0-4mv .So it is not suitable for signal processing . That is why it needs signal conditioning . Our A/D converter works well within range of 0-5v as we are providing input as +/-5v.Here we used OP-AMP 741 IC in suitable configuration to produce a gain of approx. 1000.

- Calculation of Amplifier Gain:

R1=100

R2=100k

GAIN =1+ (R2 /R1)

= 1+(100k /100)

= 1001

**TABLE FOR AMPLIFIER:**

SL.No	Temperature(C)	Thermocouple Output(mV)	Amplifier Output(V)
1	35	0.25	0.24
2	40	0.5	0.50
3	45	0.75	0.73
4	50	1.0	0.97
5	55	1.3	1.30
6	60	1.5	1.48
7	65	1.8	1.76
8	70	2.05	2.02
9	75	2.25	2.23
10	80	2.5	2.47
11	85	2.8	2.80
12	90	3.2	3.19
13	95	3.45	3.44
14	100	3.7	3.62

# ***4. DATA ACQUISITION***

## ***CARD PCL-207***

## ***SPECIFICATIONS:***

The data acquisition card has following specification:

### ***1. Analog Input (A/D converter)***

Channels : 8 single ended  
Resolution : 12 bits  
Input Range : Bipolar +/- 5v  
Overvoltage : continuous +/- 30v max.  
Conversion type : Successive approximation type  
Converter : AD574 or equivalent  
Conversion speed: 25 microsecond max.  
Accuracy : 0.015% of reading +/- 1 bit  
Linearity : +/- 1bit  
Trigger mode : Software trigger  
Data transfer : Program control

### ***2. Analog Output (D/A converter)***

Channels : 1 channel  
Resolution : 12 bits  
Output range : 0 to +5 v or 0 to +10v  
Reference voltage: Internal -5v and -10v(+/-0.05v)  
Conversion type : 12 bit monolithic multi-typing  
Analog devices : AD7541 AKN or equivalent  
Linearity : +/- ½ bit  
Output drive : +/- 5 ma max  
Settling time : 30 micro seconds

### ***3. General Specifications***

Power consumption: +5V: typ 100 ma, max 500ma  
+12V:typ 40 ma, max100 ma  
-12V:typ 20 ma, max 50ma  
I/O connector : 20 pin post headers for analog I/O ports

## ***Hardware Details:***

### ***Base Address Selection:***

An 8 way DIP switch is present on board out of which SW1-SW6 is used for base address selection and SW7 and SW8 are used for software trigger selection.

The PCL-207 requires 16 consecutive address location in the I/O space. Valid addresses are from hex 000 to hex 3F0. The factory setting is hex 220. If the user wants to change the default value to another value then before installing the card in the computer he must change the switch setting to any of the following addresses.

<b>I/O Address</b>	<b>Switch selection</b>					
<b>Range(Hex)</b>	<b>1</b>	<b>2</b>	<b>3</b>	<b>4</b>	<b>5</b>	<b>6</b>
	<b>A9</b>	<b>A8</b>	<b>A7</b>	<b>A6</b>	<b>A5</b>	<b>A4</b>
000-00F	0	0	0	0	0	0
100-10F	0	1	0	0	0	0
200-20F	1	0	0	0	0	0
210-21F	1	0	0	0	0	1
220-22F	1	0	0	0	1	0
300-30F	1	1	0	0	0	0
3F0-3FF	1	1	1	1	1	1

***NOTE: ON-0 , OFF-1***

A4-A9 corresponds to PC bus address lines.

## ***CONNECTOR PIN ASSIGNMENT***

PCL-207 I provided with a single 20 pin FRC connector CN1, accessible through the rear of the PC. The pin assignment of this connector is as given below.

<b>SIGNAL NAME</b>	<b>PIN NO.</b>	<b>PIN NO.</b>	<b>SIGNAL NAME</b>
A/D 0	1	2	A.GND
A/D 1	3	4	A.GND
A/D 2	5	6	A.GND
A/D 3	7	8	A.GND
A/D 4	9	10	A.GND
A/D 5	11	12	A.GND
A/D 6	13	14	A.GND
A/D 7	15	16	A.GND
D/A	17	18	A.GND
A.GND	19	20	A.GND

## **JUMPER SELECTION**

Only one jumper JP1 is provided on the PCL-207 card. It is used to select the D/A reference voltage. Two reference voltage are present on the board.



# ***5. PCL-207 PROGRAMMING***

## ***SOFTWARE INSTALLATION:***

A floppy disk containing a comprehensive I/O driver routine for A/D-D/A applications is included with each PCL-207 card. It is written in assembly language and can be accessed through a CALL statement in BASICA or Quick BASIC. The PCL-207 I/O is written in assembly language and compiled into a program 207BAS.BIN .

## ***LOADING DRIVER:***

I/O driver is loaded to a memory segment which is independent from the BASIC work area.

The steps involved are:

- a. Locate a memory segment with at least 2K bytes free at its beginning.
- b. Load the binary program 207BAS.BIN with the BLOAD command from the beginning of the memory segment.

```
110 'LOAD 207BAS.BIN DRIVER TO OUTSIDE AREA
```

```
120 DEF SEG=&H5000      'DEFINE OUTSIDE AREA
```

```
130 BLOAD "207BAS.BIN",0
```

```
140 'END OF DRIVER LOADING
```

After the driver has been loaded ,it should be linked by a DEF command immediately before each driver FUNCTION is called in basic or by the 'extern' keyword for usage in C language.

## ***PCL-207 DRIVER ROUTINES:***

There are eight PCL-207 driver functions. Each function covers an important area of the use of PCL-207. The following is the list of all the functions:

<b>FUNCTION</b>	<b>DESCRIPTION</b>
FUNCTION 0	Initialize the PCL-207 driver routines by specifying the base address.
FUNCTION 1	Set the multiplexer scan range.
FUNCTION 2	Reserved
FUNCTION 3	Perform a software triggered single A/D conversion.
FUNCTION 4	Perform software trigger initiated N A/D conversions.
FUNCTION 5 to FUNCTION 14	Reserved
FUNCTION 15	Write data to D/A channel.
FUNCTION 16 to FUNCTION 20	Reserved

## ***FORMAT FOR THE FUNCTIONS:***

### **BASIC:**

CALL PCL207(FUNC%,DAT%(0), ERR%)

### ***LEGEND:***

PCL207 : A variable specifying the memory offset of the starting address of the PCL-207 driver routine from the most recently defined current segment.

FUNC%: A variable indicating the driver function to be executed.

DAT%(0): A variable specifying the starting location of the entire data array.

ERR%: A variable containing the return message code.

### **C PROGRAMMING:**

```
er = pcl207 (fun, &dat[0], &ary1[0], &ary2[0]);
```

### ***LEGEND:***

er = return message code.

fun = driver function to be executed.

&dat[0] = data array

&ary1[0] = array pointer at which the converted data can be stored.

&ary2[0] = array pointer at which the corresponding channel number of each conversion can be stored.

## ***FUNCTION 0: Initialization***

### ***Purpose:***

This function initializes the PCL-207 base address. This function must be performed before any other functions and the only one initialization is necessary in each operation session.

### **PARAMETER:**

FUNC%- Function. The value is 0.

DAT%(0)- Entry: I/O address. The default value is Hex 220.

ERR%-Return message.

## ***FUNCTION 1: Set Mux Scan Range:***

### ***Purpose:***

This function sets the multiplexer scan range. If the current scan range does not meet the next A/D conversion range requirements, this function must be performed prior to calling any A/D conversion function. i.e. FUNCTION 3 and 4.

### **PARAMETER:**

FUNC%- Function. The value is 1.

DAT%(0)- Entry: Start scan channel. Valid values are from 0 to 7.

DAT%(1)- Entry: Stop scan channel. Valid values are from 0 to 7.

ERR%- Return message.

### ***FUNCTION 3 –Perform single A/D conversion:***

#### ***Purpose:***

This function performs a software triggered single A/D conversion.

#### **PARAMETER:**

FUNC%- Function. The value is 3

DAT%(0)- Entry :not significant

Return: converted A/D data

DAT%(1)- Entry :not significant

Return: channel number of data derived from

DAT%(2)- Entry :not significant

Return: next channel number

ERR% - return message

### ***FUNCTION 4 –Perform N, A/D conversion:***

#### ***Purpose:***

This function performs software trigger initiated N, A/D conversions.

#### **PARAMETER:**

FUNC%- Function. The value is 4

DAT%(0)- Entry: number of conversions required.

DAT%(1)- Entry: array pointer at which converted data can be stored.

DAT%(2)- Entry: delay time between samples

DAT%(3)- Entry: array pointer at which the corresponding channel number of each conversion can be stored.

ERR%- return message

### ***FUNCTION 15 – Set D/A Output:***

#### ***Purpose:***

The function writes data to the D/A channel.

#### **PARAMETER:**

FUNC% - Function. The value is 15.

DAT%(0) – Entry: D/A channel number.

DAT%(1)- Entry: D/A data.

ERR% - return message

## ADC USING PCL207

Procedure for connection:-

- 1) Connect the PCL card to any of the ISA slot .Before connecting check the switch setting it base address should be set to 220.
- 2) Give the input voltage to **channel 1** as 0 to 5 volt.
- 3) Compile and run the program using Turbo C and the result on the console screen as the voltage is varied.

### C CODE:

```
#include<stdio.h>

main()

{   int ch,ba=0x220,hb,lb,e;

    float volts,count;

    clrscr();

up:

    ch=0;        //ch1=start channel no.
    outp(ba+10,ch); //mux scan channel
    outp(ba+12,0); //software ad trigger
    chk:
    e=inp(ba+5);
    if(e>=16)    //check for DRDY low
    goto chk;
    else
    hb=(e & 15);
    lb=inp(ba+4);
    count=(hb*256+lb)-2048;
    volts=(count*10)/4096;
    printf("\n  CHANNEL %d  VOLTS %10.4f COUNT %10.0f\n " ch,volts,count);
    goto up;

}
```



## ***CALIBRATION:***

To maintain the accuracy of the data acquisition calibration has to be done.

## ***PCL 207 VR ASSIGNMENT:***

There are three variable resistors (VR) on the PCL-207 to assist making accurate adjustment

On the A/D and D/A channels. The function of each VR is listed below:

VR1: D/A gain adjustment

VR2: A/D offset adjustment

VR3: A/D gain adjustment

## ***A/D CALIBRATION:***

1. Apply a short to the input channel and adjust VR2(offset)to obtain zero data.
2. Apply +4.9963V to the input channel and adjust VR(gain) so that the data lies between 2046 and 2047.

# ***6. DATA ACQUISITION USING MICROCONTROLLER***

# MICROCONTROLLER-8051

## Features (AT89c51):

- Compatible with MCS-51™ Products
- 4K Bytes of In-System Reprogrammable Flash Memory
  - Endurance: 1,000 Write/Erase Cycles
- Fully Static Operation: 0 Hz to 24 MHz
- Three-level Program Memory Lock
- 128 x 8-bit Internal RAM
- 32 Programmable I/O Lines
- Two 16-bit Timer/Counters
- Six Interrupt Sources
- Programmable Serial Channel
- Low-power Idle and Power-down Modes

## 8051 PIN DIAGRAM:

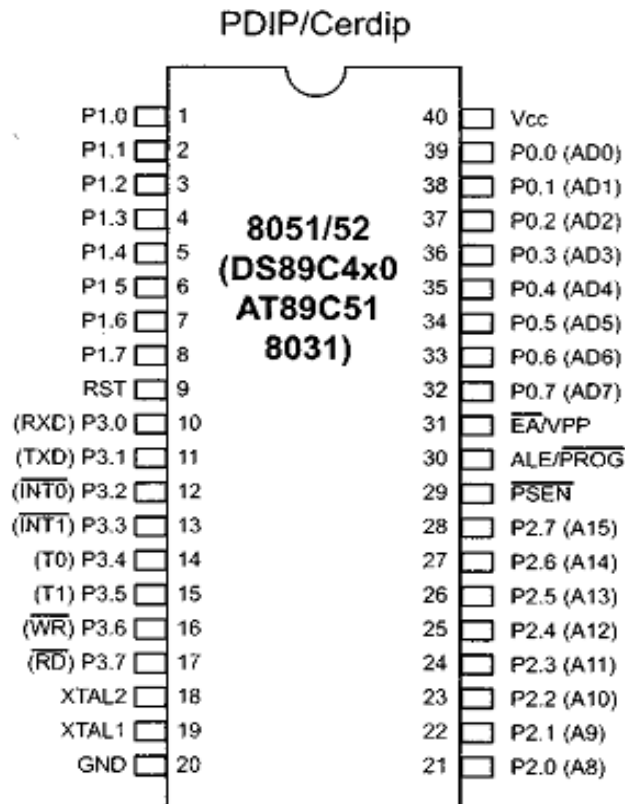

## ***PIN DESCRIPTION:***

### **VCC**

Supply voltage.

### **GND**

Ground.

### **ALE/PROG**

Address Latch Enable output pulse for latching the low byte of the address during accesses to external memory. This pin is also the program pulse input (PROG) during Flash programming.

### **PSEN**

Program Store Enable is the read strobe to external program memory.

When the AT89C51 is executing code from external program memory, PSEN is activated twice each machine cycle, except that two PSEN activations are skipped during each access to external data memory.

### **EA/VPP**

External Access Enable. EA must be strapped to GND in order to enable the device to fetch code from external program memory locations starting at 0000H up to FFFFH. Note, however, that if lock bit 1 is programmed, EA will be internally latched on reset. EA should be strapped to VCC for internal program executions. This pin also receives the 12-volt programming enable voltage (VPP) during Flash programming, for parts that require 12-volt VPP.

### **XTAL1**

Input to the inverting oscillator amplifier and input to the internal clock operating circuit.

### **XTAL2**

Output from the inverting oscillator amplifier..

### **RST**

Reset input. A high on this pin for two machine cycles while the oscillator is running resets the device.

<b>Port Pin</b>	<b>Alternate Functions</b>
P3.0	RXD (serial input port)
P3.1	TXD (serial output port)
P3.2	$\overline{\text{INT0}}$ (external interrupt 0)
P3.3	$\overline{\text{INT1}}$ (external interrupt 1)
P3.4	T0 (timer 0 external input)
P3.5	T1 (timer 1 external input)
P3.6	$\overline{\text{WR}}$ (external data memory write strobe)
P3.7	$\overline{\text{RD}}$ (external data memory read strobe)

# ADC 0804:

## Features

- 80C48 and 80C80/85 Bus Compatible - No Interfacing Logic Required
- Conversion Time . . . . . <100 $\mu$ s
- Easy Interface to Most Microprocessors
- Will Operate in a “Stand Alone” Mode
- Differential Analog Voltage Inputs
- Works with Bandgap Voltage References
- TTL Compatible Inputs and Outputs
- On-Chip Clock Generator
- Analog Voltage Input Range  
(Single + 5V Supply) . . . . . 0V to 5V
- No Zero-Adjust Required
- 80C48 and 80C80/85 Bus Compatible - No Interfacing Logic Required

### Pinout

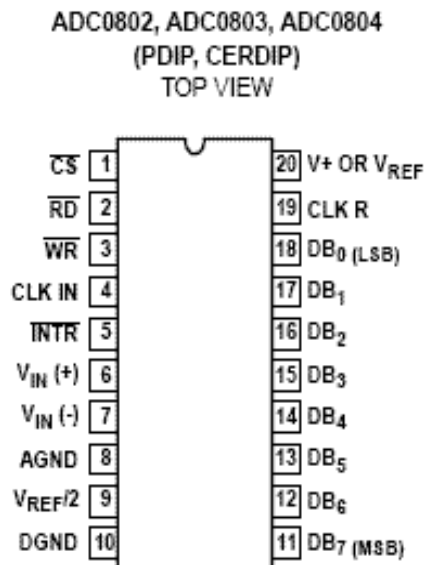

### Typical Application Schematic

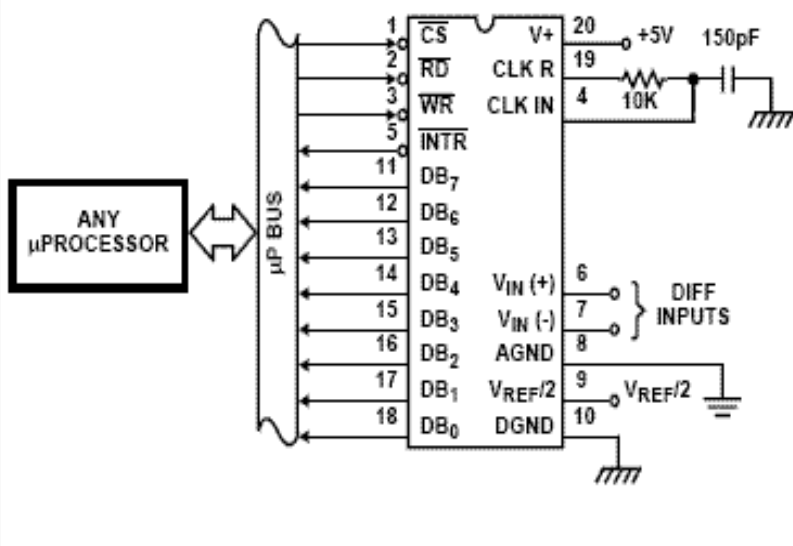

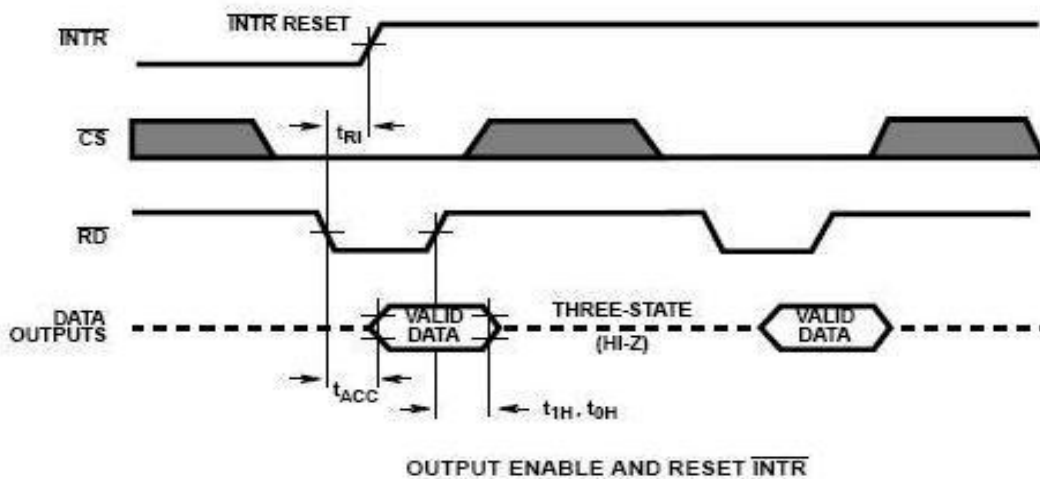
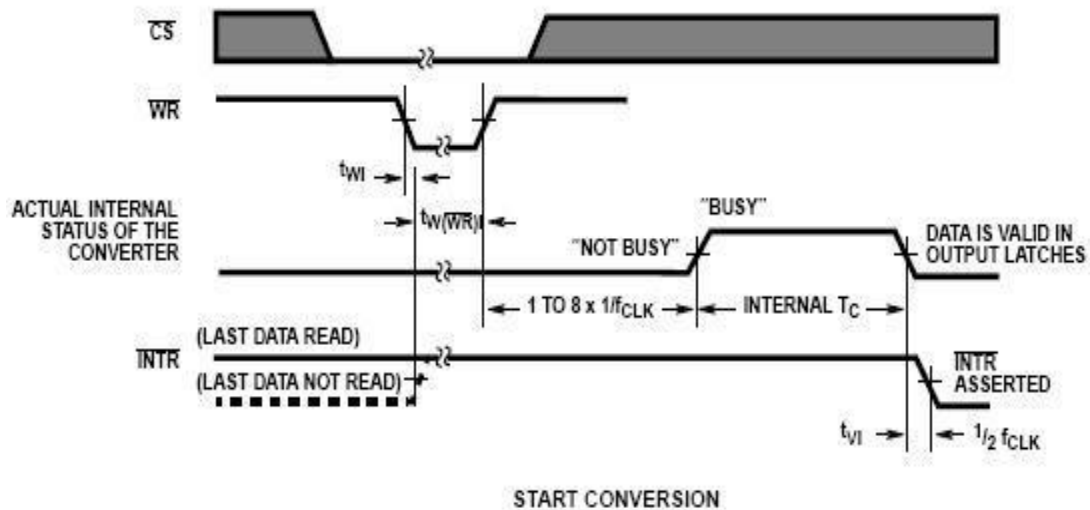

The above timing diagrams are from ADC0804 datasheet. The first diagram shows how to start a conversion. We can see which signals are to be asserted and at what time to start a conversion. So looking into the timing diagram we note down the steps or the order in which signals are to be asserted to start a conversion of ADC. Below steps are for starting an ADC conversion

1. Make chip select (CS) signal low.
2. Make write (WR) signal low.
3. Make chip select (CS) high.
4. Wait for INTR pin to go low (means conversion ends).

Once the conversion in ADC is done, the data is available in the output latch of the ADC. Data of the new conversion is only available for reading after ADC0804 made INTR pin low or say when the conversion is over. Below are the steps to read output from the ADC0804.

1. Make chip select (CS) pin low.
2. Make read (RD) signal low.
3. Read the data from port where ADC is connected.
4. Make read (RD) signal high.
5. Make chip select (CS) pin high.

## DATA ACQUISITION CIRCUIT:

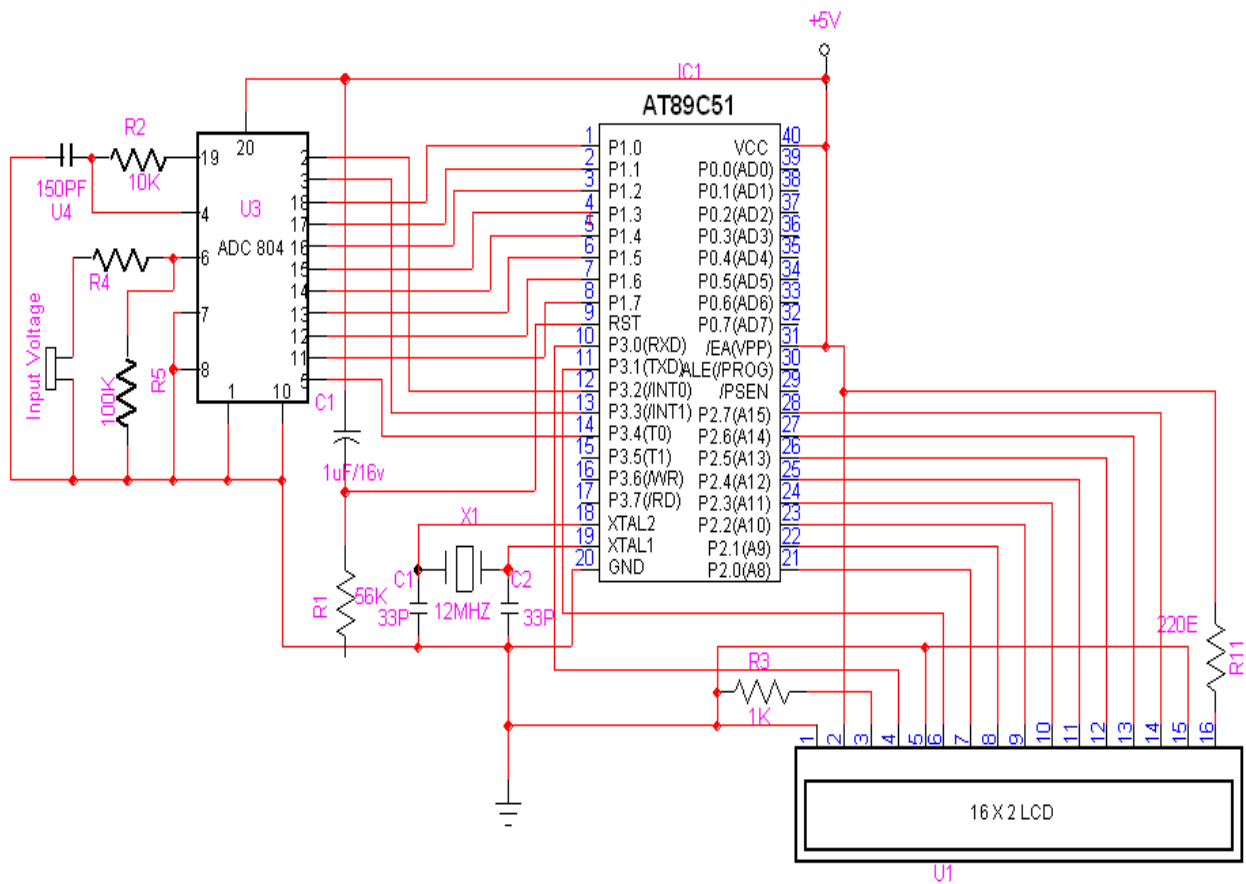



## ***DESCRIPTION:***

The objective of an A/D converter is to determine the output digital word corresponding to an analog input signal. The A/D converter operates on the principle of successive approximation. Analog switches are closed sequentially by successive-approximation logic until the analog differential input voltage [ $V_{in(+)} - V_{in(-)}$ ] is matched to a voltage derived from a tapped resistor string across the reference voltage.

During the normal operation, on the high-to-low transition of the WR input, the internal SAR latches and the shift-register stages are reset, and the INTR output will be set to high. As long as the CS input and WR input remain low, the A/D will remain in a reset state. Conversion will start from 1 to 8 clock periods after at least one of these inputs makes low-to-high transition. After the completion of conversion, the INTR pin will make a high-to-low transition. This can be used to interrupt a processor, or otherwise signal the availability of a new conversion. A RD operation (with CS low) will clear the INTR line high again. The device may be operated in the free-running mode by connecting INTR to the WR input with CS=0.

Since this is an 8-bit A/D converter; for a voltage input from 0-5V, 0 will be represented as 0000 0000 (0 in decimal) and 5V is represented as 1111 1111 (256 in decimal). To convert a value X volts to decimal, we use the following formula:  $(X * 5.0)/256$ .

## ***PROGRAM:***

```
ORG 0

RD BIT P2.5                ;RD

WR BIT P2.6                ;WR(start conversion)

INTR BIT P2.7              ;end of conversion

MYDATA EQU P1              ;P1.0-P1.7=D0-D7 of the ADC0804

MOV P1, #0FFH              ;make P1= input

SETB INTR

BACK:

    CLR WR                  ;WR=0

    SETB WR                 ;WR=1 L-to-H to start conversion

HERE:

    JB INTR,HERE            ;wait for end of conversion

    CLR RD                  ;conversion finished enable RD

    MOV A,MYDATA            ;read the data

    ACALL CONVERSION        ;hex to ASCII conversion

    ACALL DATA_DISPLAY     ;display the data

    SETB RD                 ;make RD = 1 for next round

    SJMP BACK
```

CONVERSION:

```
RAM_ADDR EQU 40H
ASCI_RESULT EQU 50H
COUNT EQU 3
ORG 100
ACALL BIN_DEC_CONVRT
ACALL DEC_ASCI_CONVRT
SJMP $
```

BIN\_DEC\_CONVRT:

```
MOV R0,#RAM_ADDR
MOV A,P1
MOV B,#10
DIV AB
MOV @R0,B
INC R0
MOV B,#10
DIV AB
MOV @R0,B
INC R0
MOV @R0,A
RET
```

DEC\_ASCI\_CONVRT:

```
MOV R0,#RAM_ADDR
```

MOV R1,#ASCI\_RESULT

MOV R2,#3

BACK:

MOV A,@R0

ORL A,#30H

MOV @R1,A

INC R0

INC R1

DJNZ R2,BACK

RET

DATA\_DISPLAY:

ACALL READY

MOV P1,A

STB P2.0

CLR P2.1

SETB P2.2

ACALL DELAY

CLR P2.2

RET

READY:

SETB P1.7

CLR P2.0

SETB P2.1

BACK:

CLR P2.2

ACALL DELAY

SETB P2.2

JB P1.7,BACK

RET

DELAY:

MOV R3,#50

HERE2:

MOV R4,#255

HERE:

DJNZ R4,HERE

DJNZ R3,HERE2

RET

END

**TABLE FOR LCD OUTPUT:**

SL. NO	TEMPERATURE ( C)	AMPLIFIER OUTPUT( V)	LCD O/P VALUE
1	35	0.24	12
2	40	0.50	25
3	45	0.73	37
4	50	0.97	49
5	55	1.30	66
6	60	1.48	75
7	65	1.76	90
8	70	2.02	103
9	75	2.23	114
10	80	2.47	126
11	85	2.80	143
12	90	3.19	163
13	95	3.44	175
14	100	3.62	184

## ***CONCLUSION***

The detailed study of Data Acquisition process was carried out for thermocouple using Dynalog PCL-207 12 bit high performance A/D – D/A card and Atmel AT89C51 microcontroller. The PCL-207 Card has been programmed using C language and Micro-controller has been programmed using Assembly language and the result obtained has been presented as part of the thesis.

We have used PCL-207 for PC-based data acquisition. Owing to shifting of most instrumentation system towards PC compatibility it offers greater advantage compared to 89c51 based data acquisition system. Also it is more flexible as program can be changed according to requirement repeatedly. Perhaps the most important reason for using the PC for data acquisition and control is that there is now a large and expanding pool of programmers, engineers and scientists who are familiar with the PC.

### ***Future work***

We have used both model for acquiring and processing analog input but with slight modification it can be used in control application. For e.g. on the basis of data acquired from thermocouple a feedback network can be designed to control and maintain the temperature of a system at a desired value.

## ***REFERENCES:***

1. Austerlitz Howard-Data Acquisition Techniques Using PC's. New York , Academic Press,2003.
2. James Kevin- PC Interfacing and Data Acquisition. Woburn, MA 01801-2041, Newnes,2000.
3. Park John, Mackay Steve-Practical Data Acquisition for Instrumentation and Control System. Burlington, MA 01803, Newnes,2003.
4. Data Acquisition Fundamentals-Developer Zone-National Instruments :  
<http://zone.ni.com/devzone/cda/tut/p/id/3216>
5. Data Acquisition using AT89C51 and PCL-207-Dillip Ku. Das, Sandeep Sheetal:  
<http://ethesis.nitrkl.ac.in/1053/>
6. Dynalog PCL-207 User's manual; June 1996.
7. ATMEL AT89C51 data sheet: [http://www.datasheet4u.com/html/A/T/8/AT89C51-12JC\\_ATMELCorporation.pdf.html](http://www.datasheet4u.com/html/A/T/8/AT89C51-12JC_ATMELCorporation.pdf.html)
8. <http://www.8051projects.net/adc-interfacing/adc0804-interfacing.php>
9. National Semiconductor ADC 0804 Datasheet:  
[http://www.datasheetcatalog.com/datasheets\\_pdf/A/D/C/0/ADC0804.shtml](http://www.datasheetcatalog.com/datasheets_pdf/A/D/C/0/ADC0804.shtml)
10. Mazidi Muhammad Ali ,Janice Gillispie Mazidi , McKinlay Rolin D.- The 8051 Microcontroller and Embedded System Using Assembly and C. Pearson Education,2009