

MATEC Web of Conferences **37**, 01056 (2015)

DOI: 10.1051/mateconf/20153701056

© Owned by the authors, published by EDP Sciences, 2015

BIOMASS CONVERSION INTO SOLID COMPOSITE FUEL FOR BED-COMBUSTION

Roman B. Tabakaev¹, Alexander V. Astafev¹, Alexander V. Kazakov^{1a}, Alexander S. Zavorin¹

¹National Research Tomsk Polytechnic University, 634050 Tomsk, Russia

Abstract. The purpose of this research is the conversion of different types of biomass into solid composite fuel. The subject of research is the heat conversion of biomass into solid composite fuel. The research object is the biomass of the Tomsk region (Russia): peat, waste wood, lake sapropel. Physical experiment of biomass conversion is used as method of research. The new experimental unit for thermal conversion of biomass into carbon residue, fuel gas and pyrolysis condensate is described. As a result of research such parameters are obtained: thermotechnical biomass characteristics, material balances and product characteristics of the heat-technology conversion. Different methods of obtaining solid composite fuel from the products of thermal technologies are considered. As a result, it is established: heat-technology provides efficient conversion of the wood chips and peat; conversion of the lake sapropel is inefficient since the solid composite fuel has the high ash content and net calorific value.

1 Introduction

Currently there is a trend of intensive development of energy from renewable resources: national programs of biological resources involvement in the energetics are adopted more than in 73 countries [1]. The Government of the Russian Federation developed the Federal Law “On Electric Power Industry” and “Energy Strategy of Russia until 2030”, whereby before 2020 power plants on renewable energy sources should produce 20 GW.

Climatic conditions of the Russian Federation do not allow considering solar and winding energy as a substitute for traditional thermal power generation, but a number of experts support the idea of the biomass utilization for energy purposes [1, 2]. Biomass power plants expedient to use in areas with decentralized energy supply, energy which is based on stand-alone diesel power plants or boilers using expensive imported fuel. Distribution of biomass as a fuel is limited by low thermotechnical characteristics (high humidity and ash contamination, small low heat value) and several other reasons: the fragility and small fractional composition leads to sink of the fuel at grate firing, high humidity complicates unloading and transportation in the winter season, etc. Presently biomass burning in modern boiler equipment is an ineffective. Therefore, development of methods for the biomass conversion into solid composite fuel is an actual scientific and technical challenge.

2 The heat-technology of biomass conversion into solid composite fuel

The main disadvantage of most biomass composite fuels [3–6] is the high cost due to the use of expensive and energy-consuming press equipment in the production. Decrease of force is needed for the briquette molding make possible replacement of the press by less energy-intensive and cheaper

^a Corresponding author : kazakov@tpu.ru

screw equipment. Thereby, cost of briquettes will reduce as well. Based on these considerations, the heat-technology of biomass conversion into solid composite fuel was developed by Tomsk Polytechnic University [7–10].

The basis of the heat-technology is low-temperature biomass pyrolysis, wherein the feedstock is converted by the thermal destruction at the charcoal. The heat-technology of biomass conversion is carried out in three stages: thermal recycling of feedstock, forming and drying the composite fuel. At the first stage, the biomass is recycled at a temperature 250–400 °C, resulting in charcoal, pyrolysis condensate and combustible gas are obtained.

In the next step, the binder was prepared by mixing the pyrolysis condensate and dextrin. The ratio of pyrolysis condensate and dextrin is 10:1 [7]. The composite fuel is prepared by adding a binder to the milled charcoal. The final stage is the composite fuel drying at a temperature of 20–80 °C. Within a few days the composite fuel is completely solidified at a temperature of 20 °C.

3 Type and characteristics of biomass

The following types of the Tomsk region biomass were investigated (Fig. 1): the Kandinsky peat, waste wood, Karasevskoye lake sapropel.



Figure 1. Biomass of the Tomsk region (Russian Federation): a) peat of the Kandinsky deposit; b) waste wood; c) lake sapropel of the Karasevskoye deposit

The Kandinsky peat deposit was developed in 1976 by milling mining of up to 400 thousand tons per year. Currently, gravel and clay is being extracted on the peat deposit, which are located under a layer of peat [11–15]. In a natural state the peat has a brown color, high values of moisture and yield volatile, a low ash content and relatively high calorific value (Table 1).

Samples of lake sapropel were taken from the “Karasevo” deposits near the Chazhemto village of Kolpashevsky district. The lake sapropel is a viscous mass with high humidity and ash content, small low heat value. The yield volatile of lake sapropel has a high value (85 %).

As the waste wood was considered wood chips of different woods species (pine, birch, aspen).

Table 1. Thermotechnical characteristics of the Tomsk biomass

Thermotechnical characteristics	Peat	Sapropel	Wood chips
Humidity W_i^r , %	72.8±0.4	67.0±0.4	45.0±0.4
Ash on dry basis A^d , %	9.1±0.2	38.4±0.8	0.6±0.2
Yield volatile V^{daf} , %	71.6±2.1	84.8±2.4	91.8±2.6
Low heat value Q_i^r , MJ/kg	3.1±0.2	2.1±0.2	9.3±0.2

4 The methodology and results of experiments

According to the experimental results, the following conclusions can be made.

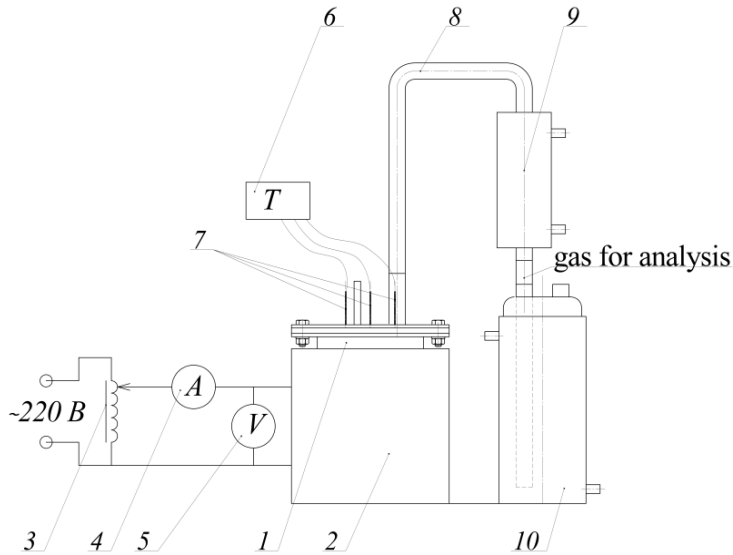

Figure 2. The laboratory unit for biomass conversion: 1 – reactor, 2 – heating element, 3 – autotransformer, 4 – ammeter, 5 – voltmeter, 6 – thermometer, 7 – thermocouples, 8 – hose, 9 – refrigerator, 10 – condenser

Table 2. The material balance of biomass conversion

Conversion products	Mass yield of, %		
	<i>peat</i>	<i>sapropel</i>	<i>wood chips</i>
charcoal	43.4±0.5	67.4±1.8	31.1±3.3
pyrolysis condensate	26.2±2.4	14.1±3.1	23.6±4.4
gas	30.4±2.9	18.5±4.3	45.3±3.0

The composition of gas was determined by chromatograph «Chromatec-Crystal 5000.2». Averaged values of gas composition and its calorific value are shown in Table 3 for a temperature of 200-450 °C.

Table 3. Averaged values of gas characteristics (200-450 °C)

Biomass	Gas composition, %					Heat value, MJ/m ³
	<i>H₂</i>	<i>CO</i>	<i>CH₄</i>	<i>C_mH_n</i>	<i>CO₂+N₂</i>	
peat	23.81	9.80	12.93	12.79	40.68	17.55
sapropel	26.84	7.60	10.21	12.83	42.52	16.65
woodchips	6.46	25.99	19.26	11.48	36.81	19.06

In the wood chips conversion 45 % of its original mass is converted into combustible gas and 55 % can be used for producing a solid composite fuel. In this connection, wood chips can be seen as a raw material for the production of combustible gas and solid composite fuel.

The next stage of obtaining a solid composite fuel is forming. Dextrin is dissolved in the pyrolysis condensate which is preheated to a temperature of (50-70) °C. According to [7] ratio of pyrolysis condensate and dextrin is 10:1. The solution of dextrin and pyrolysis condensate is mixed with charcoal. After composite fuel is formed from a composite of this mixture. This composite fuel solidifies within a few days at 20 °C (Table 4).

Table 4. Thermotechnical characteristics of the solid composite fuel

Thermotechnical characteristics	Solid composite fuel from		
	<i>peat</i>	<i>sapropel</i>	<i>wood chips</i>
Humidity W_i^r , %	~ 0.0	~ 0.0	~ 0.0
Ash on dry basis A^d , %	19.1±0.4	47.1±1.0	2.9±0.1
Yield volatile V^{daf} , %	19.4±0.2	16.5±0.2	13.1±0.2
Low heat value Q_i^r , MJ/kg	21.1±0.2	11.6±0.2	29.4±0.2

The solid composite fuel from wood chips has the highest low heat value, which is comparable with low heat value of anthracite. The thermotechnical characteristics of the composite fuel are superior characteristics of most coals ($W_i^r = 6.0\text{-}24.0\%$, $A^r = 10.2\text{-}39.5\%$, $Q_i^r = 14.4\text{-}25.3$ MJ/kg) that are mined in the territory of the Russian Federation. The composite fuel from peat and wood chips can occupy a large part of the market of solid fuel in remote settlements and towns.

The composite fuel from sapropel has high ash content and low heat value therefore burning of this fuel requires high operating costs.

5 Tests for strength and moisture resistance

Tests of the solid composite fuel on the mechanical strength were conducted in accordance with GOST 21289-75 «Coal briquettes. Methods for the determination of mechanical strength» (Russian Federation): fuel is weighed, dumped onto the metal plate from a height of 1.5 m, collected, sieved and weighed again. The requirements for the test results are given in GOST R 54248-2010 «Briquettes and pellets (pellets) of peat for domestic needs. Specifications»: value of mechanical strength by dropping must be at least 95 %. As a result, all test samples of the composite fuel showed 100 % of resistance to fracture.

In addition, the solid composite fuel was tested by pressing (GOST 21289-75). Maximum compression pressure of the solid composite fuel is 0.18 MPa.

The solid composite fuel was destroyed when tested on moisture resistance (GOST 21290-75 «Coal briquettes. Method for determination of water absorption»).

6 Conclusion

According to the experimental results, the following conclusions can be made.

- Thermal technology of the biomass conversion into solid composite fuel was developed.
- Samples of Tomsk region biomass were converted according to the developed thermal technology. This technology allows efficient conversion of the wood chips and peat (low heat value of solid composite fuel is 21.1-29.4 MJ/kg). Conversion of the lake sapropel is inefficient because the high ash content (56.5 %) and small low heat value (11.6 MJ/kg) of the solid composite fuel.
- Mechanical characteristics of the solid composite fuel meet the requirements of GOST R 54248-2010.
- The solid composite fuel has no moisture resistance.

The reported study was partially supported by the Ministry of education and science of The Russian Federation (Government Order No. 13.948.2014/K and Government Order No. 2069).

References

1. O. S. Popel, B. F. Reutov, A. P. Antropov, Thermal engineering, **57**, 909 (2010).
2. V. M. Kislov, S. V. Glazov, N. A. Chervonnaya and etc., Solid fuel chemistry, **42**, 135 (2008) .
3. S. Perederiy, LesPromInform 72, 162 (2010) [in Russian].
4. B. G. De Oliveira Maia, O. Souza, C. Marangoni, D. Hotza, A. P. N. De Oliveira, N. Sellin, Chemical Engineering Transactions, **37**, 439 (2014).

5. N. S. L. Srivastava, S. L. Narnaware, J. P. Makwana, S. N. Singh, S. Vahora, *Renewable Energy*, **68**, 270 (2014).
6. L. A. Nikolaeva, V. G. Latyshev, O. N. Burenina, *Solid fuel chemistry*, **43**, 109 (2009).
7. R. B. Tabakaev, P. S. Gergelizhiu, A. V. Kazakov, A. S. Zavorin, *IOP Conference Series: Materials Science and Engineering*, **66**, 012052 (2014).
8. A. V. Kazakov, R. B. Tabakaev, P. Y. Novoseltsev, A. V. Astafev, *MATEC Web of Conferences*, **19**, 01014 (2014).
9. A. S. Zavorin, R. B. Tabakaev, P. Y. Novoseltsev, A. V. Astafev, *MATEC Web of Conferences*, **19**, 01015 (2014).
10. P. S. Gergelizhiu, S. A. Khaustov, R. B. Tabakaev, P. Y. Novoseltsev, A. V. Kazakov, A. S. Zavorin, *Proc. of 2014 Int. Conf. on Mechanical Engineering, Automation and Control Systems* (Russia: Tomsk Institute of Electrical and Electronics Engineers Inc., 2014).
11. N. V. Suglobova, T. M. Plakhova, A. V. Kazakov, A. S. Zavorin, *9th Int. Forum on Strategic Technology "IFOST 2014"* (Bangladesh: Cox's Bazar/ Institute of Electrical and Electronics Engineers Inc., 2014).
12. A. V. Kazakov, T. M. Plakhova, R. I. Popov, *MATEC Web of Conferences* **19**, 01019 (2014).
13. A. S. Zavorin, A. V. Kazakov, A.A. Makeev, S.V. Podorov, *Thermal Engineering* **57**, 77 (2010).
14. R. B. Tabakaev, A. V. Kazakov, A. S. Zavorin, *Solid Fuel Chemistry* **49**, 267 (2015).