

EDDY CURRENT THICKNESS MEASUREMENT OF NON-MAGNETIC PRODUCTS. ADVANTAGES AND SOLUTION

Belyankov V.Y., Mylnikova T.S.

Tomsk Polytechnic University

Scientific adviser: Goldshtein A.E., D. Sc., Professor, Department of Information-Measuring Engineering

In order to improve manufacturing quality and ensure public safety, components and structures are commonly inspected for early detection of defects or faults which may reduce their structural integrity. Non-Destructive Testing (NDT) and Evaluation (NDE) techniques present the advantages of leaving the specimens undamaged after the inspection. NDT involves treating defect detection and characterization as inverse problems [1].

Ultrasonic method is universal, and it is mainly used to measure the wall thickness of products. However, it has some drawbacks: the ultrasonic sensor needs the contact with the surface of the object under inspection that requires special surface preparation, and inspection performance. Eddy current method has no disadvantages of this type and can be used to measure the wall thickness of nonmagnetic conductive products. In addition, it can be used to detect defects.

The eddy current probe surface is widely used to solve numerous problems in nondestructive testing: to measure the thickness of conductive objects and non-conductive coatings on a metal base, to control metal and alloy electrical conductivity, to inspect products of different shapes, to perform structuroscopy of nonmagnetic and ferromagnetic alloy parts. The advantages of the eddy current probe surface are their versatility, the ability to control objects of planar, cylindrical and complex shape with one-way access to the inspection object, high resolution and pinpointing the area of the defect when scanning the surface of the inspection object [2, 3]. One of the important inspection problems which can be efficiently solved using the eddy current probe surface is measurement of the wall thickness of nonmagnetic conductive materials and measurement of the thickness of dielectric pipe coating or the air gap between the probe and the pipe surface. A practical example where this probe is used is wall thickness measuring of light-alloy drill pipes made of duralumin D16T. The advantages of these pipes compared to those made of steel are low weight, low flow resistance and non-magnetic properties of the material that are required for directional survey of wells.

Considering this, the eddy current wall thickness gage VT 15.01 was constructed for manual inspection. It provides measurement of the wall thicknesses in the range of (6 ... 15) mm with an accuracy of less than $\pm (0.2$

... 0.5) mm with the gap in the range of (3 ... 12) mm and conductivity of the material deviating from the nominal value by not more than $\pm 10\%$. This gage is the prototype of the final product. It has been created by the development team from the Department of Information Measuring Engineering, Institute of Non-Destructive Testing, TPU. The gage uses the eddy current probe surface optimized to the task of the thickness measuring of light-alloy drill pipes with an external diameter of 147 mm.

The gage allows implementation of the dual-frequency method of detuning from the effect of the change in the gap between the pipe and the eddy-current transducer on the readings of the eddy-current thickness gage for electrically conductive pipes. Excitation of the eddy-current transducer with the signal of the same frequency does not allow extracting information on the gap size. A dual-frequency method is more appropriate for this purpose. Application of these methods and signal processing algorithms for detuning can reduce the error by more than tenfold (from 4.1 mm to 0.2 mm) in case the gap size varies by 5 mm [4].

The wall thickness gage consists of a dual-frequency generator, eddy-current probe surface, amplitude-phase signal processing circuit, data acquisition board, PC and a power supply module. The dual-frequency generator with an output voltage frequency of 125 Hz and 2000 Hz energize the exciting coil (w_1 in Fig. 1) of the eddy current probe surface. The initial electromotive force of the measuring coil (w_{21} and w_{22} in Fig. 1) is compensated, and the added electromotive force U_1 and U_2 is obtained which is transmitted to the two-channel amplitude-phase processing circuit. The reference input of the low-frequency channel is connected to the reference resistor and the high-frequency channel is connected to the compensating coil. The amplitude-phase signal processing circuit forms a quadrature component of the output voltage. The output signals are transmitted to the data acquisition board, which is the USB3000 module, a universal high-speed eight-channel ADC. The module supports the bundled software LabView.

Numerical modeling was used to optimize the probe and study the parameters influencing the eddy current probe signal. Comsol Multiphysics is a powerful simulation environment using the finite element method (FEM) to model and solve different scientific and engineering problems based on partial differential equations (PDEs). FEM accuracy is determined mainly by the mesh density in the computational domain. The drawback of FEM associated with a large amount of computations at high mesh density is considered to be insignificant due to the computing power of modern computers. The mesh density can be enlarged in the areas with small values

of the electromagnetic field gradient parameters and the areas of no computation interest.

Fig. 1 shows the eddy current probe surface over the light-alloy drill pipe in general situation under the influence of some influencing parameters such as wall thickness variation, the gap between the probe and the surface of the pipe y , the electrical conductivity of the material, the curvature of the wall pipe, local thinning of wall pipe, linear x and angular α misalignment of the probe to the pipe, non-uniform wall thickness and the end effect.

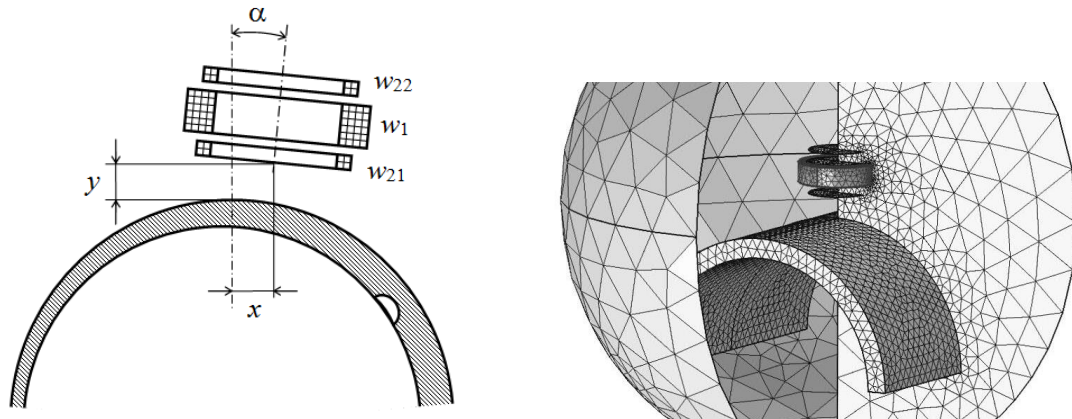

Fig.1. Eddy current probe surface over light-alloy drill pipe and partitioning of the calculation model into finite elements in COMSOL

The experiment was carried out using the eddy current thickness gage VT 15.01. The analysis of the results shows that quantitative discrepancy between the real model and a numerical one within the tested range of the changes in influencing parameters does not exceed 7%. The modeling results are used for signal processing algorithms and detuning to further increase the accuracy of the wall thickness gage.

References

1. M. Buonsanti, F. C. Morabito. Ultrasonic pulse-echoes and eddy current testing for detection, recognition and characterisation of flaws detected in metallic plates. ECNDT 2006 Proceedings - Th.3.3.3, pp. 1-8.
2. Non-destructive testing. Directory / ed. V. V. Klyuyev: 7 volumes. T. 2: a 2 book.: Pr. 1: Check for leakage. Vol. 2: Eddy current testing. M.: Engineering, 2003, p. 688.
3. Shubochkin A.E. Development and current state of the eddy current NDT method: a monograph. M.: Publishing House "Spectrum", 2014, p. 288.
4. Yakimov E.V., Goldstein A.E., Bulgakov V.F., Alkhimov Yu.V., Belyankov V.Yu. Measuring of electroconductive pipe wall thickness using

eddy-current method in presence of large gap between pipe and transducer. Testing. Diagnostocs. №11, November 2014, pp. 14-18.

APPLICATION OF DIGITAL RADIOGRAPHY SYSTEMS FOR OBJECT INSPECTION

Wang Yanzhao

Tomsk Polytechnic University, Tomsk

Scientific adviser: V.A. Udod, D.Sc., professor, TPU

Linguistic adviser: T.S. Mylnikova, Senior Teacher, TPU

The term "digital radiography" refers to a set of methods of nondestructive testing and diagnostics, in which the radiation image of the inspected object is converted at a certain stage in a digital signal. Next, this digital signal is stored in the computer's memory and there it is redistributed in the two-dimensional array of measured data that can be subjected to various types of digital processing (contrast calibration, preparation, smoothing, etc.) and finally, it is displayed on a graphic display screen or a TV-monitor as a grayscale image perceived directly by the operator [1].

Digital radiography is widely used in the leading technologically developed countries due to its obvious advantages over conventional X-ray film radiography, as the constant improvement of the technical parameters of the recording equipment provides information in real time sensitivity without conceding recording on a film. Publications on this topic are focused on the analysis of the characteristics of the used assemblies, sensitivity, performance and resolution [2,3].

The main efforts of scientists and manufacturers are aimed at creating high-performance sources and detectors of ionizing radiation, and computer processing of the results to improve the information content of the control, detection of unauthorized inclusions, finding their location, challenging the dangers of the controlled object [4].

On the basis of two 9 MeV betatron inspection systems an image of the internal contents of the car can be made (Fig. 1)/