

turbine would produce if the steam were shut off. This was important information because the emergency core cooling system required energy for its operation and the coasting turbine could provide some of that energy until another source became available. But the test was delayed because of a demand for electricity, and a new shift of workers came on duty. The operators failed to program the computer to maintain power at 700 megawatts, and output dropped to 30 megawatts. This presented an immediate need to rapidly increase the power, and many of the control rods were withdrawn. Meanwhile, an inert gas (xenon) had accumulated on the fuel rods. The gas absorbed the neutrons and slowed the rate of power increase.

*Decommissioning Costs* – Decommissioning a fossil fuel plant is relatively easy a wrecking ball is about all that is required. Nuclear power plants are not demolished they are decommissioned. Decommissioning involves removing the fuel, cleaning the surfaces, and permanently preventing people from coming in contact with the contaminated buildings and equipment.

#### REFERENCES

1. Alasdairrr's public profile. – [Электронный ресурс]. – Режим доступа: <http://forbes.com/sites/jamesconca/2012/06/10/energys-deathprint-a-price-always-paid> (дата обращения: 04.09.2014).
2. Dr. MacKay Sustainable Energy without the hot air. Data from studies by the Paul Scherrer Institute including non EU data. P. 168. – [Электронный ресурс]. – Режим доступа: [http://inference.phy.cam.ac.uk/withoutair/c24/page\\_168](http://inference.phy.cam.ac.uk/withoutair/c24/page_168) (дата обращения: 04.09.2014).
3. Markandya A., Wilkinson P. Electricity generation and health // *Lancet*, 2007. – Vol. 370(9591).

### WIRELESS POWER TRANSMISSION

**G. Dankov, G. Nizkodubov**  
*Tomsk Polytechnic University*

Introduction: Researchers have developed several techniques for moving electricity over long distances without wires. Some exist only as theories or prototypes, but others are already in use. This paper provides the techniques used for wireless power transmission.

Wireless Power Transmission System.

William C. Brown, the pioneer in wireless power transmission technology, has designed, developed a unit and demonstrated to show how power can be transferred through free space by microwaves. In the transmission side, the microwave power source generates microwave power and the out-

put power is controlled by electronic control circuits. The wave guide ferrite circulator which protects the microwave source from reflected power is connected with the microwave power source through the Coax – Waveguide Adaptor. The tuner matches the impedance between the transmitting antenna and the microwave source. The attenuated signals will be then separated based on the direction of signal propagation by Directional Coupler. The transmitting antenna radiates the power uniformly through free space to the rectenna.

In the receiving side, a rectenna receives the transmitted power and converts the microwave power into DC power. The impedance matching circuit and filter is provided to setting the output impedance of a signal source equal to the rectifying circuit. The rectifying circuit consists of Schottky barrier diodes converts the received microwave power into DC power.

#### Advantages.

Wireless Power Transmission system would completely eliminates the existing high-tension power transmission line cables, towers and substations between the generating station and consumers. The cost of transmission and distribution become less and the cost of electrical energy for the consumer also would be reduced. The power could be transmitted to the places where the wired transmission is not possible. Loss of transmission is negligible level in the Wireless Power Transmission; therefore, the efficiency of this method is very much higher than the wired transmission.

#### Disadvantages.

The Capital Cost for practical implementation of WPT seems to be very high and the other disadvantage of the concept is interference of microwave with present communication systems.

#### Biological Impacts.

Common beliefs fear the effect of microwave radiation. But the studies in this domain repeatedly proves that the microwave radiation level would be never higher than the dose received while opening the microwave oven door, meaning it is slightly higher than the emissions created by mobile telephones.

Conclusion: To sum up, the concept of Wireless Power Transmission system is presented. The technological developments in Wireless Power Transmission (WPT), the advantages, disadvantages and biological impacts are also discussed. This concept offers greater possibilities for transmitting power with negligible losses and ease of transmission than any invention or discovery heretofore made. We can expect with certitude that in next few years' wonders will be wrought by its applications if all the conditions are favorable.

## REFERENCES

1. Aurangzeb M., Crossley P. A., Gale P. Fault Location on a Transmission Line Using High Frequency travelling waves measured at a single line end in power engineering society, 2000.
2. Benson Th.W. Wireless Transmission of Power now Possible.
3. U.S. Patent 787, 412, "Art of Transmitting Electrical Energy through the Natural Mediums".
4. Dombi J. Basic concepts for a theory of evaluation: The aggregative operator // European Jr. Operation Research, 1982. – Vol. 10. – P. 282–293.
5. IEEE Power Systems Relaying Committee (PSRC) // IEEE Guide for Protective Relay Applications to Transmission Lines, IEEE Std. C37.113. – 1999. P. 31.
6. Khorashadi-Zadeh H., Sanaye-Pasand M. Correction of saturated current transformers secondary current using ANNs, IEEE Trans. Power Delivery, 2006. – 21(1). – P.73–79.

## CURRENT STATUS AND PROSPECTS OF "SOUTH KURIL" ENERGY COMPLEX

**A. Doroshenko, N. Kosmynina**  
*Tomsk Polytechnic University*

"South Kuril" energy complex of diesel power plants (DPP) provides electricity to urban village Kurilsk South, located on a peninsula Kunashir Island (South Kuril Islands) with a population of approximately 6,500 people. Block diagram of the energy complex DES "Southern Kurils," is shown in *Figure 1*.

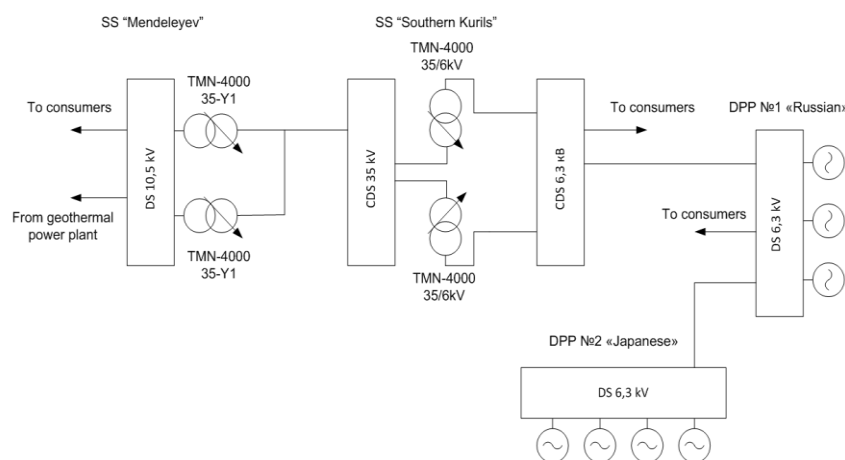

Figure 1. Block diagram of the energy complex "Southern Kuril"