

Real-time comprehensive simulation of electric power systems for the task of overvoltages value determination

N Yu Ruban¹, A S Gusev¹ and V A Sulaymanova¹

¹634050, Tomsk, Russia, National Research Tomsk Polytechnic University

E-mail: rubanny@tpu.ru

Abstract. For a correct determining of the overvoltage limiters characteristics, as well as the optimal location of its installation is required to use reliable information about the primary electrical quantities, especially voltage level, in different operation modes of electric power systems (EPS). This problem is highly complex, due to the danger of the experiments in real EPS. Methods and tools for calculation and researches of quasi-stationary and switching overvoltages which are applied to solve this problem not always allow to obtain satisfactory results. The developed tools of comprehensive real-time simulation of electric power systems, providing adequate reproduction of processes associated with overvoltages in EPS, are presented in the article. Fragments of the researches of switching overvoltage in the electrical network of the real power system are given.

1. Introduction

Reliability and efficiency of design, research and operation of the electric power systems (EPS) depend on the completeness and accuracy of the information about working conditions of the equipment of EPS in normal, emergency and post-emergency modes. In particular, such issues are regulated by guidelines and recommendations for the use of surge arresters in EPS. However, the validity of the choice of types and locations of their installation in accordance with these instructions depends on the adequacy of the information about the possible overvoltage value and duration, the most dangerous of which are switching overvoltage. In view of the known specificity and complexity of modern power systems to obtain this kind of information is possible only by mathematical modeling of EPS. To ensure sufficient completeness and accuracy of the mentioned information mathematical models for all significant power system equipment must be three-phase and comprehensive, continuously and adequately reproduce the real range of operating modes and processes. In this way a model of any real power system, taking into account the allowable partial network reduction contains a very stiff, non-linear high dimensionality system of differential equations. According to the theory of discretization techniques for ordinary differential equations, such systems of equations are poor conditioned on the restrictive conditions of applicability of the numerical integration methods and cannot be solved satisfactorily. The only way to improve the conditioning is to reduce the stiffness of the differential order, nonlinearity and in accordance with Dahlquist's Theorem interval solutions restriction [1]. Necessity of these simplifications and limitations inherent to all software and software-hardware purely numerical EPS simulators and prevents adequate modeling of a single continuous spectrum of quasi-steady-state and transient

¹ N Yu Ruban, rubanny@tpu.ru



processes, including switching surge in EPS with different sorts of normal, emergency and post-emergency conditions of their operation.

2. Hybrid power system simulation

The alternative to the currently used numerical power system simulation [2-5] can be a comprehensive approach, which is hybrid EPS simulation [6-9]. The problem of adequate simulation of large dynamical systems, including EPS, in recent years is discussed in many countries: United States, Europe, China and others. Since 1998 till the present time the annual International Conference on Hybrid Systems: Computation and Control (HSCC) is held.

2.1. Hybrid real-time power system simulator

The concept of continuous, adequate, real-time modeling with an unlimited range of quasi-steady-state and transient processes, including the surge in equipment of EPS, in the case of normal, emergency and post-emergency conditions of their operation was developed to solve problems mentioned above [10, 11]. To implement this concept Hybrid real-time power system simulator (HRTSim) was created [12] and adapted for the researching of all kinds of overvoltage and using this sufficiently complete and accurate information to select the types and locations of surge arresters, including, according to the previously named instructions and recommendations.

2.2. Features of the HRTSim

1. To achieve the necessary completeness and accuracy of the simulation elements of EPS are reproduced by a synthesized for this purpose mathematical models that exclude decomposition of processes in the equipment and the EPS as a whole.

2. The implicit integration method for the continuous, stiff, non-linear systems of differential equations of high dimensionality is used.

3. Formation of simulated three-phase EPS circuit's nodes is at the physical layer by converting the continuous mathematical variable of phase currents of simulated EPS elements to the corresponding physical model currents and voltages. This allows: the almost complete absence of restrictions on the dimension of the simulated power system; adequate representation of the spectrum of all possible three-phase series and shunt switching, including a phase switching; connection of physical models of various equipment and other.

4. Using a digital-to-analog and analog-to-digital conversion of information allows to realize all kinds of automated and automatic control of modeling parameters and settings and obtaining information about operating of relay protection and automation models. Block diagram of the HRTSim is shown in figure 1.

5. Implementation of mentioned above is carried out by developed for this specialized processors (SP), standardized for all kinds of elements EPS and universal for each of them. Each SP includes corresponding physical and mathematical models of power equipment EPS specialized coprocessors (CP) and hybrid microprocessor unit (MPU), consisting of a central processing unit (CPU) and functionally oriented peripheral processors. The three-phase model physical inputs / outputs of all SP equipped with digital-controlled series-shunt switches, which are implemented in the SP. This makes it possible to carry out all kinds of three-phase and per phase switching, including controlled moment of operating.

6. Implementation of mentioned above are based on the latest achievements of IT technologies for potentially necessary range of information and control capabilities for real-time simulation of EPS and effective solutions identified and other problems of design, research and service. For this functional three-phase input / output of A, B, C phases (ABC in figure 1) of the SP are interconnected according to the topology of the simulated power system using a three-phase switch units (TSU), and their CPU of microprocessor units combined through network switches (NS) by local computer network (LCN) with Server, which uses developed for this purpose specialized software.

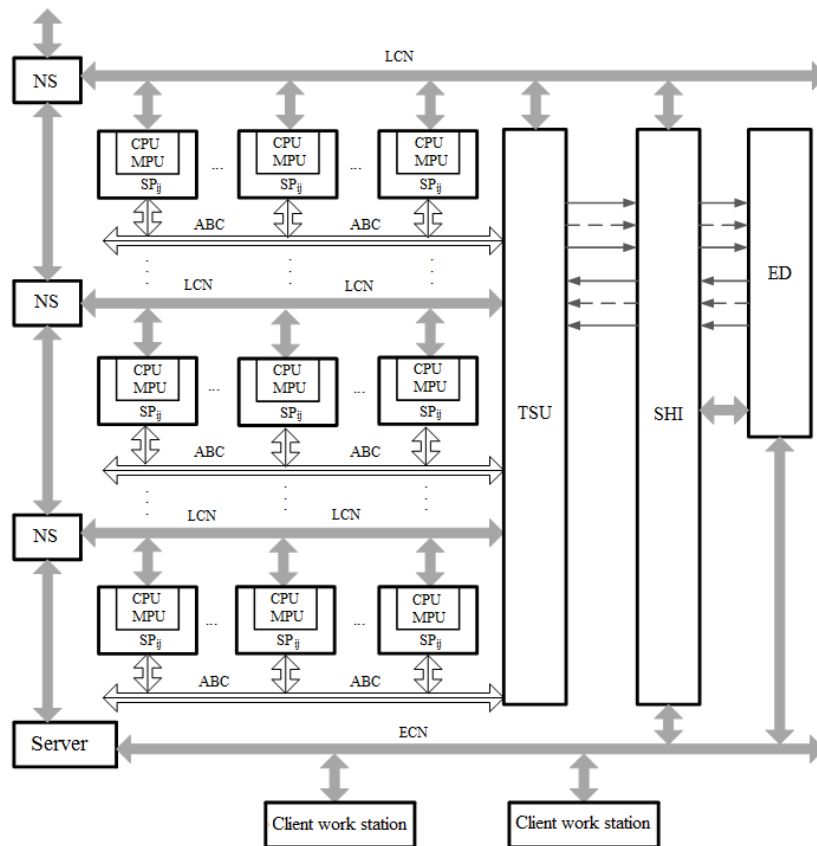

Figure 1. Block diagram of the HRTSim.

7. Professional-oriented software of Client work station is created to use HRTSim. There is no limit to set this software on the server or on users' computers in the external computer networks (ECN), communicating with the server via the Ethernet.

8. For the interaction with real equipment (FACTS control stations, relay protection and automation, SCADA systems, a variety of information management system and other external devices (ED)) are developed appropriate software and hardware interfaces (SHI) that have matching amplifiers for physical interaction with ED and information linkages to the server and SP for the local and external computer networks.

9. For reliable and effective solving of design, research and operation of EPS tasks operational and technical specifications of HRTSim are provided by using of the latest achievements in integrated microelectronics, microprocessor technology and IT.

Developed tools provide continuous and methodically accurate solution in a real time and on an unlimited range with guaranteed acceptable instrumental inaccuracy of stiff, non-linear, high dimensionality systems of differential equations. This allows one to reproduce the spectrum of steady state and transient processes, surges of the real EPS, which in turn makes it possible to produce reliable and valid selection of types and locations of surge arresters installation.

In addition, these features and capabilities of developed simulation tools also provide a reliable solution to the urgent problem of simulated power system model verification, including the specific power equipment, relay protection and emergency automation, various automatic control systems and SCADA systems. Different abilities of HRTSim application with examples of its realization is given in [13-15].

3. Research results

HRTSim reproduces processes in EPS, including overvoltages by continuous and methodically accurate solution of the same comprehensive model of this EPS. Thus, any quasi-steady mode is the current result of the same solution at a frequency close to 50 Hz, and can be reliably verified by the data of operational information complex server of the simulated power system, especially by dispatching measurements. Consequently in the frequency band defined by the gain frequency and phase-frequency characteristics and by microelectronic components used in the submitted tools, also will reproduce significantly all of the processes of this spectrum. Considered verification and identification thoroughly and repeatedly carried out at implementing specific practical researches with HRTSim using for Tyumen, Tomsk EPS and for united power grid of the Far East. As an example, figure 2 shows switching overvoltage oscillograms in the 500 kV network of Tyumen EPS.

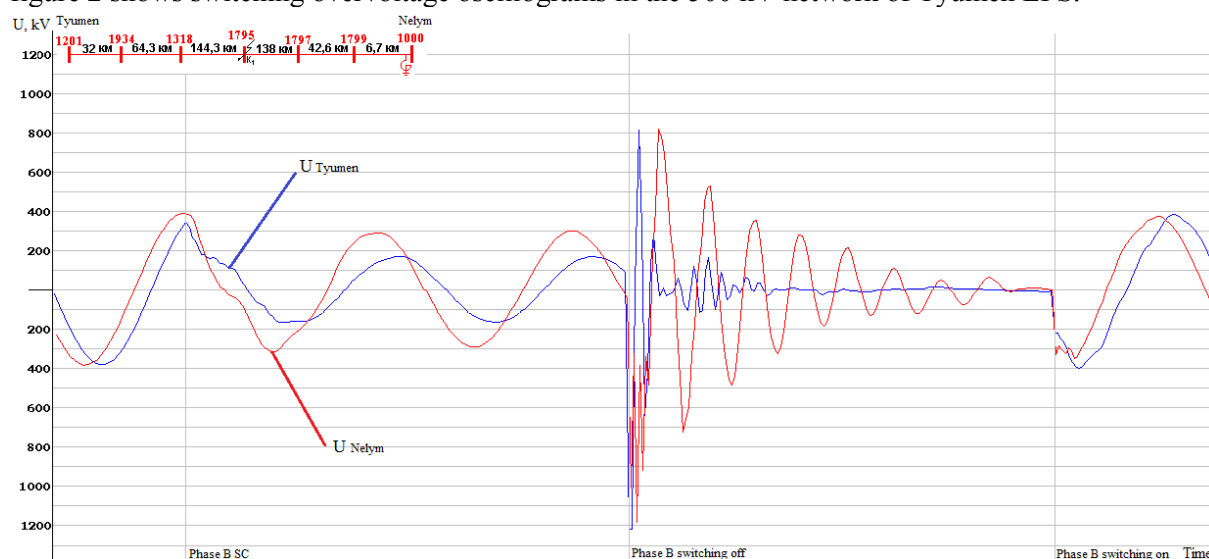

Figure 2. Phase B short-circuit experiment (node 1795) on the 500 kV overhead transmission line Tyumen - Nelym of Tyumen EPS.

These oscillograms display the voltage changes on the buses of Tyumen and Nelym substations of Tyumen EPS over time. In the upper left corner of the figure 2 is presented fragment of the investigated power system scheme, where intermediate nodes and the length of intervals between them are indicated, as well as a fault location is shown here. The experiment as an example of the 500 kV overhead transmission line Tyumen - Nelym of Tyumen EPS includes the following sequence of actions: phase B short circuit (node 1795), switching off the faulted phase and its subsequent switching on.

Switching overvoltages occur after any commutation (planned or emergency) and due to the overcharge of capacities and network parameters changing in the transition process of the system from one state to another. Duration of switching overvoltages can range from a few milliseconds to a few seconds. Switching overvoltages, as well as lightning surges, in most cases higher than acceptable levels of surges for all insulation kinds and therefore should be limited, especially in extra-high voltage electrical installations, which include the 500 kV network. However, the danger of switching overvoltages is determined not only by their large amplitude but also by duration, which is an average of two orders longer than the duration of lightning impulse. Therefore, the switching overvoltage energy is much higher than the energy of lightning surge. As a result the conditions of the equipment operation during the switching overvoltages primarily non-linear resistances of overvoltage limiters is significantly harder because much more power is dissipated in them. The basis for the solution of issues related to the switching overvoltages is initial information about them. It is obvious that the best way of such information obtaining is using of switching overvoltages oscillograms. A set of oscillograms for various power system nodes is a complete map of overvoltages for the region. As a

result of our researches the overvoltage map for 500 kV network of Tyumen EPS was made. This map has helped greatly to solve the task of designing and setting up of protection and automation devices for this region including substantiated selection of types and locations of overvoltage limiters installation, especially nonlinear. Part of the research results was verified according to the dispatching department.

4. Conclusion

Confirmed by results of experimental researches the properties and capabilities of developed comprehensive EPS simulation tools allow to reliably verify and adequately reproduce the entire spectrum of steady-state and transient processes in EPS. This also applies to overvoltage, especially switching overvoltage that forms the most dangerous combination of conditions of the equipment operation according to the values and duration. The use of this sufficiently complete and reliable information about the processes in EPS for all possible normal, emergency and post-emergency conditions of its work provides a reliable and effective solution to most of the important tasks of design, research and service.

Acknowledgments

This work was supported by mega-grant "Hybrid simulation and control of smart grids".

References

- [1] Hall J and Watt M 1976 Modern numerical methods for ordinary differential equations (Oxford: Clarendon Press)
- [2] Feng G, Herrera L, Murawski R, Inoa E, Chih-Lun W, Yi H, Ekici E, Jin W and Beauchamp P 2011 Real time simulation for the study on smart grid *Energy Conversion Congress and Exposition (ECCE)* (Phoenix: IEEE) pp 1013–18
- [3] Li W and Xiao X 2010 Electromagnetic and Electromechanical Transient Hybrid Real-time Simulation Technology Based on RTDS used in Subsynchronous Resonance Research *International Conference on Power System Technology (POWERCON)* (Hangzhou: IEEE) pp 1–6
- [4] Mahseredjian J, Dinavahi V and Martinez J A 2009 Simulation Tools for Electromagnetic Transients in Power Systems: Overview and Challenges *IEEE Trans. Power Delivery*. **24** 1657–69
- [5] Paquin J-N, Belanger J, Snider L A, Pirolli C and Li W 2009 Monte-Carlo study on a large-scale power system model in real-time using eMEGAsim *Energy Conversion Congress and Exposition* (San Jose: IEEE) pp 3194–3202
- [6] Aström K J, Elmqvist H and Mattsson S E 1998 Evolution of Continouostime Modelling and Simulation *Proc. The 12th European Simulation Multiconference* (Manchester: ESM) pp 1–10
- [7] Bond J A, Dorsey J F, Brooke M, Magill J and Tabler J 1994 Fast Solution of Nonlinear Equations Using Parallel Analog Hardware *Analog Integrated Circuits and Signals Processing*. **6** 135–156
- [8] Carullo S P, Olaleye M, Nwankpa C O 2004 VSLI Based Analog Power System Emulator for Fast Contingency Analysis *Proc. Hawaii International System Sciences Conf. (Hawaii: IEEE)* pp 1–8
- [9] Zhang Y, Gole A M, Wu W, Zhang B, Sun H 2013 Development and Analysis of Applicability of a Hybrid Transient Simulation Platform Combining TSA and EMT Elements *IEEE Transaction on power system*. **5(1)** 357–366
- [10] Prokhorov A, Borovikov Yu and Gusev A 2012 Real Time Hybrid Simulation of Electrical Power Systems: Concept, Tools, Field Experience and Smart Grid Challenges *International Journal of Smart Grid and Clean Energy*. pp 67–68

- [11] Borovikov Yu and Sulaymanov A 2013 Information and control system for use in the real time multiprocessor simulation of power equipment *Russian Electrical Engineering* **84** 290–295
- [12] Borovikov Yu S, Prokhorov A V and Andreev M V 2012 Application of Hybrid Real Time Simulator for solution of Smart Grid tasks on the example of Elgaugol energy cluster pilot project *Proc. Int. Conf. IFOST 2012 (Tomsk)* vol 2 (Tomsk: Tomsk Polytechnic University) pp 604–608
- [13] Borovikov Yu S, Sulaymanov A O, Gusev A S and Andreev M V 2014 Simulation of automatic exciting regulators of synchronous generators in hybrid real-time power system simulator *Proc. Int. Conf. Systems and Informatics (ICSAI 2014) (Shanghai)* (Beijing: IEEE) pp 153–158
- [14] Ufa R A, Sulaymanova V A and Gusev A S 2014 Hard- and software of real time simulation tools of Electric Power System for adequate modeling power semiconductors in voltage source convertor based HVDC and FACTS *MATEC Web of Conferences, The 2nd International Youth Forum “Smart Grids”* Volume 19
- [15] Ruban N Yu, Borovikov Yu S and Sulaymanov A O 2014 Simulation of transmission lines phase-comparison protection for optimization its settings *Proc. Int. Conf. IFOST 2014 (Cox's Bazar)* (Bangalore: IEEE) pp 264–267.