

Experimental Investigation of the Contact Angle at Wetting the Non-ferrous Metals

D V Feoktistov, E G Orlova and K O Ponomarev

Thermal Theory and Engineering Department, Tomsk Polytechnic University, Lenin Avenue, 30, 634050, Tomsk, Russia

E-mail: kotyaponomarev@gmail.com

Abstract. Experimental dependences on the effect of the drop volume from the contact angle under the conditions of the static three-phase contact line formation during wetting the non-ferrous metals (aluminium, magnalium, copper and brass) are presented in the work. The surface of the substrates was investigated by modern equipment (profilometer "Micro Measure 3D station" and microscope TM-3000). The drop was placed on the surface by the precision electronic single-channel pipette (Thermo scientific). Shadow method was used to obtain the drop profile; symmetry of the drop was controlled by Schlieren method. The comparison of the methods used to determine the contact angle on the image of the drop profile was executed. It was established that in spite of influencing the friction and gravity forces the structure of metal surfaces affects greatly the value of the contact angle.

1. Introduction

Over the last twenty years heat and mass transfer processes in mini and microsystems [1-5] have attracted attention of many researchers.

It is caused by the intensive development of microelectronics and medicine, as well as the miniaturization of various devices and control of technological processes (aerospace industry, automobile manufacturing, and transportation). There is an intensive development of the micro- and nanosized heat exchange systems. It is found [6] that such systems are much more efficient than their analogues with characteristic dimensions of units and tens of millimeters. For example, in recent years thermosiphons and flat heat pipes with the transverse sizes of 2 millimeters or less are used for microelectronic equipment cooling. However researches in this area are conducted primarily as a search of functional construction versions (it concerns to coolants, materials, regime parameters, sizes, configuration of elements). Such search does not include analyzing the physics of the basic processes occurring in such equipment. Materials for manufacturing the mini-sized heat exchange devices are non-ferrous metals (brass, magnalium, copper, aluminium and others). Studying the physics of the wetting process is possible with using the high-speed video recording and subsequent analysis of frames in order to determine the contact angle.

The purpose of the present work is to determine experimentally the effect of the drop volume on the contact angle under the conditions of the static three-phase contact line formation during wetting the non-ferrous metals.

2. Research technique

Substrates made of aluminium, magnalium, copper and brass were used in experimental research.



Surfaces of substrates were investigated on the profilometer "Micro Measure 3D station" and microscope TM-3000. The parameter of roughness (arithmetic average roughness) and microstructure were defined for substrates under investigation (figures 1-4). The roughness of these substrates is formed by longitudinally arranged grooves.

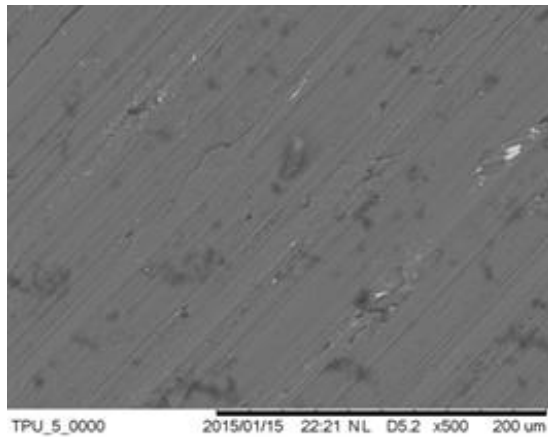

Figure 1. Microstructure of aluminium substrate ($R_a=0.374 \mu\text{m}$).

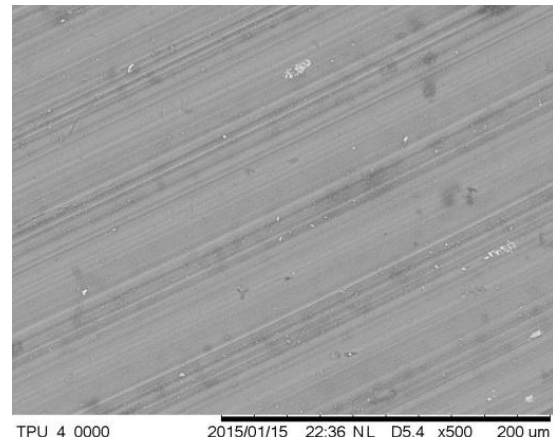

Figure 2. Microstructure of magnesium substrate ($R_a=0.51 \mu\text{m}$).

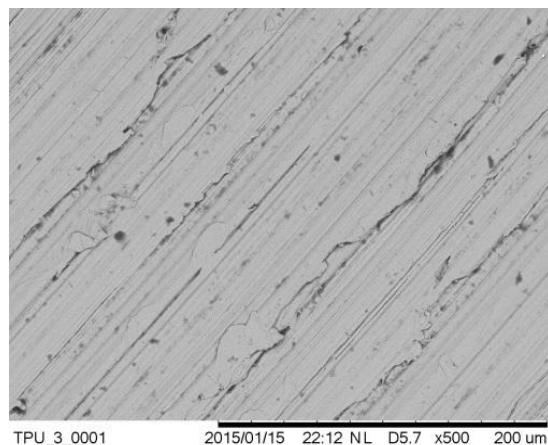

Figure 3. Microstructure of copper substrate ($R_a=0.361 \mu\text{m}$).

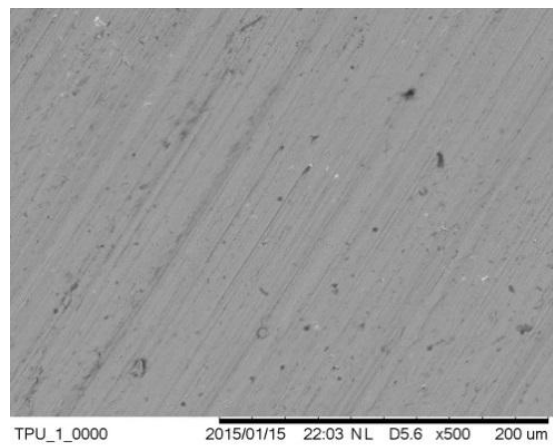

Figure 4. Microstructure of brass substrate ($R_a=0.939 \mu\text{m}$).

The research was conducted by using the experimental setup (figure 5) consisting of the equipment for Shadow and Schlieren methods implementation [7, 8].

Drop with predetermined volume was placed on the surface by the single-channel Thermo Scientific Finnpiptette Novus Electronic pipette. Shadow method was used for obtaining the drop profile. The photographic camera 1 (NIKON D7100) with micro lens (Nikon 105mm f/2.8G IF-ED AF-S) and the light source 2 (MI-150 Edmund) were used for implementation of this method. The contact angle was obtained during image processing in software Drop Shape Analyses (DSA) by two methods (tangential, Young-Laplace). Schlieren method was used to control the drop symmetry.

In shadow optical method the light source 2 with a lens (placed in the widest part of the light source case) are used to produce a beam of plane-parallel light illuminating the drop on the substrate. The distance between the lens and the object under investigation must be greater than or equal to the focal length ($h \geq F$).

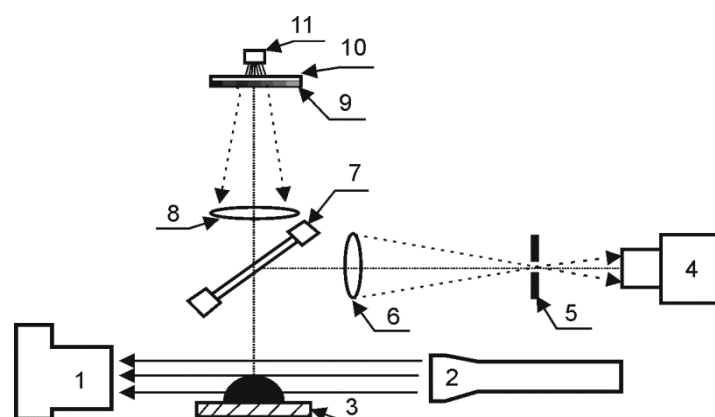

Figure 5. A schematic view of the experimental setup: 1 – photographic camera; 2 – light source of Shadow method; 3 – substrate; 4 – high-speed video camera; 5 – transparent shield with an opening; 6 – lens; 7 – beam splitter; 8 – collimating lens; 9 – coding filter; 10 – ground glass; 11 – light source of Schlieren method.

In Schlieren method the source of incoherent light 11, the ground glass 10 and the coding filter 9 are used for the light flux with a stepped decrease of intensity in space. A beam of light from the source 11 passed through the collimating lens 8, which transformed it into a plane-parallel. Then it was reflected from the beam splitter 7, fell to the substrate and passed to the lens 6 and projected on the sensor of the high-speed video camera 4. The transparent shield with an opening 5 is set for reducing the influence of external light sources .

3. Results and discussion

According to the results of experiments, we obtained the values of contact angle (θ) depending on the drop volumes (V). The experimental data were processed by the least squares method. The maximum value (θ_{\max}) and the corresponding drop volume (V) were determined according to the first derivative of the second order polynomial dependencies. The results are presented in table 1.

Table 1. Results of calculation of the contact angle and the drop volume.

Substrate	Young-Laplace method		Tangential method	
	θ_{\max} (°)	V (μl)	θ_{\max} (°)	V (μl)
Aluminium	86.2	67.4	104.2	78.0
Magnalium	85.5	41.7	85.1	43.4
Copper	85.0	34.3	84.0	35.5
Brass	101.3	35.7	97.9	35.8

The contact angle is plotted over the drop volume for different substrates: brass, magnalium, aluminium, and copper (figure 6).

The maximum divergence of θ_{\max} at obtaining by Young-Laplace and tangential methods was 17% for the aluminium substrate. For magnalium, copper, and brass this value is not more than 4%. Probably, it is due to the most highly reflective surface of the aluminium substrate as compared to other non-ferrous metals, used in the experiments.

According to the classical theory of wetting and spreading, it is known [9] that at increasing the drop volume the contact angle can both increase and decrease. This uncertainty can be explained the following way: at increasing the drop volume the friction force and the weight of the drop impact on

the contact angle. Increase or decrease in the contact angles happens depending on the ratio of these forces and volumes.

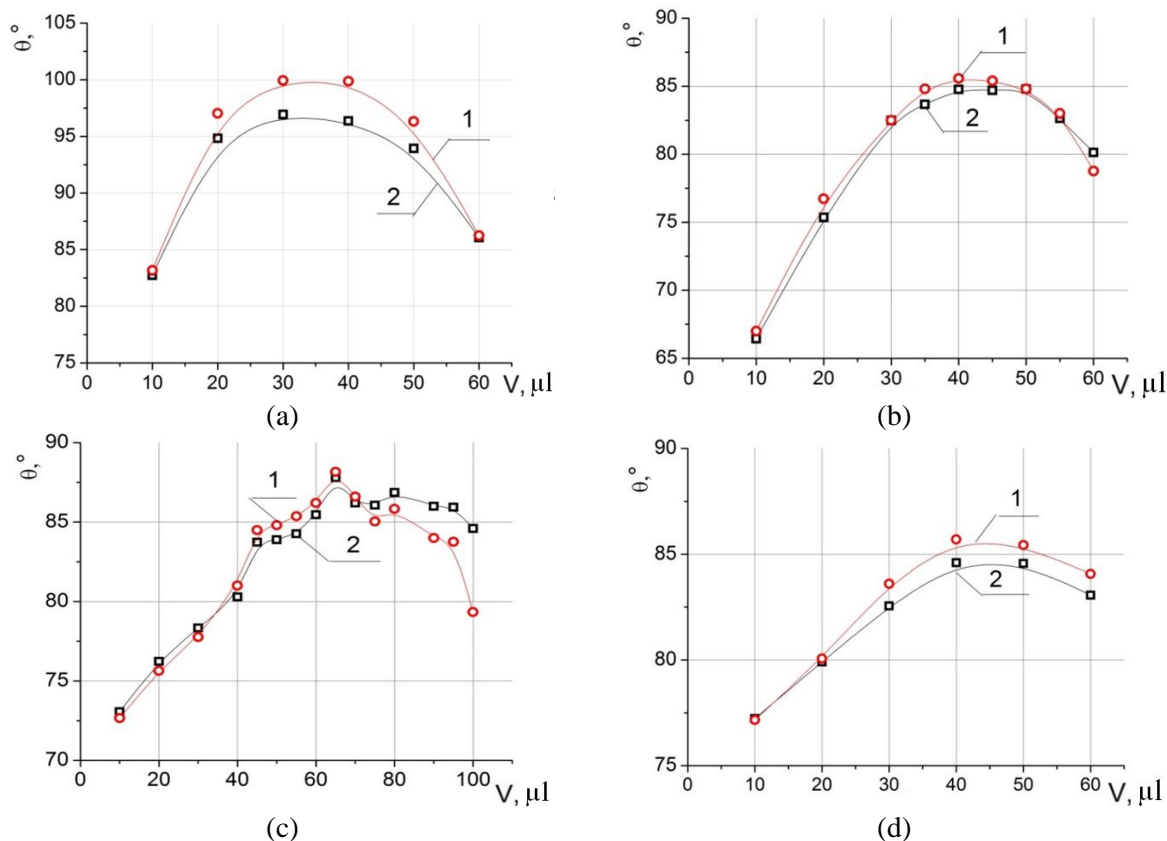

Figure 6. Dependences on the contact angle from the drop volume. Material of the substrate: (a) – brass; (b) – magnalium; (c) – aluminium; (d) – copper. The method of processing the experimental data: 1 - tangential 2 - Young-Laplace.

According to the results of the experiments, it was found that, except the listed forces, material of the substrate affects significantly. The maximum value of θ for each substrate is achieved at different drop volumes (table 1).

It is known [9] that the surface tension at the interface of "liquid-solid" system depends on the nature of the contacting medium and the electric potential.

The dielectric capacitance of the surface of non-ferrous metal is affected by composition and structure. If the surface has a looser structure, so polar molecules can be implemented into such structure (for example, molecules of water or alcohol). It leads to increasing the dielectric capacitance of the surface. In this case, the adhesion between a solid surface and wetting liquid increases. According to the analysis of surface structures of non-ferrous metals used in this experiment (figures 1-4), it was established that the brass and magnalium have a more compact structure. In this case, the implementation in the structure of these metals for the polar liquid molecules is difficult, that affects the large contact angle for the same volume of liquid for the magnalium and aluminium, brass and copper substrates.

4. Conclusion

The influence of the drop volume on the value of the contact angle under the conditions of the static three-phase contact line formation during wetting the non-ferrous metals was defined. A comparison of methods for image processing, allowing to identify the contact angle was executed. The maximum

divergence of θ_{\max} at obtaining by Young-Laplace and tangential methods was 17% for the aluminium substrate. For magnalium, copper and brass this value is not more than 4%. Probably it is due to the most highly reflective surface of the aluminium substrate as compared to other non-ferrous metals, used in the experiments. It was established that, except the friction and gravity forces, the structure of non-ferrous metals influences greatly on the value of the contact angle. The polar molecules (e.g. water or alcohol) can be implemented into the more loose structures of metals. This increases the dielectric capacitance of the surface. As a result, the adhesion between a solid surface and wetting liquid increases. In it turns, it leads to increasing the hydrophobic properties of the surface.

Acknowledgments

Authors thanks to prof. Geniy V. Kuznetsov for his help with analysing the results.

The work was realized within the research state assignment “Science” №13.1339.2014/K (Code of Federal Target Scientific and Technical Program 2.1410.2014).

References

- [1] Misyura S Ya 2014 *Int. Journal Heat Mass Transfer* **71** 197
- [2] Nakoryakov V E, Misyura S Ya and Elistratov S L 2012 *Thermal Science* **16** 997
- [3] Rioboo R, Marengo M and Tropea C 2002 *Exp Fluids* **33** 112
- [4] Gunjal P R, Ranade V V and Chaudharim R V 2005 *AIChE J* **51** 59
- [5] Roques-Carnes T, Mathieu V and Gigante A 2010 *J. Colloid Interface Sci.* **344** 180
- [6] Misyura S Ya, Nakoryakov V E and Elistratov S L 2013 *J Eng Thermophys Rus.* **22** 1
- [7] Orlova E G, Kuznetsov G V and Feoktistov D V 2015 *EPJ Web of Conferences* **82** 01053
- [8] Orlova E G and Kuznetsov G V 2014 *MATEC Web of Conferences* **19** 01006
- [9] Summ B D and Goryunov Yu V 1976 *The Physicochemical Principles of Wetting and Spreading* [in Russian] (Moscow: Khimiya)